

Data sheet

Differential pressure switch / Lube oil protection control

MP 54 and MP 55



MP 54 and MP 55 oil differential pressure switches are used as safety switches to protect refrigeration compressors against low lubricating oil pressure.

If the oil pressure fails, the switch will stop the compressor after a predetermined time period has elapsed.

MP 54 and MP 55 are used in refrigerating systems using HCFC and non-flammable HFC refrigerants.

MP 54 has a fixed differential pressure setting. It also incorporates a thermal time relay with a fixed release time setting.

MP 55 have adjustable differential pressure and are available with thermal time relay.

Features

- Fixed and adjustable differentials available
- Extremely narrow switch differential accuracy
- Reliable, long life stainless steel bellows
- Sturdy metal cover and universal mounting hole patterns
- Integral ½ NPSM swivel cable connector allows direct attachment of ½ in. male pipe thread connector
- Simple manual trip, electrical test function eliminates need of tools and test “jumper” wires
- Standard four-wire hook-up
- Can be used for HCFC and non-flammable HFC refrigerants

Approvals

UL listed for USA and Canada, file E31024

Data sheet | Differential pressure switch / Lube oil protection control, MP 54 and MP 55
Materials in contact with the medium

Unit type	Material
MP 54 MP 55	Stainless steel 19/11, no. 1.4306 to EN 10088 Deep-drawn steel plate, no. 1.0338 to EN 10130 Free cutting steel, no. 1.0718 to EN 10277
MP with capillary tube	Copper Cu-DHP, no. CW024A acc. to EN 12450

Technical data

Ambient temperature	The time relay is temperature-compensated in the range -40 – 140 °F
Switch differential	Maximum 2.8 psi
Maximum working pressure	MWP = 245 psig
Maximum test pressure	P _e = 320 psig
Control voltage	240 or 120 V AC or DC
Permissible voltage variation	-15 – 10%
Contact load of time relay output contacts M-S	240 V AC: 2 FLA
	240 V DC: 0.2 FLA
Electrical connection	NPSM
Max. bellows temperature	212 °F
Cable entry	Integral ½ in. female NPSM swivel cable connector allows direct attachment of ½ in. male pipe thread connector.
Enclosure	~NEMA 1

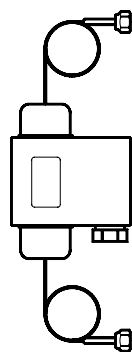
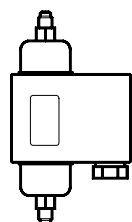
Ordering

For R22, R134a, R404A, R407A, R407C, R407F, R422B, R422D, R448A, R449A, R450A, R452A, R507A, R513A
For complete list of approved refrigerants, visit www.products.danfoss.com and search for individual code numbers, where refrigerants are listed as part of technical data.

Type	Control differential Δp [psi]	Regulation range LP side [inHg] – [psi]	Time relay delay time [s]	Connection Code no.		
				¼ in flare	¼ in flare nut with 36 in capillary tube	¼ in flare nut with 88 in capillary tube
MP 54	6.0	29 inHg – 175 psi	45	060B200866	–	–
	6.0	29 inHg – 175 psi	45	–	060B205066	–
	9.0	29 inHg – 175 psi	90	060B200266	–	–
	9.0	29 inHg – 175 psi	120	060B200366 ²⁾	–	–
	9.0	29 inHg – 175 psi	120	–	060B205366 ²⁾	–
MP 55	4.3 – 65	29 inHg – 175 psi	45	–	060B205466	–
	4.3 – 65	29 inHg – 175 psi	60	060B201266 ¹⁾	–	–
	4.3 – 65	29 inHg – 175 psi	90	060B200666	–	–
	4.3 – 65	29 inHg – 175 psi	120	060B200766	–	–
	4.3 – 65	29 inHg – 175 psi	120	–	060B205766	–

¹⁾ With glow lamp that remains on during normal operation of compressor.

²⁾ Three-wire hook-up

Note:

When time delay is energized which also means that min. permissible oil pressure (differential Δp) is reached, light goes out.

Design

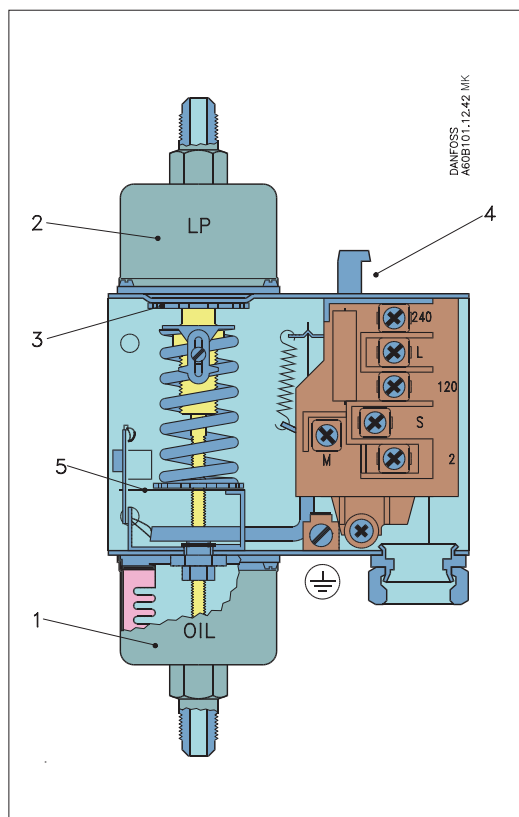

1. Connection to pressure side of lubrication system, OIL
2. Connection to suction side of refrigeration plant, LP
3. Setting disc (MP 55)
4. Reset button
5. Test device

The operation of the pressure switch is based only on the differential pressure, i.e. the difference in pressure between the two counteracting bellows, whereas it is independent of the absolute pressure acting on both bellows.

The MP 55 can be set for different differential pressures by the setting disc (3). The set differential pressure can be read from the internal scale.

The MP 54 has a fixed differential and has no pressure setting disc. The factory-set differential pressure is stamped on the front plate of the switch.

Terminology

Differential range

The pressure difference between LP and OIL connections within which the control can be set to operate.

Scale reading

The differential between the oil pump pressure and the pressure in the crankcase that exists at the moment the contact system cuts in current to the time relay on falling oil pressure.

Operating range

The pressure range on the LP connection within which the switch can operate.

Contact differential

The pressure rise above the set differential pressure (scale reading) necessary to cut off current to the time relay.

Release time

The period for which the differential pressure control allows the compressor to run with too low an oil pressure during start-up and operation.

Electrical diagram

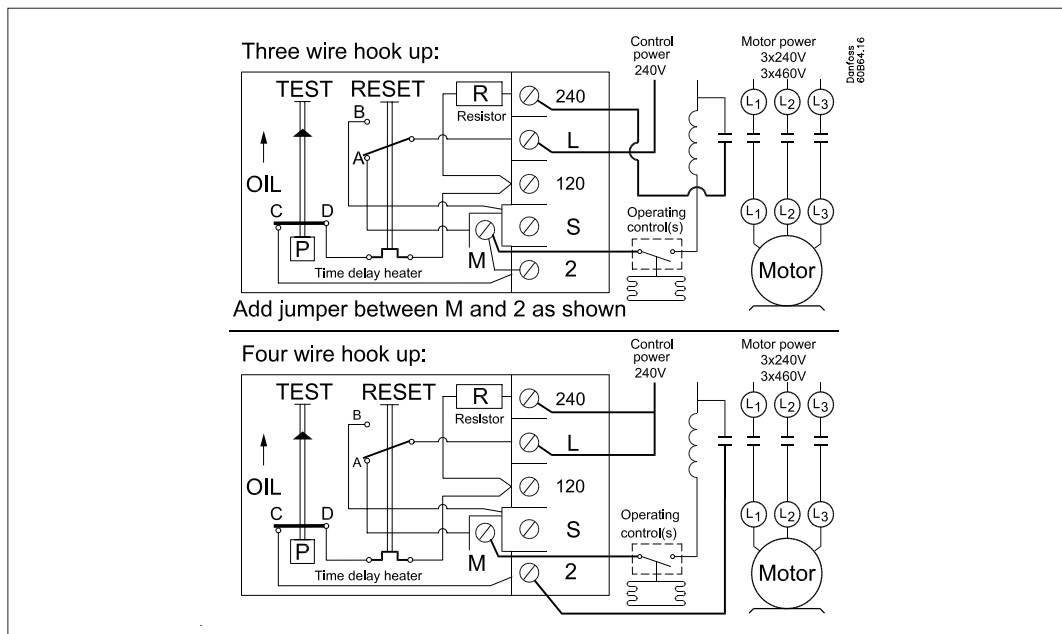

Function

If there is no oil pressure on starting, or if the oil pressure falls below the set pressure during operation, the compressor will stop after the release time has elapsed. The electrical circuit is divided into two completely separate circuits, a safety circuit and an operational circuit.

The timer in the safety circuit is activated when the effective lubricating oil pressure, the oil differential pressure (the difference between the oil pump pressure and suction pressure), is lower than the set value.

The timer is deactivated when the oil differential pressure is more than the set value plus the contact differential.

The two diagrams below explain the terms oil differential pressure" and "contact differential", both have to be considered when using oil differential pressure switches.

The first diagram shows the function of the differential switch during start; the second shows the function of the switch during operation.

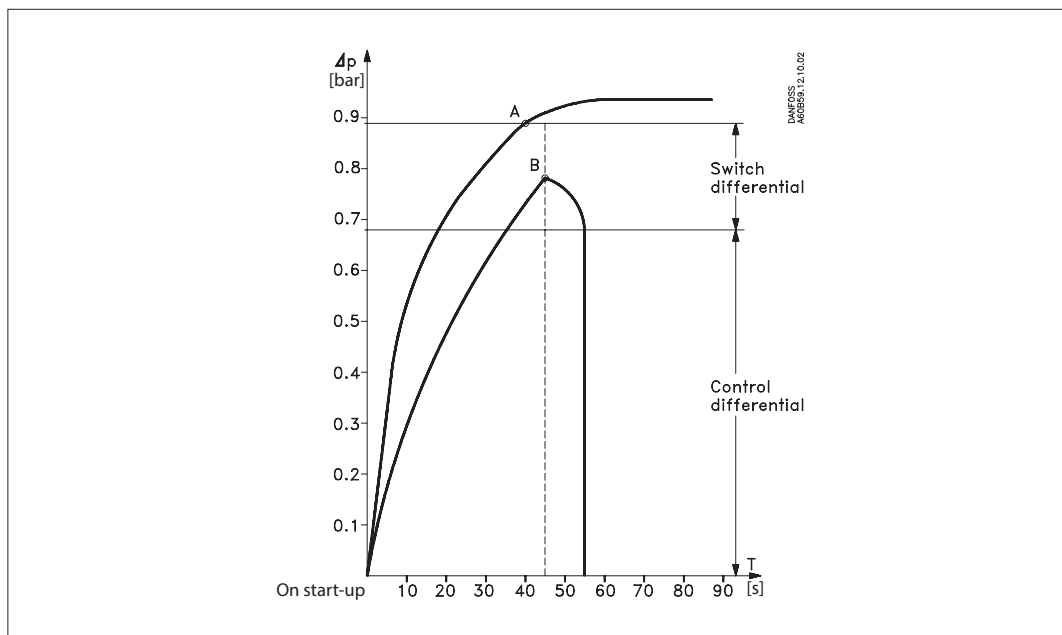

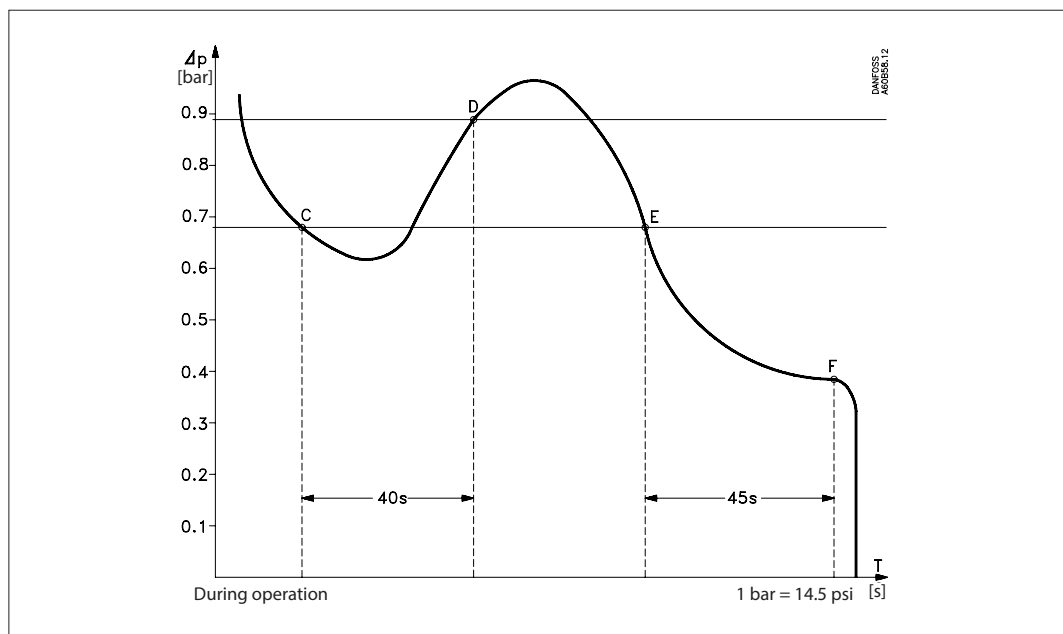

Pos. A:

Normal start-up

The lubricating oil pressure is built up during start to the set/fixed differential plus the contact differential, before the timer cuts out (in this example, after 45 seconds). At point A contacts T1-T2 open and timer (e) is stopped, i.e. normal lubricating oil conditions for the compressor have been established.

Pos. B:

The lubricating oil pressure does not reach the set/fixed differential plus the contact differential before the timer period elapses.

At point B the timer cuts out operational circuit L-M and the compressor stops.

If a signal source is connected to terminal S, it will be activated. Restart can only be performed after about 2 minutes by activation of the reset button, provided the cause of the fault has been determined.

Pos. C:

The lubricating oil pressure falls during operation to a value lower than the set/fixed differential. At point C, safety circuit T1-T2 cuts in and the timer is activated.

Pos. D:

The lubricating oil pressure reaches the set/fixed differential plus the contact differential before the timer period elapses. At point D, safety circuit T1-T2 cuts out and the timer is stopped, i.e. normal lubricating oil conditions for the compressor have been established.

Pos. E:

The lubricating oil pressure falls to a value lower than the set/fixed differential during operation. At point E, safety circuit T1-T2 cuts in and the timer is activated.

Pos. F:

The lubricating oil pressure remains lower than the set/fixed differential. At point F the timer cuts out operational circuit L-M and the compressor stops. If a signal source is connected to terminal S, it will be activated. Restart can only be performed after about 2 minutes by activation of the reset button, provided the cause of the fault has been determined.

After start-up

It is important that a function check should be made to ensure that the differential pressure switch is operating as it should. This check can be made by pressing the test device (inside the unit on the left hand side).

When the test device is pressed down and held in this position the compressor motor should stop after the release time determined by the time relay has elapsed.

**Dimensions [in]
and weights [lb]**

MP 54, MP 55

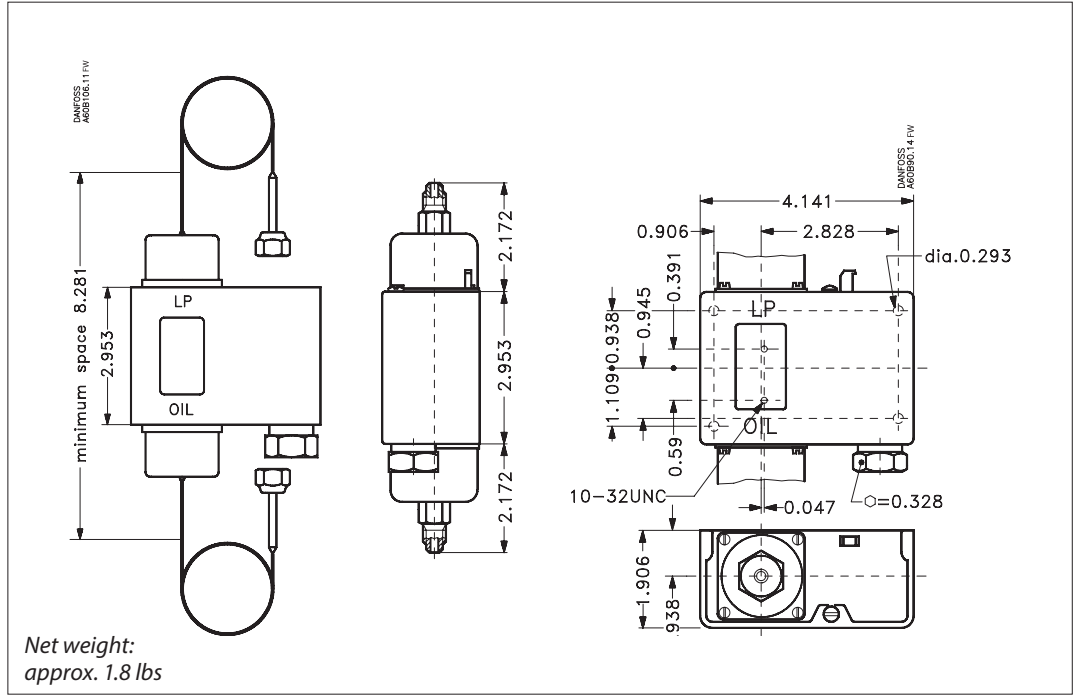

Danfoss can accept no responsibility for possible errors in catalogues, brochures and other printed material. Danfoss reserves the right to alter its products without notice. This also applies to products already on order provided that such alterations can be made without subsequential changes being necessary in specifications already agreed. All trademarks in this material are property of the respective companies. Danfoss and the Danfoss logotype are trademarks of Danfoss A/S. All rights reserved.