

Data sheet

# CI-tronic™ Reversing contactor

## Type RCI



RCI reversing contactors are designed for demanding forward/reverse control of three-phase AC motors. The zero cross switching method ensures very fast and precise motor control and virtually eliminates EMC emission. The RCI reversing contactor is ideal where fast switching capability and long life are essential. Typical applications are conveyors, thread cutting machines, packaging lines and other applications where fast reversing capabilities are needed.

### Features

- Compact modular design complete with heat sink
- DIN-rail mountable
- Built-in varistor protection
- Operational current up to 10 A (AC-3)
- Line voltage up to 480 V AC
- Built-in interlock
- Universal control voltage
- Burst firing (zero cross)
- LED status indicator
- IP 20 protection
- Problem-free specification according to industry standard
- Easy and quick installation
- EN 60947-4-2 and UL-C

**Selection guide**

Operational voltage	Max. motor current	Max. motor power	Control voltages	Dimensions	Type	Code no.
24 – 480 V AC	10 A	4 kW / 5.5 HP	5 – 24 V DC	45 mm module	RCI 10	037N0044
			24 – 230 V AC / DC			037N0043

**Technical data**
**Output specifications**

Operational current AC-3 (motor load) AC 4 (motor load)	10 A 8 A
Motor size at 208 – 240 V AC (50 / 60 Hz)  400 – 480 V AC (50 / 60 Hz)	AC-3: 0.1 – 2.2 kW (0.18 – 3 HP) AC-4: 0.1 – 1.5 kW (0.18 – 2 HP) AC-3: 0.1 – 4 kW (0.18 – 5.5 HP) AC-4: 0.1 – 3 kW (0.18 – 4 HP)
Leakage current max.	1 mA
Operational current min.	10 mA
Semiconductor protection fusing Type 1 coordination Type 2 coordination	50 A gL / gG 450 A <sup>2</sup> s

**Technical data (continued)**
**Thermal specification and environment**

Power dissipation Continuous duty Intermittend duty	2.0 W/A 2.0 W/A x duty cycle
Ambient temperature range	–5 °C to 60 °C
Cooling method	Neutral convection
Mounting	Vertical (± 30°)
Storage temperature range	–20 °C to 80 °C
Enclosure degree / pollution degree	IP 20/3

**Insulation**

Rated insulation voltage, $U_i$	660 V AC
Rated impulse withstand voltage, $U_{imp}$	4 kV
Installation category	III

**Control circuit specifications**

	037N0044	037N0043
Control voltage range (±10%)	5 – 24 V DC	24 – 230 V AC / DC
Pick up voltage max.	4.25 V DC	20.4 V AC / DC
Drop-out voltage min.	1.5 V DC	7.2 V AC / DC
Control current / power max.	25 mA at 4 V DC	6 mA / 1.5 VA at 24 V DC
Response time max.	½ cycle	1 cycle
Interlock delay time (min. / max.)	30 ms / 80 ms	60 ms / 150 ms
EMC immunity	Meets requirements of EN 60947-4-2	

**Functional description**

When control circuit A1 – A2 is ON, the motor will rotate forward. With control circuit A3 – A4 ON the motor will rotate in reverse direction. If both control circuits are switched ON the motor will rotate in the direction determined by the circuit

which was switched ON first. A delay time (interlock) between forward and reverse running is incorporated.

Functional diagram

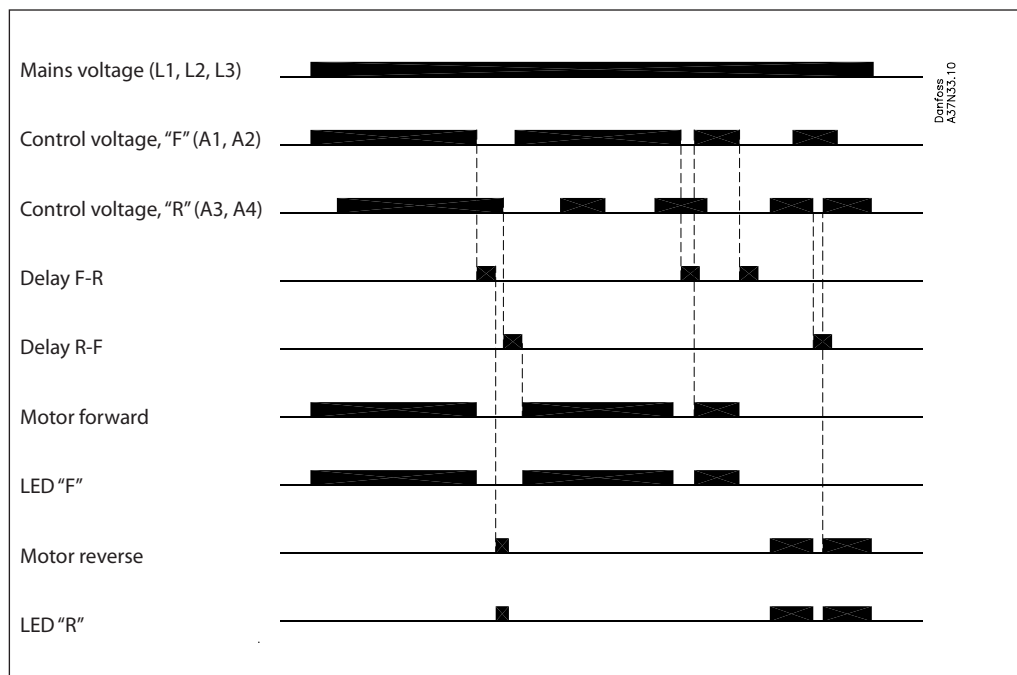

Wiring

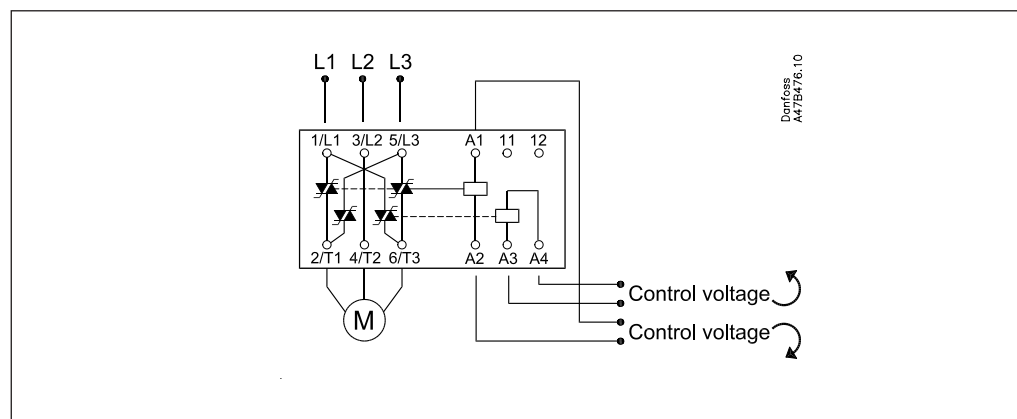

Motor overload and short circuit protection

Motor full load current [A]	Danfoss CTI 25M / CTI 25MB circuit breaker, code no.
0 – 0.16	<b>047B3140</b>
0.16 – 0.25	<b>047B3141</b>
0.25 – 0.4	<b>047B3142</b>
0.4 – 0.63	<b>047B3143</b>
0.63 – 1.0	<b>047B3144</b>
1.0 – 1.6	<b>047B4145</b>
1.6 – 2.5	<b>047B3153</b>
2.5 – 4.0	<b>047B3154</b>
4.0 – 6.3	<b>047B3155</b>
6.0 – 10.0	<b>047B3156</b>

**Dimensions**

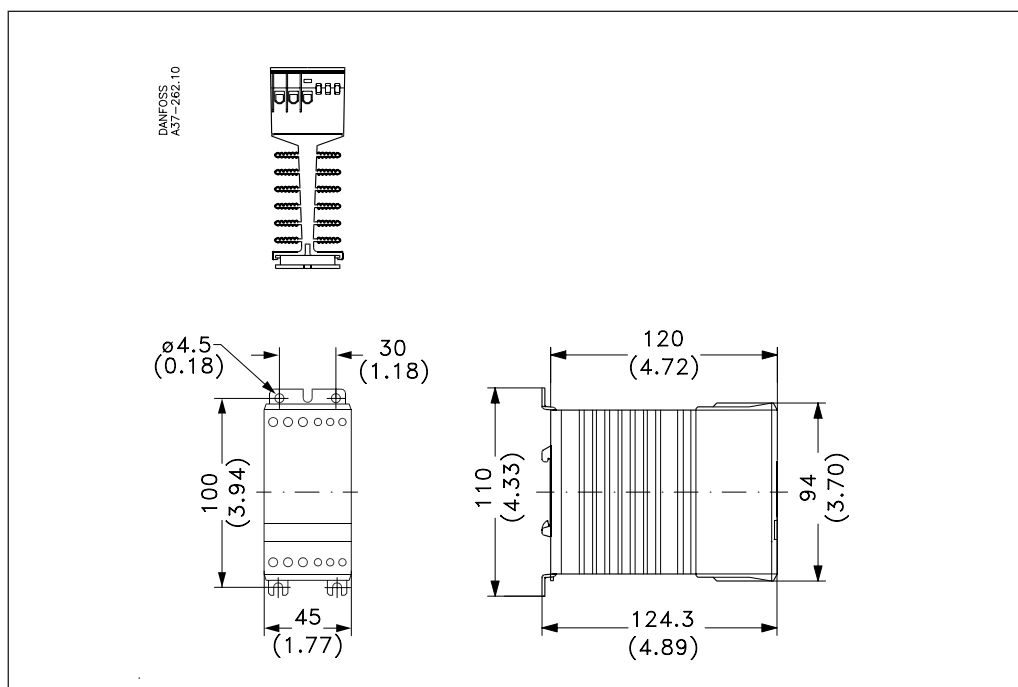

**Mounting**

The controller is designed for vertical mounting. If the controller is mounted horizontally the load current must be reduced by 50%. Controllers mounted side by side need no clearance. Controllers mounted vertically on top of another need a clearance of minimum 80 mm (3.15 in.). Clearance between controller top and "ceiling" and between controller bottom and "floor" must be at least 30 mm (1.2 in.).

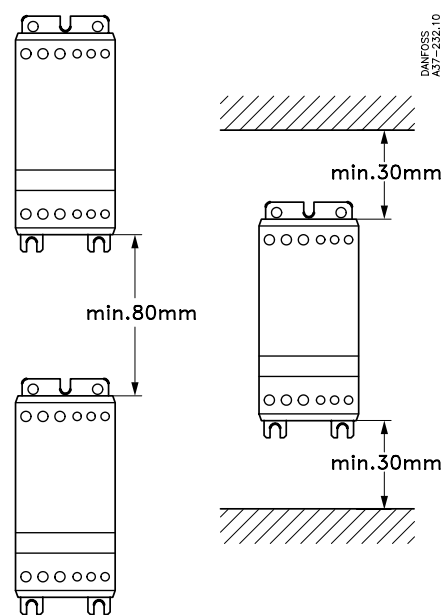

**Overheat protection**

If required the controller can be protected against overheating by inserting a thermostat in the slot on the right-hand side of the controller. Order: UP 62 thermostat 037N0050

The thermostat is connected in series with the control circuit of the main contactor. When the temperature of the heat sink exceeds 100 °C the main contactor will be switched OFF. A manual reset is necessary to restart this circuit. For wiring connections see application examples.

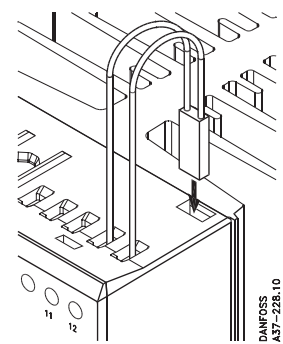

**Application examples**

*Combined reversing contactor and soft starter*

**Soft start & soft stop**

A soft reversing of a motor can easily be achieved by connecting a reversing contactor to the soft starter.

The reversing contactor, type RCI, will determine the direction of rotation, forward or reverse and the soft starter, type MCI, will perform soft starting and soft stopping of a motor.

**Soft start only**

If soft stop is not required, the application can be simplified by connecting the control circuit of the soft starter to the main terminals.

A delay of approx. 0.5 sec. between forward and reverse control signal must be allowed to avoid influence from the voltage generated by the motor during turn-off.

