

Data Sheet

# Steering

## EHi Steering Valve

Danfoss Electrohydraulic In-line Steering Valve (EHi) is intended for off-road use. The EHi is designed for easy integration in new vehicles, as well as upgrading existing vehicles.

EHi with PVED-CLS actuator module form a fail-safe steering valve, category 3 according to ISO 13849-1. EHi fitted with PVED-CLS actuator, as well as a full steering subsystem specification, has a 3rd party certification available.

The EHi is a flexible alternative to Danfoss OSPE, for vehicles where space around the steering unit is particularly limited.

The EHi may be applied for fail-safe Steer-by-Wire applications, joystick or mini wheel for slow moving vehicles. Four-wheel steering, the EHi may be applied for steering the rear axle, for vehicles where fail-safe operation is acceptable.

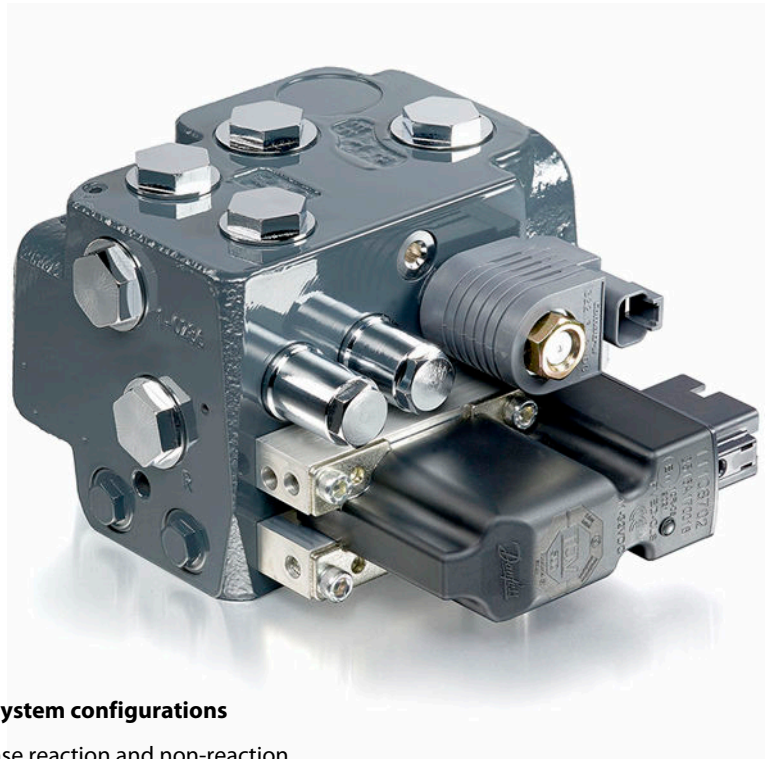

### Features

#### Valve options

- Integrated priority valve, 45 or 90 l/min
- Flow range selections 12, 20, 30, 40, 50 or 70 l/min
- Port thread metric DIN 6149-1

#### Control options

- Full feature steering and safety controller PVED-CLS
  - Auto guidance ISO 11783 – Variable displacement / quick steering
  - Joystick interface – Mini wheel interface
  - Safety functions – PLd / SIL2
  - Hydraulic disengage – CAT 3 fail-safe steering
- CAN bus - flow command PVED-CC
- Analogue ratio-metric PVES

#### Hydraulic system configurations

- Load sense reaction and non-reaction
- Load sense static and dynamic
- Open center reaction and non-reaction
- Closed center

#### Compliance (with PVED-CLS)

- IEC 61508-1(ed.2) (SIL2)
- IEC 61508-2(ed.2) (SIL2)
- IEC 61508-3(ed.2) (SIL2)
- EN 16590-1:2014 (AgPLd, SRL3)
- EN 16590-2:2014 (AgPLd, SRL3)
- EN 16590-3:2014 (AgPLd, SRL3)
- EN 16590-4:2014 (AgPLd, SRL3)
- ISO 13849-1:2008 (up to Cat 3, PLd)
- ISO 13849-2:2012 (up to Cat 3, PLd)

Comprehensive technical literature online  
at [powersolutions.danfoss.com](http://powersolutions.danfoss.com)

**EHi Steering Valve**

**Dimensions**

Outline dimensions in millimeters

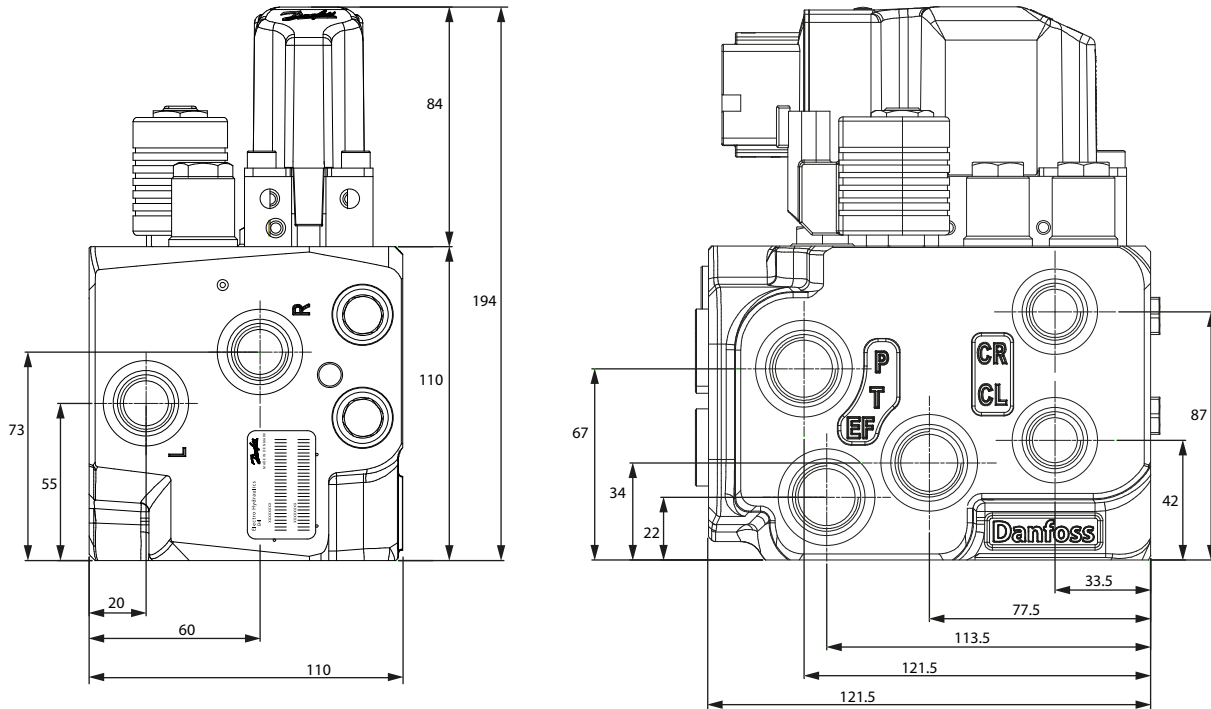

rp1484516161594

**Technical data**

<b>Steering flow</b>	12, 20, 30, 40, 50, 70 l/min
<b>Max. system pressure</b>	210 bar (280 bar)
<b>Max. back pressure (T-port)</b>	25 bar
<b>Priority valve flow</b>	45 and 90 l/min
<b>PVE actuators</b>	PVED-CLS, PVED-CC, PVES
<b>Weight</b>	11.2 kg (24.7 lbs).

Data Sheet  
**EHi Steering Valve**

**EHi for Load Sensing reaction, integrated priority valve**

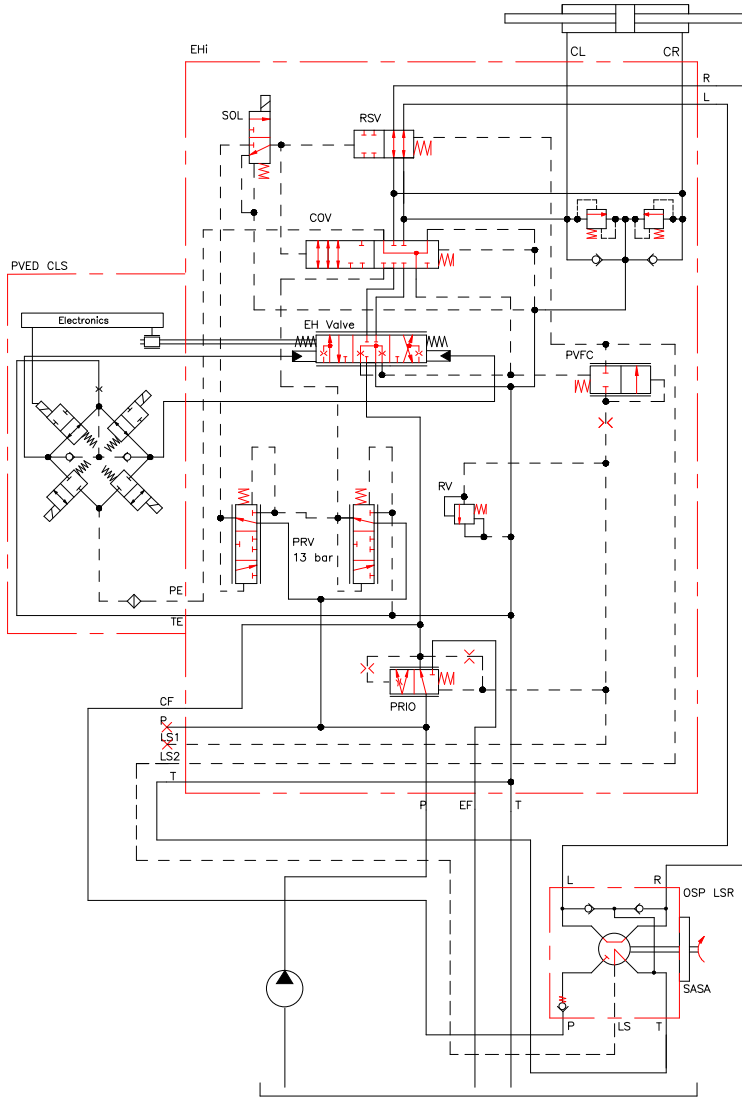

jwr1482444170222

**Applications and Steering devices**

Contact your local Danfoss Power Solutions representative.



**EHi standard configurations**

- OEM installation
- SBW fail-safe
- Rear axle / 4WS
- GPS universal

Configurations	OEM installation						SBW / 4WS	4WS	GPS Universal	
	EHi-1	EHi-2	EHi-3*	EHi-4	EHi-5	EHi-6	EHi-7	EHi-8*	EHi-9*	EHi-10*
<i>Hydraulic Circuit</i>	Load Sensing	Open Center	Closed Center	Load Sensing	Load Sensing	Load Sensing	SBW fail-safe / 4 Wheel Steering	4 Wheel Steering	Load Sensing (Static and Dynamic) With/Without Reaction	Open Center With/Without Reaction
<i>Feature</i>										
EH w. PVES, D CC, CLS	•	•	•	•	•	•	•	•	•	•
Cut-off valve	•	•	•	•	•	•	•	•	•	•
Relief valve	•	•	•	•	•	•	•	•	•	•
Priority valve		•	•	•	•		•	•		•
Shock-suction valves					•	•	•	•	•	•
PVFC LS resolver valve	•			•	•	•			•	•
Reaction Switch Valve for reaction (RSV)					•	•			•	•
OSP override on RSV					•	•			•	•
LS shuttle (SBW or 2WS)								•		
EF and T internally connected				•						
Disengage without SASA (hydraulic disengage)**									•	•
Electrical disengage, for example, by SASA	•	•	•	•	•	•	•	•		

\* Contact Danfoss Power Solutions for information.

\*\* Variable steer mode is not available when using hydraulic disengage.