

Data sheet

Oil Pump type BFP 41 - size 3 and 5

Application

BFP 41 sizes 3 and 5 oil pumps are designed for small/medium-sized domestic oil burners up to 42 l/h.

BFP 41 features:

- Light oil and kerosene
- 1 or 2-pipe operation
- 1-stage
- Built-in pressure regulator
- Solenoid valve cut-off
- Cartridge filter

Function

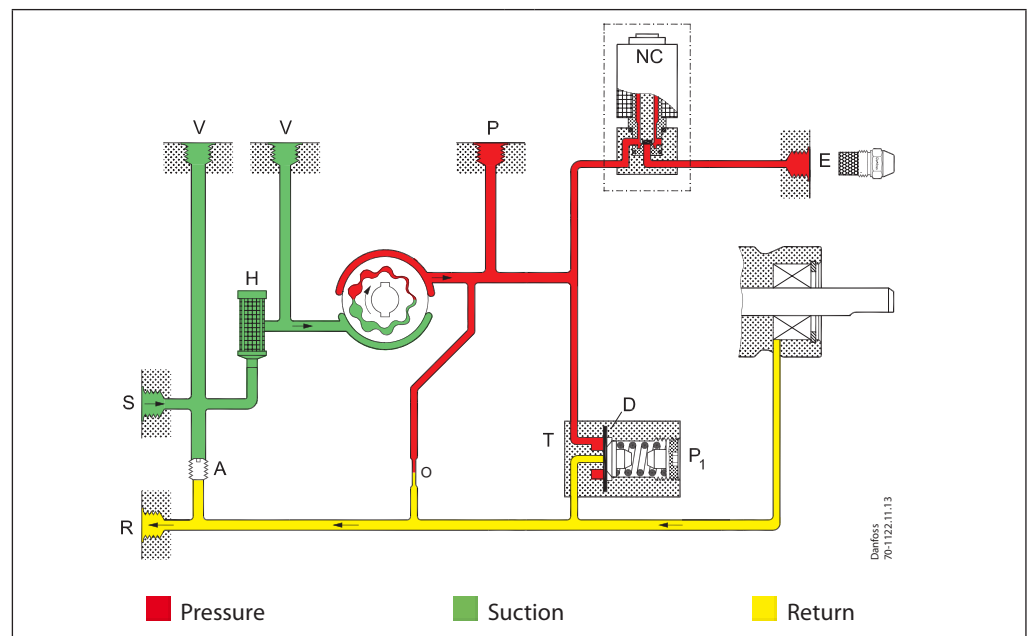

From the suction inlet (S) oil is drawn through the filter (H) to the gear set, where the pressure is increased. When voltage is applied to the NC-valve (normally closed), it opens and releases oil to the nozzle outlet.

By means of the diaphragm (D) in the pressure regulator (T), the pressure is kept constant at the value set on adjustment screw (P_1).

In 2-pipe systems the excess oil is led back to the return outlet (R) and the tank.

In 1-pipe systems with plugged return outlet (R) and screw (A) removed, the oil is returned internally to the gear set (see details in figure).

Cut-off function, solenoid valve

When the burner stops, the voltage to the NC-valve is cut off and the oil flow to the nozzle outlet is cut off immediately.

Bleeding

In 2-pipe systems the pump is self-priming, i.e. bleeding is performed via the constriction (O) to the return outlet (R).

In 1-pipe systems with plugged return outlet (R), bleeding must be performed through the nozzle outlet (E) or the pressure gauge port (P).

Warranty

For pumps used outside the stated technical data and used with oil containing abrasive particles Danfoss cannot give any warranty.

Note!

Do not mount the pump with the solenoid valve pointing downwards.

The solenoid valve must be replaced after 250.000 operations or 10 years (approved life expectancy).

Identification

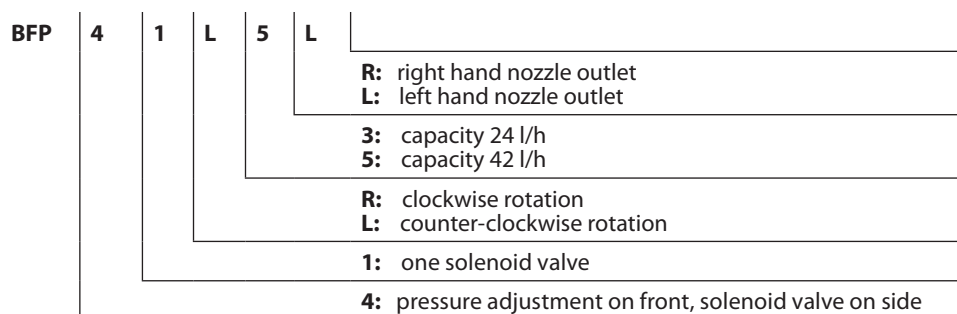

Nozzle capacity at 4.3 cSt., 10 bar, 2800 min⁻¹

Technical data

BFP 41	3	5
Oil types	Standard fuel gas oil and fuel gas oil acc. to DIN V 51603-6 EL A Bio-10 (max. 10% FAME)	
Viscosity range (measured in suction inlet) ¹⁾	(1.3) 1.8 to 12.0 cSt. (mm ² /s)	
Filter area / mesh	11 cm ² /200 μm	
Pressure range ²⁾	7 to 20 bar	
Default setting	10 ± 1 bar	
Max. pressure in suction inlet/return outlet	2 bar	
Speed	2400 to 3450 min ⁻¹	1400 to 3450 min ⁻¹
Max. starting torque	0.1 Nm	0.12 Nm
Ambient/transport temperature	-20 to +70° C	
Temperature of medium	0 to +70° C	
Coil power consumption	9 W	
Rated voltage (other voltages on request)	230 V, 50/60 Hz	
Coil enclosure	IP 40	
Shaft/neck	EN 225	

¹⁾ Special pumps for Kerosene

²⁾ Max. 12 bar at 1.3 cSt., max. 15 bar at 1.8 cSt.

Nozzle capacity

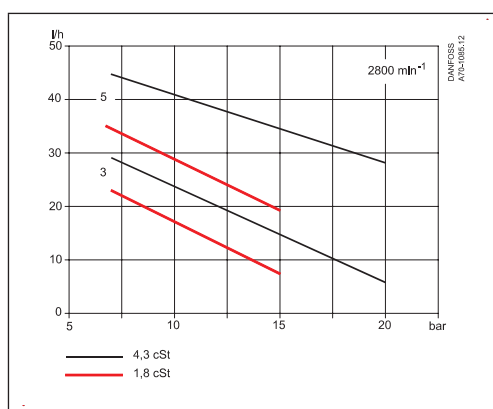

Operating torque

Power consumption

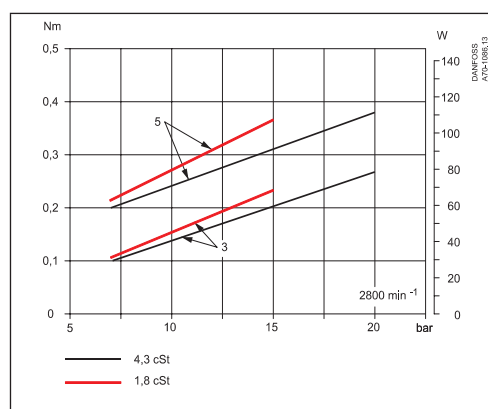

Connections

Example shows BFP 41 L5L

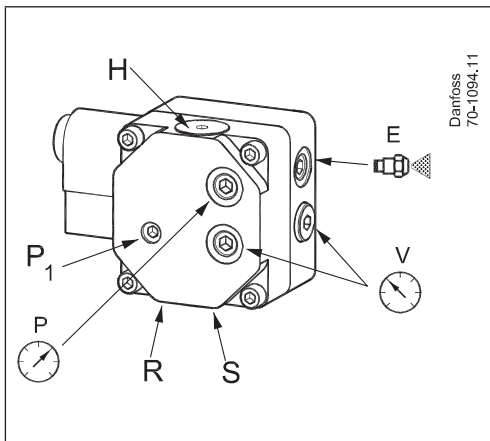

Danfoss
70-1094.11

- P₁:** Pressure adjustment
- S:** Suction inlet G 1/4
- R:** Return outlet G 1/4
- E:** Nozzle outlet G 1/8
- P:** Pressure gauge port G 1/8
- V:** Vacuum gauge port G 1/8
- H:** Filter

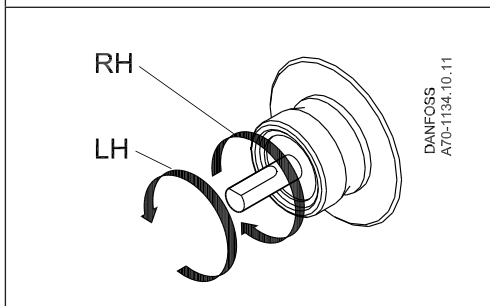

DANFOSS
A70-1134.10.11

Note! Shaft rotation, location of nozzle outlet and other connections are seen from shaft end.

- RH:** R-rotation
- LH:** L-rotation

Change-over and Filter Replacement

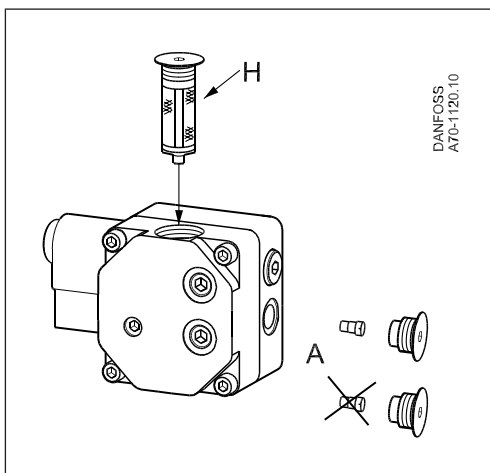

DANFOSS
A70-1120.10

- H:** Filter
- A:** 2-pipe operation, with screw
1-pipe operation, without screw

Dimensions

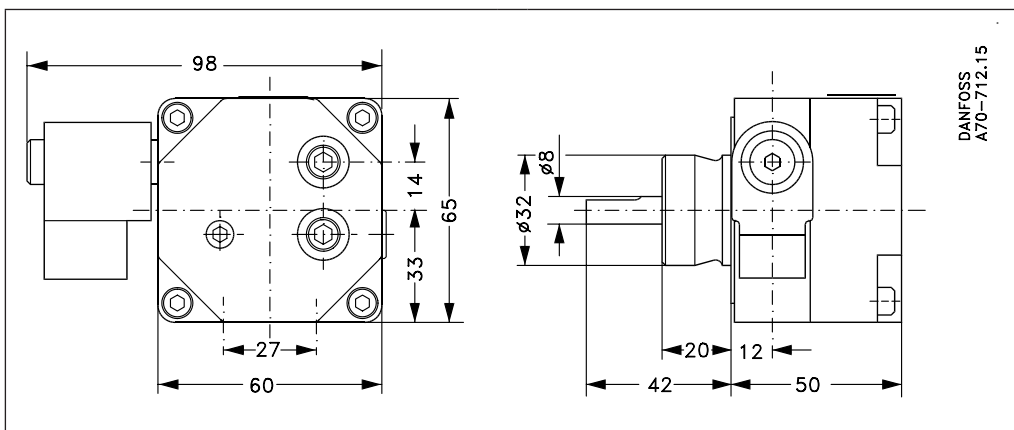

DANFOSS
A70-712.15



Additional documentation on burner components is available on <http://heating.danfoss.com/>

Danfoss A/S

Heating Segment • heating.danfoss.com • +45 7488 2222 • E-Mail: heating@danfoss.com

Danfoss can accept no responsibility for possible errors in catalogues, brochures and other printed material. Danfoss reserves the right to alter its products without notice. This also applies to products already on order provided that such alterations can be made without subsequential changes being necessary in specifications already agreed. All trademarks in this material are property of the respective companies. Danfoss and all Danfoss logotypes are trademarks of Danfoss A/S. All rights reserved.
