

Catalogue

Switches and thermostats for Industrial Refrigeration

Contents

	Page
Thermostat, type KP	3
Pressure switch, KP	15
Thermostat, Differential thermostat, type RT	27
Pressure switch, Differential pressure switch, type RT	43
Differential pressure switch, MP 54, MP 55 and MP 55A	57
Liquid level switch, type AKS 38	65

Thermostat

KP

Contents

	Page
Features	5
Approvals	5
Ship approvals	5
Technical data	6
Contact systems	6
Regulating range	7
Ordering	8
Design / function	10
Terminology	11
Setting	12
Charges	12
Dimensions [mm] and weights [kg]	13

Thermostat KP



The KP Thermostats are single-pole, double-throw (SPDT) temperature-operated electric switches.

They can be connected directly to a single-phase AC motor of up to approx. 2 kW or installed in the control circuit of DC motors and large AC motors.

The KP Thermostats are used for regulation, but can also be seen in safety monitoring systems.

They are available with vapour charge or with adsorption charge. With vapour charge the differential is very small. The KP Thermostats with adsorption charge are widely used to give frost protection.

Features

- Wide regulating range
- Can be used for deep freeze, refrigeration and air conditioning plant
- Welded bellows elements mean increased reliability
- Small dimensions. Easy to install in refrigerated counters or cold rooms
- Ultra-short bounce times. This gives long operating life, reduces wear to a minimum and increases reliability
- Standard versions with changeover switch. Possible to obtain opposite contact function or to connect a signal
- Electrical connection at the front of the unit. Facilitates rack mounting. Saves space
- Suitable for alternating and direct current
- Cable entry of soft thermoplastic for cables from 6 to 14 mm diameter
- Extensive and wide range

Approvals

CE-marked in accordance with EN 60947-4/-5 for sale in Europe

China Compulsory Certificate, CCC
Underwriters Laboratories Inc., US – UL
GOST

Ship approvals

Germanischer Lloyd, GL (excluding KP 98)
Registro Italiano Navale, RINA
Bureau Veritas, France, BV (excluding KP 98)
Lloyd's Register, LR (excluding KP 79, KP 81, KP 98)

Russian Maritime Register of Shipping, RMRS
Note: Marine Approvals do not cover KP 98 dual thermostat.

Thermostat, type KP

Technical data

Ambient temperature		-40 – 65 °C (80 °C for max. 2 hours).
Switch		Single-pole, double-throw (SPDT) changeover switch.
Contact load	Alternating current	AC1 = 16 A, 400 V AC3 = 16 A, 400 V
	Direct current	DC13: 12 W, 220 V control current
Wire dimensions	solid / stranded	0.75 – 2.5 mm ²
	flexible, without ferrules	0.7 – 2.5 mm ²
	flexible, with ferrules	0.5 – 1.5 mm ²
Tightening torque		max. 2 Nm
Rated impulse voltage		4 kV
Pollution degree		3
Short circuit protection, fuse		16 A
Insulation		400 V
Enclosure		30/44

Cable connection

Cable entry for cables 6 – 14 mm dia.
A Pg 13.5 screwed cable entry can be used for 6 – 14 mm dia. cables.
With 8 – 16 mm cables a standard Pg 16 screwed cable entry can be used.

Enclosure

IP30 to EN 60529 / IEC 529
This grade of enclosure is obtained when the unit is mounted on a flat surface or bracket.
The bracket must be fixed so that all unused holes are covered.

Contact systems

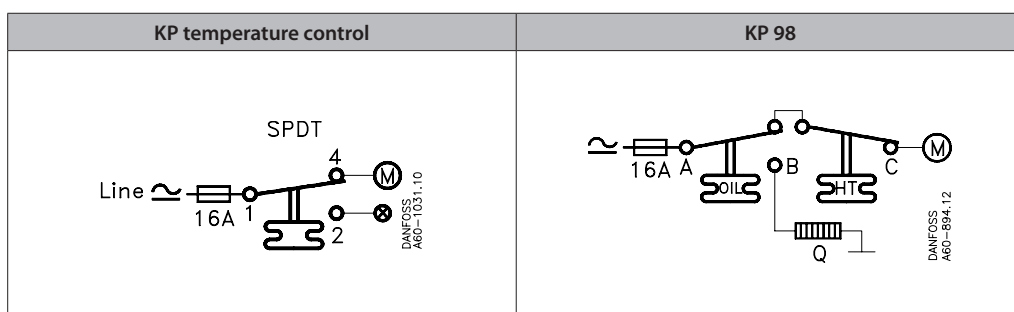

Thermostat, type KP

Regulating range

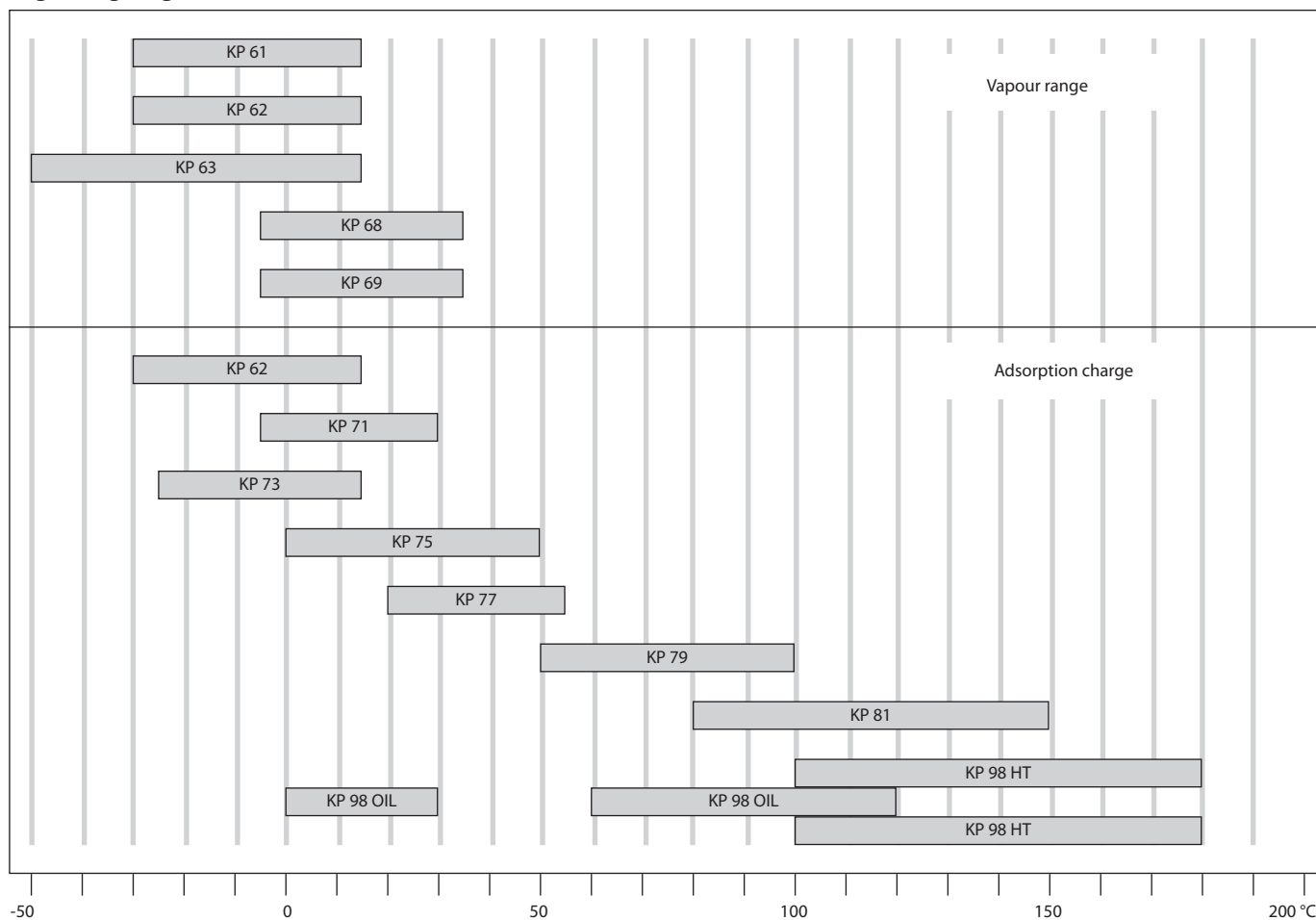

Thermostat, type KP

Ordering

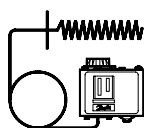
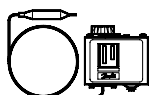

Charge	Type	Bulb type	Setting - range	Differential Δt		Reset	Max. bulb temp.	Capillary-tube length	Code no.
				Lowest temperature	Highest temperature				
				[°C]	[°C]				
Vapour ¹⁾	KP 61	A	-30 – 15	5.5 – 23	1.5 – 7	aut.	120	2	060L110066
	KP 61	A	-30 – 15	5.5 – 23	1.5 – 7	aut.	120	5	060L110166
	KP 61	B	-30 – 13	4.5 – 23	1.2 – 7	aut.	120	2	060L110266
	KP 61	B	-30 – 15	5.5 – 23	1.5 – 7	aut.	120	2	060L110366 ³⁾
	KP 61	B	-30 – 15	5.5 – 23	1.5 – 7	aut.	120	2	060L112866 ^{3) 4)}
	KP 61	A	-30 – 15	Fixed 6	Fixed 2	min.	120	5	060L110466
	KP 61	B	-30 – 15	Fixed 6	Fixed 2	min.	120	2	060L110566
	KP 62	C 1	-30 – 15	6.0 – 23	1.5 – 7	aut.	120	–	060L110666
	KP 63	A	-50 – 10	10.0 – 70	2.7 – 8	aut.	120	2	060L110766
	KP 63	B	-50 – 10	10.0 – 70	2.7 – 8	aut.	120	2	060L110866
	KP 68	C 1	-5 – 35	4.5 – 25	1.8 – 7	aut.	120	–	060L111166
	KP 69	B	-5 – 35	4.5 – 25	1.8 – 7	aut.	120	2	060L111266
Adsorbtion ²⁾	KP 62	C 2	-30 – 15	5.0 – 20	2.0 – 8	aut.	80	–	060L111066 ^{3) 4)}
	KP 71	E 2	-5 – 20	3.0 – 10	2.2 – 9	aut.	80	2	060L111366
	KP 71	E 2	-5 – 20	Fixed 3	Fixed 3	min.	80	2	060L111566
	KP 73	E 1	-25 – 15	12.0 – 70	8.0 – 25	aut.	80	2	060L111766
	KP 73	D 1	-25 – 15	4.0 – 10	3.5 – 9	aut.	80	2	060L111866 ³⁾
	KP 73	D 1	-25 – 15	Fixed 3.5	Fixed 3.5	min.	80	2	060L113866
	KP 73	D 2	-20 – 15	4.0 – 15	2.0 – 13	aut.	55	3	060L114066
	KP 73	D 1	-25 – 15	3.5 – 20	3.25 – 18	aut.	80	2	060L114366
	KP 75	F	0 – 35	3.5 – 16	2.5 – 12	aut.	110	2	060L112066
	KP 75	E 2	0 – 35	3.5 – 16	2.5 – 12	aut.	110	2	060L113766
	KP 77	E 3	20 – 60	3.5 – 10	3.5 – 10	aut.	130	2	060L112166
	KP 77	E 3	20 – 60	3.5 – 10	3.5 – 10	aut.	130	3	060L112266
	KP 77	E 2	20 – 60	3.5 – 10	3.5 – 10	aut.	130	5	060L116866
	KP 79	E 3	50 – 100	5.0 – 15	5.0 – 15	aut.	150	2	060L112666
	KP 81	E 3	80 – 150	7.0 – 20	7.0 – 20	aut.	200	2	060L112566
	KP 81	E 3	80 – 150	Fixed 8	Fixed 8	max.	200	2	060L115566
	KP 98	E 2	OIL: 60 – 120	OIL: Fixed 14	OIL: Fixed 14	max.	150	1	060L113166
E 2		HT: 100 – 180	HT: Fixed 25	HT: Fixed 25	max.	250	2		

¹⁾ Bulb must always be placed colder than the thermostat housing and capillary tube. The thermostat will then regulate independent of ambient temperature.

²⁾ Bulb can be placed warmer or colder than thermostat housing and capillary tube, but variations from 20 °C ambient temperature will influence the scale accuracy.



³⁾ With manual switch, not isolating switch.

⁴⁾ Panel mounting model with top plate.

Thermostat, type KP

Ordering (continued)

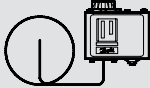
Thermostat bulb types

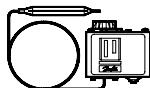
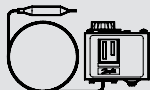
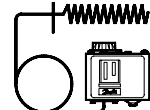
A		Straight capillary tube
B		ø9.5 × 70 mm remote air coil
C		C1: ø40 × 30 mm air coil C2: ø25 × 67 mm air coil (integral with thermostat)
D		D1: ø10 × 85 mm double contact remote bulb D2: ø16 × 170 mm double contact remote bulb Note! Cannot be used in sensor (bulb) pocket
E		E1: ø6.4 × 95 mm remote bulb E2: ø9.5 × 115 mm remote bulb E3: ø9.5 × 85 mm remote bulb
F		ø25 × 125 mm remote duct coil

Thermostat, type KP

Design / function

Key sketch of KP thermostat

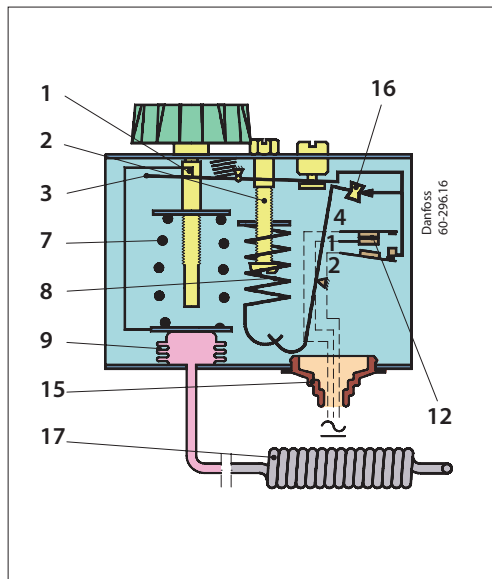

1. Temperature setting spindle
2. Differential setting spindle
3. Main arm
7. Main spring
8. Differential spring
9. Bellows
12. Switch
13. Terminals
14. Earth terminal
15. Cable entry
16. Tumbler
17. Sensor

KP thermostat

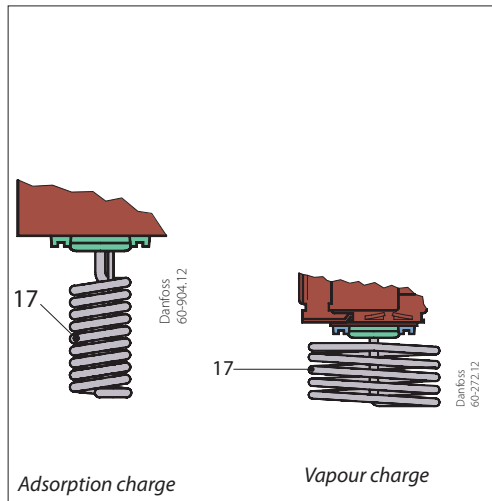
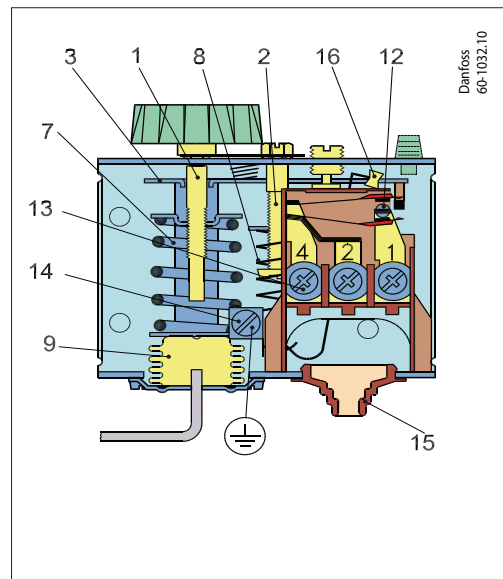

The switch in the KP has a snap-action function and the bellows move only when the cut-in or cut-out value is reached.

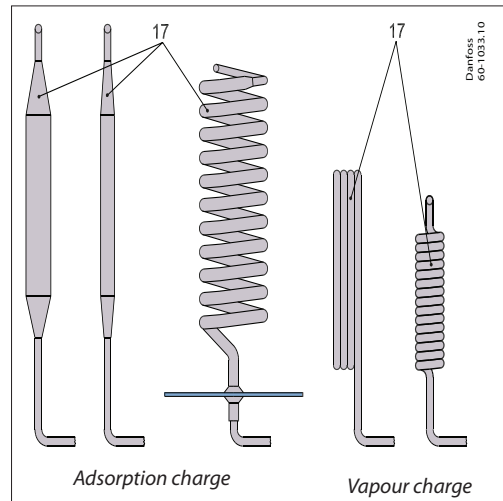

The design of the KP thermostats affords the following advantages:

- high contact load,
- ultra-short bounce time,
- vibration resistance up to 4 g, in the range 0 – 1000 Hz,
- long mechanical and electrical life.

Thermostat, type KP

Design / function (continued)

KP thermostat, dual type

1. Temperature setting spindle, OIL
3. Main arm
5. Temperature setting spindle, HT
7. Main spring
9. Bellows
10. Capillary tube, OIL
11. Capillary tube, HT
12. Switch
13. Terminals
14. Earth terminal
15. Cable entry
16. Tumbler
17. Sensor (bulb)
18. Locking plate

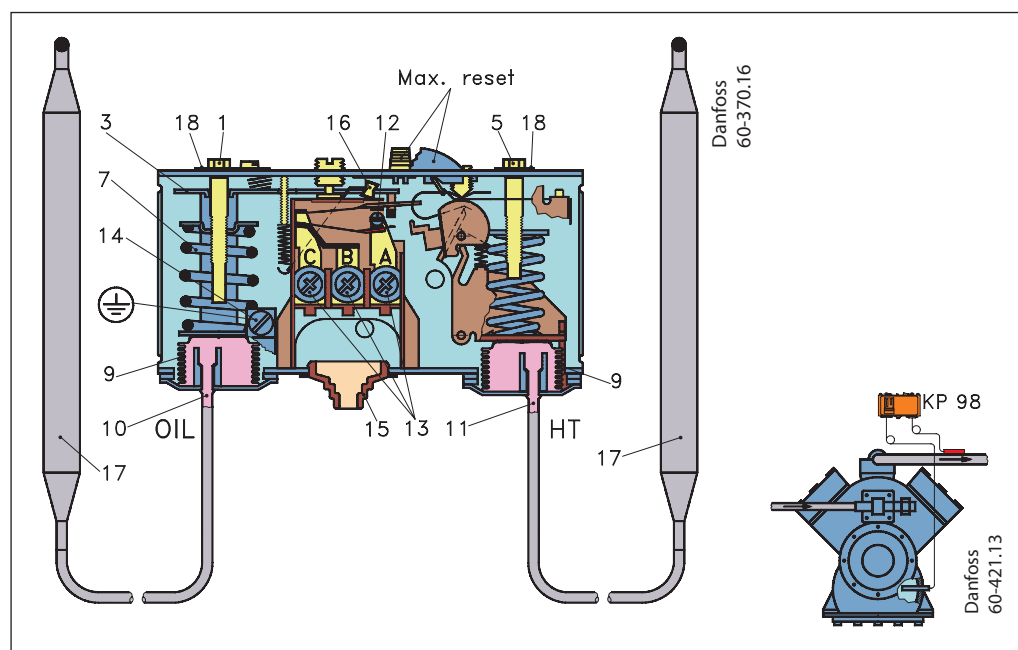

Dual thermostat KP 98 is used to provide protection against excessively high discharge gas temperature and to ensure a suitable oil temperature in the compressor. To avoid the temperature of the hot gas exceeding the maximum permissible value during extreme operating conditions (low evaporating pressure, high condensing pressure, high suction vapour superheat) a KP 98 thermostat can be used on the high temperature side (HT). If the temperature of the hot gas becomes too high the refrigerant will break down and the compressor discharge valve will become damaged.

The risk is greatest in refrigeration systems that operate on a high compression ratio (e.g. in systems with NH₃ or R22) and in applications with hot gas bypass. This unit has two separate thermostat functions. The HT sensor that controls the discharge gas temperature is fitted on the discharge tube immediately after the compressor. For larger compressors, the sensor can be built into the discharge line. The OIL sensor that controls the oil temperature is located in the compressor oil sump.

Terminology

Differential

The differential is the difference between the make and break temperatures. A differential is necessary for satisfactory automatic operation of the plant.

Mechanical differential (intrinsic differential)

The mechanical differential is the differential set by the differential spindle.

Operating differential (thermal differential)

The operating differential is the differential the plant operates on. Operating differential is the sum of the mechanical differential and the differential produced by the time constant.

Reset

1. Manual reset:

Units with manual reset can only be restarted after the reset button has been activated. On min. reset units the set value is equal to the cut-out value for falling temperature. On max. reset units the set value is equal to the cut-out value for rising temperature.

2. Automatic reset:

These units are automatically reset after operational stop.

Thermostat, type KP

Setting

Thermostats with automatic reset

Set the upper activating temperature on the range scale.
 Set the differential on the "DIFF" scale.
 The temperature setting on the range scale will then correspond to the temperature at which the refrigeration compressor will be started on rising temperature. The compressor will be stopped when the temperature has fallen in relation to the differential setting.
 Note that the differential depends on the range setting. Therefore, the differential scale must only be used as guideline.
 If with low stop temperature settings the compressor will not stop, check whether the differential is set at too high a value!

Thermostats with minimum reset

Set the stop temperature on the range scale.
 The differential is a fixed setting.
 The compressor can be restarted by pressing the "Reset button" after the temperature on the thermostat sensor has risen by a value equal to the fixed differential setting.

Thermostats with maximum reset

Set the stop temperature on the range scale.
 The differential is a fixed setting.
 The compressor can be restarted by pressing the "Reset button" after the temperature on the thermostat sensor has fallen to a value equal to the fixed differential setting.

Charges

1. Vapour charge

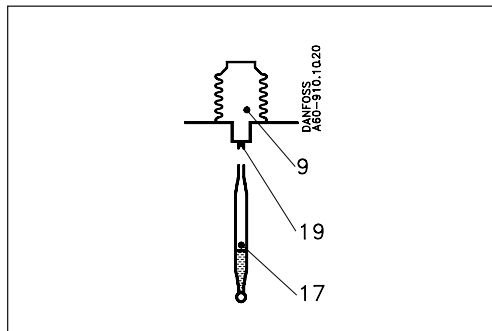

- 9. Bellows element
- 17. Sensor (bulb)
- 19. Capillary tube

Here the interdependence between the pressure and temperature of saturated vapour is utilized, i.e. the element is charged with saturated vapour plus a small amount of liquid.
 The charge is pressure-limited; a further increase in pressure after evaporation of all the liquid in the sensor (17) will only result in a small pressure increase in the element.

This principle can be utilized in thermostats for low temperature, etc. where evaporation must be able to take place from the free liquid surface in the sensor (within the operating range of the thermostat), and where at the same time, the bellows must be protected against deformation when kept at normal ambient temperatures.
 Since the pressure in the element depends on the temperature at the free liquid surface, the thermostat must always be placed so that the sensor is colder than the rest of the thermostatic element.

The evaporated liquid will recondense at the coldest point, i.e. the sensor. Thus, as intended, the sensor becomes the temperature-controlling part of the system.

Note: When the sensor is coldest, the ambient temperature has no effect on regulating accuracy.

2. Adsorption charge

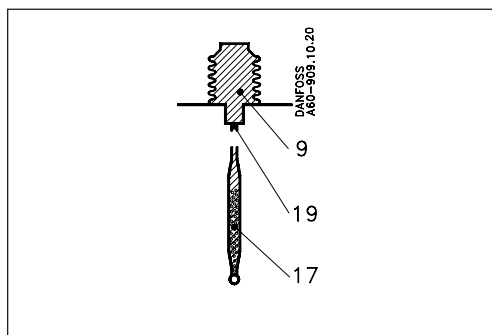

- 9. Bellows element
- 17. Sensor (bulb)
- 19. Capillary tube

In this case the charge consists partly of a superheated gas and partly of a solid having a large adsorption surface.
 The solid is concentrated in the sensor (17) and it is therefore always the sensor that is the temperature-controlling part of the thermostatic element.
 The sensor can be placed warmer or colder than thermostat housing and capillary tube, but variations from 20 °C ambient temperature will influence the scale accuracy.

Thermostat, type KP

Dimensions [mm] and weights [kg]

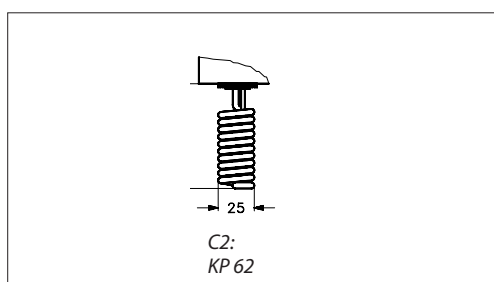
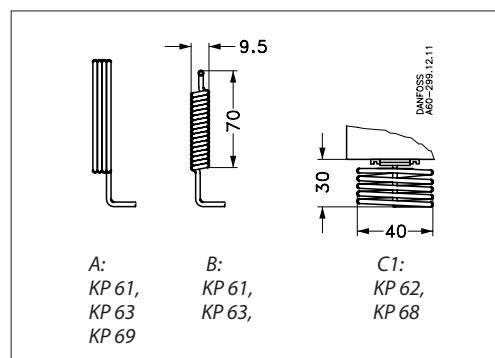
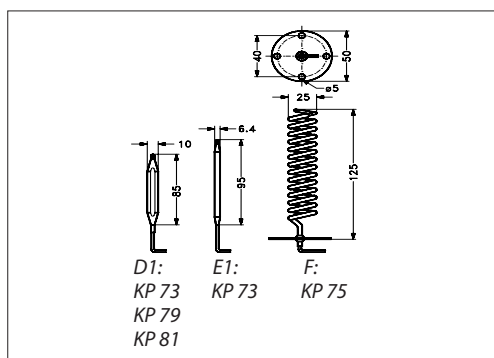
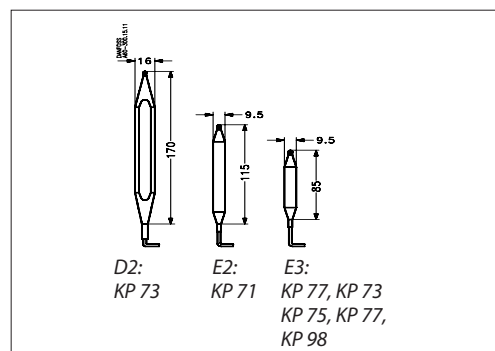
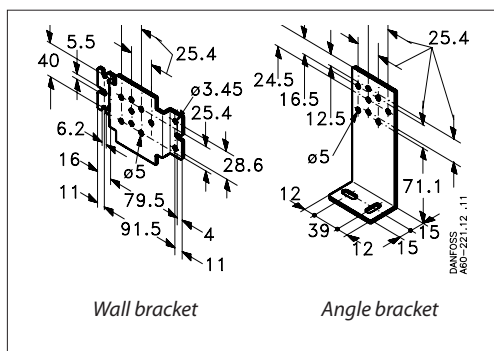
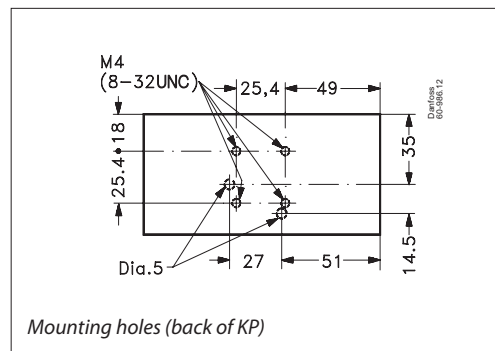
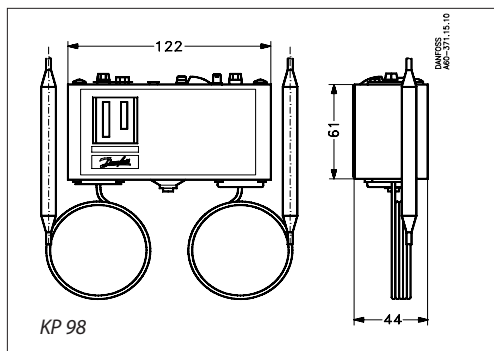
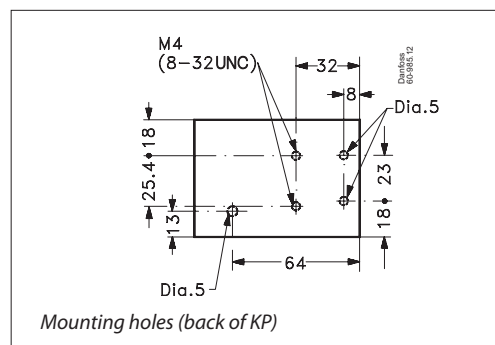
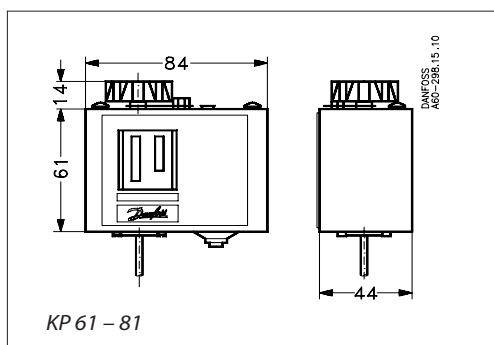

Net weight:
KP 61 – 81: approx. 0.4 kg
KP 98: approx. 0.6 kg

Pressure switch

KP

Contents

	Page
Features	17
Approvals	17
Ship approvals	17
Technical data	18
Materials in contact with the medium	19
Ordering	20
Design / Function	22
Terminology	24
Setting	24
Dimensions [mm] and weights [kg]	25

Pressure switch

KP



KP pressure switches are for use in refrigeration and air conditioning systems to give protection against excessively low suction pressure or excessively high discharge pressure.

KP pressure switches are also used for starting and stopping refrigeration compressors and fans on air-cooled condensers.

A KP pressure switch can be connected directly to a single-phase AC motor of up to approx. 2 kW or installed in the control circuit of DC motors and large AC motors.

KP pressure switches are fitted with a single-pole double-throw (SPDT) switch. The position of the switch is determined by the pressure switch setting and the pressure at the connector. KP pressure switches are available in IP30, IP44 and IP55 enclosures.

Features

- Ultra-short bounce time thanks to snap-action function (reduces wear to a minimum and increases reliability)
- Manual trip function (electrical contact function can be tested without the use of tools)
- Types KP 6, KP 7 and KP 17 with fail-safe double bellows element
- Vibration and shock resistant
- Compact design
- Fully welded bellows element
- High reliability both electrically and mechanically

Approvals

CE-marked in accordance with:
 – LVD 2014/35/EU
 (EN 60947-1, EN 60947-4-1, EN 60947-5-1)
 – PED 2014/68/EU, category IV (EN 12263):
 KP 1, KP 2, KP 6, KP 7 and KP 17

Underwriters Laboratories Inc., UL listed
 China Compulsory Certificate, CCC

Ship approvals

Germanischer Lloyd, GL
 Det Norske Veritas, Norway, DNV
 Registro Italiano Navale, RINA

Bureau Veritas, BV
 Lloyd's Register, LR
 Russian Maritime Register of Shipping, RMRS

Pressure switch, KP

Technical data

Ambient temperature		-40 – 65 °C (80 °C for max. 2 hours).
Ambient temperature (PED approved units)		-25 – 65 °C (80 °C for max. 2 hours).
Media temperature *)		-50 – 100 °C
Max. working pressure		LP: PS / MWP = 17 bar
		HP: PS / MWP = 35 bar
		KP 6: PS / MWP = 46.5 bar
Max. test pressure		LP: P _e = 20 bar
		HP: P _e = 35 bar
		KP 6: P _e = 46.5 bar
Contact load	Alternating current	AC1 = 16 A, 400 V AC3 = 16 A, 400 V AC15 = 10 A, 400 V
	Direct current	DC13 = 12 W, 220 V control current
Wire dimensions	solid / stranded	0.75 – 2.5 mm ²
	flexible, without ferrules	0.7 – 2.5 mm ²
	flexible, with ferrules	0.5 – 1.5 mm ²
Tightening torque		max. 2 Nm
Rated impulse voltage		4 kV
Pollution degree		3
Short circuit protection, fuse		16 A
Insulation		400 V
Enclosure		IP30 / IP44 / IP55

*) The media temperature can be out of ambient temperature range under necessary condition that temperature inside KP must be kept in ambient temperature range.

Contact systems

Low pressure (LP)		High pressure (HP)			
<p>SPDT</p> <p>DANFOSS A60-943.13</p>		<p>SPDT</p> <p>DANFOSS A60-944.13</p>			
Dual pressure (LP/HP)		Dual pressure (LP/HP)		Dual pressure (HP/HP)	
<p>SPDT+LP signal</p> <p>DANFOSS 60-591.15</p>		<p>SPDT+LP+HP signal</p> <p>DANFOSS A60-593.14</p>		<p>SPST</p> <p>DANFOSS A60-306.17</p>	

Pressure switch, KP

Technical data (continued)

Cable connection

The cable entry can be used for 6 – 14 mm dia. cables. A Pg 13.5 screwed cable entry can also be used for 6 – 14 mm cable. With 8 – 16 mm cable a standard Pg 16 screwed cable entry can be used.

Enclosure

IP30 to EN 60529 / IEC 60529

Enclosure IP30 is obtained when the units without top cover are mounted on a flat surface or bracket. The bracket must be fixed to the unit so that all unused holes are covered.

IP44 to EN 60529 / IEC 60529

Enclosure IP44 is obtained when the units with top cover are mounted on a flat surface or bracket. The bracket must be fixed to the unit so that all unused holes are covered.

KP pressure switches with auto reset are supplied with top cover. For KP pressure switches with manual reset, the top cover must be separately ordered (**code no. 060-109766** for single pressure switches and **code no. 060-109866** for dual pressure switches).

IP55 to EN 60529 / IEC 60529

IP55 is obtained when the KP pressure switches are mounted in an IP55 enclosure, (**code no. 060-033066** for single pressure switches and **code no. 060-035066** for dual pressure switches).

IP55 enclosure has to be ordered separately.

Materials in contact with the medium

Type	Material
KP 1, KP 2, KP 5, KP 6, KP 7, KP 15 and KP 17	Tinbronze, no. CW452K, EN 1652
	Nickel plated free cutting steel, no. 1.0737 / 1.0718, EN 10277
KP 1A, KP 5A, KP 6A, KP 7A and KP 15A only	Stainless steel 18/8, no. 1.4306, EN 10088-2
	Free cutting steel, no. 1.0737, EN 10277
	Cold forming steel, no. 1.0338, EN 10139
	Steel, no 1.0308, EN 10305
	Free cutting steel, no. 1.0715, EN10277
	Free cutting steel, no. 1.0718, EN 10277
	Aluminium, no. AW-3005, EN 573

Pressure switch, KP

Ordering

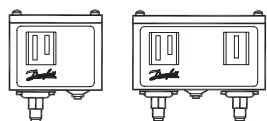

For R22, R134a, R404A, R407A, R407C, R407F, R422B, R422D, R438A, R448A, R449A, R450A, R452A, R507A, R513A

For complete list of approved refrigerants, visit www.products.danfoss.com and search for individual code numbers, where refrigerants are listed as part of technical data.

Pressure	Type	Low pressure (LP)		High pressure (HP)		Reset		Contact system	Code no.		
		Regulating range [bar]	Differential Δp [bar]	Regulating range [bar]	Differential Δp [bar]	Low pressure LP	High pressure HP		Connection		
									1/4 in. 6 mm flare	1/4 in. ODF solder	6 mm ODF solder
Low	KP 1	-0.2 – 7.5	0.7 – 4.0	–	–	Auto	–	SPDT	060-110166 ¹⁾)	060-111266 ⁴⁾)	060-111066 ⁴⁾)
Low	KP 1	-0.2 – 7.5	0.7 – 4.0	–	–	Auto	–	SPDT	060-114166 ²⁾)	–	–
Low	KP 1	-0.9 – 7.0	0.7	–	–	Man. (Min.)	–	SPDT	060-110366 ¹⁾)	060-111166	060-110966
Low	KP 2	-0.2 – 5.0	0.4 – 1.5	–	–	Auto	–	SPDT	060-112066 ¹⁾)	–	060-112366 ⁴⁾)
High	KP 5	–	–	8 – 32	1.8 – 6.0	–	Auto	SPDT	060-117166 ¹⁾)	060-117966 ⁴⁾)	060-117766 ⁴⁾)
High	KP 5	–	–	8 – 32	3	–	Man. (Max.)	SPDT	060-117366 ¹⁾)	060-118066	–
Dual	KP 15	-0.2 – 7.5	0.7 – 4.0	8 – 32	4	Auto	Auto	SPDT + LP signal	060-124166 ⁴⁾)	060-125466 ⁴⁾)	–
Dual	KP 15	-0.2 – 7.5	0.7 – 4.0	8 – 32	4	Auto	Man. (Max.)	SPDT + LP signal	060-124366 ¹⁾)	–	–
Dual	KP 15	-0.2 – 7.5	0.7 – 4.0	8 – 32	4	Auto	Man. (Max.)	SPDT + LP signal	060-114866 ²⁾)	–	–
Dual	KP 15	-0.9 – 7.0	0.7	8 – 32	4	Man. (Min.)	Man. (Max.)	SPDT + LP signal	060-124566 ¹⁾)	–	–
Dual	KP 15	-0.9 – 7.0	0.7	8 – 32	4	Conv. ³⁾	Conv. ³⁾	SPDT + LP signal	060-126166	–	–
Dual	KP 15	-0.2 – 7.5	0.7 – 4.0	8 – 32	4	Auto	Auto	SPDT + LP and HP signal	060-126566 ¹⁾)	060-129966 ⁴⁾)	–
Dual	KP 15	-0.2 – 7.5	0.7 – 4.0	8 – 32	4	Auto	Man. (Max.)	SPDT + LP and HP signal	060-126466 ¹⁾)	060-128466 ¹⁾)	–
Dual	KP 15	-0.2 – 7.5	0.7 – 4.0	8 – 32	4	Conv. ³⁾	Conv. ³⁾	SPDT + LP and HP signal	060-115466 ⁴⁾)	060-001066 ⁴⁾)	–
Dual	KP 15	-0.9 – 7.0	0.7	8 – 32	4	Conv. ³⁾	Conv. ³⁾	SPDT + LP and HP signal	060-122066	–	–

For R717, R22, R134a, R404A, R407A, R407C, R407F, R422B, R422D, R438A, R448A, R449A, R450A, R452A, R507A, R513A

For complete list of approved refrigerants, visit www.products.danfoss.com and search for individual code numbers, where refrigerants are listed as part of technical data.

Pressure	Type	Low pressure (LP)		High pressure (HP)		Reset		Contact system	Code no.	
		Regulating range [bar]	Differential Δp [bar]	Regulating range [bar]	Differential Δp [bar]	Low pressure LP	High pressure HP		Connection	
									M10 × 0.75	1 m cap. tube with M10 × 0.75
Low	KP 1A	-0.2 – 7.5	0.7 – 4.0	–	–	Auto	–	SPDT	060-116266 ¹⁾)	060-116066 ⁴⁾)
Low	KP 1A	-0.9 – 7.0	0.7	–	–	Man. (Min.)	–	SPDT	–	060-116166
High	KP 5A	–	–	8 – 32	1.8 – 6.0	–	Auto	SPDT	–	060-123066 ⁴⁾)
High	KP 5A	–	–	8 – 32	3	–	Man. (Max.)	SPDT	060-115366 ¹⁾)	060-123166
Dual	KP 15A	-0.2 – 7.5	0.7 – 4.0	8 – 32	4	Auto	Auto	SPDT + LP and HP signal	060-129566	060-129366 ⁴⁾)
Dual	KP 15A	-0.2 – 7.5	0.7 – 4.0	8 – 32	4	Auto	Man. (Max.)	SPDT + LP and HP signal	060-129666	060-129466
Dual	KP 15A	-0.9 – 7.0	0.7	8 – 32	4	Conv. ³⁾	Conv. ³⁾	SPDT + LP signal	–	060-128366

¹⁾ Available in Asia market with code 060-xxxx91

²⁾ Pressure switches with gold-plated contacts

³⁾ Conv.: optional automatic or manual reset

⁴⁾ Enclosure IP44

Pressure switch, KP

Pressure switches PED 2014/68/EU approved; EN 12263

For R22, R134a, R404A, R407A, R407C, R407F, R410A*), R422B, R422D, R438A, R448A, R449A, R450A, R452A, R507A, R513A

*) for KP6W, KP6B

For complete list of approved refrigerants, visit www.products.danfoss.com and search for individual code numbers, where refrigerants are listed as part of technical data.

Pressure	Type ¹⁾	Low pressure (LP)		High pressure (HP)		Reset		Contact system	Code no.	
		Regulating range [bar]	Differential Δp [bar]	Regulating range [bar]	Differential Δp [bar]	Low pressure LP	High pressure HP		^{1/4} in. 6 mm flare	6 mm ODF solder
Low	KP 1	-0.2 – 7.5	0.7 – 4.0	–	–	Auto	–	SPDT	060-110166 ²⁾³⁾	060-111066 ³⁾
Low	KP 1	-0.9 – 7	0.7	–	–	Man. (Min.)	–	SPDT	060-110366 ²⁾	060-110966
Low	KP 2	-0.2 – 5	0.4 – 1.5	–	–	Auto	–	SPDT	060-112066 ^{2) 3)}	060-112366 ³⁾
High	KP 6W	–	–	8 – 42	4 – 10	–	Auto	SPDT	060-519066 ³⁾	–
High	KP 6B	–	–	8 – 42	4	–	Man. (Max.)	SPDT	060-519166	–
High	KP 7W	–	–	8 – 32	4 – 10	–	Auto	SPDT	060-119066 ³⁾	060-120366 ³⁾
High	KP 7B	–	–	8 – 32	4	–	Man. (Max.)	SPDT	060-119166	–
High	KP 7S	–	–	8 – 32	4	–	Man. (Max.)	SPDT	060-119266 ³⁾	–
Dual	KP 7BS	–	–	8 – 32	4	–	Man. (Max.) Man. (Max.)	SPST	060-120066	–
Dual	KP 17W	-0.2 – 7.5	0.7 – 4	8 – 32	4	Auto	Auto	SPDT + LP and HP signal	060-127566 ³⁾	060-127666 ³⁾
Dual	KP 17W	-0.2 – 7.5	0.7 – 4	8 – 32	4	Auto	Auto	SPDT+ LP signal	060-126766 ³⁾	–
Dual	KP 17B	-0.2 – 7.5	0.7 – 4	8 – 32	4	Auto	Man. (Max.)	SPDT	060-126866	060-127466
Dual	KP 17WB	-0.2 – 7.5	0.7 – 4	8 – 32	4	Auto	Conv. ⁵⁾	SPDT + LP and HP signal	060-539766 ³⁾⁴⁾	–

For R717, R22, R134a, R404A, R407A, R407C, R407F, R422B, R422D, R438A, R448A, R449A, R450A, R452A, R507A, R513A

For complete list of approved refrigerants, visit www.products.danfoss.com and search for individual code numbers, where refrigerants are listed as part of technical data.

Pressure	Type	Low pressure (LP)		High pressure (HP)		Reset		Contact system	Code no.	
		Regulating range [bar]	Differential Δp [bar]	Regulating range [bar]	Differential Δp [bar]	Low pressure LP	High pressure HP		M10 x 0.75	1 m cap. tube with M10 x 0.75
Low	KP 1A	-0.2 – 7.5	0.7 – 4.0	–	–	Auto	–	SPDT	060-116266 ²⁾	060-116066 ³⁾
Low	KP 1A	0.9 – 7	Fixed 0.7	–	–	Man. (Min.)	–	SPDT	–	060-116166
Dual	KP 7ABS	–	–	8 – 32	Fixed 4	–	Man. (Max.) Man. (Max.)	SPST	–	060-120566

¹⁾ W = PSH (pressure switch), B = PZH (pressure switch with ext. reset), S = PZHH (pressure switch with int. reset)

²⁾ Available in Asia market with code 060-xxxx91

³⁾ Enclosure IP44

⁴⁾ Factory setting: LP side: Range 1 bar Pe, Diff. 1 bar; HP side: Range 18 bar Pe, Diff. 4 bar fixed

⁵⁾ Conv.: optional automatic or manual reset

Pressure switch setting with convertible reset

Low pressure	Manual reset ¹⁾	Automatic reset	Automatic reset	Manual reset
High pressure	Manual reset ¹⁾	Manual reset	Automatic reset	Automatic reset

¹⁾ Factory setting

Pressure switch, KP

Design / Function

Pressure switch, type KP

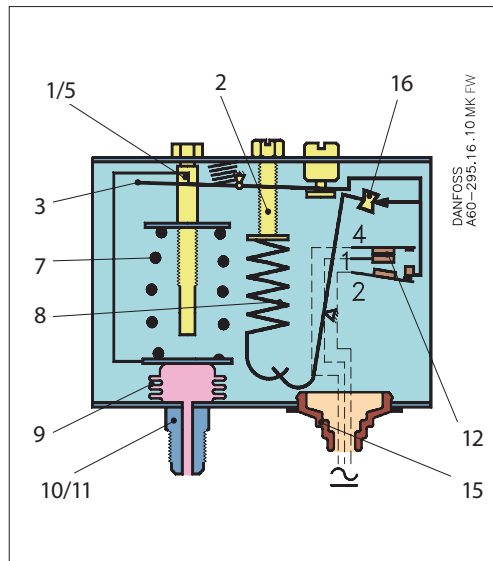

KP 1, KP 2, KP 5

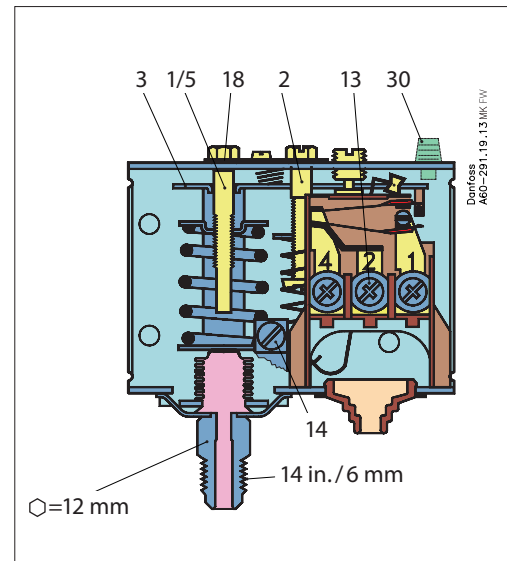

KP 15

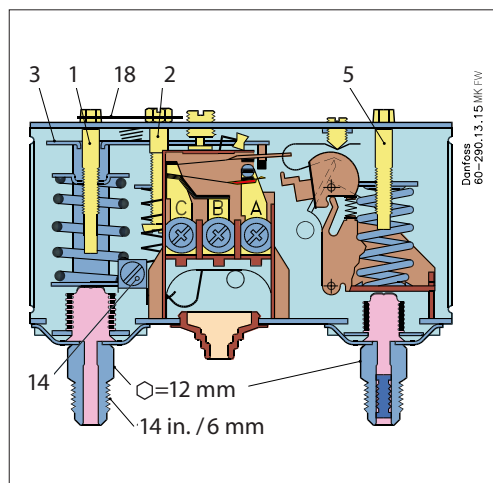

1. Low pressure (LP) setting spindle
2. Differential setting spindle, (LP)
3. Main arm
5. High pressure (HP) setting spindle
7. Main spring
8. Differential spring
9. Bellows
10. LP connection
11. HP connection
12. Switch
13. Terminals
14. Earth terminal
15. Cable entry
16. Tumbler
18. Locking plate
30. Reset button

Capillary tube for KP 1A, KP 5A and KP 15A

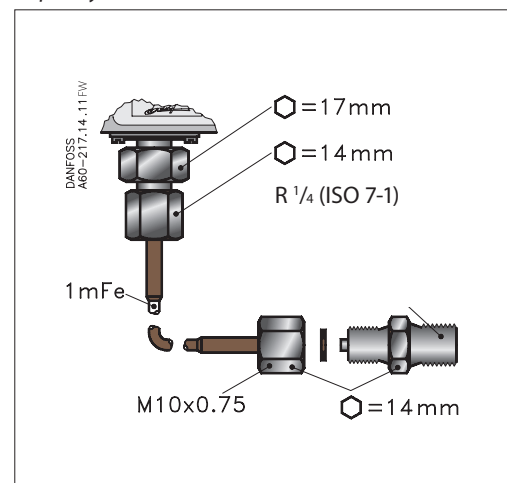

The switch in the KP has a snap-action function and the bellows moves only when the cut-in or cut-out value is reached.

The bellows becomes connected to the low or high pressure side of the plant through connection (10) or (11).

The design of the KP pressure switch gives the following advantages:

- ▮ high contact load
- ▮ ultra-short bounce time
- ▮ high resistance to pulsation
- ▮ vibration resistance up to 4 g in the range 0 – 1000 Hz
- ▮ long mechanical and electrical life

Pressure switch, KP

Design (continued)

KP 7W, flare

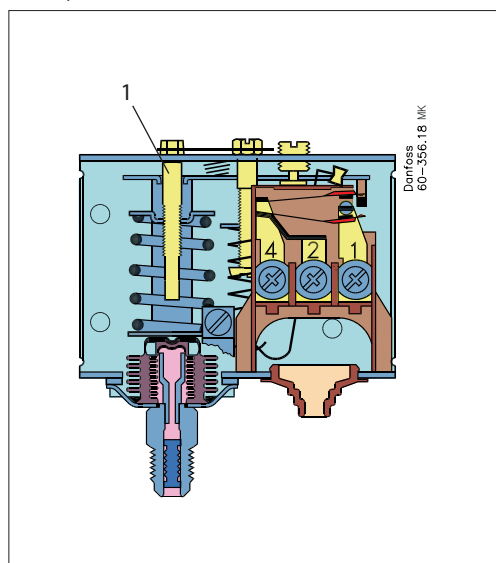

KP 7W, solder

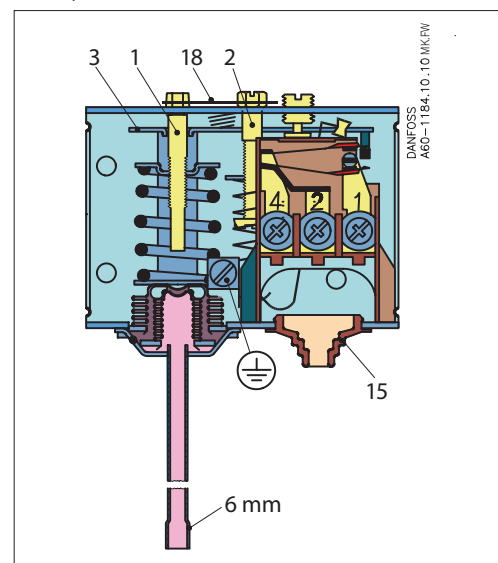

KP 7BS

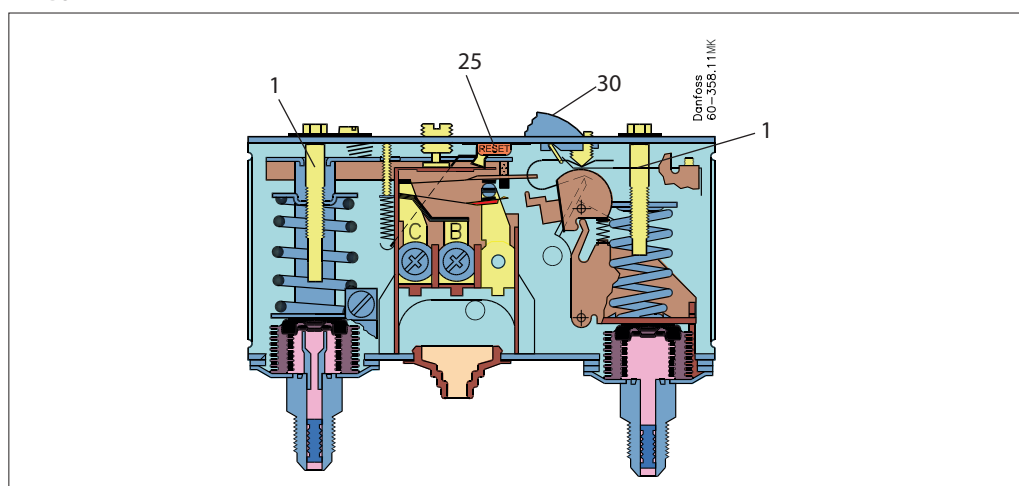

- 1. Pressure setting spindle
- 2. Differential setting spindle
- 3. Main arm
- 15. Cable entry
- 18. Locking plate
- 25. Int. reset arm
- 30. Ext. reset button

Types KP1, KP1A, KP2, KP6, KP6A, KP7 and KP17 units with designation W, B or S have been tested and approved by TÜV, Rheinland in accordance with EN 12263.

Types KP6, KP6A, KP7 and KP17 have a double bellows: an outer bellows and a regulating bellows. When system pressure exceeds the set value, the KP will automatically stop the plant. The double bellows system prevents loss of charge in the event of bellows rupture.

A rupture in the inner bellows will cause the control cut-out pressure to fall about 3 times less the set value, thus the refrigeration plant compressor will stop.

A rupture in the outer bellows will cause the control cut-out pressure to fall to about 3 bar under the set value, thus providing a fail-safe function.

Versions with designation W or AW cut in again automatically when the pressure has fallen to the set value minus the differential.

Versions with designation B or AB can be cut in manually with the external reset button when the pressure in KP1 has increased 0.7 bar above set value and in KP6 and KP7 has fallen 4 bar under the set value.

Versions with designation S or AS can be cut in manually with the internal reset arm when the pressure has fallen 4 bar under the set value.

All KP pressure switches, including those which are PED-approved, operate independently of changes in the ambient temperature around the control housing. Therefore the set cut-out pressure and differential are held constant provided the permissible ambient temperatures are not exceeded.

Terminology

Reset

1. **Manual (Min. / Max.) reset:**
Units with manual reset can only be reset during operation by activation of the reset button
2. **Automatic reset:**
After operational stop, these units reset automatically
3. **Convertible reset:**
Units with optional reset can be activated by automatic and/or manual reset

Permissible working pressure

The permissible working pressure is determined by the pressure that can be safely allowed in the refrigerating system or any of the units within it.

Test pressure

The test pressure is the pressure used in strength tests and/or leakage tests on refrigerating systems or individual parts in systems. The test pressure is designated P_e .

“Snap function”

A certain contact force is maintained until irrevocable “snap” is initiated. The time during which the contact force approaches zero is thus limited to a very few milliseconds. Therefore contact bounce cannot occur as a result of, for example, slight vibrations, before the cut-out point. Contact systems with “Snap function” will change over even when micro-welds are created between the contacts during cut-in. A very high force is created during cut-out to separate the contacts. This force immediately shears off all the welds. Thus the cut-out point of the unit remains very accurate and completely independent of the magnitude of the current load.

Setting

Pressure switches with automatic reset – LP:

Set the LP start pressure on the “CUT-IN” scale (range scale). One rotation of the low pressure spindle ~ 0.7 bar. Set the LP differential on the “DIFF” scale. One rotation of the differential spindle ~ 0.15 bar. The LP stop pressure is the LP start pressure minus the differential.

Note:

The LP stop pressure must be above absolute vacuum ($P_e = -1$ bar)!

If with low stop pressure the refrigeration compressor will not stop, check to ensure that the differential value has not been set too high!

Pressure switches with automatic reset – HP:

Set the HP pressure on the “CUT-OUT” scale. One rotation of the HP spindle ~ 2.3 bar. Set the HP differential on the “DIFF” scale. One rotation of the differential spindle ~ 0.3 bar. The HP start pressure is the HP stop pressure minus the differential.

Start and stop pressures for both the LP and HP sides of the system should always be checked with an accurate pressure gauge.

Pressure switches with manual reset

Set the stop pressure on “CUT-OUT” scale (range scale).

Low pressure switches can be manually reset when the pressure is equal to the stop pressure plus the differential.

High pressure switches can be manually reset when the pressure is equal to the stop pressure minus the differential.

Pressure switch, KP

**Dimensions [mm]
and weights [kg]**

Pressure switches with flare connection

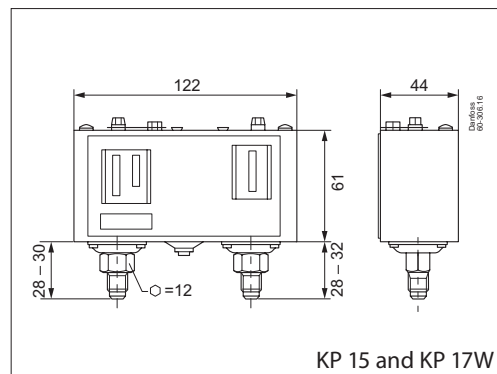
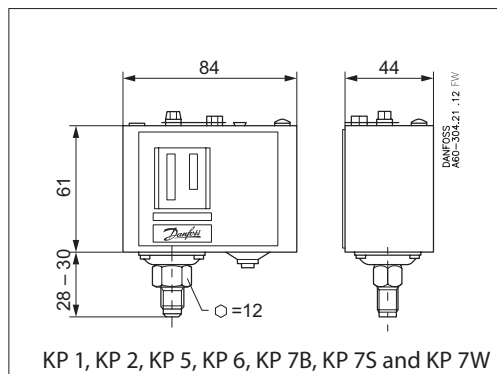

M10 x 0.75 connection

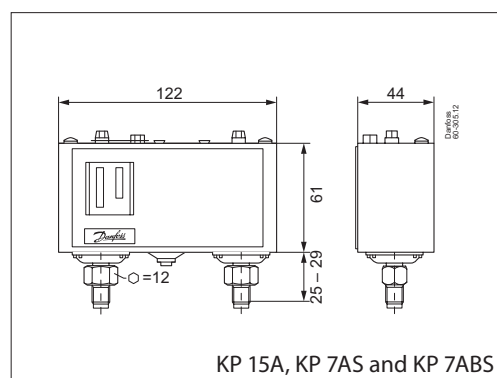
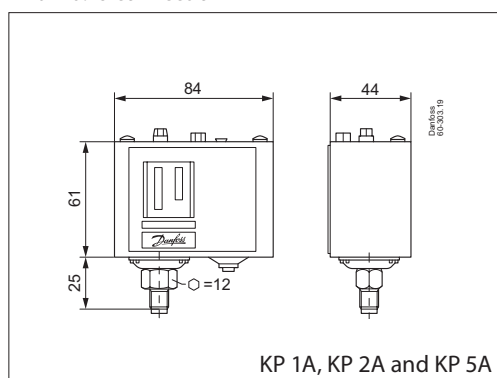

Solder connection

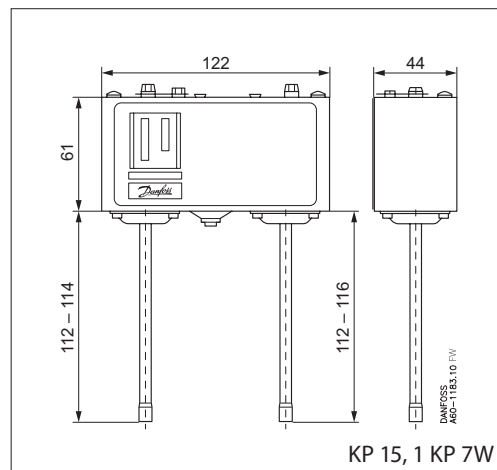
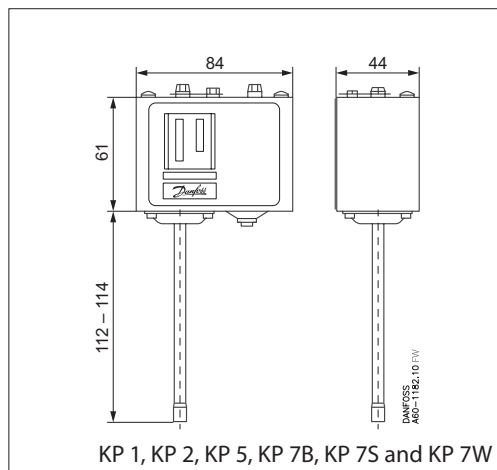

KP with top cover

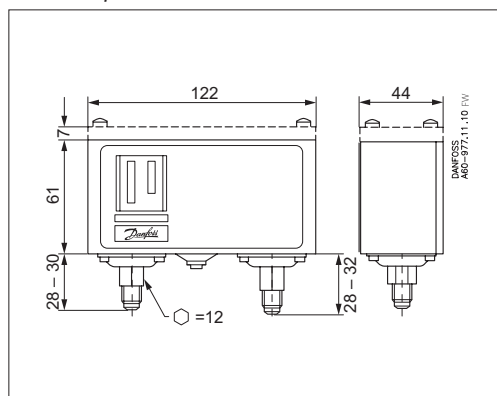

Net weight:

- KP 1, KP 2, KP 5 and KP 7: approx. 0.3 kg
- KP 15, KP 17 and KP 7BS: approx. 0.5 kg
- KP 1A and KP 5A: approx. 0.3 kg
- KP 15A and KP 7ABS: approx. 0.5 kg

Pressure switch, KP

**Dimensions [mm]
and weights [kg]**
(continued)

IP55 enclosure

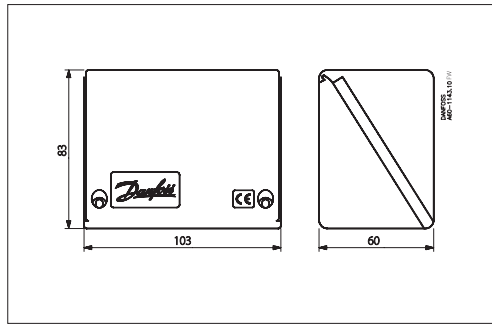

IP55 enclosure for dual types

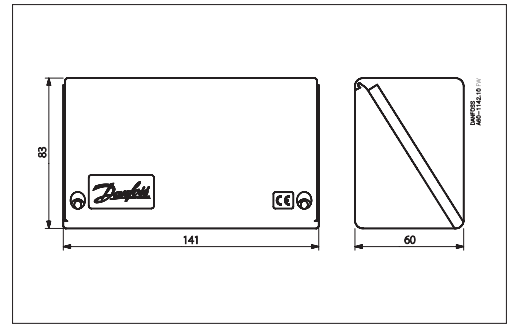

Weld nipple for KP-A

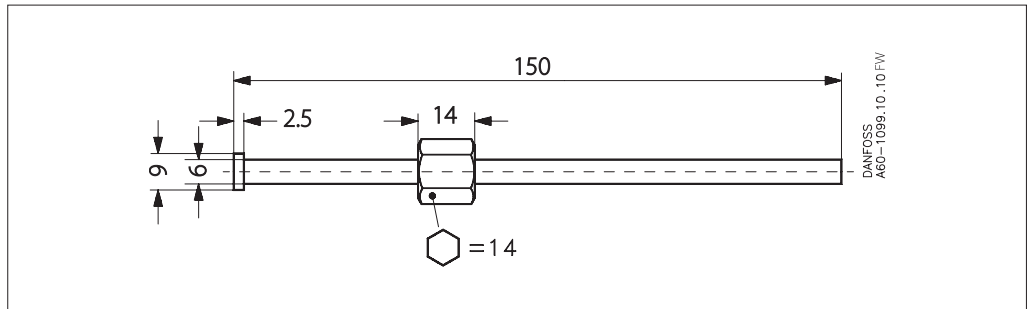

Thermostat, Differential thermostat RT

Contents

	Page
Features	29
Approvals	30
Technical data	30
Ordering	32
Design / Function	35
Terminology	36
Charges	37
Setting of differential	38
Nomograms for obtained differentials	40
Dimensions and weights	42

Thermostat, Differential thermostat

RT



An RT thermostat is fitted with a single-pole changeover switch.

The position of the contacts depends on the bulb temperature and the set scale value.

The RT series includes thermostats for general applications within industrial and marine refrigeration.

The RT series also includes differential thermostats, thermostats for neutral zone regulation and special thermostats with gold-plated contact surface for PLC applications.

Features

- Waterproof versions, enclosure IP66
- Wide regulating range
- Wide range of units for industrial and marine applications
- Suitable for alternating and direct current
- Interchangeable contact system
- Special versions for PLC applications
- Safety Integrity Level: SIL 2 according to IEC 61508

Thermostat, Differential thermostat, type RT

Approvals

RT 2	RT 3	RT 4	RT 7	RT 8	RT 8L	RT 9	RT 11	RT 12	RT 13	RT 14	RT 14L	RT 15	RT 16L	RT 17	RT 23	RT 24	RT 34	RT 101	RT 102	RT 107	RT 140	RT 140L	RT 270			
																									Lloyd's Reg. of Shipping, LR	
	•			•	•	•			•	•	•	•							•		•				Germanischer Lloyd, GL	
																			•		•				Det Norske Veritas, DNV	
																			•						Bureau Veritas, BV	
•	•	•	•	•	•	•	•	•	•	•	•	•	•	•	•	•	•	•	•	•	•	•	•	•	•	Russian Maritime Register of Shipping, RMRS
•	•		•					•	•	•		•			•						•				Nippon Kaiji Kyokai, NKK	
																					•				Korean Register of Shipping, KRS	
•	•	•	•	•	•	•	•	•	•	•	•	•	•	•	•	•	•	•	•	•	•	•	•	•	•	Conformity with EN 60730-2-1 to 9
•	•	•	•	•	•	•	•	•	•	•	•	•	•	•	•	•	•	•	•	•	•	•	•	•	•	CE mark according to EN 60947-4, -5
•	•	•	•	•	•	•	•	•	•	•	•	•	•	•	•	•	•	•	•	•	•	•	•	•	•	China Compulsory Certificate, CCC

Technical data

Cable connection	Pg 13.5. Cable diameter 6 – 14 mm.
Enclosure	IP66 acc. to EN 60529 / IEC 60529, except for versions with ext. reset which are IP54.
Permissible ambient temperature	-50 – 70 °C for thermostat housing.
Switches	See "Ordering switches"

Properties according to EN 60947

Wire dimensions	
solid / stranded	0.2 – 2.5 mm ²
flexible, w / out ferrules	0.2 – 2.5 mm ²
flexible, with ferrules	0.2 – 1.5 mm ²
Tightening torque	max. 1.5 Nm
Rated impulse voltage	4 kV
Pollution degree	3
Short circuit protection, fuse	10 A
Insulation	400 V
Ingress Protection	IP54, IP66

Thermostat, Differential thermostat, type RT

Overview

[°C]		Range [°C]	Type						
-50	0	50	100	150	200	250	300		
Vapour-charged with remote bulb (bulb coldest)								-45 – -15	RT 9
								-30 – 0	RT 13
Vapour-charged with remote bulb (bulb warmest)								-25 – 15	RT 3
								-25 – 15	RT 2, RT 7
Vapour-charged with coiled capillary tube sensor (room thermostats)								-20 – 12	RT 8
								-5 – 10	RT 12
Adsorption-charged with remote bulb (bulb warmest or coldest)								-5 – 30	RT 14
								5 – 22	RT 23
Adsorption-charged with coiled capillary tube sensor (room thermostats)								8 – 32	RT 15
								15 – 34	RT 24
Partial charge with remote bulb (bulb warmest)								15 – 45	RT 140
								25 – 90	RT 101, RT 102
Vapour-charged dead zone thermostat (room thermostat)								70 – 150	RT 107
								-50 – -15	RT 17
Adsorption-charged differential thermostats with remote bulb (bulb warmest or coldest)								-30 – 0	RT 11
								-5 – 30	RT 4
Vapour-charged dead zone thermostat (room thermostat)								-25 – 15	RT 34
								-20 – 12	RT 8L
Adsorption-charged dead zone thermostats with remote bulb (bulb warmest or coldest)								-5 – 30	RT 14L
								15 – 45	RT 140L
Adsorption-charged differential thermostats with remote bulb (bulb warmest or coldest)								0 – 38	RT 16L
								-30 – 40	RT 270

Thermostat, Differential thermostat, type RT

Ordering

Thermostats

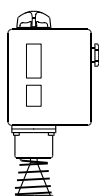
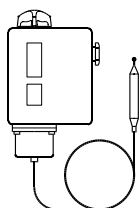

Charge	Type	Bulb type	Regulation range [°C]	Differential Δt		Reset	Max. bulb temp. [°C]	Capillary tube length [m]	Code no.
				At min. range setting [K]	At max. range setting [K]				
Vapour ¹⁾	RT 9	A	-45 – 15	2.2 – 10.0	1.0 – 4.5	auto	150	2	017-506666
	RT 3	A	-25 – 15	2.8 – 10.0	1.0 – 4.0	auto	150	2	017-501466
	RT 17	B	-50 – -15	2.2 – 7.0	1.5 – 5.0	auto	100	–	017-511766
	RT 11	B	-30 – 0	1.5 – 6.0	1.0 – 3.0	auto	66	–	017-508366
	RT 4	B	-5 – 30	1.5 – 7.0	1.2 – 4.0	auto	75	–	017-503666 017-503766 ⁴⁾
Adsorption ²⁾	RT 13	A	-30 – 0	1.5 – 6.0	1.0 – 3.0	auto	150	2	017-509766
	RT 2	A	-25 – 15	5.0 – 18.0	6.0 – 20.0	auto	150	2	017-500866
	RT 8	A	-20 – 12	1.5 – 7.0	1.5 – 7.0	auto	145	2	017-506366
	RT 12	A	-5 – 10	1.0 – 3.5	1.0 – 3.0	auto	65	2	017-508966
	RT 23	A	5 – 22	1.1 – 3.5	1.0 – 3.0	auto	85	2	017-527866
	RT 15	A	8 – 32	1.6 – 8.0	1.6 – 8.0	auto	150	2	017-511566
	RT 24	A	15 – 34	1.4 – 4.0	1.4 – 3.5	auto	105	2	017-528566
	RT 140	C	15 – 45	1.8 – 8.0	2.5 – 11.0	auto	240	2	017-523666
	RT 102	D	25 – 90	2.4 – 10.0	3.5 – 20.0	auto	300	2	017-514766
	RT 34	B	-25 – 15	2.0 – 10.0	2.0 – 12.0	auto	100	–	017-511866
	RT 7	A	-25 – 15	2.0 – 10.0	2.5 – 14.0	auto	150	2	017-505366
RT 14	A	-5 – 30	2.0 – 8.0	2.0 – 10.0	auto	150	2	017-509966	
RT 101	A	25 – 90	2.4 – 10.0	3.5 – 20.0	auto	300	2	017-500366	
Partial ³⁾	RT 107	A	70 – 150	6.0 – 25.0	1.8 – 8.0	auto	215	2	017-513566

¹⁾ The sensor must be located colder than thermostat housing and capillary tube.

²⁾ The sensor can be located warmer or colder than thermostat housing.

³⁾ The sensor must be located warmer than thermostat housing and capillary tube.

⁴⁾ With built-in heating coil – reduces the thermal differential

Thermostats with adjustable dead zone

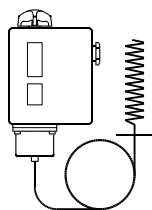

Charge	Type	Bulb type	Regulation range [°C]	Mechanical differential [K]	Neutral zone NZ		Max. bulb temp. [°C]	Capillary tube length [m]	Code no.
					At min. range setting [K]	At max. range setting [K]			
Vapour	RT 16L	B	0 – 38	1.5 – 0.7	1.5 – 5.0	0.7 – 1.9	100	–	017L002466
Adsorption	RT 8L	A	-20 – 12	1.5	1.5 – 4.4	1.5 – 4.9	145	2	017L003066
	RT 14L	A	-5 – 30	1.5	1.5 – 5.0	1.5 – 5.0	150	2	017L003466
	RT 140L	C	15 – 45	1.8 – 2.0	1.8 – 4.5	2.0 – 5.0	240	2	017L003166
	RT 101L	A	25 – 90	2.5 – 3.5	2.5 – 7.0	3.5 – 12.5	300	2	017L006266

Thermostat, Differential thermostat, type RT

Ordering Continued

Type of bulb / sensor

A	B	C	D
Cylindrical remote sensor	Room sensor	Duct sensor	Capillary tube sensor

Special versions

RT can be supplied with special switches.
See next page.

When ordering, please state:

1. Type
2. Code no. of standard unit
3. Code no. of special switch







Switches

Version	Symbol	Description	Contact rating	Reset	Code no.
Standard		Single-pole changeover switch with terminal board proof against leakage current. Fitted in all standard versions of type RT. Snap action changeover contacts.	Alternating current <i>Ohmic:</i> AC 1 = 10 A, 400 V <i>Inductive:</i> AC 3 = 4 A, 400 V AC 15 = 3 A, 400 V <i>Dir. current:</i> DC 13 = 12 W, 220 V	Auto	017-403066
Man. reset		For manual reset of unit after contact changeover on rising temperature. For units with reset facility.		Max.	017-404266
Man. reset		For manual reset of unit after contact changeover on falling temperature. For units with reset facility.		Min.	017-404166
Neutral zone		Single-pole changeover switch with dead zone and terminal board proof against leakage current.		–	Available only as a component part of RT controls with adjustable neutral zone

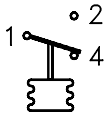
Thermostat, Differential thermostat, type RT

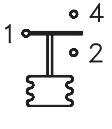
Ordering (continued)

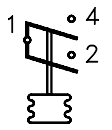
Switches

Version	Symbol	Description	Contact rating	Reset	Code no.
Standard	 SPDT	Single-pole changeover switch with gold plated (oxide-free) contact surfaces. Increases cut-in reliability on alarm and monitoring systems, etc. Snap action changeover contacts. Terminal board proof against leakage current.	Alternating current <i>Ohmic:</i> AC 1 = 10 A, 400 V	Auto	017-424066
Man. reset	 SPDT	Single-pole changeover switch with gold plated (oxide-free) contact surfaces. Increases cut-in reliability on alarm and monitoring systems, etc. Snap action changeover contacts. Terminal board proof against leakage current.		Max.	017-404866
Neutral zone	 SPDT	Single-pole changeover switch with dead zone and gold plated (oxide-free) contact surfaces. Increase cut-in reliability on alarm and monitoring systems, etc. Snap action changeover contacts. Terminal board proof against leakage current.		<i>Inductive:</i> AC 3 = 2 A, 400 V AC 15 = 1 A, 400 V <i>Dir. current:</i> DC 13 = 12 W, 220 V	–
Man. reset	 SPDT	Single-pole changeover switch with gold plated (oxide-free) contact surfaces. Increases cut-in reliability on alarm and monitoring systems, etc. Snap action changeover contacts. Terminal board proof against leakage current.	Alternating current <i>Ohmic:</i> AC 1 = 10 A, 400 V <i>Inductive:</i> AC 3 = 3 A, 400 V AC 15 = 2 A, 400 V <i>Dir. current:</i> DC 13 = 12 W, 220 V ¹⁾	Min.	017-404766
Cuts in two circuits simultaneously	 SPST	Single-pole changeover switch that cuts in two circuits simultaneously on rising temperature. Snap action changeover contacts. Terminal board proof against leakage current.		Max.	017-403466
With non-snap action change-over contacts	 SPDT	Single-pole changeover switch with non-snap action changeover contacts.		<i>Alternating or direct current</i> 25 VA, 24 V	–

¹⁾ If current is led through contacts 2 – 4, i.e. terminals 2 – 4 connected but not 1, max. permissible load is increased to 90 W, 220 V.

The switches are shown in the position they assume on falling temperature, i.e. after downward movement of the RT main spindle. The setting pointer of the control shows the scale value at which contact changeover occurs on falling temperature.

Spare parts and accessories,
see separate spare parts catalogue.

An exception is RT with switch, code no. **017-404266**, with max. reset where the setting pointer shows the scale value at which contact changeover occurs on rising temperature.

Thermostat, Differential thermostat, type RT

Design / Function

5. Setting knob
9. Regulation range scale
10. Loop terminal
11. Pg 13.5 screwed cable entry
12. Main spring
14. Terminals
15. Main spindle
16. Switch
17. Upper guide bush
18. Contact arm
19. Differential temperature setting nut
23. Bellows element
25. Fixing hole
26. Sensor (bulb) clip
28. Capillary tube
29. Sensor (bulb)
30. Sensor (bulb) pocket
31. Capillary tube gland
38. Earth terminal
44. Temperature setting spindle

Key sketch of RT thermostat

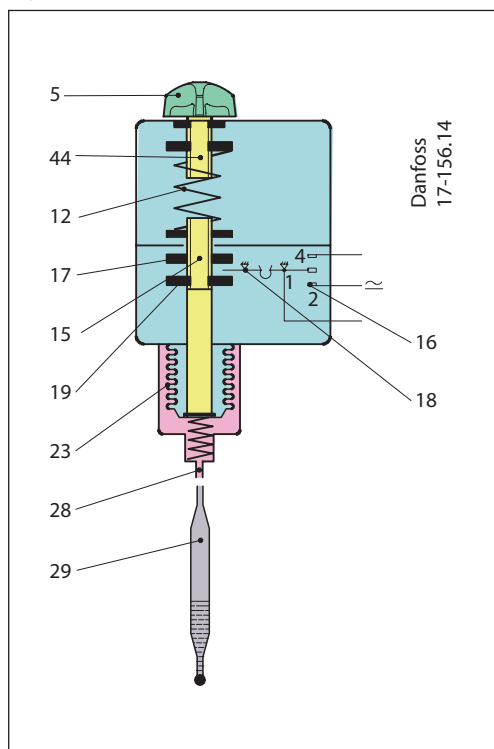

The thermostatic element consists of a sensor (29) capillary tube (28) and bellows element (23). The element contains a charge that reacts to temperature variations at the sensor so that the pressure on the moving bellows rises when temperature rises. By turning the setting knob (5) the main spring (12) can be set to balance the pressure in the element.

RT thermostat

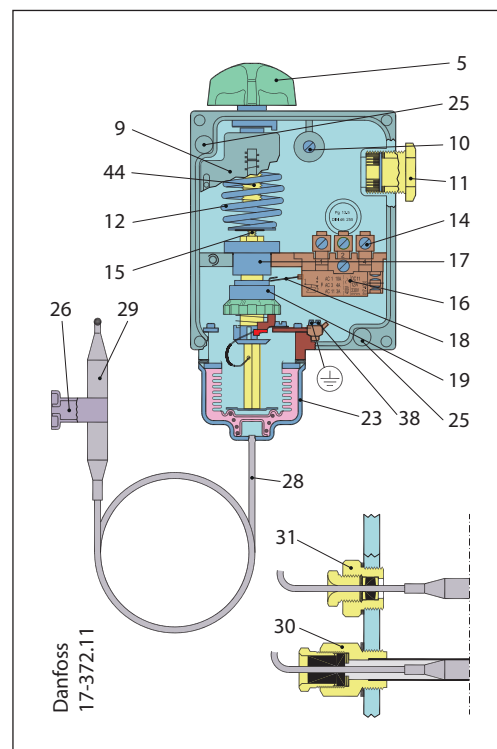

A rise in temperature at the sensor compresses the bellows and moves the main spindle (15) upwards until spring force and element pressure are in equilibrium. The main spindle (15) is fitted with a guide bush (17) and a differential setting nut (19) that together transfer the main spindle movement to the switch (16).

Thermostat, Differential thermostat, type RT

Design / Function (continued)

Key sketch RT L thermostat with neutral zone

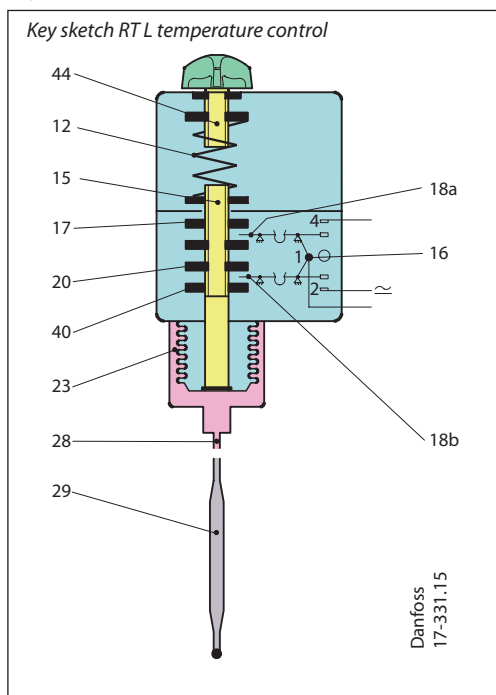

- 5. Setting knob
- 9. Regulation range scale
- 12. Main spring
- 15. Main spindle
- 16. Switch
- 17. Upper guide bush
- 18a and 18b. Contact arm
- 20. Lower guide bush
- 23. Bellows element
- 25. Fixing hole
- 28. Capillary tube
- 29. Sensor (bulb)
- 40. Neutral zone setting nut
- 44. Temperature setting spindle

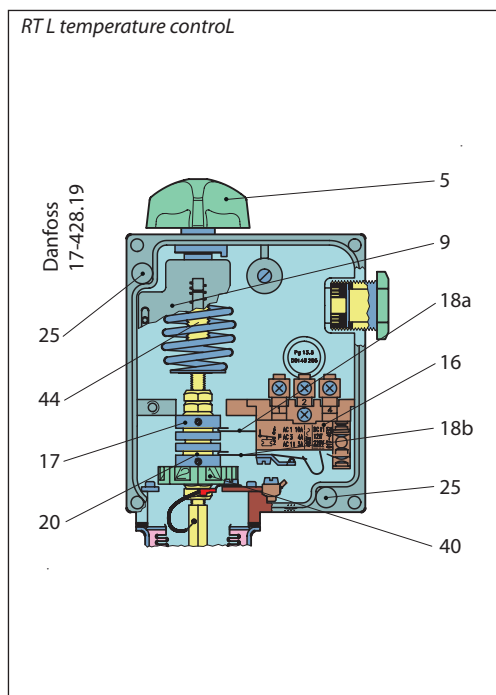

RT L thermostats are fitted with a switch with an adjustable neutral zone. This enables the units to be used for floating control.

The neutral zone switch contact arms (18a) and (18b) are operated by the spindle guide bushes (17) and (20).

The upper guide bush (17) is fixed while the lower guide bush (20) can be moved up or down by the setting nut (40). In this way the neutral zone can be varied between a minimum value (equal to the mechanical differential of the unit) and a maximum value (depending on the type of RT unit).

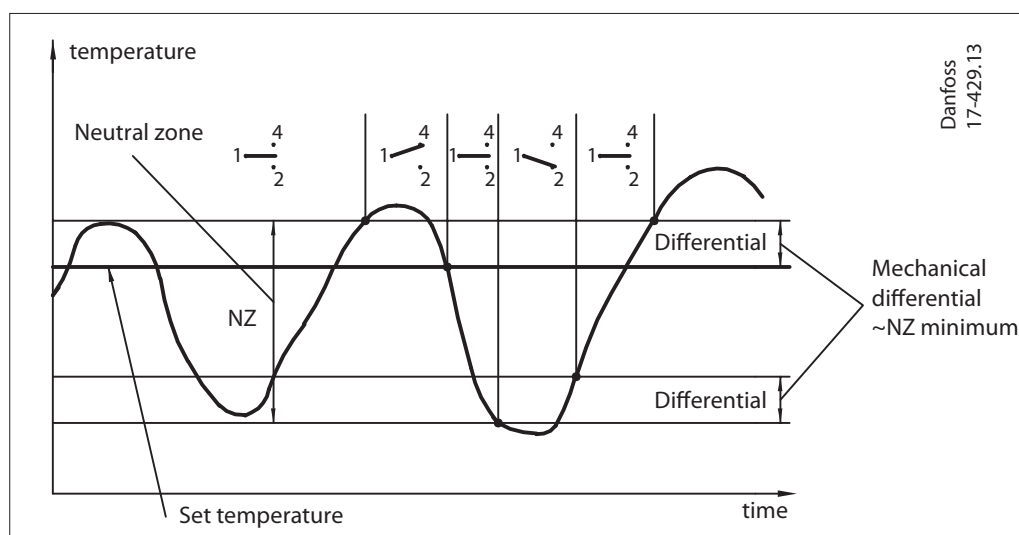

Terminology

Floating control

A form of delayed control where the correcting element (e.g. valve, damper, or similar) moves towards one extreme position at a rate independent of the magnitude of the error when the error exceeds a definite positive value, and towards the opposite extreme position when the error exceeds a definite negative value.

Hunting

Periodic variations of the controlled variable from the fixed reference.

Neutral zone

The interval between the make points of the two contacts.

Charges

1. Vapour charge

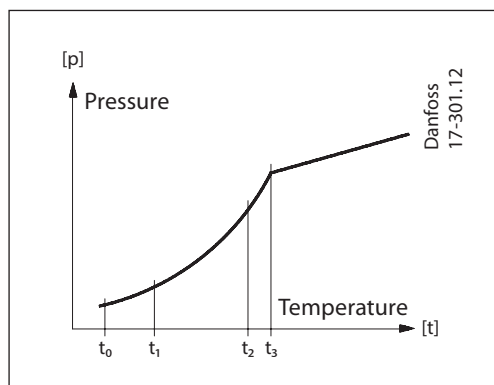

Here the interdependence between the pressure and temperature of saturated vapour is utilized, i.e. the element is charged with saturated vapour plus a small amount of liquid.

The charge is pressure-limited; a further increase in pressure after evaporation of all the liquid in the bulb, will only result in a small pressure increase in the element.

This principle can be utilized in thermostats for low temperature, etc., where evaporation must be able to take place from the free liquid surface in the bulb (within the operation range of the thermostat), and where at the same time, the bellows must be protected against deformation when kept at normal ambient temperatures. Since the pressure in the element depends on the temperature at the free liquid surface, the thermostat must always be placed so that the bulb is colder than the rest of the thermostatic element.

The evaporated liquid will recondense at the coldest point, i.e. the bulb. Thus, as intended, the bulb becomes the temperature-controlling element in the system.

Note:

When the bulb is coldest, the ambient temperature has no effect on regulating accuracy.

2. Adsorption charge

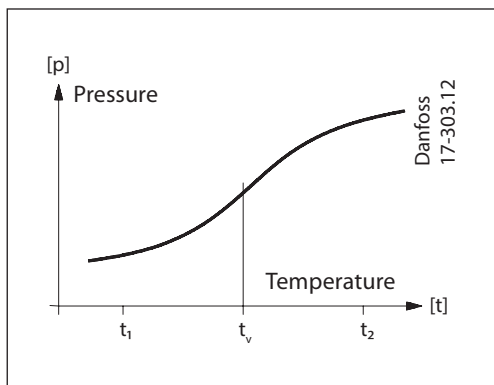

In this case the charge consists partly of a superheated gas and partly of a solid having a large adsorption surface.

The solid is concentrated in the bulb and it is therefore always the bulb that is the temperature-controlling part of the thermostatic element.

The bulb can thus be placed warmer or colder than the rest of the thermostatic element.

Such a charge is however to some extent sensitive to changes in the temperature of the bellows element and capillary tube.

Under normal conditions this is not important, but if the thermostat is used in extreme conditions, scale deviation will occur.

The scale can be corrected by using the graph and the table.

Scale correction = $Z \times a$.

Z can be found in the graph and "a" in the table.

Scale deviation factor

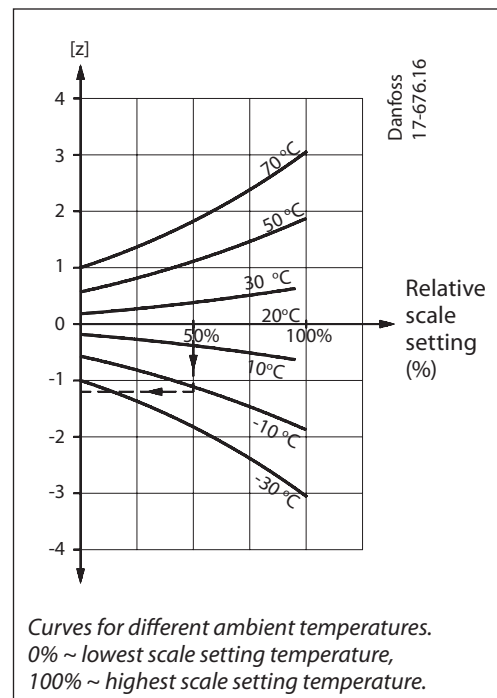

Curves for different ambient temperatures. 0% ~ lowest scale setting temperature, 100% ~ highest scale setting temperature.

Type	Range [°C]	Correction factor "a"
RT 2	-25 – 15	2.3
RT 7	-25 – 15	2.9
RT 8, RT 8L	-20 – 12	1.7
RT 12	-5 – 10	1.2
RT 14, RT 14L	-5 – 30	2.4
RT 15	8 – 32	1.2
RT 23	5 – 22	0.6
RT 24	15 – 34	0.8
RT 101, RT 102	25 – 90	5.0
RT 140, RT 140L	15 – 45	3.1

Thermostat, Differential thermostat, type RT

Charges (continued)

Example
Scale correction on an RT 14 (range -5 – 30 °C) at activating temperature 12 °C and ambient temperature -10 °C.
The scale temperature, 12 °C, lies approximately in the middle of the scale range, i.e. relative scale setting of 50%.
The factor Z can be found in the graph from 50% and the curve for -10 °C, i.e. approx. -1.2.

The correction factor “a” can be found in the table for an RT 14, i.e. 2.4.
The scale correction = $Z \times a = -1.2 \times 2.4 = -2.88$.
If activation at 12 °C for the same conditions is required, the thermostat must be set at $12 \times 2.88 = 9.12 \approx 9.1$.

3. Partial charge

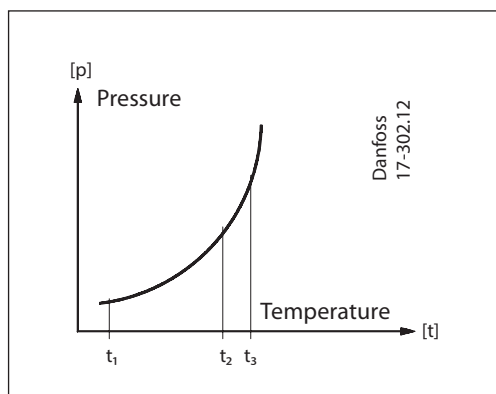

Partial charge is used in RT units having a range lying higher than ambient temperature.
As with the vapour charge, the partial charge utilizes the interdependence between the pressure and temperature of saturated vapour.

The partial charge is of such a volume that the bellows housing, capillary tube and a small part of the bulb are filled when the thermostat is in operation. The bulb is thus the warmest part of the system.
The liquid will condense in the remaining, coldest, part of the system but because of the volume of the charge the free liquid surface will always be in the bulb. In this way, the bulb becomes the temperature-controlling part of the system.

Note:

When the bulb is placed warmest, the ambient temperature has no effect on regulating accuracy.

Terminology

Regulation range
The temperature differential between LT and HT sensors within which the unit can be set to operate. Indicated on the thermostat scale.

Scale indication
The difference between the temperature on LT and HT sensors at the moment when the switch contacts change over as a result of the downward movement of the spindle.

Operating range
The temperature range of the LT sensor, within which the differential thermostat can operate.

Contact differential
The temperature rise on the HT sensor over the set temperature differential which causes the switch contacts to make or break.

Reference sensor
The sensor that is placed in the medium whose temperature is not affected by the function of the thermostat (HT or LT sensor).

Control sensor
The sensor that is placed in the medium whose temperature must be controlled (LT or HT sensor).

Setting of differential

The knob can be used to make a setting on the range scale for the lowest temperature at which the contact system must be activated (cut-out or cut-in).

The differential roller 19 must then be used to set the differential. The highest activating temperature at the sensor is equal to the activating temperature + the set differential.

Design / Function
RT differential thermostat

1. LT sensor (bulb)
2. Capillary tube
4. LT bellows element
5. Setting disc
9. Regulation range scale
10. Loop terminal
11. Pg 13.5 screwed cable entry
12. Main spring
14. Terminals
15. Main spindle
16. Switch
17. Upper guide bush
18. Contact arm
20. Lower guide bush
24. HT bellows element
25. Fixing hole
28. Capillary tube
32. HT sensor (bulb)
38. Earth terminal
39. Blow-out disc

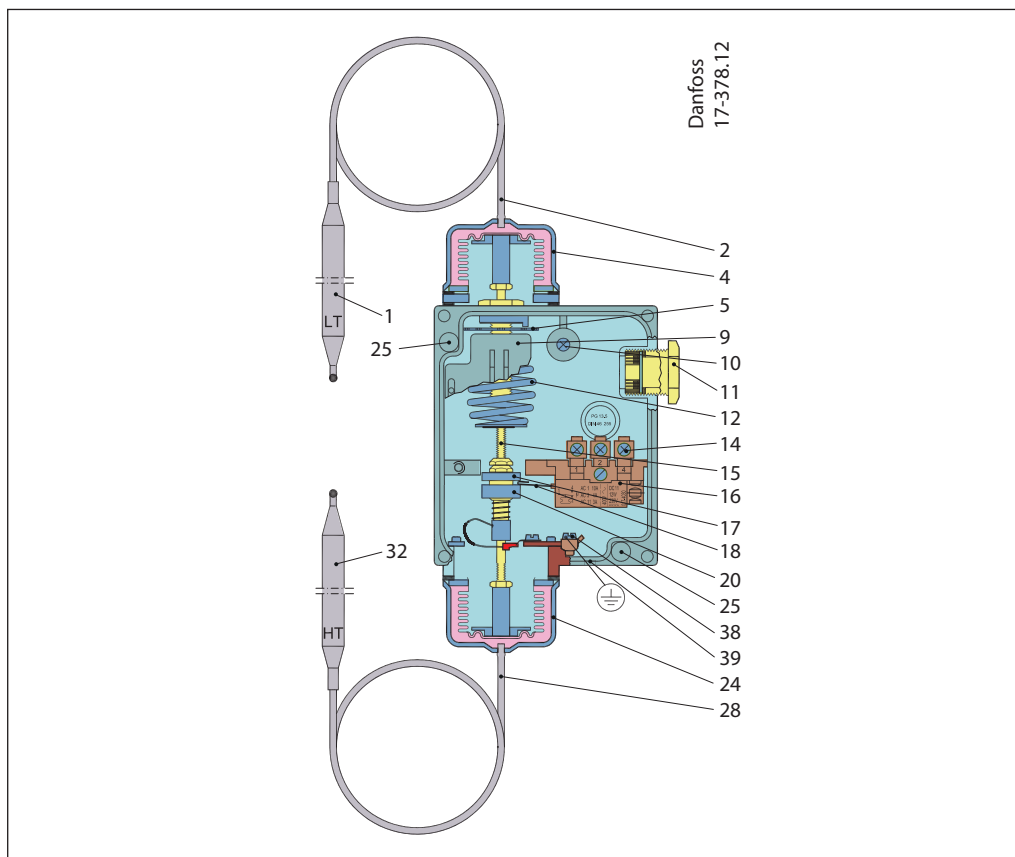

An RT differential thermostat contains a single-pole changeover switch that makes or breaks depending on the temperature difference between the two sensors of the unit. The RT 270 017D003166 is for use in process plant, ventilation plant, and refrigeration and heating plant where there is need to maintain a certain temperature differential, 0 – 15 °C, between two media. One sensor is used as a reference and the other as a control sensor. The temperature differential is the direct controlled variable.

Within the operating range the RT 270 can be set for different temperature differentials by the setting disc (5).

When the differential between LT and HT sensor temperature falls, the main spindle (15) moves downwards.

The contact arm (18) is moved downwards by the guide (17) so that contacts (1-4) break and contacts (1-2) make when the set temperature differential is reached.

The contacts changeover again when the temperature differential rises to the set value plus the fixed contact differential of approx. 2 °C.

The figure shows a cross-section of the RT 270.

The differential thermostat contains two bellows elements: the LT element whose sensor must be placed in the medium having the lowest temperature, and the HT element whose sensor must be placed in the medium having the highest temperature.

The main spring has a rectilinear characteristic.

Example

Set differential = 4 °C.

Switch breaks at 4 °C differential and remakes at 4+2=6 °C.

Thermostat, Differential thermostat, type RT

Nomograms for obtained differentials

RT 2

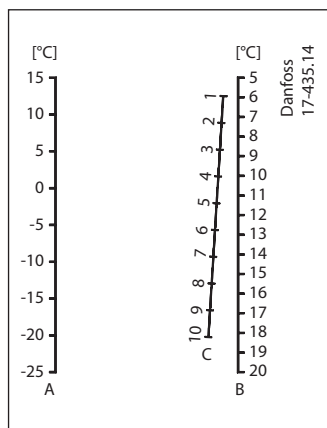

RT 3

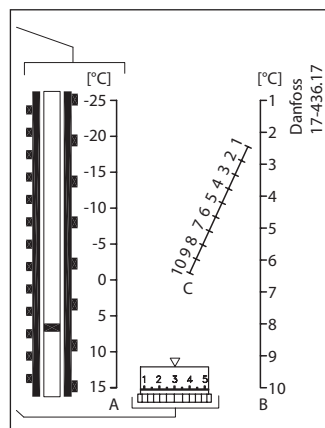

RT 4

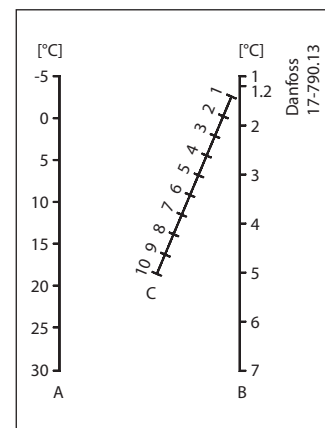

RT 7

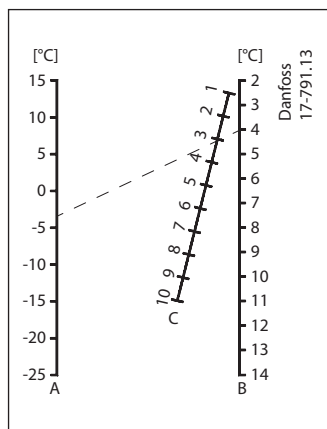

RT 9

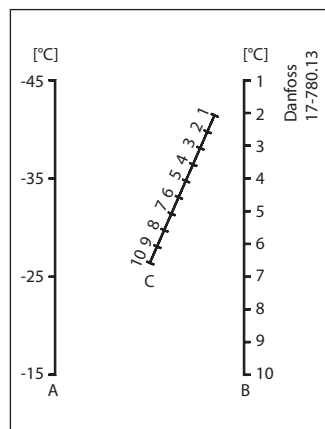

RT 10

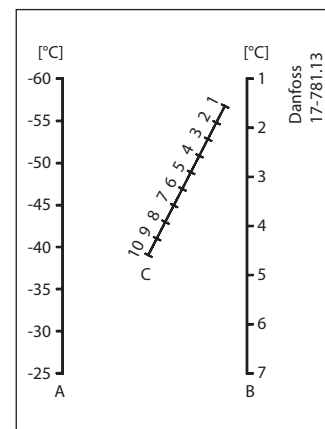

RT 11, RT 13

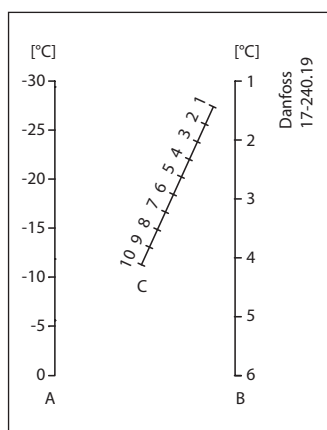

RT 12

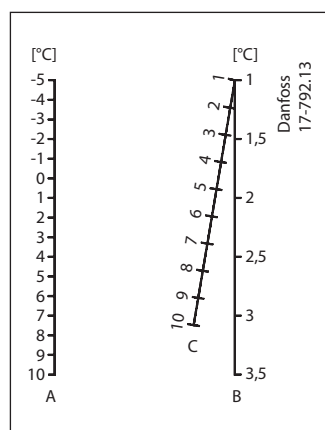

RT 24

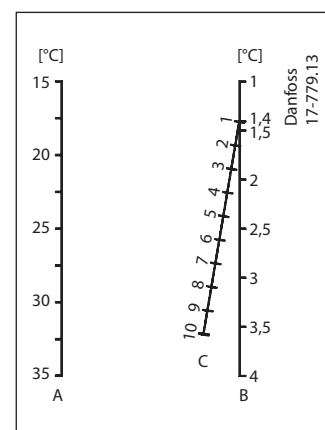

A = Range setting
 B = Obtained differential
 C = Differential setting

Thermostat, Differential thermostat, type RT

Nomograms for obtained differentials (continued)

RT 14

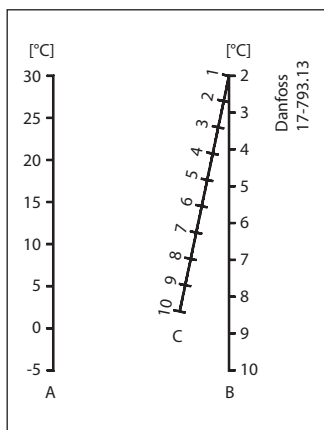

RT 17

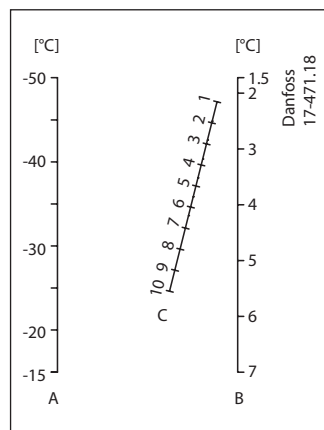

RT 23

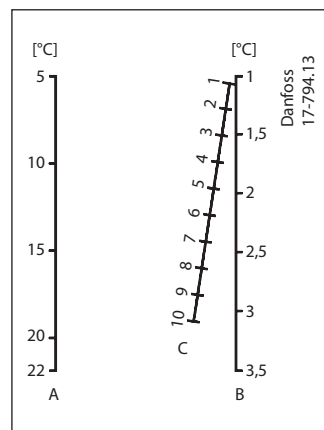

RT 34

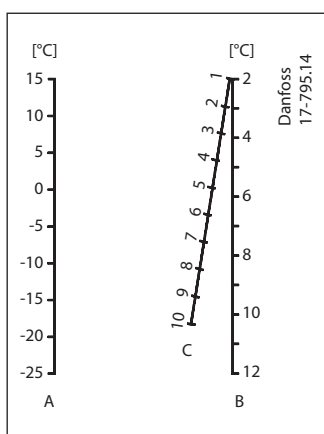

RT 101

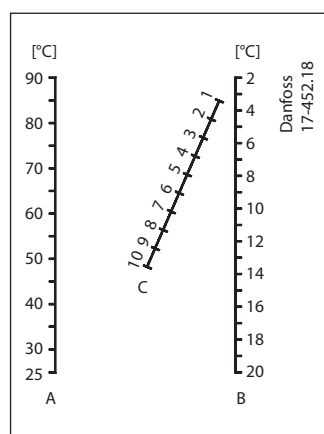

RT 107

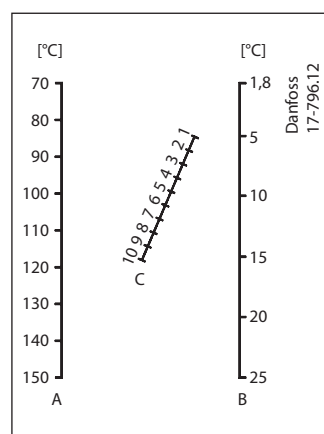

RT 140

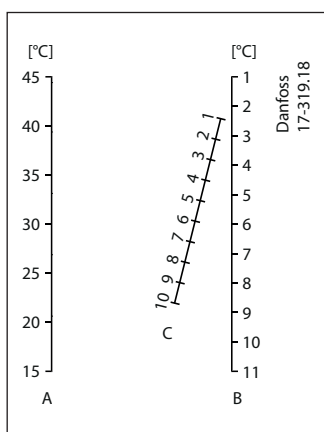

A = Range setting
 B = Obtained differential
 C = Differential setting

Thermostat, Differential thermostat, type RT

Dimensions and weights

RT thermostat housing

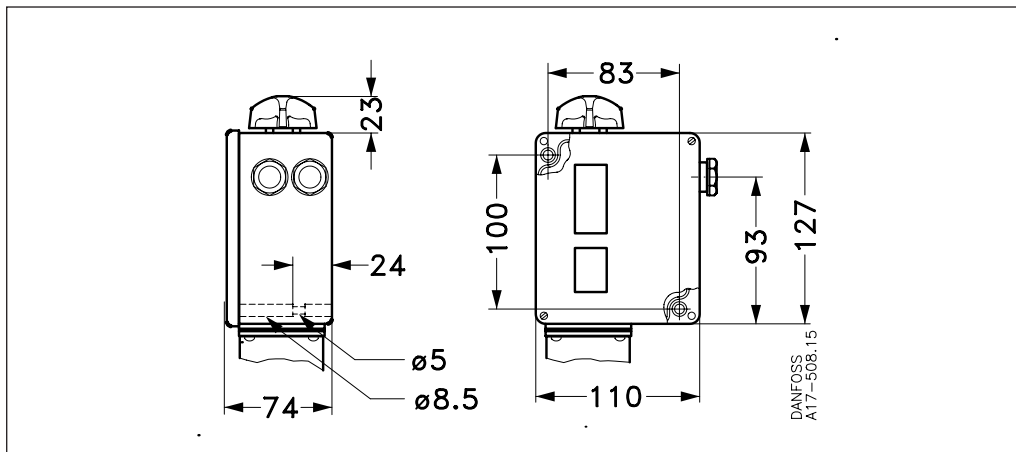

RT 4, RT 11, RT 16L, RT 17, RT 34

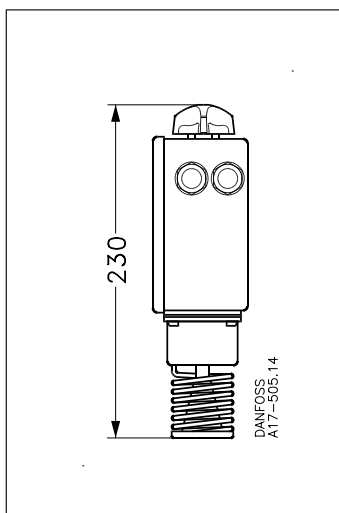

RT thermostat housing

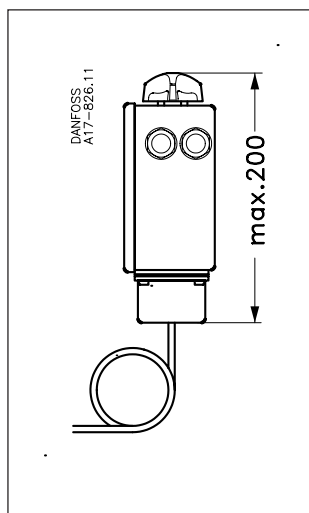

RT 140, RT 140L

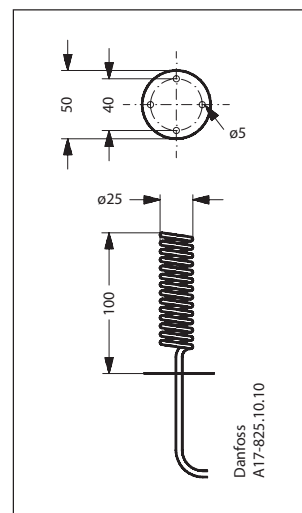

RT 2, RT 3, RT 7, RT 9,
RT 13, RT 101

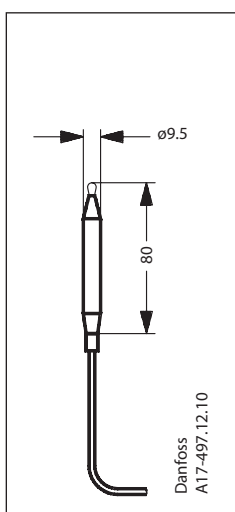

RT 8, RT 8L, RT 14,
RT 14L, RT 15, RT 107,
RT 270

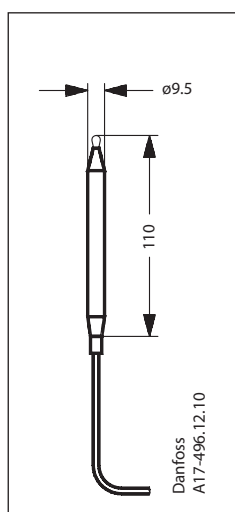

RT 12, RT 23, RT 24

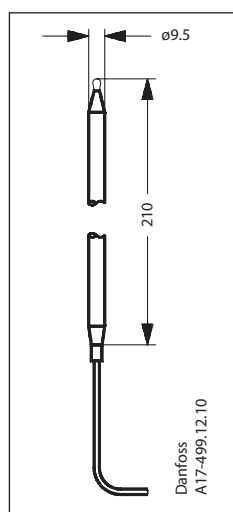

RT 102

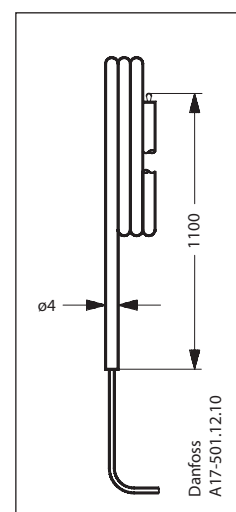

Net weight approx. 1 kg

Pressure switch, Differential pressure switch RT

Contents

	Page
Features	45
Approvals	46
Technical data	46
Materials in contact with the medium	47
Ordering	48
Design / Function	51
Terminology	54
Setting	54
Dimensions and weight	55

Pressure switch, Differential pressure switch RT



An RT pressure switch contains a pressure operated single-pole changeover contact, the position of which depends on the pressure in the inlet connection and the set scale value. The RT series includes pressure switches for general applications within industrial and marine refrigeration. The RT series also includes differential pressure switches, pressure switches for neutral zone regulation, and special pressure switches with gold-plated contact surfaces for PLC applications.

Features

- Versions with enclosure IP66
- Wide regulating range
- Wide range of units for industrial and marine applications
- Suitable for alternating and direct current (AC and DC)
- Interchangeable contact system
- Special versions for PLC applications
- Safety Integrity Level: SIL 2 according to IEC 61508

Pressure switch, Differential pressure switch, type RT

Approvals

RT 1	RT 1A	RT 1AL	RT 5A	RT 6W, RT 6B, RT 6S	RT 6AW, RT 6AB, RT 6AS	RT 30AW, RT 30AB, RT 30AS	RT 36B, RT 36S	RT 117	RT 117L	RT 200	RT 200L	RT 260A	RT 262A	
•				•		•		•		•				Germanischer Lloyd, GL
								•		•				Det Norske Veritas, DNV
								•		•				Bureau Veritas, BV
•	•							•		•		•	•	Registro Italiano Navale, RINA
•	•	•	•	•	•	•	•	•	•	•	•	•	•	Russian Maritime Register of Shipping, RMRS
•	•		•					•		•				Nippon Kaiji Kyokai, NKK
								•		•		•	•	Korean Register of Shipping, KRS
•	•	•	•	•	•	•	•	•	•	•	•	•	•	CE marked according to 60947-4, -5
				•	•	•	•							CE marked acc. to PED 97/23/EC category IV, safety equipment and EN 12263
•	•	•	•	•	•	•	•	•	•	•	•	•	•	China Compulsory Certificate, CCC

Technical data

Cable connection	2 × Pg 13.5 Cable diameter 6 – 14 mm
Enclosure	IP66 to EN 60529 / IEC 529, except for versions with ext. reset which are IP54
Ambient temperature	-50 – 70 °C for pressure control housing
Switches	See "Ordering, switches" (below)
Solid / stranded	0.2 – 2.5 mm ²
Flexible, without ferrules	0.2 – 2.5 mm ²
Flexible, with ferrules	0.2 – 1.5 mm ²
Tightening torque	max. 1.5 Nm
Rated impulse voltage	4 kV
Pollution degree	3
Short circuit protection, fuse	10 Amp
Insulation	400 V

Pressure switch, Differential pressure switch, type RT
Materials in contact with the medium

Type	Bellows	Material	W. no.	To EN	Comments
RT 260AL, RT 262AL, RT 263AL, RT 265A, RT 5A, RT 5AL, RT 260A	017-7253	Steel	1.0338	10139	Nickel-plated
	017-7254	Steel	1.0401	10277-2	Nickel-plated
	017-7258	Stainless Steel	1.4306	10088-2	—
	017-7260	—	—	—	—
	017-7252	—	—	—	—
	017-7274	—	—	—	—
	017-7253	—	—	—	—
	017-7258	—	—	—	—
	017-7269	—	—	—	—
	017-7270	—	—	—	—
	—	Aluminium ¹⁾	3.0255	573-3	—
—	Steel ¹⁾	1.0402	10250-2	Zn-plated	
RT 1	017-7256	Steel	1.0338	10139	Nickel-plated, Tin-plated
	—	Steel	1.0718	10227-3	Nickel-plated
	—	Stainless Steel	1.4306	10088-2	—
	—	Steel	Spring wire type DH	10270-1	Zn-plated
RT 200, RT 200L	017-7275	Stainless Steel	1.4306	10088-2	—
	—	Stainless Steel	1.4568	10270-3	—
	—	Brass	2.0321	1652	—
	—	Brass	2.0402	12165	—
RT 6B, RT 6S, RT 6W, RT 6AB, RT 6AS, RT 6AW	017-7281	Steel	1.0332	10111	Nickel-plated
	017-7282	Steel	1.0338	10139	Nickel-plated
	017-7283	Steel	1.0718	10227-3	Nickel-plated
	—	Stainless Steel	1.4306	10088-2	—
	—	Aluminium ¹⁾	3.0255	573-3	—
	—	Steel ¹⁾	1.0402	10250-2	Zn-plated
RT 1A, RT 1AL	017-7255	Steel	1.0338	10139	Nickel-plated, Tin-plated
	017-7259	Steel	1.0401	10277-2	Nickel-plated
	—	Stainless Steel	1.4306	10088-2	—
	—	Steel	Spring wire type DH	10270-1	Zn-plated
	—	Aluminium ¹⁾	3.0255	573-3	—
	—	Steel ¹⁾	1.0402	10250-2	Zn-plated
RT 262A	017-7254	Steel	1.0338	10139	Nickel-plated
	017-7268	Steel	1.0401	10277-2	Nickel-plated
	017-7288	Stainless Steel	1.4305	10088-3	—
	—	Stainless Steel	1.4306	10088-2	—
	—	Aluminium ¹⁾	3.0255	573-3	—
	—	Steel ¹⁾	1.0402	10250-2	Zn-plated
RT 117, RT 117L	017-7279	Stainless Steel	1.4306	10088-2	—
	—	Stainless Steel	1.4568	10270-3	—
	—	Brass	2.0321	1652	—
	—	Brass	2.0401	12164	—
	—	Brass	2.0402	12165	—
RT 36B, RT 36S, RT 30AW, RT 30AB, RT 30AS	017-7284	Steel	1.0332	10111	Nickel-plated
	017-7286	Steel	1.0338	10139	Nickel-plated
	017-7283	Steel	1.0718	10227-3	Nickel-plated
	017-7286	Stainless Steel	1.4305	10088-3	—
	—	Stainless Steel	1.4306	10088-2	—
	—	Stainless Steel	1.4568	10270-3	—

¹⁾ Only in types with connection G 3/8 A + weld nipple ø 6.5/10 mm

Pressure switch, Differential pressure switch, type RT

Ordering

For R22, R134a, R404A, R407A, R407C, R407F, R422B, R422D

For complete list of approved refrigerants, visit www.products.danfoss.com and search for individual code numbers, where refrigerants are listed as part of technical data.

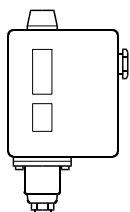

Pressure	Type	Regulation range [bar]	Differential Δp [bar]	Reset	Max. working pressure PS [bar]	Max. test pressure P _e [bar]	Code no.	
							Connection	
							¼ in flare	G 3/8 A ¹⁾
Low	RT 1	-0.8 – 5	0.5 – 1.6	Auto.	22	25	017-524566	–
		-0.8 – 5	0.5	Man. (Min.)	22	25	017-524666	–
	RT 200	0.2 – 6	0.25 – 1.2	Auto	22	25	–	017-523766
High	RT 117	10 – 30	1 – 4	Auto	42	47	–	017-529566

¹⁾ BSP ext. thread, ISO 228-1.

Safety – Pressure switches for

R22, R134a, R404A, R407A, R407C, R407F, R422B, R422D, R507A, R717 *)

For complete list of approved refrigerants, visit www.products.danfoss.com and search for individual code numbers, where refrigerants are listed as part of technical data.

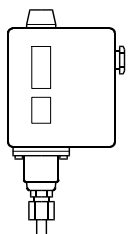

Pressure	Type	Regulation range [bar]	Differential Δp [bar]	Reset	Max. working Pressure PS [bar]	Max. test pressure P _e [bar]	Code no.	
							Connection	
							Cutting ring ø6 mm	G 3/8 A ¹⁾ + weld nipple ø6.5/10 mm
Low	RT 1A	-0.8 – 5	0.5 – 1.6	Auto	22	25	017-501966	017-500166
		-0.8 – 5	0.5	Man. (Min.)	22	25	017-502766	017-500266
		-0.8 – 5	1.3 – 2.4	Auto	22	25	–	017-500766
High	RT 5A	4 – 17	1.2 – 4	Auto	22	25	017-505266	017-504666
		4 – 17	1.3	Man. (Max.)	22	25	017-506166	017-504766

¹⁾ BSP ext. thread, ISO 228-1.

*) Only for RT 1A, RT 5A.

Safety pressure switches with EN 12263 approval and CE marked acc. PED (Pressure Equipment Directive) *)

R22, R134a, R404A, R407A, R407C, R407F, R422B, R422D, R507A, R717 **)

For complete list of approved refrigerants, visit www.products.danfoss.com and search for individual code numbers, where refrigerants are listed as part of technical data.

Pressure	Type	Regulation range [bar]	Differential (fixed) Δp [bar]	Reset [bar]	Max. working pressure PS [bar]	Max. test pressure P _e [bar]	Code no.			
							Connection			
							¼ in flare	Cutting ring ø6 mm	G 3/8 A ¹⁾ + weld nipple ø6.5/10 mm	G ½ A ¹⁾
High	RT 6W	5 – 25	3.0	Auto	34 ³⁾	38	017-503166	–	–	–
	RT 6B	10 – 28	1.0 ⁴⁾	Man. (Max.)	34 ³⁾	38	017-503466	–	–	–
	RT 6S	10 – 28	1.0 ⁴⁾	Man. (Max.)	34 ³⁾	38	017-507566	–	–	–
High	RT 30AW ²⁾	1 – 10	0.8	Auto	22	25	–	–	–	017-518766
	RT 30AB ²⁾	1 – 10	0.6 ⁴⁾	Man. (Max.)	22	25	–	–	–	017-518866
	RT 30AS ²⁾	1 – 10	0.4 ⁴⁾	Man. (Max.)	22	25	–	–	–	017-518966
High	RT 6AW	5 – 25	3.0	Auto	34 ³⁾	38	–	017-513166	017-503266	–
	RT 6AB	10 – 28	1.5 ⁴⁾	Man. (Max.)	34 ³⁾	38	–	017-513366	017-503566	–
	RT 6AS	10 – 28	1.5 ⁴⁾	Man. (Max.)	34 ³⁾	38	–	017-514666	017-507666	–

*) Meets the requirements in VBG 20 on safety equipment and excess pressures.

W=Wächter (pressure control).

B= Begrenzer (pressure control with external reset).

S= Sicherheitsdruckbegrenzer

(pressure control with internal reset).

A rupture in the bellows system of the unit will cause the compressor to stop.

**) Only for RT 6AW, RT 6AB, RT 6AS, RT 30AW, RT 30AB, RT 30AS.

¹⁾BSP ext. thread, ISO 228-1.

²⁾Approved for PED also acc. to EN12953-9 and EN12922-11.

³⁾Max. working pressure acc. to PED is limited to 28 bar.

⁴⁾Max.

Pressure switch, Differential pressure switch, type RT

Ordering (continued)

Pressure switches with adjustable neutral zone for R22, R134a, R404A, R407A, R407C, R407F, R507A, R717 *)

For complete list of approved refrigerants, visit www.products.danfoss.com and search for individual code numbers, where refrigerants are listed as part of technical data.

Pressure	Type	Regulation range [bar]	Differential Δp [bar]	Adjustable neutral zone NZ Δp [bar]	Max. working Pressure PS [bar]	Max. test pressure P_e [bar]	Code no.	
							Connection	
							Cutting ring $\varnothing 6$ mm	G 3/8 A ¹⁾ + weld nipple $\varnothing 6.5/10$ mm
Low	RT 1AL	-0.8 – 5	0.2	0.2 – 0.9	22	25	017L001666	017L003366
	RT 200L	0.2 – 6	0.25	0.25 – 0.7	22	25	–	017L003266 ²⁾
High	RT 5AL	4 – 17	0.35	0.35 – 1.4	22	25	017L001766 ²⁾	017L004066
	RT 117L	10 – 30	1.0	1 – 3.0	42	47	–	017L004266 ²⁾

¹⁾ BSP ext. thread, ISO 228-1.

²⁾ Without nipple.

^{*}) Only for RT 1AL, RT 5AL.

Differential pressure switches for

R22, R134a, R404A, R407A, R407C, R407F, R422B, R422D, R507A, R717

For complete list of approved refrigerants, visit www.products.danfoss.com and search for individual code numbers, where refrigerants are listed as part of technical data.

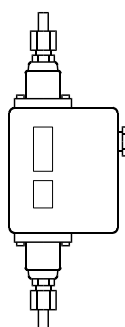

Type	Regulation range [bar]	Differential Δp [bar]	Operating range for LP bellows [bar]	Max. working Pressure PS [bar]	Max. test pressure P_e [bar]	Code no.	
						Connection	
						Cutting ring $\varnothing 6$ mm	G 3/8 A ¹⁾ + weld nipple $\varnothing 6.5/10$ mm
RT 260A	0.5 – 4	0.3	-1 – 18	22	25	017D001466	017D002166
	0.5 – 4	0.3	-1 – 18	22	25	–	017D002266 ²⁾
	0.5 – 6	0.5	-1 – 36	42	47	017D001566 ⁴⁾	017D002366
	1.5 – 11	0.5	-1 – 31	42	47	017D001666	017D002466
RT 262A	0.1 – 1.5	0.1	-1 – 9	11	13	017D001366	017D002566
RT 265A ³⁾	1 – 6	0.5	-1 – 36	42	47	–	017D007266

¹⁾ BSP ext thread, ISO 228-1.

³⁾ Filter monitor: Alarm $\Delta p = 0.8$ bar, cut-out $\Delta p = 1$ bar (factory setting).

²⁾ Man. (Max.) reset.

⁴⁾ With 3 m capillary tube.

Differential pressure switches with adjustable neutral zone for

R22, R134a, R404A, R407A, R407C, R407F, R422B, R422D, R507A, R717

For complete list of approved refrigerants, visit www.products.danfoss.com and search for individual code numbers, where refrigerants are listed as part of technical data.







Type	Regulation range [bar]	Differential Δp [bar]	Adjustable neutral zone NZ [bar]	Operating range for LP bellows [bar]	Max. working pressure PS [bar]	Max. test pressure P_e [bar]	Code no.
							Connection
							G 3/8 A ¹⁾ + weld nipple $\varnothing 6.5/10$ mm
RT 262 AL	0.1 – 1.5	0.1	0.1 – 0.33	-1 – 9	11	13	017D004366

¹⁾ BSP ext thread, ISO 228-1.

Pressure switch, Differential pressure switch, type RT

Ordering (continued)

Switches¹⁾

Contact system versions	Contact system	Description	Contact load	Code no.
With automatic reset	 SPDT	Single-pole changeover switch with terminal board proof against leakage current. Fitted in all standard versions of type RT. Snap action changeover contacts.	Alternating current ²⁾ Ohmic: AC 1 = 10 A, 400 V Inductive: AC 3 = 4 A, 400 V AC 15 = 3 A, 400 V Direct current DC 13 = 12 W, 220 V	017-403066
With manual (max.) reset	 SPDT	For manual reset of unit after contact changeover on rising pressure. For HP units prepared for reset facility.		017-404266
With manual (min.) reset	 SPDT	For manual reset of unit after contact changeover on falling pressure. For LP-units prepared for reset facility.		017-404166
With automatic reset, gold-plated	 SPDT	Single-pole changeover switch with gold plated (oxide-free) contact surfaces. Increases cut-in reliability on alarm and monitoring systems, etc. Snap action changeover contacts. Terminal board proof against leakage current.	Alternating current ²⁾ Ohmic: AC 1 = 10 A, 400 V Inductive: AC 3 = 2 A, 400 V AC 15 = 1 A, 400 V Direct current DC 13 = 12 W, 220 V	017-424066
Cuts in two circuits simultaneously	 SPST	Single-pole changeover switch that cuts in two circuits simultaneously on rising pressure. Snap action changeover contacts. Terminal board proof against leakage current.	Alternating current ²⁾ Ohmic: AC 1 = 10 A, 400 V Inductive: AC 3 = 3 A, 400 V AC 15 = 2 A, 400 V Direct current DC 13 = 12 W, 220 V ³⁾	017-403466
With non-snap action changeover contacts	 SPDT	Single-pole changeover switch with non-snap action changeover contacts.	Alternating or direct current 25 VA, 24 V	017-018166

¹⁾ RT pressure switches meet the conditions of EN 60947-2-9.

²⁾ Max. starting current (L.R.) = 7 × AC 3.

³⁾ If current is led through the contacts 2 and 4, i.e. terminals 2 and 4 connected but not terminal 1, the max. permissible load is increased by 90 W, 220V.

The switches are shown in the position they assume on falling pressure, i.e. after downward movement of the RT main spindle.

The setting pointer of the switch shows the scale value at which contact changeover occurs on falling pressure.

An exception is RT with switch code no. 017-404266 with Man. reset, where the setting pointer shows the scale value at which contact changeover occurs on rising pressure.

Special versions

RT can be supplied with special switches as follows.

When ordering, please state:

1. Type
2. Code no. of standard unit
3. Code no. of special switch

Pressure switch, Differential pressure switch, type RT

Design / Function

- 5. Setting knob
- 9. Regulation range scale
- 10. Loop terminal
- 11. Pg 13.5 screwed cable entry
- 12. Main spring
- 14. Terminals
- 15. Main spindle
- 16. Switch
- 17. Guide bush
- 18. Contact arm
- 19. Differential setting nut
- 23. Bellows element
- 25. Fixing hole
- 27. Connection
- 38. Earth terminal
- 39. Blow-out disc
- 44. Pressure setting spindle

Pressure switch, type RT

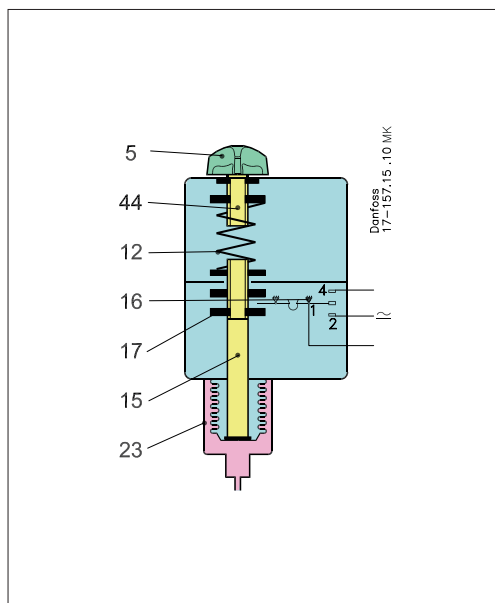

Pressure switch, type RT

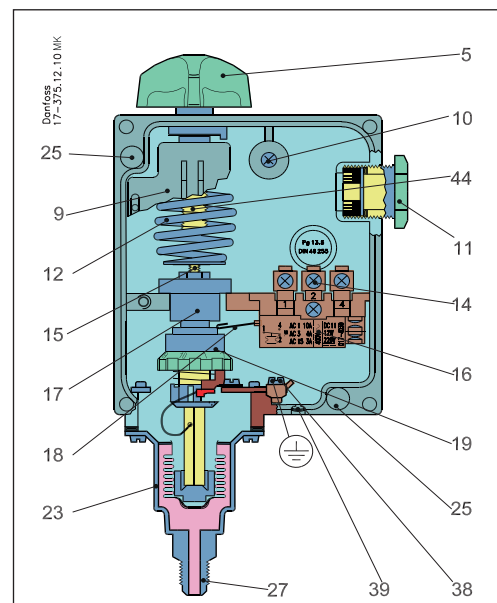

The bellows in the RT pressure switch is connected to the low or high pressure side of the controlled system via the connection.

By turning the setting knob (5) the main spring (12) can be set to balance the pressure in the bellows.

A rise in pressure compresses the bellows and moves the main spindle (15) upwards until spring and bellows pressure are in equilibrium. The main spindle (15) is fitted with a guide bush (17) and a differential pressure setting nut (19) that together transfer the main spindle movement to the switch (16).

The RT 6W, RT 6B, RT 6S, RT 6AW, RT 6AB, RT 6AS, RT 30AW, RT 30AB, RT 30AS, RT 36B, RT 36S are equipped with a double bellows (an outer bellows and a regulating bellows).

These units have been tested and approved by TÜV (Technischer Überwachungs Verein, Germany) according to EN 12263.

General for EN 12263 approved units.

1. The units are equipped with a double bellows system. When pressure in the plant exceeds the set value, the unit will automatically stop the plant. The double bellows system prevents loss of system charge in the event of bellows rupture.
2. Versions with designation W or AW cut again automatically when the pressure has fallen to the set value minus the differential.

3. Versions with designation B or AB are cut manually with the external reset button. This is possible when the pressure has fallen to the set value minus differential.
4. Versions with designation S or AS can be cut in manually with the internal reset arm when the pressure has fallen to the set value minus differential.

As laid down by EN 12263 requirements, if a rupture occurs in the regulating bellows of the unit, the refrigerating system compressor will be stopped and can only be restarted when the pressure control has been replaced.

A rupture in the outer bellows will cause the cut-out pressure of RT 36 to fall 2.5 bar, and the cut-out pressure of RT 6 and RT 30 to fall 4.5 bar under the set value. This means that the unit cuts out at normal condensing pressure and thus provides a fail-safe function.

All RT pressure switches, including those which are EN 12263 approved, operate independently of changes in the ambient temperature around the control housing. Therefore the set cut-out pressure and differential are held constant provided the permissible ambient temperatures are not exceeded.

Pressure switch, Differential pressure switch, type RT

Design / Function
(continued)

Pressure switch with adjustable neutral zone, type RT L

Pressure switch, type RT L

- 5. Setting knob
- 9. Regulation range scale
- 11. Pg 13.5 screwed cable entry
- 12. Main spring
- 15. Main spindle
- 16. Switch
- 17. Upper guide bush
- 18. 18a, 18b. Contact arm
- 20. Lower guide bush
- 23. Bellows element
- 25. Fixing hole
- 27. Connection
- 38. Earth terminal
- 39. Blow-out disc
- 40. Neutral zone setting nut
- 44. Pressure setting spindle

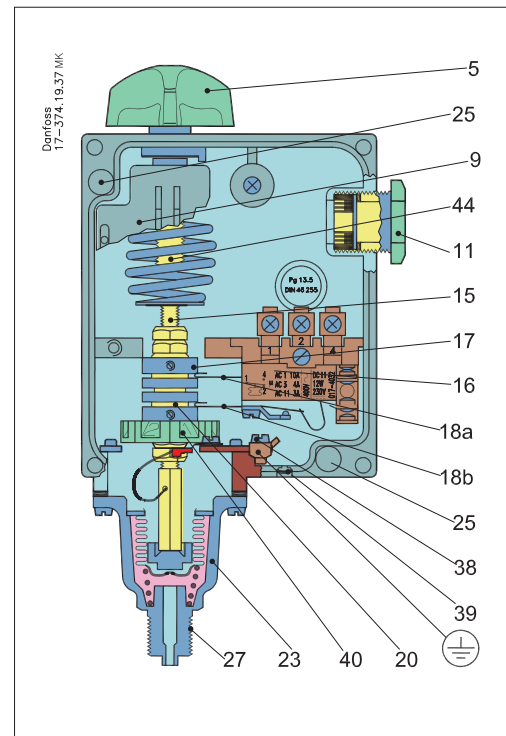
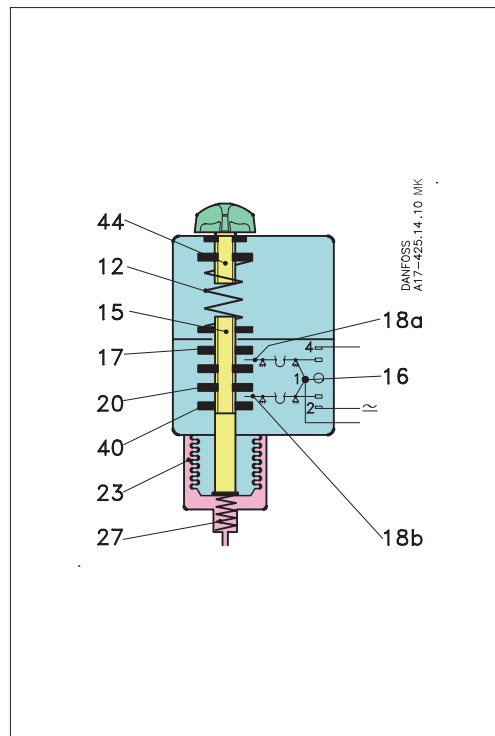

RT L pressure switches are fitted with a switch with an adjustable neutral zone. This enables the units to be used for floating control. The neutral zone switch contact arms (18a) and (18b) are operated by the spindle guide bushes (17) and (20).

The upper guide bush (17) is fixed while the lower guide bush (20) can be moved up or down by the setting nut (40). In this way the neutral zone can be varied between a minimum value (equal to the mechanical differential of the unit) and a maximum value (depending on the type of RT unit).

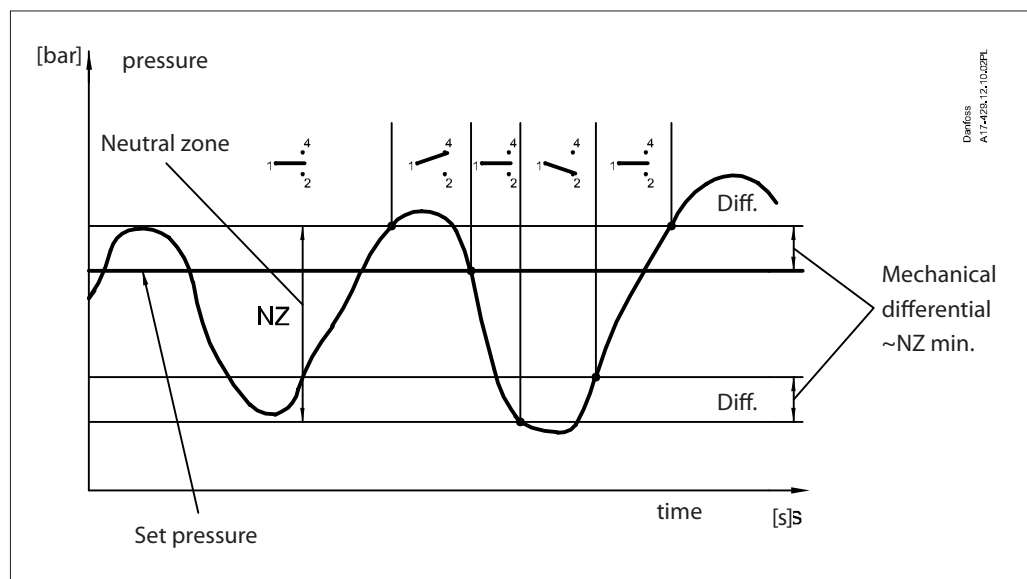

Pressure switch, Differential pressure switch, type RT

Design / Function (continued)

Differential pressure switch, type RT

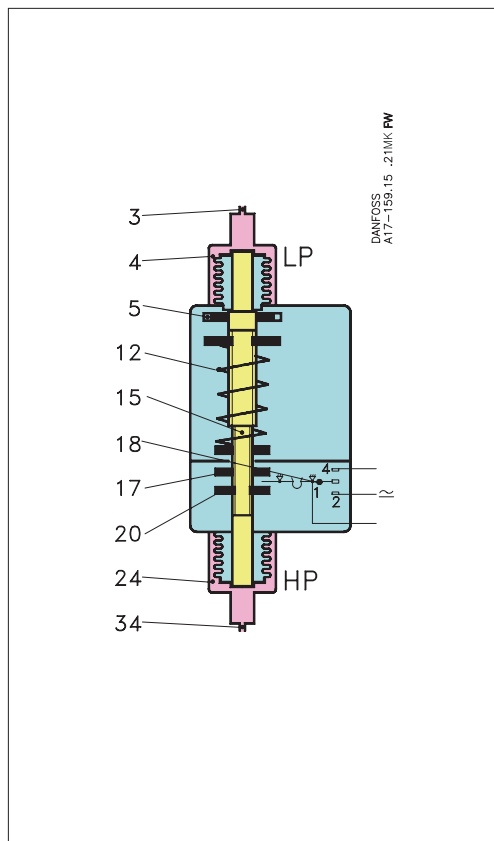

- 3. LP connection
- 4. LP bellows element
- 5. Setting disc
- 9. Regulation range scale
- 10. Coil clamp
- 11. Pg 13.5 screwed cable entry
- 12. Main spring
- 14. Terminals
- 15. Main spindle
- 16. Switch
- 17. Upper guide bush
- 18. Contact arm
- 20. Lower guide bush
- 24. HP bellows element
- 25. Fixing hole
- 34. HP connection
- 38. Earth terminal
- 39. Blow-out disc

Differential pressure switch, type RT

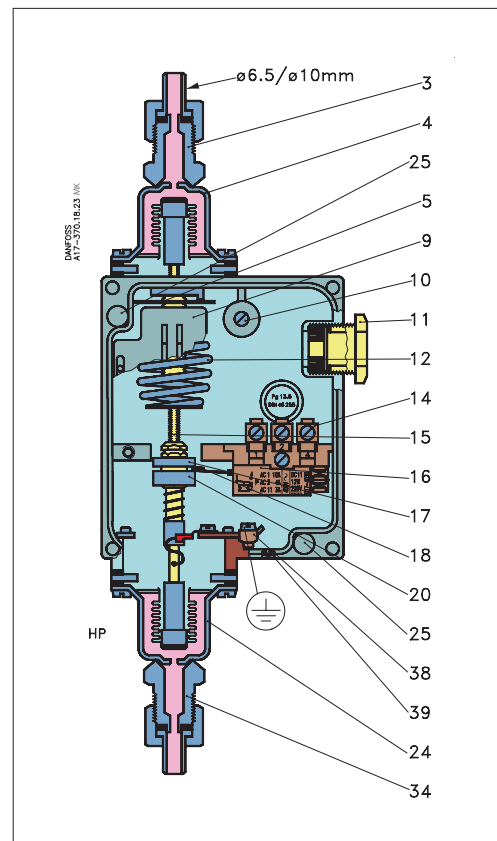

An RT differential pressure switch contains a single-pole changeover switch that makes or breaks depending on the pressure differential between two counteracting bellows elements (LP and HP).

Differential pressure switches are used primarily as protection against too low a differential pressure across liquid circulation pumps. A secondary application is the safeguarding of lubricating oil pressure in refrigeration compressors.

The function of the pressure switch is conditional only on the differential pressure, i.e. the difference in pressure between the two counteracting bellows, whereas it is independent of the absolute pressure on both bellows.

The bellows (4) and (24) are respectively connected to the LP port (lowest pressure) and the HP port (highest pressure).

The main spring (12) can be set for different differential pressures by the setting disc (5). If the differential pressure between highest and lowest pressures falls, the spindle (15) moves downwards and via the upper guide bush (17), actuates the switch contact arm (18). The reverse function occurs if the differential pressure rises.

Pressure switch, Differential pressure switch, type RT

Terminology

Floating control

A form of delayed control where the correcting element (e.g. valve, damper, or similar) moves towards one extreme position at a rate independent of the magnitude of the error when the error exceeds a definite positive value, and towards the opposite extreme position when the error exceeds a definite negative value.

Hunting

Periodic variations of the controlled variable from the fixed reference.

Neutral zone

The interval between the make points of the two contacts.

“Snap function”

A certain contact force is maintained until the irrevocable “snap” is initiated. The time during which the contact force approaches zero is thus limited to a very few milliseconds. Therefore contact bounce cannot occur as a result of, for example, slight vibrations, before the cut-out point.

Contact systems with “Snap function”

will change over even when micro-welds are created between the contacts during cut-in. A very high force is created during cut-out to separate the contacts. This force immediately shears off all the welds. Thus the cut-out point of the unit remains very accurate and completely independent of the magnitude of the current load.

Setting

RT with automatic reset – LP

The knob is used to set the lowest pressure at which the contact system must be activated (cut-out or cut-in).

This value can be read on the main scale of the unit.

The differential roller must be used to set the differential.

Highest activating pressure = lowest activating pressure + set differential.

RT with manual reset – LP

RT pressure switches RT 1 and RT 1A are obtainable in versions with min. reset. When the pressure falls to the setting value the pressure control cuts out.

Manual reset becomes possible when the pressure in the bellows system has risen to a value corresponding to the set value + the differential.

On falling pressure the follower activates the contact system arm and the contact changes over.

The scale is calibrated so that the scale value corresponds to contact changeover on falling pressure.

RT with automatic reset – HP

The knob can be used to set the lowest pressure at which the contact system must be activated (cut-out or cut-in).

This value can be read on the main scale of the unit.

The differential must be set with the differential roller. Highest activating pressure = lowest activating pressure + set differential.

RT with manual reset – HP

Pressure switch RT 5A is obtainable with max. reset. When the pressure has risen to the set value the pressure control cuts out.

Manual reset only becomes possible when the pressure has fallen to a value corresponding to the set pressure minus the differential.

The differential roller is then used as a follower. On rising pressure the differential roller activates the contact system arm and the contact changes over.

The scale is calibrated so that the scale values correspond to contact changeover on rising pressure, which is opposite to RT units with automatic reset.

Pressure switch, Differential pressure switch, type RT

Dimensions and weight

RT pressure switch housing

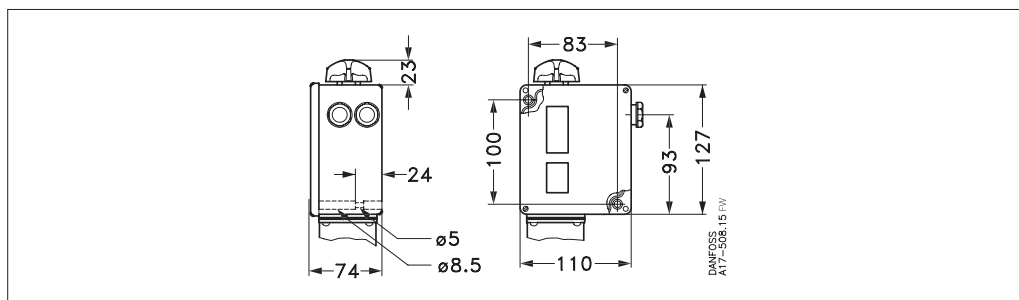

RT 1

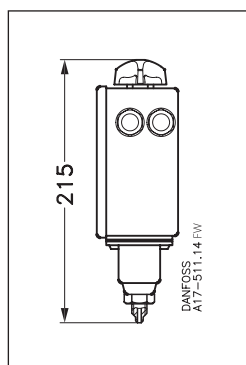

RT 1A, RT 1AL

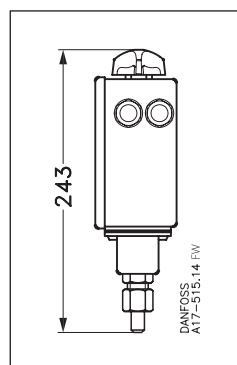

RT 1A, RT 1AL

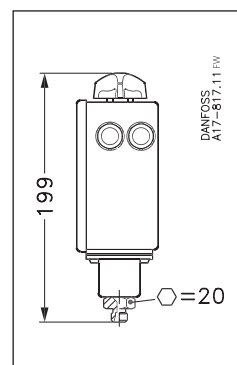

RT 6A

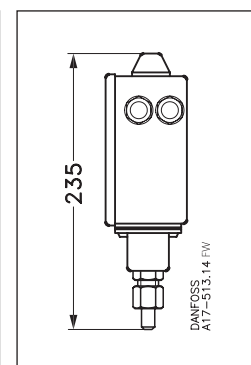

RT 6, RT 36

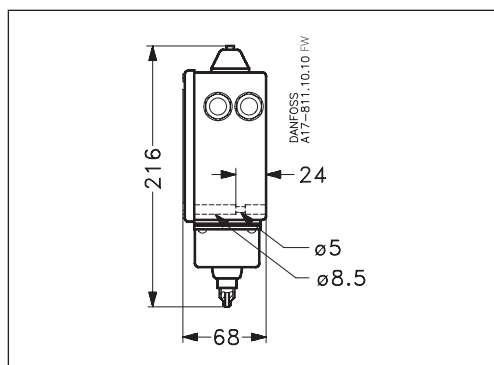

RT 30A

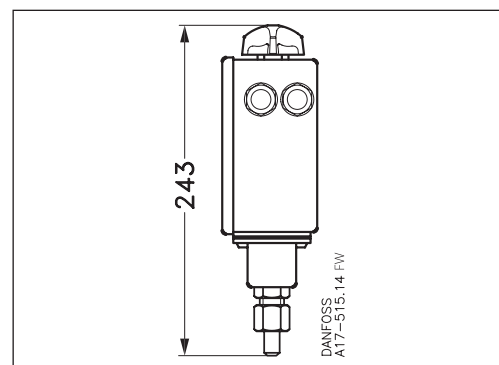

RT 117, RT 117L, RT 200, RT 200L

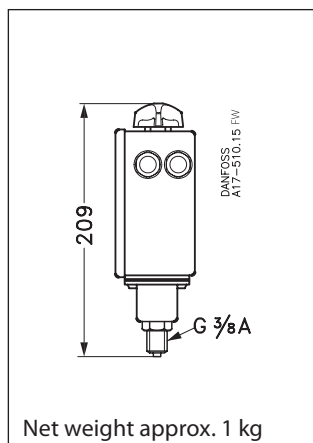

RT 260A

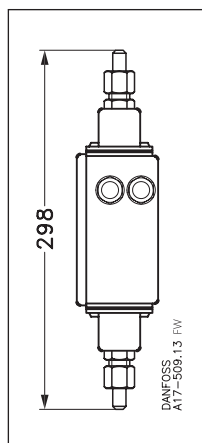

RT 262A

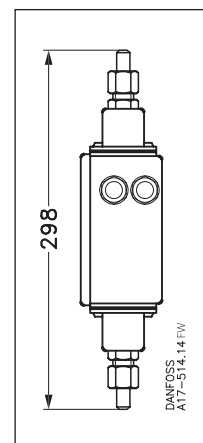

RT 260A, RT 262A

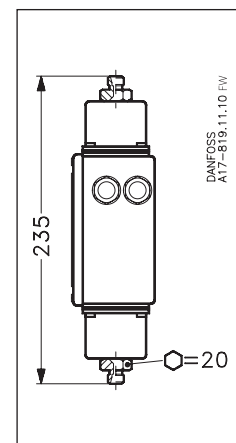

Differential pressure switch

MP 54, MP 55 and MP 55A

Contents

	Page
Features	59
Approvals	59
Ship approvals	59
Materials in contact with the medium	60
Technical data	60
Terminology	60
Ordering	61
Design	61
Function	62
Dimensions [mm] and weight [kg]	64

Differential pressure switch

MP 54, MP 55 and MP 55A



MP 54 and MP 55 oil differential pressure switches are used as safety switches to protect refrigeration compressors against low lubricating oil pressure.

If the oil pressure fails, the oil differential pressure switch stops the compressor after a certain time period.

MP 54 and MP 55 are used in refrigerating systems using HCFC and non-flammable HFC refrigerants.

MP 55A is used in refrigerating systems with R717. MP 55A can also be used in systems with HCFC and non-flammable HFC refrigerants.

MP 54 has a fixed differential pressure setting. It also incorporates a thermal time relay with a fixed release time setting.

MP 55 and MP 55A have adjustable differential pressure and are available both with and without thermal time relay.

Features

- Wide regulating range
- Can be used for deep freeze, refrigeration and air conditioning plant
- Can be used for HCFC and non-flammable HFC refrigerants
- Electrical connection at the front of the unit
- Suitable for both alternating and direct current (AC and DC)
- Screwed cable entry for cables from 6 – 14 mm diameter
- Small contact differential

Approvals

CE mark according to LVD 2006/95/EC
EN 60947-1, EN 60947-4-1, EN 60947-5-1

China Compulsory Certificate, CCC
Versions having UL and CSA approvals can be supplied to special order

Ship approvals

Germanischer Lloyd, GL
Registro Italiano Navale, RINA (MP55)

Differential pressure switch, MP 54, MP 55 and MP 55A

Materials in contact with the medium

Unit type	Material
MP 54 MP 55	Stainless steel 19/11, no. 1.4306 to EN 10088 Cold forming steel, no. 1.0338, EN 10139 Free cutting steel, no. 1.0718, EN 10277
MP 55A	Stainless steel 19/11, no. 1.4306 to EN 10088 Cold forming steel, no. 1.0338, EN 10139 Free cutting steel, no. 1.0401, EN 10277-2

Technical data

Control voltage	230 V or 115 V AC or DC	
Permissible voltage variation	-15 – 10%	
Max. working pressure	PS/MWP = 17 bar	
Max. test pressure	P _e = 22 bar	
Ambient temperature The time relay is temperature-compensated in the range	-40 – 60 °C	
Screwed cable entry	P _s 13.5	
Cable diameter	6 – 14 mm	
Max. bellows temperature	100 °C	
Switch differential max. Δp [bar]	0.2	
Enclosure	IP20 to EN 60529 / IEC 60529	
Contact loads	MP with time relay (contacts M-S)	AC15 = 2 A, 250 V
		DC13 = 0.2 A, 250 V
	MP without time relay	AC15 = 0.1 A, 250 V
		DC13 = 12 W, 125 V
Wire dimensions	solid / stranded	0.2 – 1.5 mm ²
	flexible, without ferrules	0.2 – 1.5 mm ²
	flexible, with ferrules	0.2 – 1 mm ²
Tightening torque	max. 1.2 Nm	
Rated impulse voltage	4 kV	
Pollution degree	3	
Short circuit protection, fuse	2 A	
Insulation	250 V	

Terminology

Differential range

The pressure difference between LP and OIL connections within which the switch can be set to operate.

Scale reading

The differential between the oil pump pressure and the pressure in the crankcase that exists at the moment the contact system cuts in current to the time relay on falling oil pressure.

Operating range

The pressure range on the LP connection within which the switch can operate.

Contact differential

The pressure rise above the set differential pressure (scale reading) necessary to cut off current to the time relay.

Release time

The period for which the differential pressure switch allows the compressor to run with too low an oil pressure during start-up and operation.

Differential pressure switch, MP 54, MP 55 and MP 55A

Ordering

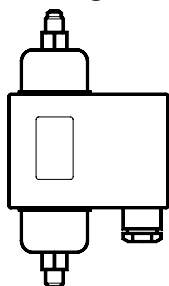

For R22, R134a, R404A, R407A, R407C, R407F, R422B, R422D, R448A, R449A, R450A, R452A, R507A, R513A
For complete list of approved refrigerants, go to <http://products.danfoss.com/all-products/>

Type	Differential Δp [bar]	Operation range, LP side [bar]	Relay release time [s]	Code no.		
				Connection		
				¼ in Flare	1 m cap.tube ¼ in ODF solder	M12 x 1.5 with 6 mm cutting ring
MP 54	0.65	-1 - 12	0 ²⁾	060B029766	-	-
	0.65	-1 - 12	45	060B016666	-	-
	0.9	-1 - 12	60	060B016766	-	-
	0.65	-1 - 12	90	060B016866	-	-
	0.65	-1 - 12	120	060B016966	-	-
MP 55	0.3 - 4.5	-1 - 12	45	060B017066	060B013366	-
	0.3 - 4.5	-1 - 12	60	060B017166	-	-
	0.3 - 4.5	-1 - 12	60	060B017866 ¹⁾	-	-
	0.3 - 4.5	-1 - 12	90	060B017266	-	-
	0.3 - 4.5	-1 - 12	120	060B017366	-	-
	0.3 - 4.5	-1 - 12	0 ²⁾	060B029966	-	-

For R22, R134a, R404A, R407A, R407C, R407F, R422B, R422D, R448A, R449A, R450A, R452A, R507A, R513A, R717*
For complete list of approved refrigerants, go to <http://products.danfoss.com/all-products/>

Type	Differential Δp [bar]	Operation range, LP side [bar]	Relay release time [s]	Code no.	
				Connection	
				G 3/8 A supplied with $\varnothing 6.5 / \varnothing 10$ mm weld nipple	M12 x 1.5 with 6 mm cutting ring
MP 55A	0.3 - 4.5	-1 - 12	45	060B017466	060B018266
	0.3 - 4.5	-1 - 12	60	060B017566	060B018366
	0.3 - 4.5	-1 - 12	60	060B017966 ¹⁾	-
	0.3 - 4.5	-1 - 12	90	060B017666	060B018466
	0.3 - 4.5	-1 - 12	120	060B017766	060B018566
	0.3 - 4.5	-1 - 12	0 ²⁾	060B029866 ²⁾	060B029666

¹⁾ With glow lamp that remains on during normal operation.

Note: If the operational light goes out, the compressor should not run longer than the release time.

^{*)} only for MP 55A

²⁾ MP without time relay. Versions without time relay are for applications where an external time relay is required – perhaps with a different release time than the one specified.

Design

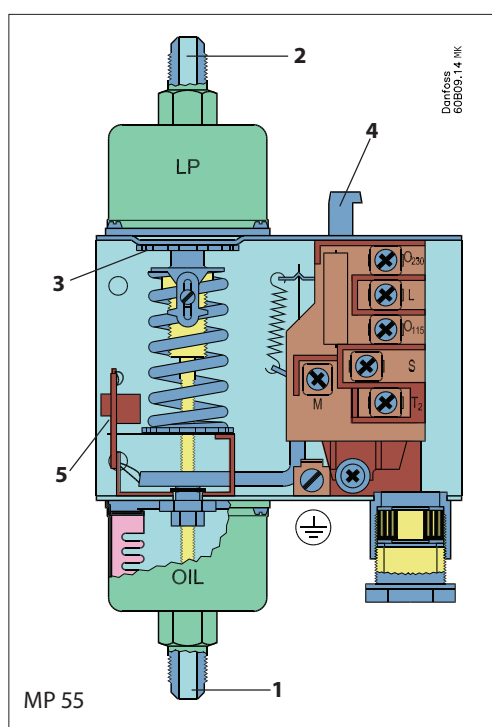

1. Connection to pressure side of lubrication system, OIL
2. Connection to suction side of refrigeration plant, LP
3. Setting disk (MP 55 and MP 55A)
4. Reset button
5. Test device

The operation of the pressure switch relies only on the differential pressure, i.e. the difference in pressure between the two counteracting bellows, whereas it is independent of the absolute pressure acting on both bellows.

The MP 55 and 55A can be set for different differential pressures by the setting disc (3).

The set differential pressure can be read from the internal scale.

The MP 54 has a fixed differential and has no pressure setting disc.

The factory-set differential pressure is stamped on the front plate of the switch.

Differential pressure switch, MP 54, MP 55 and MP 55A

Function

If there is no oil pressure on starting, or if the oil pressure falls below the set pressure during operation, the compressor will stop after the release time has elapsed.

The electrical circuit is divided into two completely separate circuits: a safety circuit and an operational circuit.

The timer (e) in the safety circuit is activated when the effective lubricating oil pressure, *the oil differential pressure* (the difference between the oil pump pressure and suction pressure), is lower than the set value.

The timer is deactivated when the oil differential pressure is more than the set value plus the contact differential.

Electrical diagram

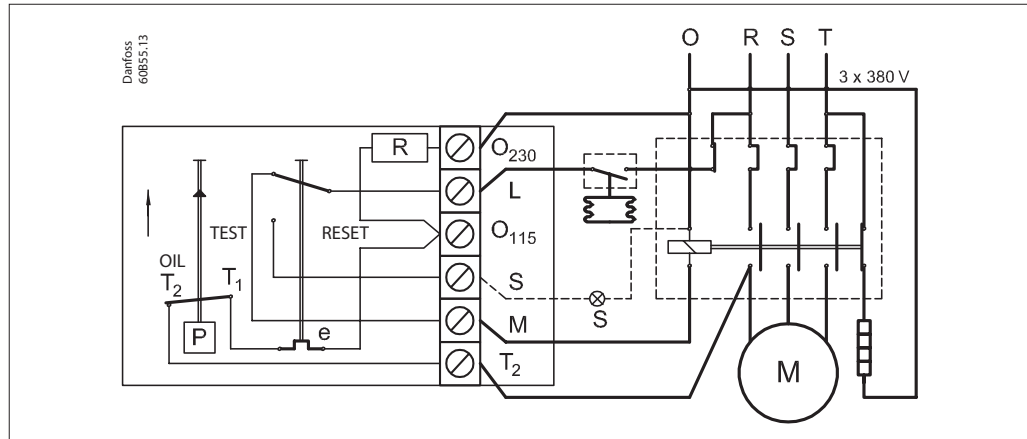

The two diagrams below explain the terms "oil differential pressure" and "contact differential". Both have to be considered when using oil differential pressure switches.

The first diagram shows the function of the differential switch during start; the second shows the function of the switch during operation.

During start

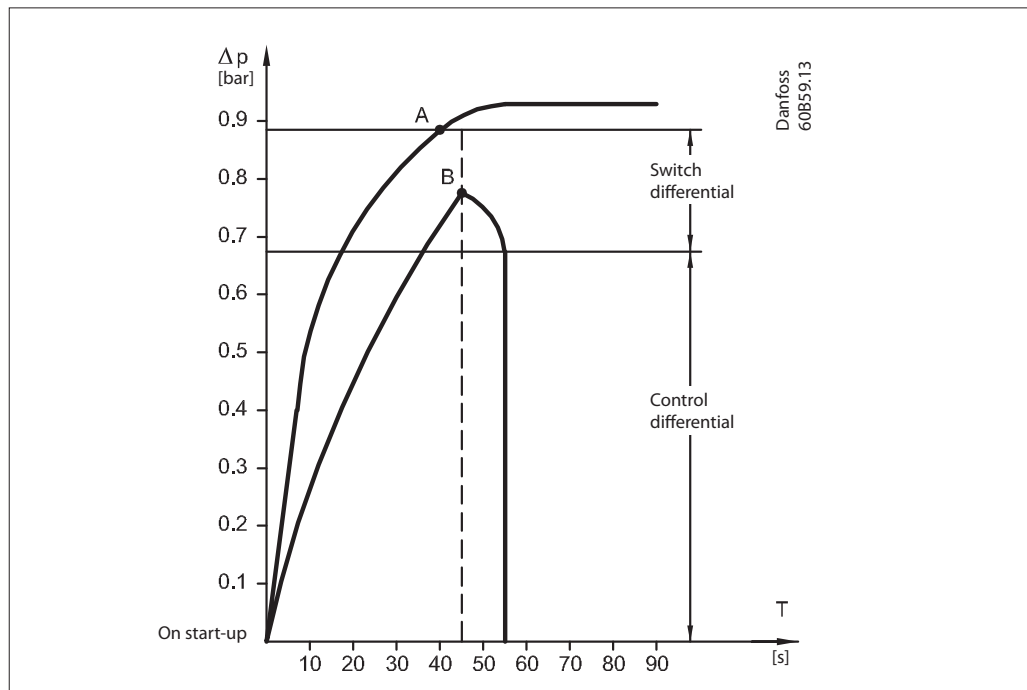

Pos. A: Normal start-up.

The lubricating oil pressure is built up during start to the set/fixed differential plus the contact differential, before the timer cuts out (in this example, after 45 seconds).

At point A contacts T1-T2 open and timer (e) is stopped, i.e. normal lubricating oil conditions for the compressor have been established.

Pos. B: The lubricating oil pressure does not

reach the set/fixed differential plus the contact differential before the timer period elapses.

At point B the timer cuts out operational circuit L-M and the compressor stops. If a signal source is connected to terminal S, it will be activated. Restart can only be performed after about 2 minutes by activation of the reset button, provided the cause of the fault has been determined.

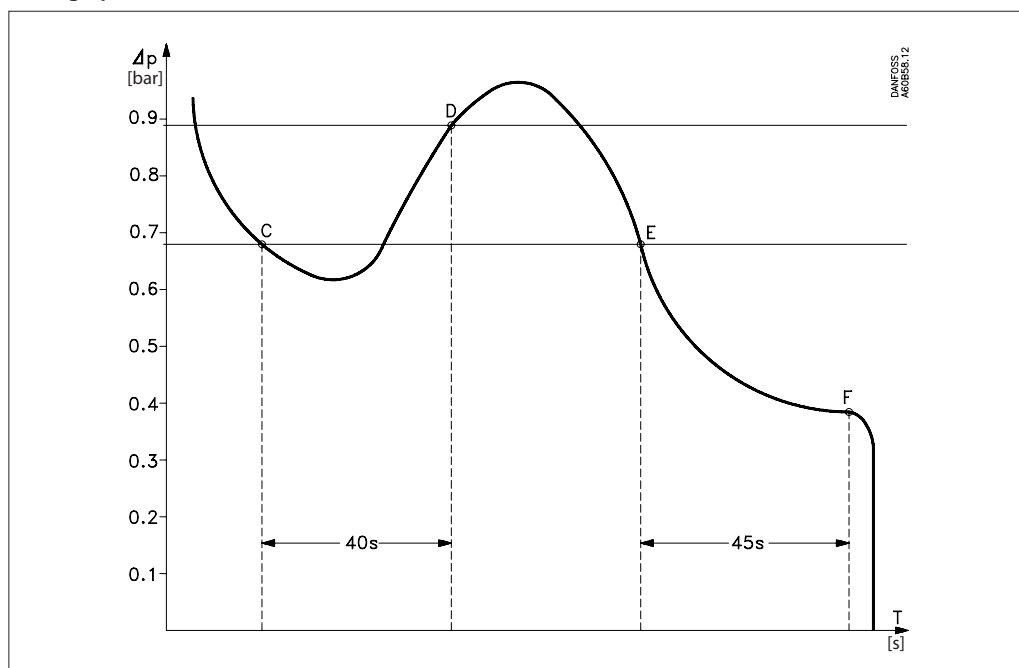
Function
(continued)
During operation

Pos. C: The lubricating oil pressure falls during operation to a value lower than the set/fixed differential. At point C, safety circuit T1-T2 cuts in and the timer is activated.

Pos. D: The lubricating oil pressure reaches the set/fixed differential plus the contact differential before the timer period elapses. At point D, safety circuit T1-T2 cuts out and the timer is stopped, i.e. normal lubricating oil conditions for the compressor have been established.

Pos. E: The lubricating oil pressure falls to a value lower than the set/fixed differential during operation. At point E, safety circuit T1-T2 cuts in and the timer is activated.

Pos. F: The lubricating oil pressure remains lower than the set/fixed differential. At point F the timer cuts out operational circuit L-M and the compressor stops. If a signal source is connected to terminal S, it will be activated. Restart can only be performed after about 2 minutes by activation of the reset button, provided the cause of the fault has been determined.

After start-up

It is important that a function check should be made to ensure that the differential pressure control is operating as it should.

This check can be made by pressing the test device (inside the unit on the left hand side).

When the test device is pressed down and held in this position, the compressor motor should stop after the release time determined by the time relay has elapsed.

Liquid level switch

Type AKS 38

Contents

	Page
Features	67
Technical data	68
Design	68
Function	69
Application	70
Ordering	70
Dimensions	71
Spare parts	71

Liquid level switch

Type AKS 38



AKS 38 is an electro-mechanical liquid level switch designed to provide a reliable, electro-mechanical response to liquid level changes.

The simple and basic design ensures long lifetime performance and reliable operation for many applications.

AKS 38 can control liquid level in vessels and accumulators or can be used as a low / high level alarm.

Features

- Based on Danfoss liquid level switch type 38E
- DIN, ANSI and FPT/NPT flanges
- The switch box can be placed in any position on top of float housing for ease of installation.
- Adjustable liquid level differential switch point
- Electric magnetic microswitch, mechanically activated
- The complete switch box can easily be replaced without any interference with the refrigeration system
- Switch box supplied with a DIN plug for easy installation and service
- Flanges included
- Classification: DNV, CRN, BV, EAC etc.
To get an updated list of certification on the products please contact your local Danfoss Sales Company

Technical data

- *Refrigerants*
Applicable to HCFC, non flammable HFC and R717 (Ammonia).
Flammable hydrocarbons are not recommended
- *Temperature range*
-50 – 65°C / -58 – 149 °F
- *Pressure range*
AKS 38 is designed for a max. working pressure of 28 bar g / 406 psi g



IMPORTANT

Should pressure testing in excess of 28 bar g / 406 psig be necessary then the internal float assembly must be removed, thus allowing a maximum test pressure of 42 bar g / 609 psig.

Liquid level switch, type AKS 38

Technical data

- | | |
|---|---|
| <ul style="list-style-type: none"> • <i>Material</i>
<i>Float housing:</i>
Cast Iron, zinc chromated,
EN-GJS-400-18-LT <i>Floats housing bolts:</i>
Stainless steel
A2-70 (DIN 267-11) / ASTM A-276 <i>Flanges:</i>
P285QH
EN 10222-4 / ASTM A350 <i>Flange gasket:</i>
Fiber, non asbestos | <ul style="list-style-type: none"> <i>Pressure tube:</i>
Stainless steel
X5CrNi18-10, EN 10088 / AISI 304, A276 <i>O-ring:</i>
Neoprene (Cloroprene) <i>Gasket between pressure tube and housing</i>
Aluminium <i>Electrical switch box:</i>
Shock resistant polycarbonate
CT-661-T |
|---|---|
-
- | | |
|---|--|
| <ul style="list-style-type: none"> • <i>Electrical data</i> <ul style="list-style-type: none"> - Change over Micro (SPDT) switch
250 V a.c / 10 A
30 V d.c / 5 A
Normally Open (NO) and Normally Closed (NC) function - DIN Plug
DIN 43650 connection
PG 11, 8-10 mm (0.31"– 0.39")
Screw terminal 1.5 mm² (16 AWG)
3+PE • <i>Liquid level differential</i>
Variable between 12.5 mm to 50 mm (½" to 2") in 12.5 mm (½") increments. Required differential setting should be made prior to installation.
Factory set at 50 mm (2"). | <ul style="list-style-type: none"> • <i>Enclosure</i>
IP 65 • <i>Weight (including flanges)</i>
9.75 kg (21.5 lb) • <i>Approvals</i>
CE – for further details please see instruction. |
|---|--|

Design

AKS 38 is an electro-mechanical liquid level switch.

The design is based on a mechanical float, which will operate in the refrigerant. When the set level is reached an electrical volt free micro (SPDT) switch will be activated.

The microswitch is located in the switch box which has a clear front cover and allows viewing of the switch position. The micro- switch is fully isolated from the refrigeration system and operates by means of a magnet.

AKS 38 is supplied with a DIN plug for the

electrical connections. The microswitch provides volt free contacts to open / close solenoid valves or energise / de-energise contactors for the starting / stopping refrigerant pumps / compressors.

Can be used as a device for acoustic alarms / switches for visual indication when there is a danger of high or low liquid level.

The switch box can be placed in any position on top of the float housing for easy installation and can be replaced without any interference with the refrigeration system.
Flanges are included.

Liquid level switch, type AKS 38

Function

- 1 Internal float assembly
- 2 Switch box
- 3 M4x8 pinol tailstock screw
- 4 Top cover
- 5 4 pcs M12x35 stainless steel bolts
- 6 AKS 38 housing
- 7 Pressure tube
- 8 Top cover gasket
- 9 O-ring for pressure tube
- 10 DIN-plug for electrical connection
- 11 Aluminium gasket
- 12 Locking ring for internal float
- 13 Stainless steel bolts
- 14 Flanges
- 15 Flange gaskets

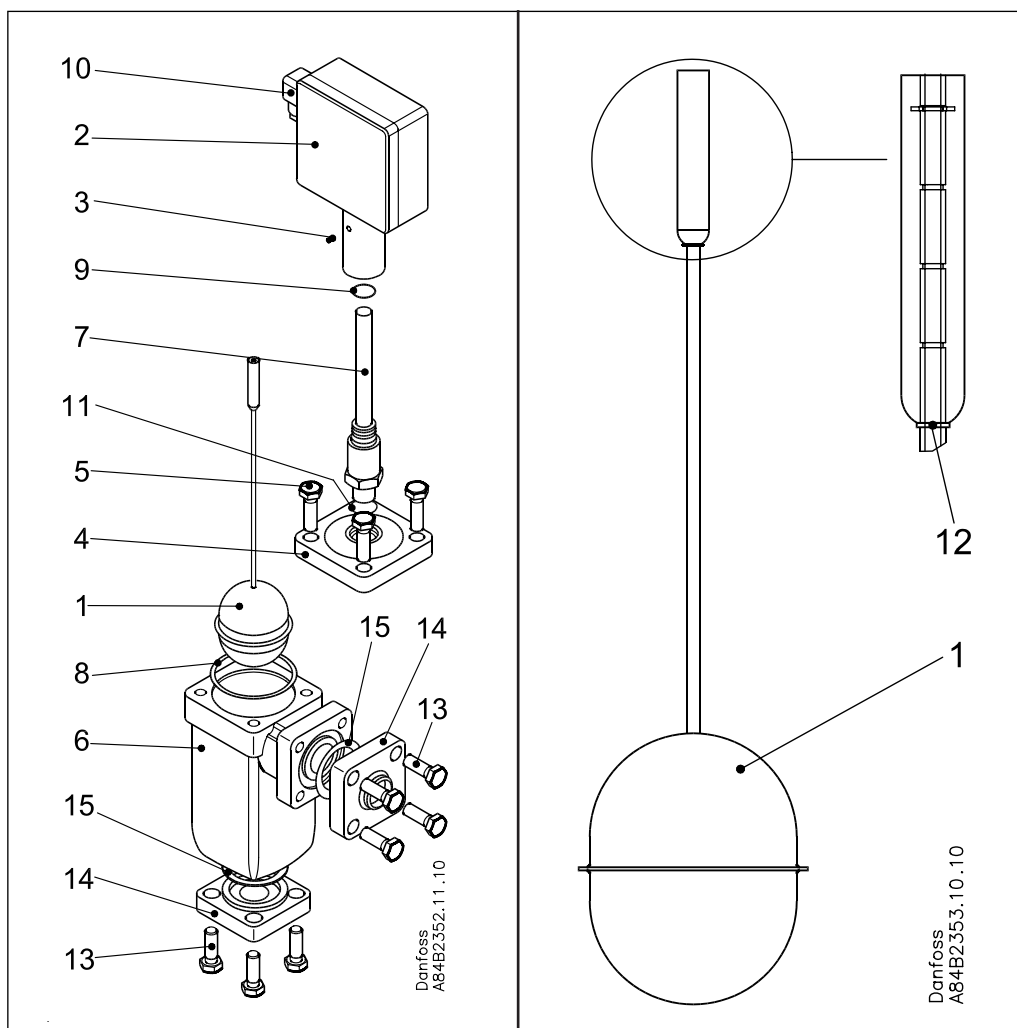

AKS 38 incorporates an internal float assembly (1), which will operate directly in accordance with the refrigerant level.

The internal float will follow the liquid level vertically up and down.

The upper part of the internal float assembly moves within the pressure tube (7).

At a specific switch point the upper part of the internal float assembly will via a magnet activate the electrical microswitch in the switch box (2).

A volt free signal can be detected by wiring to terminals at the DIN-plug (10). The actual switch point can be adjusted by means of a locking ring (12) before installation.

Liquid level switch, type AKS 38

Function

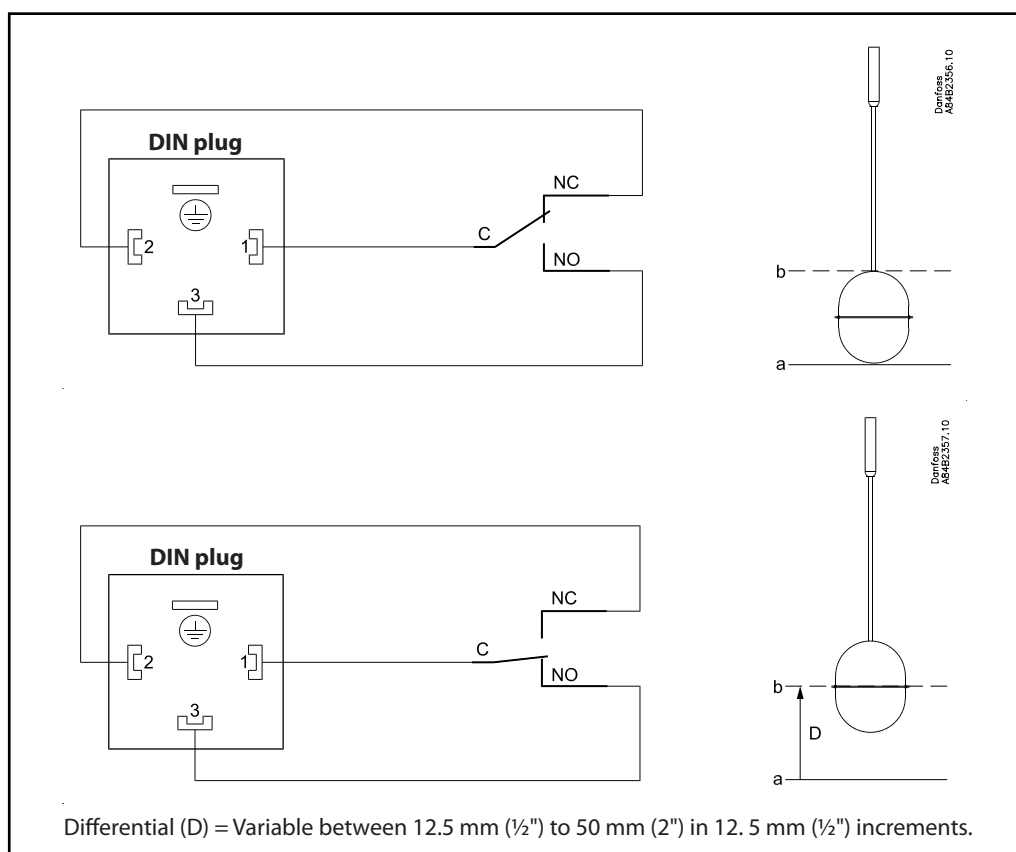

Application

- For the control and detection of liquid levels in: -
- Liquid over-feed accumulators.
 - Flooded surge drums.
 - Flooded shell & tube chillers.
 - High and low pressure receivers.
 - Inter coolers.
 - Use as low / high level switch to protect circulating pumps / compressors.

Ordering

Type	Code No.
AKS 38 Butt Weld, DIN DN 25 (1 in)	148H3194
AKS 38 Butt Weld, ANSI DN 25 (1 in)	148H3204
AKS 38 Socket Weld, ANSI DN 20 (3/4 in)	148H3205
AKS 38 Socket Weld, ANSI DN 25 (1 in)	148H3206
AKS 38 FPT, NPT DN 20 (3/4 in)	148H3207

Liquid level switch, type AKS 38

Dimensions

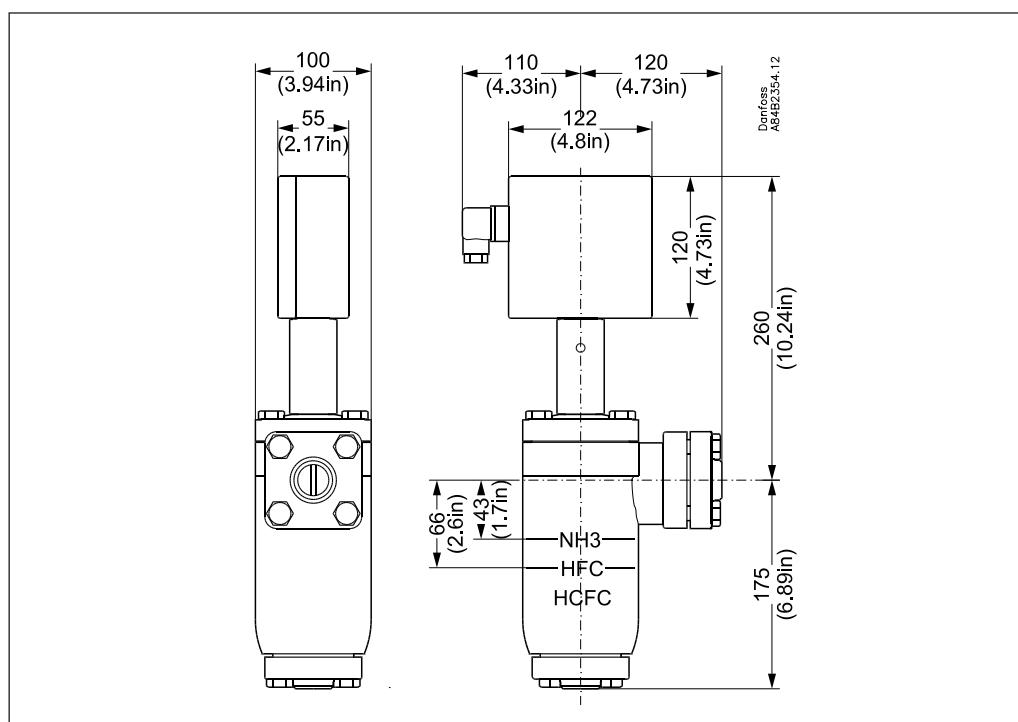

Spare parts

Type	Code no.
Repair kit:	148H3200
Top cover gasket	
O-ring for pressure tube	
Alu. gasket	
Flange gasket	
Locking ring for internal float	
Internal float assembly	148H3203
Electrical switch box	148H3202
Flanges:	
AKS 38 Butt Weld, DIN DN 25 (1 in)	027N1026
AKS 38 Butt Weld, ANSI DN 25 (1 in)	027N2023
AKS 38 Socket Weld, ANSI DN 20 (3/4 in)	027N2012
AKS 38 Socket Weld, ANSI DN 25 (1 in)	027N2013
AKS 38 FPT, NPT DN 20 (3/4 in)	027G1007
Please observe: Same flanges as for NRVA 25 and NRVA 32	

ENGINEERING
TOMORROW

Danfoss