

Thermostatic expansion valves Type TDE and TDEB

Contents

	Page
Introduction.....	3
Features.....	3
Thermostatic charge options.....	3
Standard valve options.....	4
Technical data.....	4
MOP valves.....	4
Sizing.....	4
Ordering R22.....	6
Ordering R407C.....	8
Capacity R22.....	10
Capacity R407C.....	13
Design and function.....	16
Application.....	17
Operation and function.....	18
Identification.....	19
Dimensions and weights.....	19
ISO 9001 quality approval.....	20

Metric conversions

1 psi = 0.07 bar

 $\frac{5}{9}(t_1^{\circ}\text{F} - 32) = t_2^{\circ}\text{C}$

1 ton = 3.5 kW

1 in. = 25.4 mm

1 ft = 0.3 m

1 lb = 0.454 kg

Introduction

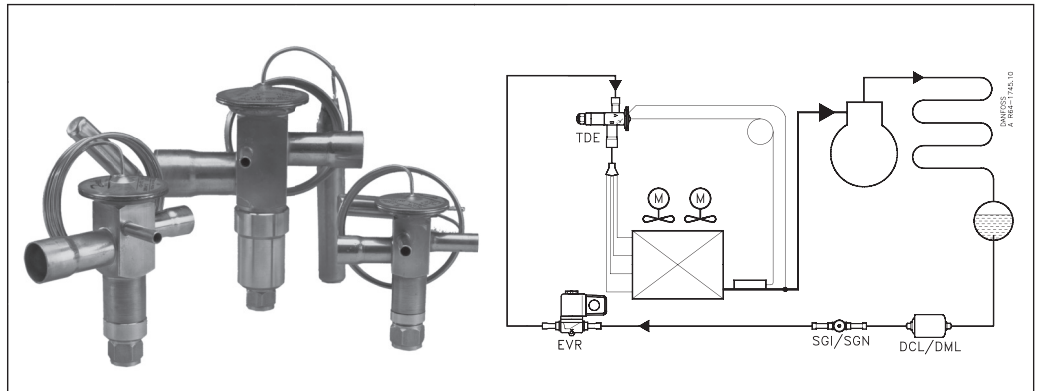

The TD series of thermostatic expansion valves is designed for use in:

- Air conditioning systems
- Heat pumps
- Water chillers
- Refrigerated containers
- Traditional refrigeration systems

The TD product program consist of two hermetic valve designs:

Single port (type TDE) and balanced port (type TDEB). Valve selection is determined by the application and the capacity required.

Single port version (type TDE)

The single port's simplified construction is designed for use on systems with small capacities (3 to 7.5 TR R22). Single port design is effective because in smaller capacities condensing pressure is negligible. Type TDE single port valves can also be used for bi-flow applications in the same capacity range.

Balanced port versions (type TDEB)

The balanced port design has been developed for large capacity systems (greater than 8 TR R22) where fluctuating condensing pressures are present.

The balanced port feature eliminates any influence by condensing pressure on the expansion valve function in the normal flow direction.

The TDEB design is unique in that it also provides a balance function in the reverse flow direction making it ideal for use in bi-flow applications.

All TD valves are available with a selection of bulb charges with or without maximum operating pressure (MOP) function.

Single and industrial pack quantities are available.

Features

Hermetically sealed solder valves

- Reduces the possibility of leaks in your system

Laser-welded, stainless steel thermostatic element

- Provides longer diaphragm life, protection against corrosion and optimum pressure strength

Bi-flow function

- Reduces installation costs by reducing the number of valves required in a heat pump application

Patented double-contact bulb

Allows for quick and easy installation and provides for good heat transfer between pipe and sensor

Available Refrigerants

- R22, R407C, R 134a (special order)

Versions available with:

- Self-cleaning bleed
- Maximum operating pressure (MOP) function
- Bi-flow function

Thermostatic charge options

Metric conversions

1 psi = 0.07 bar
 $\frac{5}{9}(t_1^{\circ}\text{F} - 32) = t_2^{\circ}\text{C}$
 1 ton = 3.5 kW

Danfoss offers the following *standard range* of thermostatic charges:

R22, range K:	-15 to 50°F,	MOP 100 psig
R22, range AC:	15 to 60°F,	MOP 120 psig
R22, range N:	-40 to 50°F	
R407C, range K:	-15 to 50°F,	MOP 95 psig
R407C, range AC:	15 to 60°F,	MOP 115 psig
R407C, range N:	-40 to 50°F	

Standard valve options

Static superheat (SS) (R22, R407C):
 Valves without MOP: 7° F
 Valves with MOP: 7° F

Capillary tube length
 TD 3 - 19: 5 ft
 TD 20 - 40: 10 ft

Connections sizes

Inlet	Outlet
3/8 in. ODF 1/2 in. ODF	5/8 in. ODF
1/2 in. ODF 5/8 in. ODF	7/8 in. ODF
5/8 in. ODF 7/8 in. ODF	1 1/8 in. ODF
7/8 in. ODF 1 1/8 in. ODF	1 3/8 in. ODF

External equalization: 1/4 in. ODF

Technical data

Maximum bulb temperature
 with MOP 302°F
 without MOP 212°F
Maximum valve body temperature 250°F
Valve body temperature short-term 300°F
Maximum working pressure MWP 405 psig
Maximum test pressure p' = 465 psig

Bleed 15% (special order)

Biflow operation

TDEB with two-way balanced port and universal cross-ambient charge is designed for biflow operation. With flow in the opposite direction, the rated capacity is reduced by 15%.

Note: TDE types with MOP charges cannot be used for biflow operation.

MOP valves
MOP-points

Refrigerant	Range K -15 → 0°F	Range AC -15 → 0°F
	MOP point for evaporating temperature t_e and evaporating pressure p_e $t_e = 60^\circ\text{F}$	
R22	$p_e = 100$ psig	$p_e = 120$ psig
R407C	$p_e = 95$ psig	$p_e = 115$ psig

Note: To avoid charge migration when MOP valves are used, the bulb temperature must be lower than the thermostatic element temperature.

Sizing

For optimum performance, it is important to select a TD valve according to system conditions and application. Selecting an incorrect valve will result in operational difficulties or poor system performance. The following selection procedure will help you select the correct valve for your needs.

Example:

Refrigerant: R22
 Evaporator capacity: $Q_e = 6.5$ TR
 Evaporator with several sections, i.e. a valve with distributor is required:
 Evaporating temperature: $t_e = 30^\circ\text{F} \sim 55$ psig
 Condensing temperature: $t_c = 100^\circ\text{F} \sim 195$ psig
 Refrigerant liquid temperature: $t_l = 80^\circ\text{F}$
 Evaporating temperature: $t_e = 30^\circ\text{F} \sim 55$ psig
 Subcooling: $\Delta t_{sub} = 100^\circ\text{F} - 80^\circ\text{F} = 20^\circ\text{F}$

Metric conversions
 1 psi = 0.07 bar
 $5/9 (t_1^\circ\text{F} - 32) = t_2^\circ\text{C}$
 1 ton = 3.5 kW
 1 in. = 25.4 mm
 1 ft = 0.3 m

Sizing (continued)

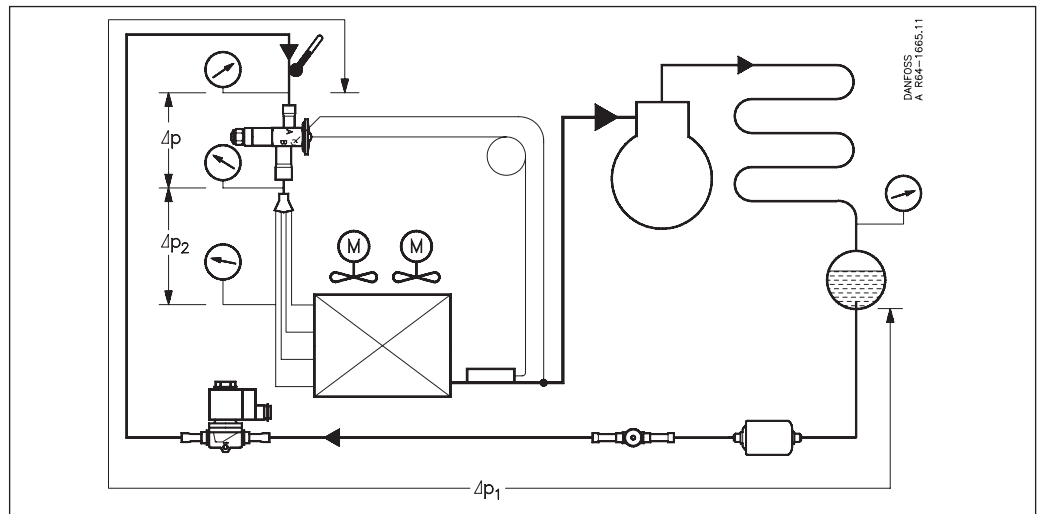

Step 1

Determine the pressure drop across the valve. The pressure drop, Δp , is calculated by the formula:

$$\Delta p = p_c - p_e - pdw \quad \text{where}$$

p_c = condensing pressure
 p_e = evaporating pressure, and
 pdw = the sum of other pressure drops in the liquid line, evaporator, and distributor.

The pressures p_c and p_e can be found by using the design condensing and evaporating temperatures at the saturated vapor point and using a pressure-temperature chart or a Danfoss refrigerant slide to convert the temperatures to pressures.

In this example, the pressure drop across the valve will be:

$$\Delta p = p_c - p_e = 195 - 70 = 125 \text{ psi.}$$

Step 2

Determine required valve capacity.

Use the design evaporator capacity, Q_e , to select the required valve size at a given evaporating temperature. If necessary, correct the evaporator capacity for subcooling. Subcooled liquid refrigerant entering the evaporator increases evaporator capacity, and a smaller valve may be required.

In this example, the subcooling is:

$$\Delta t_{\text{sub}} = t_c - t_l = 100 - 80 = 20^\circ\text{F}$$

From the subcooling correction factor table, on page 6, we find the appropriate correction factor F_{sc} equals 0.94 for $\Delta t_{\text{sub}} = 20^\circ\text{F}$.

Now, determine the required valve capacity by multiplying the evaporator capacity by the correction factor for subcooling.

$$\text{Required valve capacity} \\ Q_e \times F_{sc} = 6.5 \times 0.94 = 6.1 \text{ TR}$$

Step 3

Use the calculated valve capacity to select the corresponding orifice size from the capacity table for R22 on page 10.

Note that the expansion valve capacity must be equal to or slightly greater than the corrected evaporator capacity.

In this sizing example, TDEX 7.5 will be suitable.

Step 4

Finally, determine connection sizes, then find the valve's code number from the tables on page 6 or 7.

Metric conversions
 1 psi = 0.07 bar
 $\frac{5}{9}(t_1^\circ\text{F} - 32) = t_2^\circ\text{C}$
 1 ton = 3.5 kW

Ordering

The valves and bulb straps are supplied in industrial packs or multipacks:
 Industrial pack, TD 3 - 19: 12 valves
 Industrial pack, TD 20 - 40: 8 valves

Multipack, TD 3 - 7.5: 12 valves
 Multipack, TD 8 - 19: 8 valves
 Multipack, TD 20 - 40: 6 valves

Order table

Refrigerant	Range	Temperature range	MOP	Ordering
R22	K	- 15 to 50°F	MOP 60°F	See page 9
R22	AC	15 to 60°F	MOP 68°F	See page 10
R22	N	- 40 to 50°F		See page 11
R407C	K	- 15 to 50°F	MOP 60°F	See page 12
R407C	AC	15 to 60°F	MOP 68°F	See page 13
R407C	N	- 40 to 50°F		See page 14
R 134a	K	- 15 to 50°F	MOP 60°F	Special order, contact Danfoss
R 134a	N	- 40 to 50°F		Special order, contact Danfoss

R22

Range K = -15 to 50°F with MOP 100 psig

Type and rated capacity ¹⁾ A × B TR	Connection solder ODF × ODF in.	Code no. Multipack	Code no. Industrial pack
TDEX 3	$\frac{3}{8} \times \frac{5}{8}$	068H6200	068H4150
TDEX 3	$\frac{1}{2} \times \frac{5}{8}$	068H6201	068H4151
TDEX 4	$\frac{1}{2} \times \frac{7}{8}$	068H6202	068H4152
TDEX 6	$\frac{1}{2} \times \frac{5}{8}$	068H6234	068H4184
TDEX 6	$\frac{1}{2} \times \frac{7}{8}$	068H6203	068H4153
TDEX 6	$\frac{5}{8} \times \frac{7}{8}$	068H6204	068H4154
TDEX 7.5	$\frac{5}{8} \times \frac{7}{8}$	068H6205	068H4155

Range K = -15 to 50°F with MOP 100 psig

Type and rated capacity ¹⁾ A × B TR	Connection solder ODF × ODF in.	Code no. Multipack	Code no. Industrial pack
TDEBX 8	$\frac{5}{8} \times \frac{7}{8}$	068H7130	068H8000
TDEBX 11	$\frac{5}{8} \times \frac{7}{8}$	068H7132	068H8002
TDEBX 11	$\frac{5}{8} \times 1\frac{1}{8}$	068H7134	068H8004
TDEBX 12.5	$\frac{5}{8} \times \frac{7}{8}$	068H7136	068H8006
TDEBX 12.5	$\frac{5}{8} \times 1\frac{1}{8}$	068H7138	068H8008
TDEBX 16	$\frac{5}{8} \times 1\frac{1}{8}$	068H7140	068H8010
TDEBX 16	$\frac{7}{8} \times 1\frac{1}{8}$	068H7142	068H8012
TDEBX 19	$\frac{7}{8} \times 1\frac{1}{8}$	068H7144	068H8014

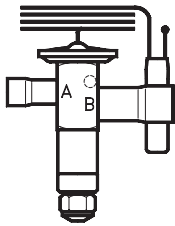
TDEX 3 - 7.5 Single port

TDEX 3	$\frac{3}{8} \times \frac{5}{8}$	068H6200	068H4150
TDEX 3	$\frac{1}{2} \times \frac{5}{8}$	068H6201	068H4151
TDEX 4	$\frac{1}{2} \times \frac{7}{8}$	068H6202	068H4152
TDEX 6	$\frac{1}{2} \times \frac{5}{8}$	068H6234	068H4184
TDEX 6	$\frac{1}{2} \times \frac{7}{8}$	068H6203	068H4153
TDEX 6	$\frac{5}{8} \times \frac{7}{8}$	068H6204	068H4154
TDEX 7.5	$\frac{5}{8} \times \frac{7}{8}$	068H6205	068H4155

TDEBX 8 - 19 Balanced port

TDEBX 8	$\frac{5}{8} \times \frac{7}{8}$	068H7130	068H8000
TDEBX 11	$\frac{5}{8} \times \frac{7}{8}$	068H7132	068H8002
TDEBX 11	$\frac{5}{8} \times 1\frac{1}{8}$	068H7134	068H8004
TDEBX 12.5	$\frac{5}{8} \times \frac{7}{8}$	068H7136	068H8006
TDEBX 12.5	$\frac{5}{8} \times 1\frac{1}{8}$	068H7138	068H8008
TDEBX 16	$\frac{5}{8} \times 1\frac{1}{8}$	068H7140	068H8010
TDEBX 16	$\frac{7}{8} \times 1\frac{1}{8}$	068H7142	068H8012
TDEBX 19	$\frac{7}{8} \times 1\frac{1}{8}$	068H7144	068H8014

TDEBX 20 - 40 Balanced port

TDEBX 20	$\frac{7}{8} \times 1\frac{1}{8}$	068H7146	068H8016
TDEBX 26	$\frac{7}{8} \times 1\frac{3}{8}$	068H7148	068H8018
TDEBX 30	$\frac{7}{8} \times 1\frac{3}{8}$	068H7150	068H8020
TDEBX 30	$1\frac{1}{8} \times 1\frac{3}{8}$	068H7152	068H8022
TDEBX 40	$1\frac{1}{8} \times 1\frac{3}{8}$	068H7154	068H8024

¹⁾ The rated capacity is based on:
 Evaporating temperature $t_e = 40^\circ\text{F}$
 Liquid temperature $t_l = 80^\circ\text{F}$
 Condensing temperature $t_c = 90^\circ\text{F}$

Metric conversions
 1 psi = 0.07 bar
 $\frac{5}{9} (t_1^\circ\text{F} - 32) = t_2^\circ\text{C}$
 1 ton = 3.5 kW
 1 in. = 25.4 mm

Ordering (continued)

R22

Range AC = 15 to 60°F with MOP 120 psig

Type and rated capacity ¹⁾ A × B TR	Connection solder ODF × ODF in.	Code no. Multipack	Code no. Industrial pack
--	---------------------------------------	-----------------------	-----------------------------

Range AC = 15 to 60°F with MOP 120 psig

Type and rated capacity ¹⁾ A × B TR	Connection solder ODF × ODF in.	Code no. Multipack	Code no. Industrial pack
--	---------------------------------------	-----------------------	-----------------------------

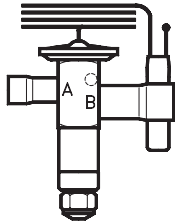

TDEX 3 - 7.5 Single port

TDEX 3	$\frac{3}{8} \times \frac{5}{8}$	068H6100	068H4100
TDEX 3	$\frac{1}{2} \times \frac{5}{8}$	068H6101	068H4101
TDEX 4	$\frac{1}{2} \times \frac{7}{8}$	068H6102	068H4102
TDEX 6	$\frac{1}{2} \times \frac{5}{8}$	068H6134	068H4134
TDEX 6	$\frac{1}{2} \times \frac{7}{8}$	068H6103	068H4103
TDEX 6	$\frac{5}{8} \times \frac{7}{8}$	068H6104	068H4104
TDEX 7.5	$\frac{5}{8} \times \frac{7}{8}$	068H6105	068H4105

TDEBX 8 - 19 Balanced port

TDEBX 8	$\frac{5}{8} \times \frac{7}{8}$	068H7100	068H8026
TDEBX 11	$\frac{5}{8} \times \frac{7}{8}$	068H7102	068H8028
TDEBX 11	$\frac{5}{8} \times 1\frac{1}{8}$	068H7104	068H8030
TDEBX 12.5	$\frac{5}{8} \times \frac{7}{8}$	068H7106	068H8032
TDEBX 12.5	$\frac{5}{8} \times 1\frac{1}{8}$	068H7108	068H8034
TDEBX 16	$\frac{5}{8} \times 1\frac{1}{8}$	068H7110	068H8036
TDEBX 16	$\frac{7}{8} \times 1\frac{1}{8}$	068H7112	068H8038
TDEBX 19	$\frac{7}{8} \times 1\frac{1}{8}$	068H7114	068H8040

TDEBX 20 - 40 Balanced port

TDEBX 20	$\frac{7}{8} \times 1\frac{1}{8}$	068H7116	068H8042
TDEBX 26	$\frac{7}{8} \times 1\frac{3}{8}$	068H7118	068H8044
TDEBX 30	$\frac{7}{8} \times 1\frac{3}{8}$	068H7120	068H8046
TDEBX 30	$1\frac{1}{8} \times 1\frac{3}{8}$	068H7122	068H8048
TDEBX 40	$1\frac{1}{8} \times 1\frac{3}{8}$	068H7124	068H8050

¹⁾ The rated capacity is based on:
Evaporating temperature $t_e = 40^\circ\text{F}$
Liquid temperature $t_l = 80^\circ\text{F}$
Condensing temperature $t_c = 90^\circ\text{F}$

R22

Range N = -40 to 50°F

Type and rated capacity ¹⁾ A × B TR	Connection solder ODF × ODF in.	Code no. Multipack	Code no. Industrial pack
--	---------------------------------------	-----------------------	-----------------------------

Range N = -40 to 50°F

Type and rated capacity ¹⁾ A × B TR	Connection solder ODF × ODF in.	Code no. Multipack	Code no. Industrial pack
--	---------------------------------------	-----------------------	-----------------------------

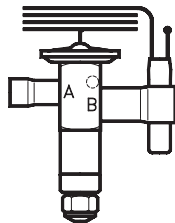

TDEX 3 - 7.5 Single port

TDEX 3	$\frac{3}{8} \times \frac{5}{8}$	068H7050	068H8106
TDEX 3	$\frac{1}{2} \times \frac{5}{8}$	068H7052	068H8054
TDEX 4	$\frac{1}{2} \times \frac{7}{8}$	068H7054	068H8056
TDEX 6	$\frac{1}{2} \times \frac{5}{8}$	068H7056	068H8058
TDEX 6	$\frac{1}{2} \times \frac{7}{8}$	068H7058	068H8060
TDEX 6	$\frac{5}{8} \times \frac{7}{8}$	068H7060	068H8062
TDEX 7.5	$\frac{5}{8} \times \frac{7}{8}$	068H7062	068H8064

TDEBX 8 - 19 Balanced port

TDEBX 8	$\frac{5}{8} \times \frac{7}{8}$	068H7064	068H8082
TDEBX 11	$\frac{5}{8} \times \frac{7}{8}$	068H7066	068H8084
TDEBX 11	$\frac{5}{8} \times 1\frac{1}{8}$	068H7068	068H8086
TDEBX 12.5	$\frac{5}{8} \times \frac{7}{8}$	068H7070	068H8088
TDEBX 12.5	$\frac{5}{8} \times 1\frac{1}{8}$	068H7072	068H8090
TDEBX 16	$\frac{5}{8} \times 1\frac{1}{8}$	068H7074	068H8092
TDEBX 16	$\frac{7}{8} \times 1\frac{1}{8}$	068H7076	068H8094
TDEBX 19	$\frac{7}{8} \times 1\frac{1}{8}$	068H7078	068H8096

TDEBX 20 - 40 Balanced port

TDEBX 20	$\frac{7}{8} \times 1\frac{1}{8}$	068H7080	068H8098
TDEBX 26	$\frac{7}{8} \times 1\frac{3}{8}$	068H7082	068H8100
TDEBX 30	$\frac{7}{8} \times 1\frac{3}{8}$	068H7084	068H8102
TDEBX 30	$1\frac{1}{8} \times 1\frac{3}{8}$	068H7086	068H8104
TDEBX 40	$1\frac{1}{8} \times 1\frac{3}{8}$	068H7088	068H8080

¹⁾ The rated capacity is based on:
Evaporating temperature $t_e = 40^\circ\text{F}$
Liquid temperature $t_l = 80^\circ\text{F}$
Condensing temperature $t_c = 90^\circ\text{F}$

Metric conversions
1 psi = 0.07 bar
 $\frac{5}{9} (t_1^\circ\text{F} - 32) = t_2^\circ\text{C}$
1 ton = 3.5 kW
1 in. = 25.4 mm

Ordering (continued)

R407C

Range K = -15 to 50°F with MOP 95 psig

Type and rated capacity ¹⁾ A × B TR	Connection solder ODF × ODF in.	Code no. Multipack	Code no. Industrial pack
--	---------------------------------------	-----------------------	-----------------------------

Range K = -15 to 50°F with MOP 95 psig

Type and rated capacity ¹⁾ A × B TR	Connection solder ODF × ODF in.	Code no. Multipack	Code no. Industrial pack
--	---------------------------------------	-----------------------	-----------------------------

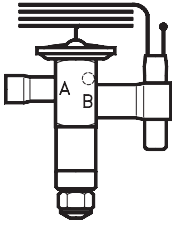
TDEZ 3 - 7.5 Single port

TDEZ 3	$\frac{3}{8} \times \frac{5}{8}$	068H7160	068H5150
TDEZ 3	$\frac{1}{2} \times \frac{5}{8}$	068H7161	068H5151
TDEZ 4	$\frac{1}{2} \times \frac{7}{8}$	068H7162	068H5152
TDEZ 6	$\frac{1}{2} \times \frac{5}{8}$	068H7163	068H5184
TDEZ 6	$\frac{1}{2} \times \frac{7}{8}$	068H7164	068H5153
TDEZ 6	$\frac{5}{8} \times \frac{7}{8}$	068H7165	068H5154
TDEZ 7.5	$\frac{5}{8} \times \frac{7}{8}$	068H7166	068H5155

TDEBZ 8 - 19 Balanced port

TDEBZ 8	$\frac{5}{8} \times \frac{7}{8}$	068H7175	068H8122
TDEBZ 11	$\frac{5}{8} \times \frac{7}{8}$	068H7177	068H8124
TDEBZ 11	$\frac{5}{8} \times \frac{1}{8}$	068H7179	068H8126
TDEBZ 12.5	$\frac{5}{8} \times \frac{7}{8}$	068H7181	068H8128
TDEBZ 12.5	$\frac{5}{8} \times \frac{1}{8}$	068H7183	068H8130
TDEBZ 16	$\frac{5}{8} \times \frac{1}{8}$	068H7185	068H8132
TDEBZ 16	$\frac{7}{8} \times \frac{1}{8}$	068H7187	068H8134
TDEBZ 19	$\frac{7}{8} \times \frac{1}{8}$	068H7189	068H8136

TDEBZ 20 - 40 Balanced port

TDEBZ 20	$\frac{7}{8} \times \frac{1}{8}$	068H7191	068H8138
TDEBZ 26	$\frac{7}{8} \times \frac{3}{8}$	068H7193	068H8140
TDEBZ 30	$\frac{7}{8} \times \frac{3}{8}$	068H7195	068H8142
TDEBZ 30	$1\frac{1}{8} \times \frac{3}{8}$	068H7197	068H8144
TDEBZ 40	$1\frac{1}{8} \times \frac{3}{8}$	068H7199	068H8146

¹⁾ The rated capacity is based on:
 Evaporating temperature $t_e = 40^\circ\text{F}$
 Liquid temperature $t_l = 80^\circ\text{F}$
 Condensing temperature $t_c = 90^\circ\text{F}$

R407C

Range AC = 15 to 60°F with MOP 115 psig

Type and rated capacity ¹⁾ A × B TR	Connection solder ODF × ODF in.	Code no. Multipack	Code no. Industrial pack
--	---------------------------------------	-----------------------	-----------------------------

Range AC = 15 to 60°F with MOP 115 psig

Type and rated capacity ¹⁾ A × B TR	Connection solder ODF × ODF in.	Code no. Multipack	Code no. Industrial pack
--	---------------------------------------	-----------------------	-----------------------------

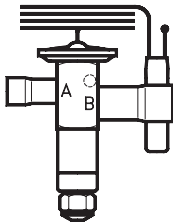
TDEZ 3 - 7.5 Single port

TDEZ 3	$\frac{3}{8} \times \frac{5}{8}$	068H7220	068H8148
TDEZ 3	$\frac{1}{2} \times \frac{5}{8}$	068H7221	068H8150
TDEZ 4	$\frac{1}{2} \times \frac{7}{8}$	068H7222	068H8152
TDEZ 6	$\frac{1}{2} \times \frac{5}{8}$	068H7223	068H8154
TDEZ 6	$\frac{1}{2} \times \frac{7}{8}$	068H7224	068H8156
TDEZ 6	$\frac{5}{8} \times \frac{7}{8}$	068H7225	068H8158
TDEZ 7.5	$\frac{5}{8} \times \frac{7}{8}$	068H7226	068H8160

TDEBZ 8 - 19 Balanced port

TDEBZ 8	$\frac{5}{8} \times \frac{7}{8}$	068H7235	068H8178
TDEBZ 11	$\frac{5}{8} \times \frac{7}{8}$	068H7237	068H8180
TDEBZ 11	$\frac{5}{8} \times \frac{1}{8}$	068H7239	068H8182
TDEBZ 12.5	$\frac{5}{8} \times \frac{7}{8}$	068H7241	068H8184
TDEBZ 12.5	$\frac{5}{8} \times \frac{1}{8}$	068H7243	068H8186
TDEBZ 16	$\frac{5}{8} \times \frac{1}{8}$	068H7245	068H8188
TDEBZ 16	$\frac{7}{8} \times \frac{1}{8}$	068H7247	068H8190
TDEBZ 19	$\frac{7}{8} \times \frac{1}{8}$	068H7249	068H8192

TDEBZ 20 - 40 Balanced port

TDEBZ 20	$\frac{7}{8} \times \frac{1}{8}$	068H7251	068H8194
TDEBZ 26	$\frac{7}{8} \times \frac{3}{8}$	068H7253	068H8196
TDEBZ 30	$\frac{7}{8} \times \frac{3}{8}$	068H7255	068H8198
TDEBZ 30	$1\frac{1}{8} \times \frac{3}{8}$	068H7257	068H8200
TDEBZ 40	$1\frac{1}{8} \times \frac{3}{8}$	068H7259	068H8202

¹⁾ The rated capacity is based on:
 Evaporating temperature $t_e = 40^\circ\text{F}$
 Liquid temperature $t_l = 80^\circ\text{F}$
 Condensing temperature $t_c = 90^\circ\text{F}$

Metric conversions

1 psi = 0.07 bar
 $\frac{5}{9}(t_1^\circ\text{F} - 32) = t_2^\circ\text{C}$
 1 ton = 3.5 kW
 1 in. = 25.4 mm

Ordering (continued)

R407C

Range N = -40 to 50°F

Type and rated capacity ¹⁾ A × B TR	Connection solder ODF × ODF in.	Code no. Multipack	Code no. Industrial pack
--	---	-----------------------	-----------------------------

Range N = -40 to 50°F

Type and rated capacity ¹⁾ A × B TR	Connection solder ODF × ODF in.	Code no. Multipack	Code no. Industrial pack
--	---	-----------------------	-----------------------------

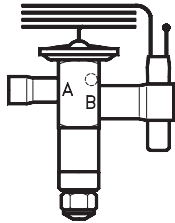
TDEZ 3 - 7.5 Single port

TDEZ 3	$\frac{3}{8} \times \frac{5}{8}$	068H7000	068H8204
TDEZ 3	$\frac{1}{2} \times \frac{5}{8}$	068H7002	068H8206
TDEZ 4	$\frac{1}{2} \times \frac{7}{8}$	068H7004	068H8208
TDEZ 6	$\frac{1}{2} \times \frac{5}{8}$	068H7006	068H8210
TDEZ 6	$\frac{1}{2} \times \frac{7}{8}$	068H7008	068H8212
TDEZ 6	$\frac{5}{8} \times \frac{7}{8}$	068H7010	068H8214
TDEZ 7.5	$\frac{5}{8} \times \frac{7}{8}$	068H7012	068H8216

TDEBZ 8 - 19 Balanced port

TDEBZ 8	$\frac{5}{8} \times \frac{7}{8}$	068H7014	068H8234
TDEBZ 11	$\frac{5}{8} \times \frac{7}{8}$	068H7016	068H8236
TDEBZ 11	$\frac{5}{8} \times 1\frac{1}{8}$	068H7018	068H8238
TDEBZ 12.5	$\frac{5}{8} \times \frac{7}{8}$	068H7020	068H8240
TDEBZ 12.5	$\frac{5}{8} \times 1\frac{1}{8}$	068H7022	068H8242
TDEBZ 16	$\frac{5}{8} \times 1\frac{1}{8}$	068H7024	068H8244
TDEBZ 16	$\frac{7}{8} \times 1\frac{1}{8}$	068H7026	068H8246
TDEBZ 19	$\frac{7}{8} \times 1\frac{1}{8}$	068H7028	068H8248

TDEBZ 20 - 40 Balanced port

TDEBZ 20	$\frac{7}{8} \times 1\frac{1}{8}$	068H7030	068H8250
TDEBZ 26	$\frac{7}{8} \times 1\frac{3}{8}$	068H7032	068H8252
TDEBZ 30	$\frac{7}{8} \times 1\frac{3}{8}$	068H7034	068H8254
TDEBZ 30	$1\frac{1}{8} \times 1\frac{3}{8}$	068H7036	068H8256
TDEBZ 40	$1\frac{1}{8} \times 1\frac{3}{8}$	068H7038	068H8258

¹⁾ The rated capacity is based on:
 Evaporating temperature $t_e = 40^\circ\text{F}$
 Liquid temperature $t_l = 80^\circ\text{F}$
 Condensing temperature $t_c = 90^\circ\text{F}$

Capacity

R22

Capacities in tons for range AC, K and N

Type and rated capacity in TR	Pressure drop across valve Δp psi								
	60	80	100	125	150	175	200	225	250

Evaporating temperature 60°F

TDEX 3	2.9	3.3	3.5	3.8	4.0	4.1	4.2	4.3	4.3
TDEX 4	3.4	4.4	4.7	5.1	5.3	5.5	5.7	5.8	5.8
TDEX 6	5.9	6.6	7.1	7.6	7.9	8.2	8.4	8.6	8.7
TDEX 7.5	7.4	8.2	8.9	9.5	9.9	10.3	10.5	10.7	10.8
TDEBX 8	7.5	8.4	9.0	9.7	10.2	10.5	10.8	11.0	11.1
TDEBX 11	10.5	11.7	12.6	13.5	14.1	14.7	15.0	15.3	15.4
TDEBX 12.5	12.1	13.4	14.5	15.5	16.2	16.8	17.2	17.5	17.7
TDEBX 16	15.6	17.3	19.2	19.9	20.9	21.5	22.1	22.5	22.8
TDEBX 19	18.6	20.7	22.2	23.8	24.9	25.8	26.3	26.8	27.1
TDEBX 20	19.4	21.5	23.2	24.9	26.1	26.9	27.6	28.1	28.4
TDEBX 26	25.3	28.0	30.2	32.4	33.9	35.1	35.9	36.4	36.9
TDEBX 30	29.4	32.7	35.2	37.8	39.5	40.8	41.8	42.5	43.0
TDEBX 40	39.1	43.5	46.9	50.0	52.3	54.1	55.4	56.3	56.8

Evaporating temperature 40°F

TDEX 3	2.5	2.7	2.9	3.1	3.3	3.4	3.5	3.5	3.6
TDEX 4	3.3	3.7	3.9	4.2	4.4	4.6	4.7	4.7	4.9
TDEX 6	4.9	5.5	5.9	6.3	6.6	6.8	6.9	7.1	7.1
TDEX 7.5	6.1	6.8	7.3	7.8	8.1	8.4	8.6	8.7	8.8
TDEBX 8	6.7	7.4	7.9	8.5	8.9	9.2	9.4	9.5	9.6
TDEBX 11	9.1	10.1	10.8	11.6	12.1	12.5	12.8	13.0	13.1
TDEBX 12.5	10.4	11.5	12.4	13.2	13.8	14.3	14.6	14.9	15.0
TDEBX 16	13.3	14.7	15.8	16.9	17.7	18.2	18.7	18.9	19.1
TDEBX 19	15.8	17.5	18.8	20.2	21.0	21.7	22.2	22.5	22.8
TDEBX 20	16.7	18.4	19.8	21.2	22.1	22.9	23.4	23.8	24.0
TDEBX 26	21.6	23.9	25.7	27.4	28.7	29.6	30.3	30.8	31.1
TDEBX 30	24.9	27.6	29.7	31.6	33.1	34.3	34.9	35.5	35.8
TDEBX 40	33.2	36.5	39.4	41.9	43.7	45.2	46.2	46.9	47.7

Evaporating temperature 20°F

TDEX 3	2.0	2.2	2.4	2.5	2.6	2.7	2.8	2.8	2.8
TDEX 4	2.7	2.9	3.2	3.3	3.5	3.6	3.7	3.7	3.8
TDEX 6	4.0	4.4	4.7	5.0	5.2	5.4	5.5	5.6	5.6
TDEX 7.5	4.9	5.4	5.8	6.2	6.4	6.6	6.8	6.8	6.9
TDEBX 8	5.8	6.4	6.8	7.3	7.6	7.8	8.0	8.1	8.2
TDEBX 11	7.7	8.5	9.1	9.7	10.1	10.4	10.7	10.8	10.9
TDEBX 12.5	8.8	9.7	10.4	11.0	11.5	11.8	12.1	12.3	12.4
TDEBX 16	11.0	12.2	13.1	13.9	14.5	14.9	15.2	15.5	15.6
TDEBX 19	13.1	14.4	15.5	16.4	17.1	17.7	18.0	18.3	18.4
TDEBX 20	14.0	15.4	16.5	17.6	18.3	18.9	19.3	19.5	19.8
TDEBX 26	17.9	18.8	21.2	22.5	23.5	24.2	24.8	25.1	25.3
TDEBX 30	20.5	22.5	24.2	25.7	26.8	27.7	28.2	28.6	28.9
TDEBX 40	27.1	29.9	31.9	34.0	35.4	36.5	37.2	37.7	38.0

Type and rated capacity in TR	Pressure drop across valve Δp psi								
	60	80	100	125	150	175	200	225	250

Evaporating temperature 50°F

TDEX 3	2.7	3.0	3.2	3.5	3.6	3.7	3.8	3.9	4.0
TDEX 4	3.6	4.0	4.3	4.6	4.9	5.1	5.2	5.3	5.3
TDEX 6	5.4	6.0	6.5	6.9	7.3	7.5	7.7	7.8	7.9
TDEX 7.5	6.8	7.5	8.1	8.6	9.0	9.3	9.6	9.7	9.8
TDEBX 8	7.1	7.9	8.5	9.1	9.5	9.8	10.1	10.2	10.4
TDEBX 11	9.8	10.9	11.7	12.5	13.1	13.6	13.9	14.1	14.3
TDEBX 12.5	11.3	12.5	13.4	14.4	15.0	15.6	15.9	16.2	16.4
TDEBX 16	14.4	16.0	17.3	18.4	19.3	19.9	20.4	20.7	20.9
TDEBX 19	17.2	19.1	20.6	21.9	23.0	23.7	24.3	24.6	24.9
TDEBX 20	18.0	20.0	21.5	23.0	24.1	25.0	25.5	25.6	26.2
TDEBX 26	23.4	26.0	28.0	29.9	31.3	32.3	33.1	33.7	33.9
TDEBX 30	27.2	30.2	32.4	34.6	36.4	37.5	38.4	39.0	39.4
TDEBX 40	36.1	40.1	43.1	46.0	48.1	49.7	50.8	51.6	52.1

Evaporating temperature 30°F

TDEX 3	2.2	2.5	2.6	2.8	2.9	3.0	3.1	3.2	3.2
TDEX 4	3.0	3.3	3.5	3.8	3.9	4.1	4.2	3.7	3.8
TDEX 6	4.5	4.9	5.3	5.6	5.9	6.1	6.2	6.3	6.4
TDEX 7.5	5.5	6.1	6.5	6.9	7.3	7.5	7.7	7.8	7.9
TDEBX 8	6.2	6.9	7.4	7.9	8.2	8.5	8.7	8.8	8.9
TDEBX 11	8.4	9.3	10.0	10.6	11.1	11.5	11.7	11.9	12.0
TDEBX 12.5	9.6	10.6	11.4	12.1	12.7	13.1	13.4	13.5	13.7
TDEBX 16	12.2	13.5	14.4	15.4	16.0	16.6	16.9	17.2	17.3
TDEBX 19	14.4	16.0	17.1	18.2	19.0	19.6	20.1	20.4	20.5
TDEBX 20	15.3	16.9	18.2	19.3	20.2	20.9	21.4	21.7	21.9
TDEBX 26	19.7	21.8	23.5	24.9	26.0	26.9	27.5	27.9	28.1
TDEBX 30	22.7	25.0	26.9	28.7	29.9	30.9	31.4	32.0	32.3
TDEBX 40	30.1	33.3	35.6	37.8	39.5	40.8	41.6	42.2	42.6

Correction for subcooling Δt_{sub}

The evaporator capacity used must be corrected if the subcooling deviates from 10°F.

The corrected capacity can be obtained by multiplying the required evaporator capacity by the correction factor given below, and then selecting from the tables.

Note: Insufficient subcooling can produce flash gas.

Δt_{sub}	10°F	20°F	30°F	40°F	50°F	60°F
Correction factor	1.00	0.94	0.89	0.85	0.81	0.78

The capacities are based on:

Condensing temperature

$t_c = 110^\circ\text{F}$

Liquid temperature ahead of expansion valve

$t_l = 100^\circ\text{F}$

Capacity (continued)

R22

Capacities in tons for range AC, K and N

Type and rated capacity in TR	Pressure drop across valve Δp psi								
	60	80	100	125	150	175	200	225	250

Evaporating temperature 15°F									
TDEX 3	1.9	2.1	2.2	2.3	2.5	2.5	2.6	2.6	2.6
TDEX 4	2.5	2.8	3.0	3.1	3.3	3.4	3.5	3.5	3.5
TDEX 6	3.7	4.1	4.4	4.7	4.9	5.1	5.2	5.2	5.3
TDEX 7.5	4.6	5.1	5.4	5.8	6.0	6.2	6.3	6.4	6.5
TDEBX 8	5.6	6.2	6.6	7.0	7.3	7.5	7.7	7.8	7.9
TDEBX 11	7.4	8.1	8.7	9.3	9.7	9.9	10.2	10.3	10.4
TDEBX 12.5	8.4	9.2	9.9	10.5	10.9	11.2	11.5	11.7	11.8
TDEBX 16	10.5	11.6	12.4	13.2	13.7	14.1	14.4	14.6	14.7
TDEBX 19	12.4	13.7	14.7	15.6	16.2	16.7	17.1	17.3	17.4
TDEBX 20	13.3	14.7	15.7	16.7	17.5	18.0	18.4	18.7	18.8
TDEBX 26	17.0	18.8	20.1	21.3	22.3	22.9	23.4	23.7	23.9
TDEBX 30	19.4	21.4	22.9	24.3	25.3	26.1	26.6	27.0	27.2
TDEBX 40	25.7	28.3	30.4	32.1	33.4	34.4	35.1	35.6	35.8

Evaporating temperature 0°F									
TDEX 3	1.5	1.7	1.8	1.9	2.0	2.1	2.1	2.1	2.1
TDEX 4	2.1	2.3	2.4	2.6	2.7	2.7	2.8	2.8	2.9
TDEX 6	3.1	3.4	3.6	3.8	4.0	4.1	4.2	4.2	4.3
TDEX 7.5	3.7	4.1	4.4	4.7	4.9	5.0	5.1	5.2	5.2
TDEBX 8	5.0	5.5	5.8	6.2	6.5	6.6	6.8	6.9	6.9
TDEBX 11	6.4	7.0	7.5	8.0	8.3	8.5	8.7	8.8	8.9
TDEBX 12.5	7.2	7.9	8.5	9.0	9.3	9.6	9.8	9.9	10.0
TDEBX 16	8.9	9.8	10.5	11.1	11.5	11.9	12.1	12.3	12.3
TDEBX 19	10.5	11.6	12.4	13.1	13.6	14.0	14.3	14.4	14.5
TDEBX 20	11.5	12.6	13.5	14.3	14.9	15.3	15.6	15.8	15.9
TDEBX 26	14.5	15.9	17.0	18.0	18.7	19.3	19.6	19.9	20.0
TDEBX 30	16.3	17.9	19.1	20.3	21.1	21.7	22.1	22.4	22.5
TDEBX 40	21.5	23.7	25.2	26.6	27.7	28.5	29.1	29.4	29.6

Evaporating temperature -15°F									
TDEX 3	1.2	1.4	1.4	1.5	1.6	1.6	1.7	1.7	1.7
TDEX 4	1.6	1.8	1.9	2.0	2.1	2.2	2.2	2.2	2.3
TDEX 6	2.5	2.7	2.9	3.0	3.2	3.3	3.3	3.4	3.4
TDEX 7.5	3.0	3.3	3.5	3.7	3.9	4.0	4.0	4.1	4.1
TDEBX 8	4.4	4.8	5.2	5.5	5.7	5.8	5.9	6.0	6.0
TDEBX 11	5.5	6.1	6.4	6.8	7.1	7.3	7.4	7.5	7.5
TDEBX 12.5	6.1	6.7	7.2	7.6	7.9	8.1	8.2	8.3	8.4
TDEBX 16	7.5	8.2	8.7	9.2	9.6	9.8	10.0	10.1	10.2
TDEBX 19	8.8	9.6	10.3	10.8	11.3	11.6	11.8	11.8	12.0
TDEBX 20	9.8	10.7	11.4	12.1	12.5	12.9	13.1	13.3	13.3
TDEBX 26	12.1	13.3	14.2	14.9	15.5	16.0	16.2	16.4	16.5
TDEBX 30	13.5	14.8	15.8	16.7	17.3	17.8	18.1	18.3	18.4
TDEBX 40	17.7	19.4	20.7	21.8	22.7	23.3	23.7	24.0	24.0

Pressure drop across valve Δp psi									
60	80	100	125	150	175	200	225	250	250

Evaporating temperature 10°F									
1.8	1.9	2.1	2.2	2.3	2.4	2.4	2.5	2.5	2.5
2.4	2.6	2.8	2.9	3.1	3.2	3.2	3.3	3.3	3.3
3.5	3.9	4.2	4.4	4.6	4.7	4.8	4.9	4.9	4.9
4.3	4.8	5.1	5.4	5.6	5.8	5.9	6.0	6.0	6.0
5.4	5.9	6.3	6.7	7.0	7.2	7.4	7.5	7.5	7.5
7.0	7.8	8.3	8.8	9.2	9.5	9.7	9.8	9.8	9.8
8.0	8.8	9.4	10.0	10.4	10.7	10.9	11.1	11.1	11.1
10.0	11.0	11.8	12.4	13.0	13.4	13.6	13.8	13.9	13.9
11.8	13.0	13.9	14.7	15.3	15.7	16.1	16.3	16.4	16.4
12.7	14.0	14.9	15.9	16.6	17.0	17.4	17.6	17.8	17.8
16.1	17.8	19.0	20.1	21.1	21.7	22.1	22.4	22.6	22.6
18.3	20.2	21.6	22.9	23.9	24.6	25.1	25.4	25.5	25.5
24.2	26.7	28.5	30.2	31.5	32.4	33.0	33.5	33.7	33.7

Evaporating temperature -10°F									
1.3	1.5	1.6	1.7	1.7	1.8	1.8	1.8	1.8	1.8
1.8	2.0	2.1	2.2	2.3	2.4	2.4	2.4	2.4	2.5
2.7	2.9	3.1	3.3	3.4	3.5	3.6	3.6	3.7	3.7
3.3	3.6	3.8	4.0	4.2	4.3	4.4	4.4	4.5	4.5
4.6	5.0	5.4	5.7	5.9	6.1	6.2	6.3	6.3	6.3
5.8	6.4	6.8	7.2	7.5	7.7	7.8	7.9	8.0	8.0
6.5	7.1	7.6	8.0	8.3	8.6	8.7	8.8	8.9	8.9
7.9	8.7	9.3	9.8	10.2	10.5	10.7	10.8	10.9	10.9
9.4	10.3	10.9	11.6	12.0	12.3	12.6	12.7	12.8	12.8
10.3	11.3	12.1	12.8	13.3	13.6	13.9	14.1	14.2	14.2
12.9	14.1	15.1	15.9	16.6	17.0	17.3	17.5	17.7	17.7
14.4	15.8	16.9	17.8	18.5	19.0	19.4	19.6	19.7	19.7
18.9	20.8	22.1	23.4	24.3	25.0	25.4	25.7	25.8	25.8

Correction for subcooling Δt_{sub}
 The evaporator capacity used must be corrected if the subcooling deviates from 10°F.

The corrected capacity can be obtained by multiplying the required evaporator capacity by the correction factor given below, and then selecting from the tables.

Note: Insufficient subcooling can produce flash gas.

Δt_{sub}	10°F	20°F	30°F	40°F	50°F	60°F
Correction factor	1.00	0.94	0.89	0.85	0.81	0.78

The capacities are based on:
 Condensing temperature $t_c = 110^\circ\text{F}$
 Liquid temperature ahead of expansion valve $t_l = 100^\circ\text{F}$

Capacity (continued)

R22

Capacities in tons for range AC, K and N

Type and rated capacity in TR	Pressure drop across valve Δp psi								
	60	80	100	125	150	175	200	225	250

Evaporating temperature -20°F

TDEX 3	1.1	1.3	1.3	1.4	1.5	1.5	1.5	1.5	1.6
TDEX 4	1.5	1.7	1.8	1.9	2.0	2.0	2.0	2.1	2.1
TDEX 6	2.3	2.5	2.7	2.8	2.9	3.0	3.1	3.1	3.1
TDEX 7.5	2.8	3.1	3.3	3.4	3.6	3.7	3.7	3.8	3.8
TDEBX 8	4.2	4.6	5.0	5.2	5.4	5.6	5.7	5.7	5.8
TDEBX 11	5.2	5.7	6.1	6.5	6.7	6.9	7.0	7.1	7.1
TDEBX 12.5	5.8	6.4	6.8	7.2	7.4	7.6	7.8	7.8	7.9
TDEBX 16	7.0	7.7	8.2	8.7	9.0	9.2	9.4	9.5	9.5
TDEBX 19	8.3	9.0	9.6	10.1	10.5	10.8	11.0	11.1	11.2
TDEBX 20	9.2	10.1	10.8	11.4	11.8	12.1	12.4	12.5	12.6
TDEBX 26	11.4	12.5	13.3	14.0	14.6	14.9	15.2	15.4	15.5
TDEBX 30	12.6	13.8	14.7	15.5	16.2	16.6	16.9	17.0	17.1
TDEBX 40	16.6	18.1	19.3	20.4	21.1	21.7	22.0	22.3	22.4

Evaporating temperature -40°F

TDEX 3	0.8	0.9	0.9	1.0	1.0	1.1	1.1	1.1	1.1
TDEX 4	1.1	1.2	1.3	1.3	1.4	1.4	1.4	1.4	1.4
TDEX 6	1.6	1.8	1.9	2.0	2.1	2.1	2.1	2.2	2.2
TDEX 7.5	2.0	2.2	2.3	2.4	2.5	2.6	2.6	2.6	2.6
TDEBX 8	3.6	4.0	4.2	4.4	4.6	4.7	4.8	4.8	4.8
TDEBX 11	4.3	4.6	4.9	5.2	5.4	5.5	5.6	5.7	5.7
TDEBX 12.5	4.6	5.1	5.4	5.7	5.9	6.0	6.1	6.1	6.2
TDEBX 1	5.4	5.9	6.3	6.6	6.9	7.0	7.1	7.2	7.2
TDEBX 19	6.3	6.9	7.3	7.7	8.0	8.2	8.3	8.4	8.4
TDEBX 20	7.4	8.0	8.5	9.0	9.3	9.5	9.7	9.7	9.8
TDEBX 26	8.8	9.6	10.2	10.7	11.1	11.4	11.6	11.7	11.7
TDEBX 30	9.6	10.4	11.1	11.6	12.1	12.3	12.5	12.7	12.7
TDEBX 40	12.4	13.5	14.4	15.1	15.7	16.0	16.3	16.4	16.5

Pressure drop across valve Δp psi								
60	80	100	125	150	175	200	225	250

Evaporating temperature -30°F

1.0	1.1	1.1	1.2	1.2	1.3	1.3	1.3	1.3
1.3	1.4	1.5	1.6	1.6	1.7	1.7	1.7	1.7
1.9	2.1	2.3	2.4	2.5	2.5	2.6	2.6	2.6
2.4	2.6	2.7	2.9	3.0	3.1	3.1	3.2	3.2
3.9	4.3	4.6	4.8	5.0	5.1	5.2	5.3	5.3
4.7	5.2	5.5	5.8	6.0	6.2	6.3	6.3	6.4
5.2	5.7	6.0	6.4	6.6	6.8	6.9	7.0	7.0
6.2	6.8	7.2	7.6	7.9	8.1	8.2	8.3	8.3
7.3	7.9	8.4	8.9	9.2	9.4	9.6	9.7	9.7
8.3	9.0	9.6	10.1	10.5	10.8	10.9	11.1	11.1
10.0	11.0	11.7	12.3	12.7	13.1	13.3	13.4	13.5
11.0	12.0	12.8	13.5	14.0	14.3	14.6	14.7	14.8
14.4	15.7	16.7	17.6	18.2	18.8	19.0	19.2	19.3

The capacities are based on:
 Condensing temperature $t_c = 110^\circ\text{F}$
 Liquid temperature ahead of expansion valve $t_l = 100^\circ\text{F}$

Correction for subcooling Δt_{sub}

Correction for subcooling Δt_{sub}

The evaporator capacity used must be corrected if the subcooling deviates from 10°F.

The corrected capacity can be obtained by multiplying the required evaporator capacity by the correction factor given below, and then selecting from the tables.

Note: Insufficient subcooling can produce flash gas.

Δt_{sub}	10°F	20°F	30°F	40°F	50°F	60°F
Correction factor	1.00	0.94	0.89	0.85	0.81	0.78

Capacity (continued)

R407C

Capacities in tons for range AC, K and N

Type and rated capacity in TR	Pressure drop across valve Δp psi								
	60	80	100	125	150	175	200	225	250

Evaporating temperature 60°F									
TDEZ 3	3.0	3.4	3.6	3.8	3.9	4.0	4.1	4.1	4.1
TDEZ 4	4.1	4.5	4.8	5.1	5.3	5.4	5.5	5.6	5.6
TDEZ 6	6.1	6.7	7.2	7.6	7.9	8.1	8.2	8.3	8.2
TDEZ 7.5	7.6	8.4	9.0	9.5	9.9	10.1	10.3	10.3	10.3
TDEBZ 8	7.8	8.6	9.2	9.8	10.1	10.4	10.5	10.6	10.6
TDEBZ 11	10.9	12.0	12.8	13.6	14.1	14.4	14.6	14.7	14.7
TDEBZ 12.5	12.5	13.8	14.8	15.6	16.2	16.6	16.8	16.9	16.9
TDEBZ 16	16.1	17.8	19.0	20.1	20.8	21.3	21.6	21.7	21.6
TDEBZ 19	19.2	21.2	22.7	23.9	24.8	25.4	25.7	25.8	25.8
TDEBZ 20	20.0	22.1	23.7	25.1	26.0	26.6	27.0	27.1	27.1
TDEBZ 26	26.1	28.8	30.8	32.6	33.8	34.8	35.1	35.2	35.2
TDEBZ 30	30.4	33.5	36.0	37.8	39.4	40.3	40.8	41.1	40.9
TDEBZ 40	40.4	44.6	47.6	50.3	52.5	53.3	53.9	54.2	54.0

Evaporating temperature 40°F									
TDEZ 3	2.5	2.8	3.0	3.2	3.3	3.4	3.4	3.4	3.4
TDEZ4	3.4	3.8	4.0	4.2	4.4	4.5	4.6	4.6	4.6
TDEZ 6	5.1	5.6	6.0	6.3	6.6	6.7	6.8	6.8	6.8
TDEZ 7.5	6.3	7.0	7.4	7.8	8.1	8.3	8.4	8.4	8.4
TDEBZ 8	6.9	7.6	8.1	8.5	8.9	9.0	9.2	9.2	9.2
TDEBZ 11	9.4	10.3	11.0	11.7	12.1	12.3	12.5	12.5	12.5
TDEBZ 12.5	10.8	11.8	12.6	13.3	13.8	14.1	14.3	14.3	14.3
TDEBZ 16	13.7	15.1	16.1	17.0	17.6	17.9	18.2	18.2	18.2
TDEBZ 19	16.4	18.0	19.2	20.2	20.9	21.3	21.5	21.7	21.6
TDEBZ 20	17.2	18.9	20.2	21.3	22.1	22.6	22.8	22.9	22.9
TDEBZ 26	22.3	24.5	26.2	27.6	28.6	29.2	29.5	29.6	29.5
TDEBZ 30	25.7	28.3	30.2	31.8	33.0	33.6	34.1	34.2	34.0
TDEBZ 40	34.3	37.5	40.0	42.1	43.6	44.4	44.5	45.0	45.0

Evaporating temperature 20°F									
TDEZ 3	2.0	2.2	2.4	2.5	2.6	2.6	2.7	2.7	2.7
TDEZ4	2.7	3.0	3.2	3.4	3.5	3.5	3.6	3.6	3.6
TDEZ 6	4.1	4.5	4.8	5.0	5.2	5.3	5.3	5.3	5.3
TDEZ 7.5	5.0	5.5	5.9	6.2	6.4	6.5	6.6	6.6	6.5
TDEBZ 8	6.0	6.5	6.9	7.3	7.6	7.7	7.8	7.8	7.8
TDEBZ 11	7.9	8.7	9.2	9.7	10.1	10.2	10.3	10.4	10.3
TDEBZ 12.5	9.0	9.9	10.5	11.0	11.4	11.6	11.7	11.8	11.7
TDEBZ 16	11.4	12.4	13.2	13.9	14.3	14.6	14.8	14.8	14.7
TDEBZ 19	13.5	14.8	15.7	16.4	17.0	17.3	17.5	17.5	17.4
TDEBZ 20	14.4	15.7	16.7	17.6	18.2	18.6	18.7	18.8	18.7
TDEBZ 26	18.4	20.2	21.5	22.5	23.3	23.8	24.0	24.0	23.9
TDEBZ 30	21.1	23.1	24.5	25.7	26.6	27.1	27.4	27.4	27.3
TDEBZ 40	27.9	30.4	32.4	34.0	35.0	35.7	36.0	36.0	35.9

Pressure drop across valve Δp psi								
60	80	100	125	150	175	200	225	250

Evaporating temperature 50°F								
2.8	3.1	3.3	3.5	3.6	3.7	3.8	3.8	3.8
3.8	4.1	4.4	4.7	4.9	5.0	5.0	5.1	5.1
5.6	6.2	6.6	7.0	7.2	7.4	7.5	7.5	7.5
7.0	7.7	8.2	8.7	9.0	9.2	9.3	9.4	9.4
7.3	8.1	8.7	9.2	9.5	9.7	9.9	9.9	9.9
10.1	11.2	12.0	12.6	13.1	13.4	13.6	13.7	13.6
11.6	12.8	13.7	14.5	15.0	15.4	15.6	15.6	15.6
14.9	16.4	17.6	18.6	19.3	19.7	19.9	20.0	19.9
17.8	19.7	20.7	22.1	22.9	23.4	23.7	23.8	23.7
18.6	20.5	21.9	23.2	24.0	24.6	24.9	25.0	25.0
24.3	26.7	28.5	30.2	31.2	31.9	32.2	32.5	32.4
28.1	31.0	33.1	35.1	36.2	37.0	37.4	37.6	37.6
37.3	41.1	43.9	46.3	47.9	48.1	49.5	49.7	49.5

Evaporating temperature 30°F								
2.3	2.5	2.7	2.8	2.9	3.0	3.0	3.0	3.0
3.1	3.4	3.6	3.8	3.9	4.0	4.1	4.1	4.1
4.6	5.0	5.4	5.7	5.9	6.0	6.1	6.1	6.1
5.7	6.2	6.6	7.0	7.2	7.4	7.5	7.5	7.5
6.4	7.0	7.5	7.9	8.2	8.4	8.5	8.5	8.5
8.7	9.5	10.1	10.7	11.1	11.3	11.4	11.4	11.4
9.9	10.9	11.6	12.2	12.6	12.8	13.0	13.0	13.0
12.6	13.8	14.7	15.4	16.0	16.3	16.5	16.5	16.4
14.9	16.3	17.4	18.3	18.9	19.3	19.5	19.5	19.5
15.8	17.3	18.5	19.5	20.1	20.5	20.8	20.8	20.8
20.4	22.4	23.8	25.1	25.9	26.4	26.7	26.9	26.7
23.4	25.7	27.3	28.8	29.9	30.3	30.7	30.7	30.6
31.0	34.0	36.1	38.0	39.3	40.0	40.4	40.1	40.3

Correction for subcooling Δt_{sub}
 The evaporator capacity used must be corrected if the subcooling deviates from 10°F.

The corrected capacity can be obtained by multiplying the required evaporator capacity by the correction factor given below, and then selecting from the tables.

Note: Insufficient subcooling can produce flash gas.

Δt_{sub}	10°F	20°F	30°F	40°F	50°F	60°F
Correction factor	1.00	0.94	0.89	0.85	0.81	0.78

The capacities are based on:
 Condensing temperature $t_c = 110^\circ\text{F}$
 Liquid temperature ahead of expansion valve $t_l = 100^\circ\text{F}$

Capacity (continued)

R407C

Capacities in tons for range AC, K and N

Type and rated capacity in TR	Pressure drop across valve Δp psi								
	60	80	100	125	150	175	200	225	250

Evaporating temperature 15°F

TDEZ 3	1.9	2.1	2.2	2.4	2.4	2.5	2.5	2.5	2.5
TDEZ 4	2.6	2.8	3.0	3.1	3.2	3.3	3.3	3.3	3.3
TDEZ 6	3.9	4.2	4.5	4.7	4.8	4.9	5.0	5.0	5.0
TDEZ 7.5	4.7	5.2	5.5	5.8	6.0	6.1	6.1	6.1	6.1
TDEBZ 8	5.7	6.3	6.7	7.0	7.2	7.4	7.5	7.5	7.4
TDEBZ 11	7.6	8.3	8.8	9.3	9.6	9.7	9.8	9.9	9.8
TDEBZ 12.5	8.6	9.4	10.0	10.5	10.8	11.0	11.1	11.1	11.1
TDEBZ 16	10.8	11.8	12.5	13.2	13.6	13.8	14.0	14.0	13.9
TDEBZ 19	12.8	14.0	14.8	15.6	16.0	16.3	16.5	16.5	16.4
TDEBZ 20	13.7	15.0	15.9	16.7	17.3	17.5	17.8	17.8	17.7
TDEBZ 26	17.5	19.1	20.3	21.3	22.0	22.4	22.6	22.7	22.6
TDEBZ 30	20.0	21.8	23.1	24.3	25.0	25.6	25.7	25.8	25.6
TDEBZ 40	26.3	28.9	30.5	32.0	33.0	33.6	33.9	33.9	33.7

Evaporating temperature 0°F

TDEZ 3	1.6	1.7	1.8	1.9	2.0	2.0	2.0	2.0	2.0
TDEZ 4	2.1	2.3	2.4	2.5	2.6	2.7	2.7	2.7	2.7
TDEZ 6	3.1	3.4	3.6	3.8	3.9	4.0	4.0	4.0	4.0
TDEZ 7.5	3.8	4.2	4.4	4.6	4.8	4.9	4.9	4.9	4.9
TDEBZ 8	5.1	5.5	5.9	6.2	6.3	6.5	6.5	6.5	6.5
TDEBZ11	6.5	7.1	7.6	7.9	8.2	8.3	8.4	8.4	8.3
TDEBZ 12.5	7.3	8.0	8.5	8.9	9.2	9.3	9.4	9.4	9.3
TDEBZ 16	9.1	9.9	10.5	11.0	11.3	11.5	11.6	11.7	11.5
TDEBZ 19	10.8	11.7	12.4	13.0	13.3	13.6	13.7	13.7	13.6
TDEBZ 20	11.7	12.8	13.5	14.2	14.6	14.9	15.0	15.0	14.9
TDEBZ 26	14.8	16.1	17.0	17.9	18.4	18.7	18.8	18.8	18.7
TDEBZ 30	16.7	18.1	19.2	20.1	20.7	21.0	21.1	21.2	21.0
TDEBZ 40	22.0	23.9	25.3	26.4	27.2	27.6	27.8	27.8	27.6

Evaporating temperature -15°F

TDEZ 3	1.2	1.4	1.4	1.5	1.5	1.6	1.6	1.6	1.6
TDEZ 4	1.7	1.8	1.9	2.0	2.1	2.1	2.1	2.1	2.1
TDEZ 6	2.5	2.7	2.9	3.0	3.1	3.1	3.1	3.1	3.1
TDEZ 7.5	3.1	3.3	3.5	3.7	3.8	3.8	3.8	3.8	3.8
TDEBZ 8	4.5	4.9	5.2	5.4	5.5	5.6	5.7	5.6	5.6
TDEBZ 11	5.6	6.1	6.4	6.7	6.9	7.0	7.0	7.0	7.0
TDEBZ 12.5	6.2	6.8	7.1	7.5	7.7	7.8	7.8	7.8	7.7
TDEBZ 16	7.6	8.2	8.7	9.0	9.3	9.4	9.5	9.4	9.4
TDEBZ 19	8.9	9.7	10.2	10.6	10.9	11.1	11.1	11.1	11.0
TDEBZ 20	9.9	10.8	11.4	11.9	12.2	12.4	12.4	12.4	12.3
TDEBZ 26	12.3	13.3	14.1	14.7	15.1	15.3	15.4	15.4	15.3
TDEBZ 30	13.7	14.8	15.7	16.4	16.8	17.0	17.1	17.1	17.0
TDEBZ 40	17.9	19.4	20.5	21.4	22.0	22.3	22.4	22.4	22.2

Type and rated capacity in TR	Pressure drop across valve Δp psi								
	60	80	100	125	150	175	200	225	250

Evaporating temperature 10°F

1.8	2.0	2.1	2.2	2.3	2.3	2.3	2.3	2.3	2.3
2.4	2.6	2.8	2.9	3.0	3.1	3.1	3.1	3.1	3.1
3.6	3.9	4.2	4.4	4.5	4.6	4.7	4.7	4.7	4.6
4.4	4.8	5.1	5.4	5.6	5.7	5.7	5.7	5.7	5.7
5.5	6.0	6.4	6.7	6.9	7.1	7.1	7.1	7.1	7.1
7.2	7.9	8.4	8.8	9.1	9.2	9.3	9.3	9.3	9.3
8.2	8.9	9.5	9.9	10.3	10.4	10.5	10.5	10.5	10.5
10.2	11.1	11.8	12.4	12.8	13.0	13.1	13.1	13.1	13.1
12.1	13.2	14.0	14.7	15.1	15.4	15.5	15.5	15.5	15.4
13.0	14.2	15.1	15.9	16.4	16.6	16.8	16.8	16.8	16.7
16.6	18.1	19.2	20.2	20.8	21.2	21.3	21.3	21.3	21.2
18.8	20.5	21.8	22.9	23.5	24.0	24.2	24.2	24.2	24.0
24.8	27.1	28.7	30.1	31.0	31.5	31.8	31.8	31.8	31.6

Evaporating temperature -10°F

1.4	1.5	1.6	1.6	1.7	1.7	1.7	1.7	1.7	1.7
1.8	2.0	2.1	2.2	2.2	2.3	2.3	2.3	2.3	2.3
2.7	2.9	3.1	3.3	3.3	3.4	3.4	3.4	3.4	3.4
3.3	3.6	3.8	4.0	4.1	4.1	4.2	4.2	4.2	4.1
4.7	5.1	5.4	5.6	5.8	5.9	5.9	5.9	5.9	5.9
5.9	6.4	6.8	7.1	7.3	7.4	7.5	7.5	7.5	7.4
6.6	7.2	7.6	7.9	8.1	8.3	8.3	8.3	8.3	8.3
8.1	8.8	9.3	9.7	10.0	10.1	10.2	10.2	10.2	10.1
9.5	10.3	10.9	11.4	11.7	11.9	11.9	11.9	11.9	11.8
10.5	11.4	12.1	12.6	13.0	13.2	13.3	13.3	13.3	13.1
13.1	14.2	15.1	15.7	16.1	16.4	16.5	16.5	16.5	16.4
14.6	15.8	16.8	17.5	18.0	18.3	18.4	18.4	18.4	18.3
19.2	20.7	21.9	23.0	23.6	24.0	24.1	24.1	24.1	24.0

Correction for subcooling Δt_{sub}

The evaporator capacity used must be corrected if the subcooling deviates from 10°F.

The corrected capacity can be obtained by multiplying the required evaporator capacity by the correction factor given below, and then selecting from the tables.

Note: Insufficient subcooling can produce flash gas.

Δt_{sub}	10°F	20°F	30°F	40°F	50°F	60°F
Correction factor	1.00	0.94	0.89	0.85	0.81	0.78

The capacities are based on:

Condensing temperature

$t_c = 110^\circ\text{F}$

Liquid temperature ahead of expansion valve

$t_l = 100^\circ\text{F}$

Capacity (continued)

R407C

Capacities in tons for range AC, K and N

Type and rated capacity in TR	Pressure drop across valve Δp psi								
	60	80	100	125	150	175	200	225	250

Evaporating temperature –20°F

TDEZ 3	1.2	1.2	1.3	1.4	1.4	1.4	1.4	1.4	1.4
TDEZ 4	1.5	1.7	1.8	1.8	1.9	1.9	1.9	1.9	1.9
TDEZ 6	2.3	2.5	2.6	2.8	2.8	2.9	2.9	2.9	2.9
TDEZ 7.5	2.8	3.0	3.2	3.4	3.4	3.5	3.5	3.5	3.5
TDEBZ 8	4.3	4.7	4.9	5.1	5.3	5.4	5.4	5.4	5.3
TDEBZ 11	5.3	5.8	6.1	6.3	6.5	6.6	6.6	6.6	6.6
TDEBZ 12.5	5.9	6.4	6.7	7.0	7.2	7.3	7.3	7.3	7.3
TDEBZ 16	7.1	7.7	8.1	8.5	8.7	8.8	8.9	8.8	8.8
TDEBZ 19	8.3	9.0	9.5	9.9	10.2	10.3	10.4	10.4	10.3
TDEBZ 20	9.3	10.1	10.7	11.2	11.5	11.6	11.7	11.7	11.6
TDEBZ 26	11.5	12.5	13.2	13.7	14.1	14.3	14.4	14.3	14.2
TDEBZ 30	12.7	13.8	14.6	15.2	15.6	15.8	15.9	15.9	15.7
TDEBZ 40	16.7	18.1	19.1	19.9	20.4	20.7	20.8	20.7	20.5

Type and rated capacity in TR	Pressure drop across valve Δp psi								
	60	80	100	125	150	175	200	225	250

Evaporating temperature –30°F

TDEZ 3	1.0	1.0	1.1	1.2	1.2	1.2	1.2	1.2	1.2
TDEZ 4	1.3	1.4	1.5	1.5	1.6	1.6	1.6	1.6	1.6
TDEZ 6	1.9	2.1	2.2	2.3	2.4	2.4	2.4	2.4	2.4
TDEZ 7.5	2.4	2.6	2.7	2.8	2.9	2.9	2.9	2.9	2.9
TDEBZ 8	4.0	4.3	4.5	4.7	4.8	4.9	4.9	4.9	4.8
TDEBZ 11	4.8	5.1	5.4	5.6	5.8	5.9	5.9	5.9	5.8
TDEBZ 12.5	5.2	5.6	5.9	6.2	6.4	6.4	6.5	6.4	6.4
TDEBZ 16	6.2	6.7	7.1	7.4	7.5	7.6	7.7	7.6	7.6
TDEBZ 19	7.3	7.9	8.3	8.6	8.8	8.9	9.0	8.9	8.8
TDEBZ 20	8.3	9.0	9.4	9.9	10.1	10.3	10.3	10.2	10.1
TDEBZ 26	10.1	10.9	11.5	11.9	12.2	12.4	12.4	12.4	12.3
TDEBZ 30	11.0	12.0	12.6	13.1	13.4	13.6	13.6	13.6	13.5
TDEBZ 40	14.4	15.6	16.4	17.0	17.4	17.7	17.7	17.7	17.5

Evaporating temperature –40°F

TDEZ 3	0.8	0.9	0.9	1.0	1.0	1.0	1.0	1.0	1.0
TDEZ 4	1.1	1.2	1.2	1.3	1.3	1.3	1.3	1.3	1.3
TDEZ 6	1.6	1.7	1.8	1.9	1.9	2.0	2.0	2.0	1.9
TDEZ 7.5	2.0	2.1	2.2	2.3	2.4	2.4	2.4	2.4	2.4
TDEBZ 8	3.6	3.9	4.1	4.3	4.4	4.4	4.5	4.4	4.4
TDEBZ 11	4.2	4.6	4.8	5.0	5.1	5.2	5.2	5.2	5.1
TDEBZ 12.5	4.6	5.0	5.2	5.5	5.6	5.6	5.7	5.6	5.6
TDEBZ 16	5.4	5.8	6.1	6.4	6.5	6.6	6.6	6.6	6.5
TDEBZ 19	6.3	6.8	7.1	7.4	7.6	7.7	7.7	7.7	7.6
TDEBZ 20	7.4	7.9	8.3	8.7	8.9	9.0	9.0	9.0	8.9
TDEBZ 26	8.8	9.4	9.9	10.3	10.6	10.7	10.7	10.7	10.6
TDEBZ 30	9.5	10.2	10.8	11.2	11.5	11.6	11.6	11.6	11.4
TDEBZ 40	12.3	13.3	14.0	14.5	14.8	15.0	15.0	15.0	14.8

The capacities are based on:
 Condensing temperature $t_c = 110^\circ\text{F}$
 Liquid temperature ahead of expansion valve $t_l = 100^\circ\text{F}$

Correction for subcooling Δt_{sub}

Correction for subcooling Δt_{sub}

The evaporator capacity used must be corrected if the subcooling deviates from 10°F.

The corrected capacity can be obtained by multiplying the required evaporator capacity by the correction factor given below, and then selecting from the tables.

Note: Insufficient subcooling can produce flash gas.

Δt_{sub}	10°F	20°F	30°F	40°F	50°F	60°F
Correction factor	1.00	0.94	0.89	0.85	0.81	0.78

Design and function

The TD valve series is designed with straight through ODF solder connections, a fixed orifice, and a thermostatic element.

Two push pins in non-friction stuffing boxes connect the power assembly with the orifice.

Port design

1. Bulb with capillary tube
2. Thermostatic element
3. Thrust pad
4. Valve body
5. Throttling cone assembly
6. Adjustment spindle
7. Adjustment spindle assembly
8. Protective cap

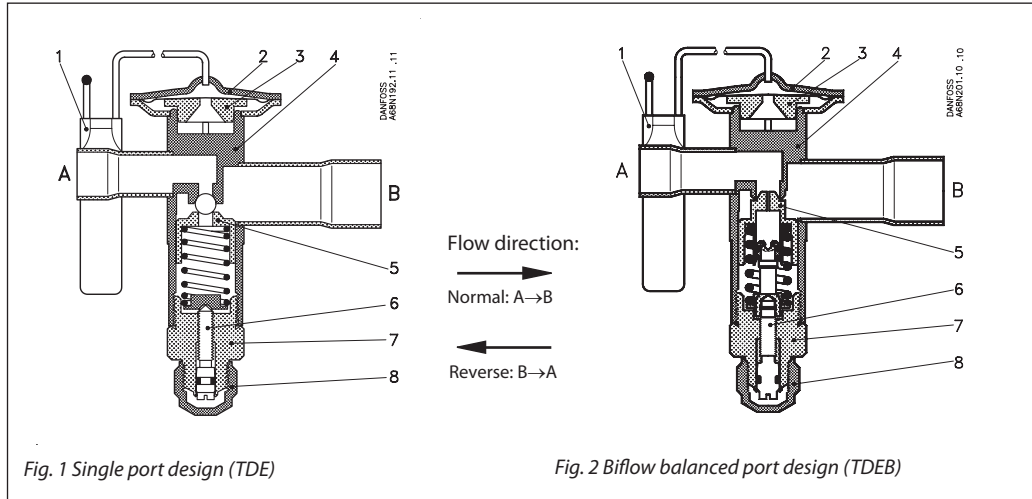

In an expansion valve, there are three main forces that influence operation: bulb pressure, spring pressure, and evaporating pressure, which together define the power balance for the valve. As the required capacity increases, in turn requiring greater orifice area, there is potential for condensing pressure to adversely influence the power balance.

To eliminate condensing pressure influence, a balanced port design is used. The Danfoss TD series of thermostatic expansion valves includes both single port and balanced port designs.

The single port design, fig. 1, is used in smaller capacities (from 3.5 to 7 TR R22) where the potential for condensing pressure influence is negligible.

The balanced port design, fig.2, is used in larger capacities (from 8 to 40 TR R22), where influence of condensing pressure can adversely affect control.

The TDEB's balanced port design functions as illustrated in fig. 3.

The condensing pressure enters through the pilot port into the pressure balance chamber, where

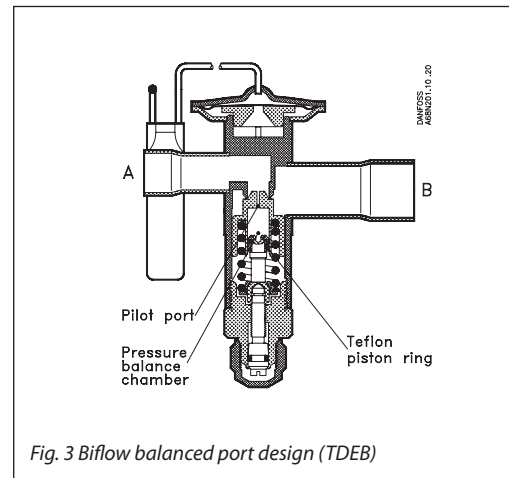

it is neutralized by acting on equal and opposite areas. The Danfoss design is unique in that the balanced port function is also maintained during reverse flow, making the TDEB valve ideal for bi-flow applications.

Application

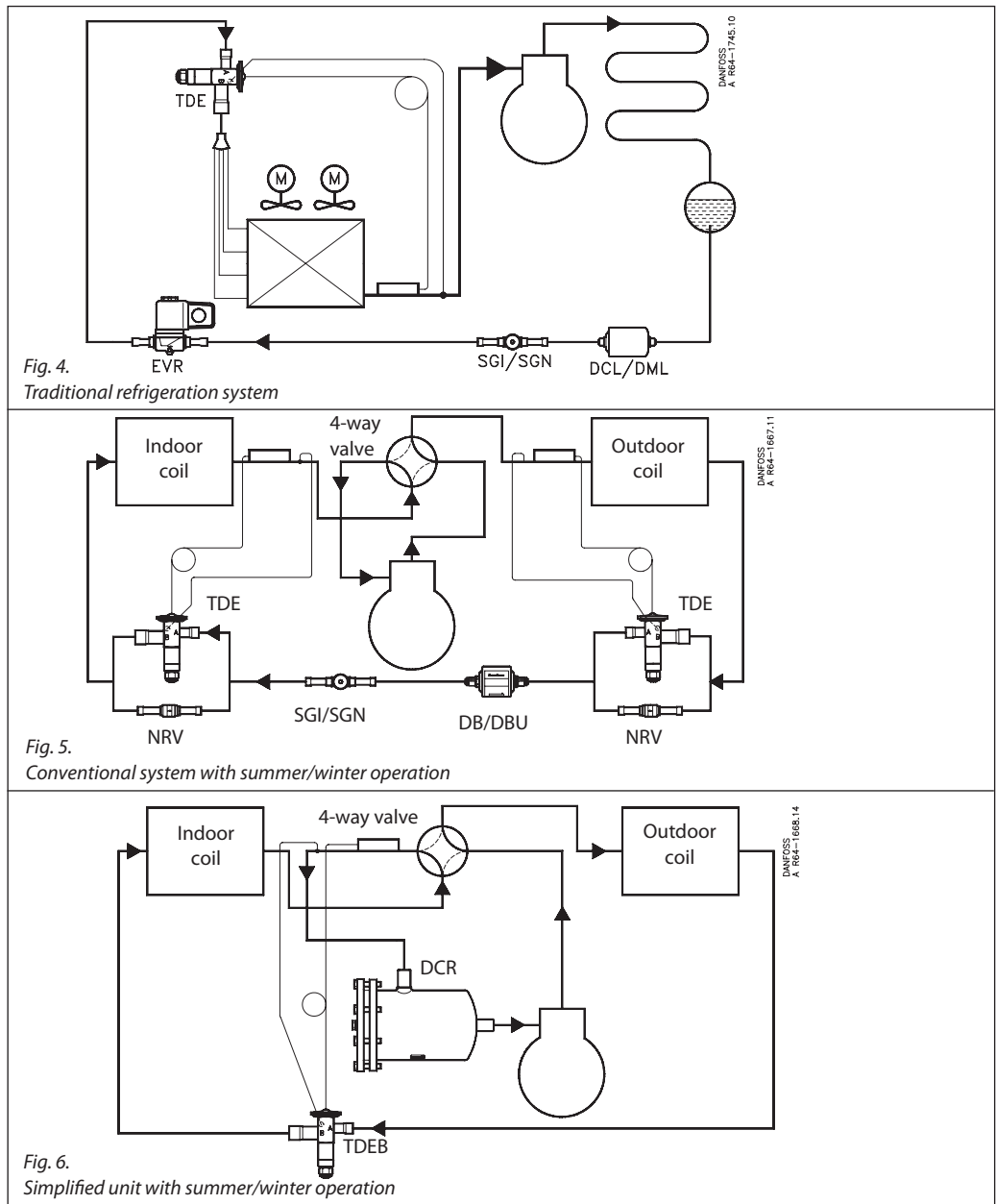

Fig. 4. Traditional refrigeration system

Fig. 5. Conventional system with summer/winter operation

Fig. 6. Simplified unit with summer/winter operation

Fig. 4 is a diagram of a traditional refrigeration system where the TDE valve is used for flow in one direction.

Fig. 5 is a conventional split air conditioning/heat pump system with cooling/heating operation and two expansion valves with fixed direction of flow. The system shown is in cooling mode and requires two thermostatic expansion valves, e.g. TDE, and two NRV check valves. Sight glass type SGI/SGN can be placed in the line before the TDE. Changeover between cooling and heating is performed via a 4-way solenoid valve.

Fig. 6 is similar to the previous system but as a self contained unit with a short distance between evaporator and condenser. The system is also shown in cooling mode.

The two expansion valves have been replaced by one TDEB biflow valve. Check valves are not required. Changeover is by means of a 4-way valve. The normal flow direction of TDEB is determined by the primary function, i.e. cooling or heating.

Operation and function

MOP - Maximum Operating Pressure

MOP function protects the compressor motor against overload during start-up. MOP is the evaporating pressure at which the expansion valve will throttle liquid injection into the evaporator and thus prevent the evaporating pressure from rising. MOP valves are primarily used in low temperature applications with a single evaporator and a single compressor. MOP occurs when the sensor reaches a predetermined maximum value. Above MOP any increase in sensor temperature results in only minimal additional opening of the expansion valve. An MOP charge is also known as a pressure limiting charge.

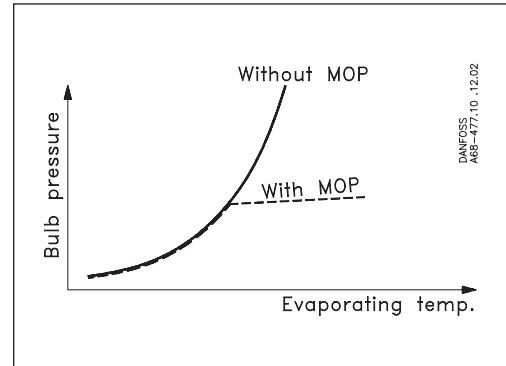

Note! The MOP point will change if the factory superheat setting of the expansion valve is changed. If the superheat setting increases, the MOP point is reduced and vice versa, if the MOP point increases, the superheat setting is reduced.

Subcooling Δt_{sub}

Subcooling is defined as the difference between the liquid refrigerant temperature and its saturation temperature. Depending on system design, subcooling may be necessary to prevent flash gas from forming in the liquid line. If flash gas forms in the liquid line, the capacity of the expansion valve will be greatly reduced.

Superheat-subcooling relationship

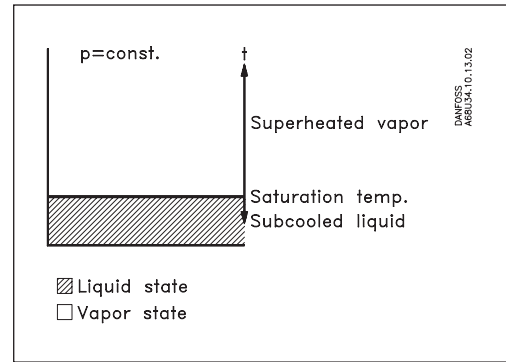

Superheat

Superheat is the controlling parameter of the valve. Superheat, measured at the evaporator outlet, is defined as the difference between actual bulb temperature and the evaporating temperature at the saturation point. In other words, vapor is said to be superheated if its temperature is higher than the saturation temperature corresponding to its pressure. In order to prevent liquid refrigerant from entering the compressor, a certain minimum superheat must be maintained. Liquid entering the compressor causes serious damage. When discussing superheat, the following terms are used with respect to valve operation:

Static Superheat

Static superheat, SS, is the superheat above which the valve will begin to open.

Opening Superheat

The opening superheat, OS, is the amount of superheat above the static superheat, SS, required to produce a given valve capacity.

Operating superheat

The operating superheat, SH, is the sum of the static superheat, SS, and the opening superheat, OS.

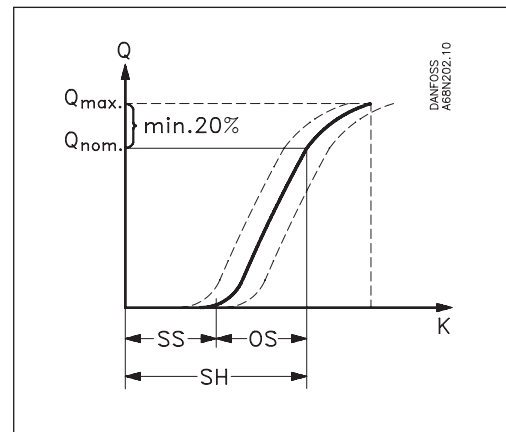

Identification

Essential valve data is given on the element label, fig. 7.

- Example, fig. 1*
- TDEX = Type (X: refrigerant R22)
 - 8 TR = Rated capacity Q_{nom} in Tons of Refrigeration
 - 28 kW = Rated capacity Q_{nom} in kW
 - R22 = Refrigerant
 - 25/+10 °C = Evaporating temperature range (°C)
 - 15/+50 °F = Evaporating temperature range (°F)
 - 068H4112 = Code number
 - BP 15 = Bleed 15 %
 - MOP 100 = Max. Operation Pressure
 - PB 28 bar/ MWP 400 psig = Max. working pressure
 - 288 = Date marking (week 28, 1998)

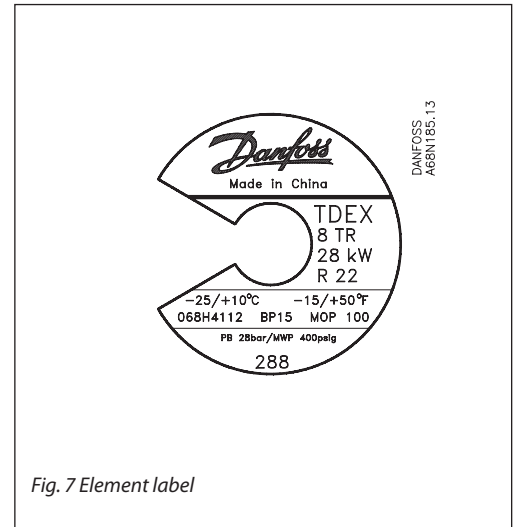
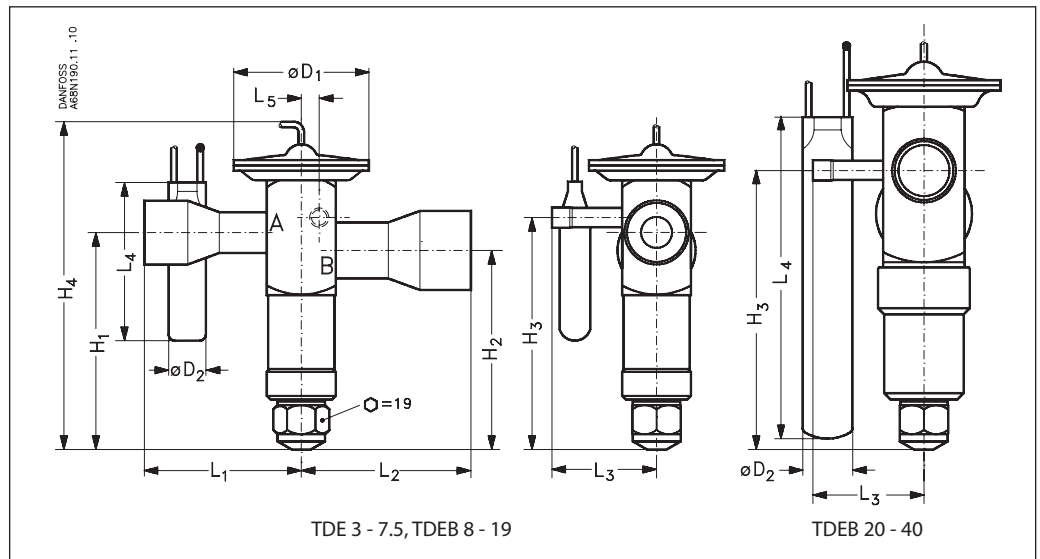

Fig. 7 Element label

Dimensions and weights



Type	Connection ODF solder inlet × outlet in.	Capillary tube length ft	H ₁ in.	H ₂ in.	H ₃ in.	H ₄ in.	L ₁ in.	L ₂ in.	L ₃ in.	L ₄ in.	L ₅ in.	ØD ₁ in.	ØD ₂ in.	Weight lbs.
TDE 3 - 7.5	$\frac{3}{8} \times \frac{5}{8}$	5	2.776	2.539	2.933	4.606	1.614	1.732	1.516	2.441	0.197	1.772	0.551	0.9
	$\frac{1}{2} \times \frac{5}{8}$	5	2.776	2.539	2.933	4.606	1.633	1.732	1.516	2.441	0.197	1.772	0.551	0.9
	$\frac{1}{2} \times \frac{7}{8}$	5	2.776	2.539	2.933	4.606	1.633	2.323	1.516	2.441	0.197	1.772	0.551	0.9
	$\frac{5}{8} \times \frac{7}{8}$	5	2.776	2.539	2.933	4.606	1.732	2.323	1.516	2.441	0.197	1.772	0.551	0.9
TDEB 8 - 19	$\frac{5}{8} \times \frac{7}{8}$	5	3.346	3.071	3.583	5.394	1.831	2.421	1.614	2.441	0.276	2.087	0.551	1.3
	$\frac{5}{8} \times 1 \frac{1}{8}$	5	3.346	3.071	3.583	5.394	1.831	2.618	1.614	2.441	0.276	2.087	0.551	1.3
	$\frac{7}{8} \times 1 \frac{1}{8}$	5	3.346	3.071	3.583	5.394	2.421	2.618	1.614	2.441	0.276	2.087	0.551	1.3
TDEB 20 - 40	$\frac{7}{8} \times 1 \frac{1}{8}$	10	4.311	3.642	4.311	6.693	2.500	2.697	1.713	4.961	0.394	2.362	0.748	2.4
	$\frac{7}{8} \times 1 \frac{3}{8}$	10	4.311	3.642	4.311	6.693	2.500	2.894	1.713	4.961	0.394	2.362	0.748	2.4
	$1 \frac{1}{8} \times 1 \frac{3}{8}$	10	4.311	3.642	4.311	6.693	2.697	2.894	1.713	4.961	0.394	2.362	0.748	2.4

ISO 9001 quality approval



Refrigeration and Air Conditioning Controls, part of the Danfoss concern, is certified in accordance with international standard ISO 9001. This means that Danfoss fulfils the international standard in respect of product development, design, production and sale.