

# Oil Burner Controls type BHO 64 and LOA 44

Catalogue

5



## Contents

Application .....	page 2
Design .....	page 2
Variants and Application .....	page 2
Functions BHO 64A, 64, 64.1 .....	page 3
Measuring of Flame Sensing Current .....	page 4
Terminal Ratings .....	page 5
Technical Data .....	page 5
Base, Code no .....	page 6
Electrical Connections .....	page 7
Code Numbers and Function-Times .....	page 8
Dimensions .....	page 9
Adapter .....	page 10

**Quality and environmental management system**

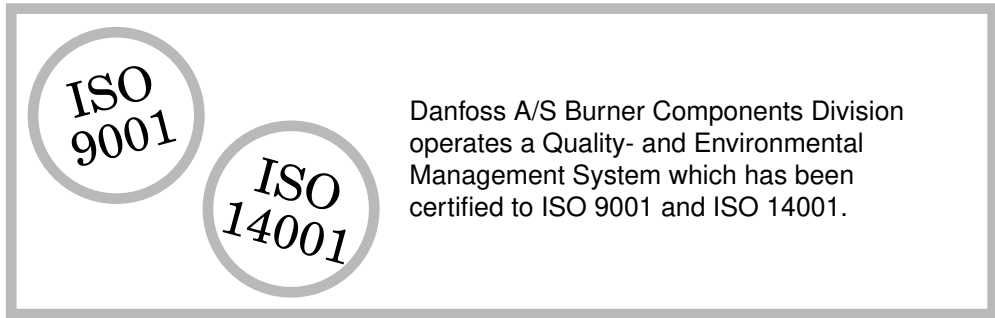

**Application**

The BHO series is for use with photo unit type LD or LDS on oil burners with intermittent operation in accordance with DIN 4787 and ISO 3544.

BHO 64A, 64, and 64.1 are for oil burners with a capacity of up to 30 kg/h.

LOA 44 is for oil burners with a capacity higher than 30 kg/h and hot air units.

All types can be used on single and two-stage burners.

All types meet the undervoltage protection requirements of ISO 3544 and European standard E 230.

**Design**

All oil burner controls are based on the familiar bimetal principle which controls burner start. An electronic amplifier adapts the current from the photo unit. Photo unit LD/LDS is designed to monitor yellow-flame oil burners.

The controls consist of an upper part which houses the function elements named above and a base that contains all electrical connection facilities.

There is a plug connection between the upper part and base. They are held together by a spring system.

The two parts can be separated by inserting a screwdriver down in the side slots in the upper part. See fig. 4 page 6.

**Variants and application**

The BHO series is for use with single or two-stage burners with prepurge, pre-ignition and post-ignition.

BHO 64 is for burners with preheater where burner-start is conditional on the preheater thermostat, but continued burner operation is not conditional on the preheater thermostat.

BHO 64 supersedes BHO 61 and BHO 62 and is thus used as a replacement of these units.

BHO 64.1 has shorter prepurge and pre-ignition than BHO 64, otherwise they are identical.

BHO 64A gives the option of short or long post-ignition. The design of the F-circuit gives a changed flame signal (min. 35  $\mu$ A).

LAO 44 is for use with oil burners (yellow-flame) with a capacity greater than 30 kg/h, and with hot air units.

LAO 44 is for use when replacing BHO 25 (new base), BHO 1 WLE and BHOV 1 WLE. Use adapter BHA 11/12. (Old type photo resistors must be replaced with new ones).

**Symbols**

In this catalogue the following symbols are used to explain the electrical function diagrams.

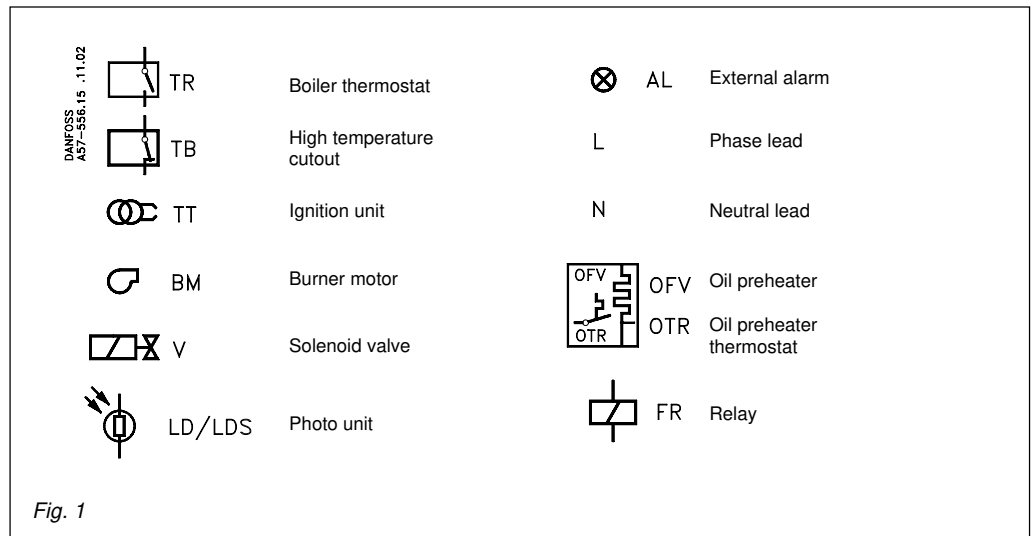

**Function**

BHO 64A, 64, 64.1, LOA 44

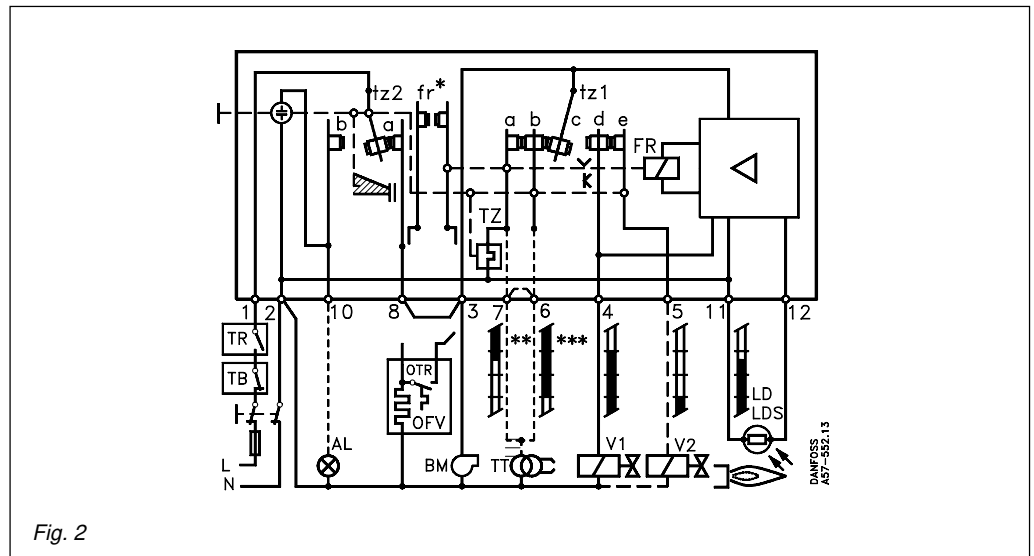

**Normal start**

When thermostat TR makes, voltage is applied to terminal 1. If no oil preheater is used, terminals 8 and 3 must be linked. If there is an oil preheater, it receives voltage via terminal 8. When the preheater thermostat, OTR, makes the connection to terminal 3, the burner motor starts. At the same time the control timer circuit (bimetal heating element) receives voltage via contact set tz1 and pre-purge time with pre-ignition (terminals 6/7) starts. After prepurge time, contact set tz1 changes over so that contacts d-e break and c-d make. This cuts in valve 1 via terminal 4. When the flame is established, relay FR pulls in thereby breaking contacts a-b.

The bimetal heating element TZ is thus cut out and the programme begins to cool down. At the same time, contact fr makes to ensure continued operation of the burner if the preheater thermostat breaks.

When relay FR pulls in, a locking arm holds contacts c-d closed. When the bimetal has cooled down, the programme will have returned to its initial position where contacts a-b break and ignition is cut out.

At the same time contacts d-e make so that valve 2 receives voltage via terminal 5.

**False light at start**

In the event of false light, relay FR pulls in and the locking arm prevents contacts c-d from making. Therefore heating of the bimetal continues until contact set tz2 changes over from position a to position b.

The system is thus blocked and there is voltage on alarm terminal 10. The control can only be reconnected when the bimetal has cooled down – after a minimum of 50 s. The sensitivity of the flame circuit is increased during prepurge time.

**No flame at start**

If no flame is established when contact set tz1 makes contacts c-d, relay FR does not pull in and the control blocks when safety lockout time elapses.

**Flame failure during operation**

If the flame fails during operation, relay FR drops out and instantaneously cuts off voltage to the oil valves. The control immediately begins a new start with prepurge and pre-ignition. If the flame is not established before the safety lockout time elapses, the control blocks.

If flame failure occurs in the interval between when valve V1 and valve V2 cut in, the flame relay drops out and the control tries to restart, i.e. there is still voltage on 4 and terminal 6/7.

**Undervoltage protection**

Undervoltage-protected controls incorporate an extra electronic circuit that protects the unit if dangerous undervoltage (<165 V) blocks burner start. No oil is released and the safety switch cuts out the burner.

If undervoltage occurs in an operating period, the burner will run its period of operation until the thermostat cuts out. Restart is not possible for as long as undervoltage persists.

**Measurement of current through photo unit**

**Measurement of current through photo unit**

The photo current is measured with a direct current ammeter in series with the photo unit (+ pole on terminal 12. Max. 5 kΩ internal resistance in measuring instrument).

The photo current must be between 65 μA and 200 μA at 220 V and 75 μA and 220 μA at 240 V.

With no flame, the measured photo current must be 5μA at 220 V and 6μA at 240 V.

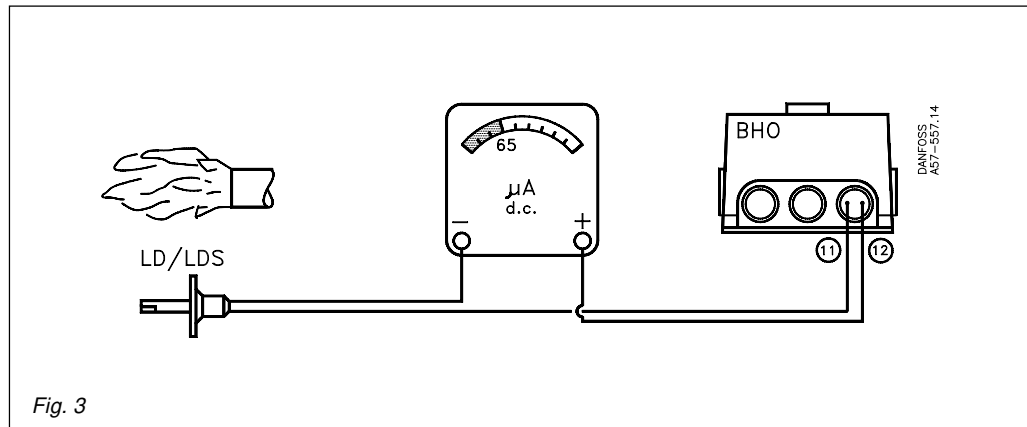

Fig. 3

**BHO 64A min. 35 μA**  
**BHO / 64.1 /LOA 44 min. 65 μA**

**Terminal rating**

Terminal	Max. operating current	Comments
1	5 A	Max. current applied
3	5 A	Incl. burner motor and preheater
4	1 A	Without solenoid valve max. 4 A
5	1 A	
6/7	2 A	
8	5 A	
10	1 A	

Technical data

Rated voltage *)	220/240 V~
Operating range *)	187-264 V~
Frequency	50-60 Hz $\pm$ 6%
Consumption	Approx. 3 VA
Reset	After min. 50 s
Reaction time on flame failure	Max. 1 s
Mains fuse	Max. 10 A
Cable connection, page 6	Plate for five Pg 11 screwed cable entries Plate with knockouts
Ambient temperature	-20 to +60 °C
Installation	Any position
Enclosure	IP 40
Flame monitoring	Photo unit LD or LDS
Max. cable length between BHO and LD/LDS	20 m (installed separately)
Sensitivity with photo unit during operation	LD : average 6 lux. Better than 20 lux LDS : average 2 lux. Better than 3 lux
Min.photo current during operation**) } Max. photo current <u>without</u> flame } BHO 64/ 64.1 LOA 44	65 $\mu$ A at 220 V, 75 $\mu$ A at 240 V 5 $\mu$ A at 220 V, 6 $\mu$ A at 240 V
Min.photo current during operation**) } Max. photo current <u>without</u> flame } BHO 64	35 $\mu$ A at 220 V, 40 $\mu$ A at 240 V 5 $\mu$ A at 220 V, 6 $\mu$ A at 240 V
Ambient temperature LD/LDS	-20 to +70°C

\*) See types and code numbers, page 8

\*\*) Max. 5 k $\Omega$  internal resistance in measuring instrument

**Base**

The base has 12 terminals which accept the plug connector in the control upper part. In addition it is fitted with:

- Three extra neutral terminals connected to terminal 2.
- Four internally connected earth terminals for connection direct to the burner housing via a grounding plate.
- Two loop terminals marked 31 and 32.
- Two Ø5.4 holes for fixing the base to the burner.

Two different front plates are available for the base, both with knockouts:

- 057H7011 for cable entry with cable relief
- 057H7012 for screwed cable entries.

The upper part and base are kept together by a spring system. The upper part can be removed by pressing a screwdriver down into the slot, see fig. 4.

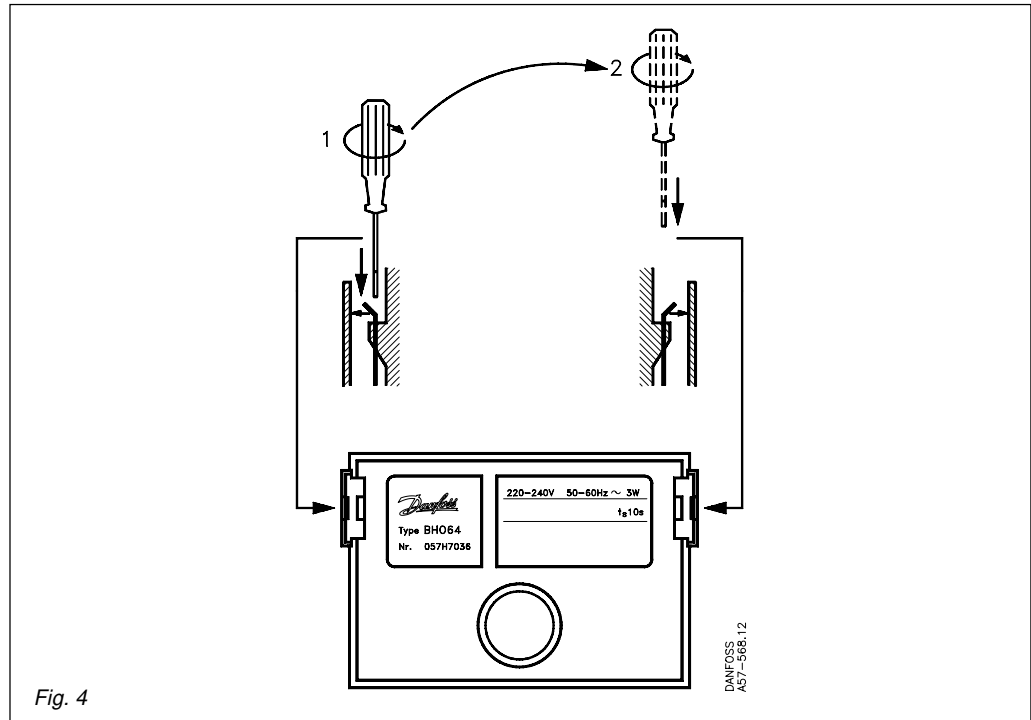

**Miscellaneous**

Description	Type	Code no.	Comments
Base		<b>057H7010</b>	
Frontplate <sup>1)</sup>		<b>057H7011</b>	For five Pg 11 screwed cable entries
Frontplate <sup>1)</sup>		<b>057H7012</b>	Side holes : One Ø 8.8 mm/Ø 17.5 mm Front holes : Three Ø 7 mm + oval 6x20 mm
Adapter <sup>2)</sup>	BHA 11/12	<b>057H7020</b>	For service market

<sup>1)</sup> Replaceable front plate, with knockouts.  
<sup>2)</sup> For service market.

Electrical Connections

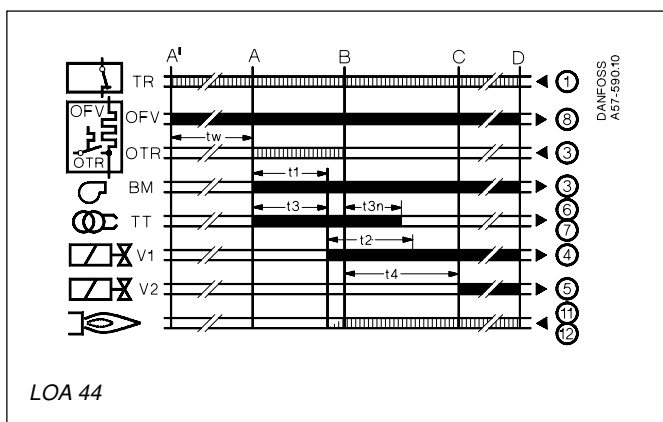
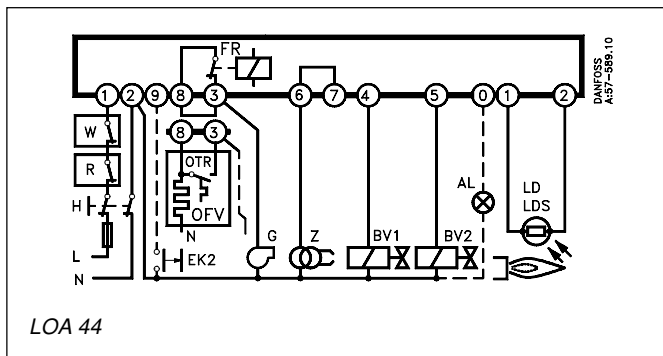
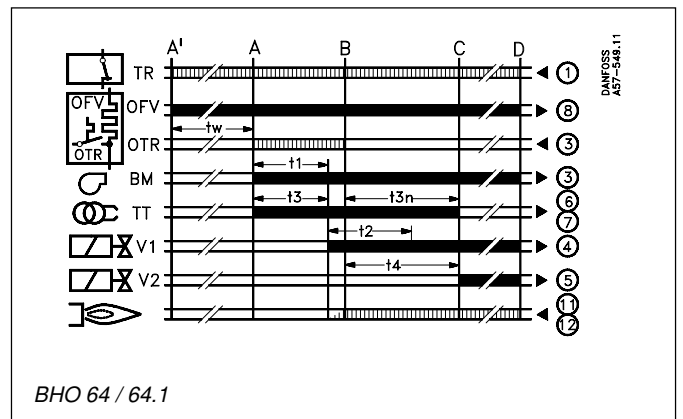
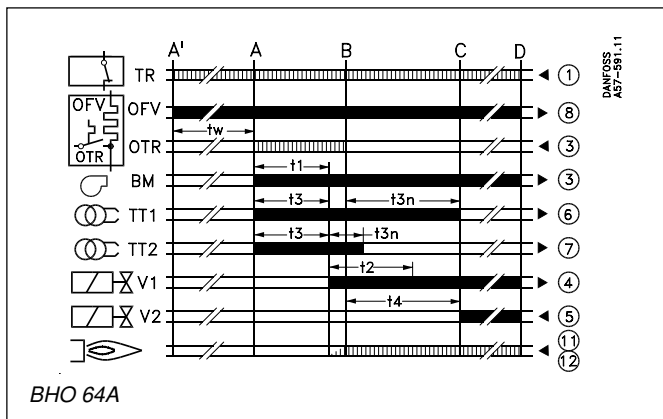
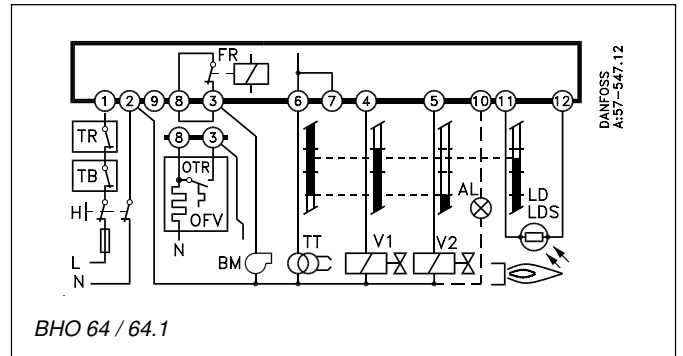
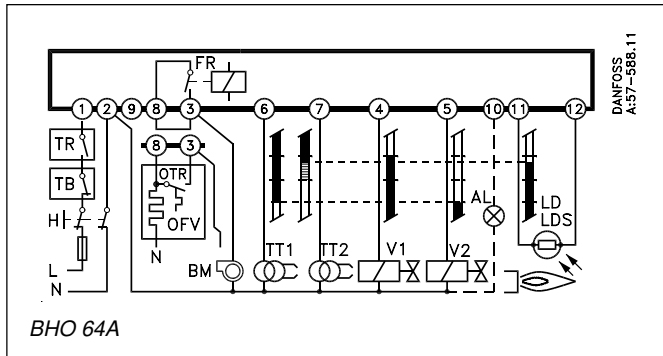

Code numbers

Controls

Type	Code no.	Rated voltage V	Function Times (s)				
			Under-voltage protection	Prepurge t1* t3	Post-ignition t3n	Interval V1-V2 t4	Safety lockout time t2 max.
BHO 64A	<b>057H7030</b>	220/240	x	13	** 2/15	15	10
BHO 64	<b>057H7036</b>	220/240	x	13	15	15	10
BHO 64.1	<b>057H7037</b>	220/240	x	6	20	20	10
LOA 44	<b>057H7040</b>	220/240	x	25	2	5	5

\* Purge time and pre-ignition time are the same.  
 \*\* BHO 64A has post-ignition as an option  
 terminal 6 gives 15 s  
 terminal 7 gives 2 s

Photo units

Description	Type	Code no.	Cable length L [mm]	Comments	Colour
Photo unit	LD	<b>057H7079</b>	780	<sup>5)</sup> Long housing Normal sensitivity	Black
Photo unit	LD	<b>057H7080</b>	270	<sup>5)</sup> Standard housing Normal sensitivity	Black
Photo unit	LD	<b>057H7081</b>	500	<sup>5)</sup> Standard housing Normal sensitivity	Black
Photo unit	LD	<b>057H7082</b>	800	<sup>5)</sup> Standard housing Normal sensitivity	Black
Photo unit	LD	<b>057H7083</b>	2000	<sup>5)</sup> Standard housing Normal sensitivity	Black
Photo unit	LDS	<b>057H7084</b>	270	<sup>5)</sup> Standard housing High sensitivity	Red
Photo unit	LDS	<b>057H7085</b>	500	<sup>5)</sup> Standard housing High sensitivity	Red
Photo unit	LDS	<b>057H7086</b>	270	<sup>5)</sup> Long housing High sensitivity	Red
Photo unit	LDS	<b>057H7087</b>	520	<sup>5)</sup> Long housing High sensitivity	Red
Photo unit	LDS	<b>057H7090</b>	700	<sup>5)</sup> Standard housing High sensitivity	Red
Photo unit	LDS	<b>057H7091</b>	350	<sup>5)</sup> Standard housing High sensitivity	Red
Photo unit	LDS	<b>057H7092</b>	800	<sup>5)</sup> Standard housing High sensitivity	Red
Photo unit	LDS	<b>057H7093</b>	500	<sup>5)</sup> Long housing extra High sensitivity	Light blue
Photo unit	LDS	<b>057H7094</b>	500	<sup>5)</sup> Long housing extra High sensitivity	Light blue
Photo unit	LDS	<b>057H7095</b>	800	Special housing High sensitivity	Red
Photo unit	LDS	<b>057H7100</b>	270	High sensitivity spec. type – long housing (QRB1S)	Red

Flange		<b>057H7070</b>			
Flange		<b>057H7071</b>			
Clamping ring		<b>057H7072</b>			

<sup>5)</sup> See page 9.  
 Basepart, see page 6.

Accessories

Service kit – code no. 057H7022 – contains the following components:

Description	Code no.	Comments
BHA 11/12	<b>057H7020</b>	Adapter
Photo unit	<b>057H7087</b>	Elongated housing and high light sensitivity
Flange	<b>057H7071</b>	As the old LD photo unit
Clamping ring	<b>057H7072</b>	



**Dimensions  
BHO**

Control with base  
Front plate 057H7011

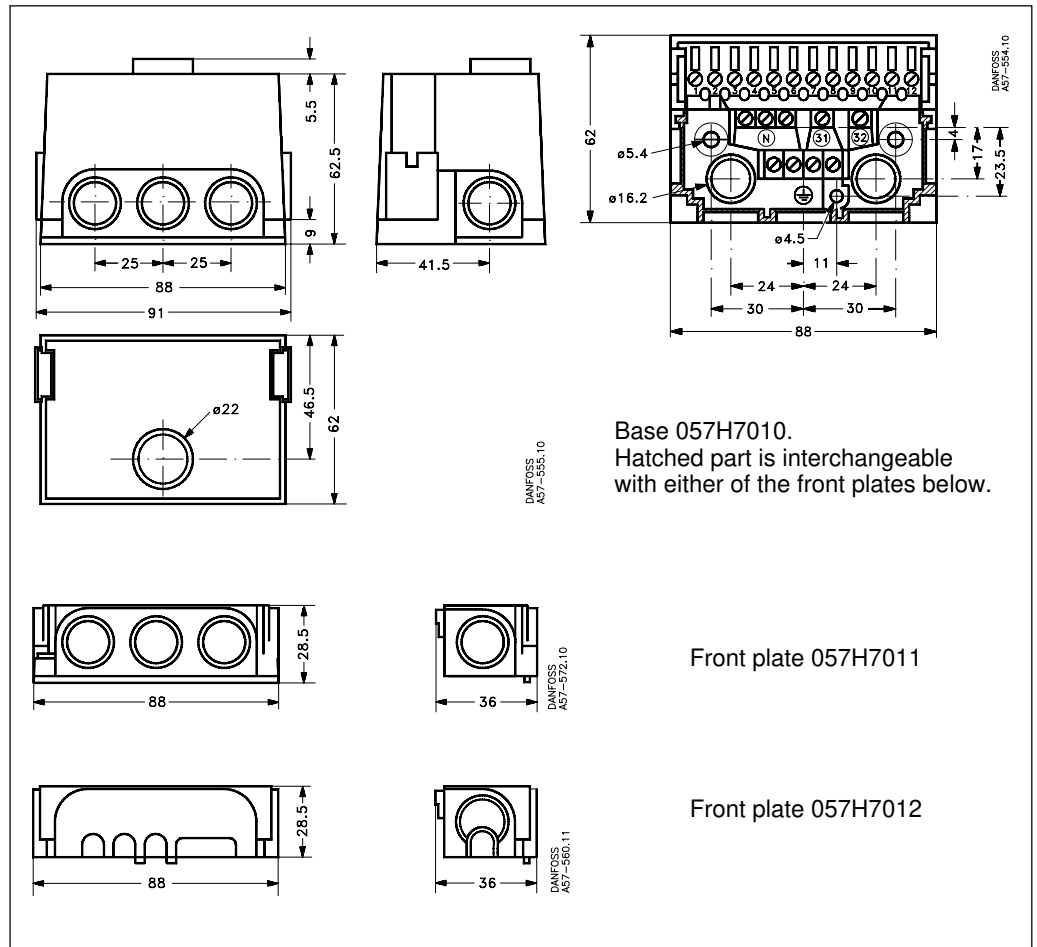

**LD/LDS**

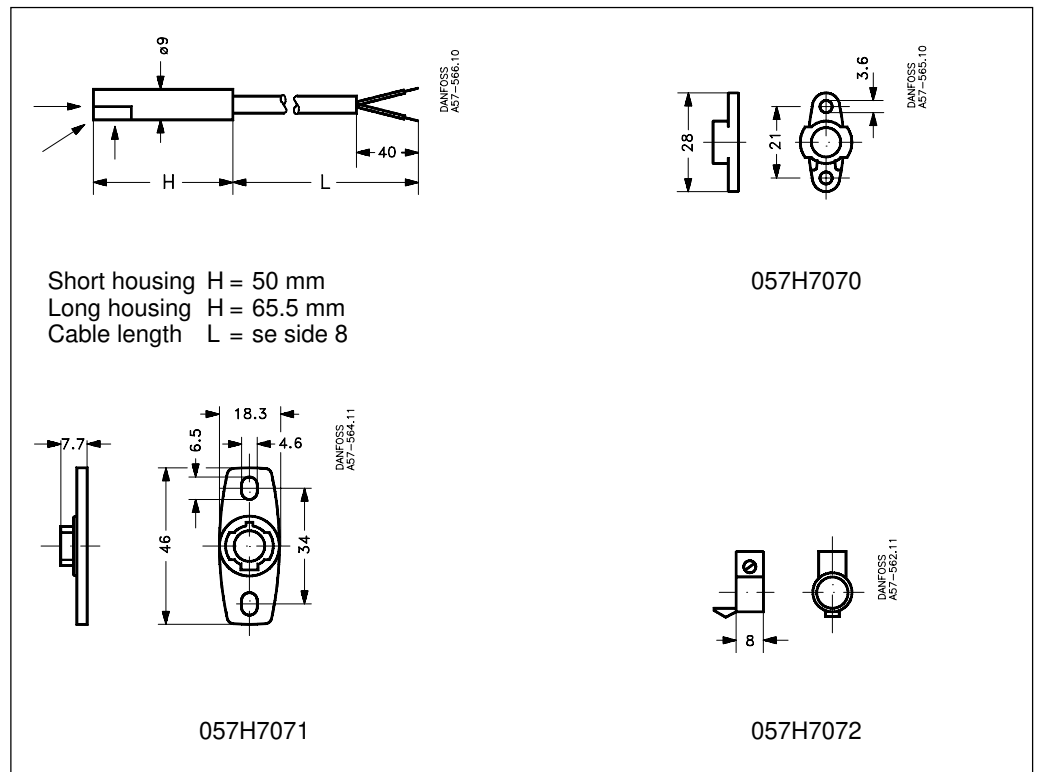

**Adapter**

The new series of controls has 12 connection terminals and replace BHO 11/12 series, and the BHO 1, BHO 3, BHO 4 which all have 9 connection terminals.

To make servicing easier, Danfoss supplies an adapter, type BHA 11/12, which can be mounted in the old base. Then, with light finger pressure, the new control can be mounted on the adapter.

The adapter can be used for all controls with the same terminal arrangement as BHO 11/12, 57H1, 57H3, BHO 1, BHO 1 WLE, BHO 3, BHO 4, BHO 4 WLE.

**The adapter cannot be used with BHO 15 and BHO 25.**

To ensure reliable operation, the photo unit should be replaced with the new type LD/LDS when an adapter is used.

**Using an adapter when replacing a control**

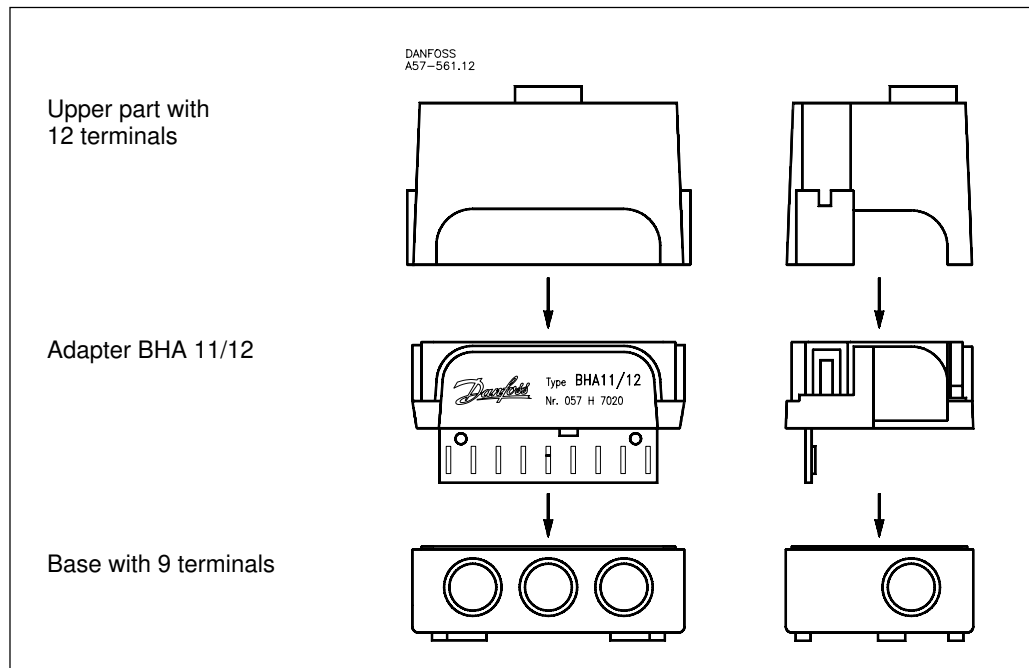

Adapter + BHO 64 assembled has the same height as the BHO 11/12 upper part.



---

Danfoss can accept no responsibility for possible errors in catalogues, brochures and other printed material. Danfoss reserves the right to alter its products without notice. This also applies to products already on order provided that such alterations can be made without subsequential changes being necessary in specifications already agreed. All trademarks in this material are property of the respective companies. Danfoss and the Danfoss logotype are trademarks of Danfoss A/S. All rights reserved.

---

