

Seated valves VRB 3, VRG 3

Description



VRB and VRG valves provide a quality, cost effective solution for most water and chilled applications. These valves may be used with glycol concentrations of up to 50% .

VRG 3 valves: Grey cast iron (GG-25) with external thread.

VRB 3 valves: Red bronze (Rg 5) with internal or external thread.

Main data:

- PN 16
- DN 15 - 50
- Connection: internal or external thread
- Suitable for water or glycolic water
2 (-10*) ... 120 °C
* At temperatures from -10 °C till +2 °C use stem heater.
- Suitable for use with AMV(E) 15, 16, 25, 35, AMV(E) 25 SU/SD and AMV 323, 423, 523 actuators
- Compliance with PED directive 97/23/EC.
- Version VRB 3, for drinking water has DVGW approved (only 3-way mixing valve)

Ordering

3 - way valves (2-way valves ²⁾)

DN	k _{vs} m ³ /h	Code No.		
		Int. thread - VRB 3 ¹⁾	Ext. thread - VRB 3 ¹⁾	Ext. thread - VRG 3
15	0.63	065B1411	065B1311	065B1211
	1.0	065B1412	065B1312	065B1212
	1.6	065B1413	065B1313	065B1213
	2.5	065B1414	065B1314	065B1214
	4.0	065B1415	065B1315	065B1215
20	6.3	065B1420	065B1320	065B1220
25	10	065B1425	065B1325	065B1225
32	16	065B1432	065B1332	065B1232
40	25	065B1440	065B1340	065B1240
50	40	065B1450	065B1350	065B1250

Accessories ²⁾

Closing plug with gasket for VRB int. thread (GG 25)

Type	Code No.
Closing plug with gasket DN 15	065Z7025
Closing plug with gasket DN 20	065Z7026
Closing plug with gasket DN 25	065Z7027
Closing plug with gasket DN 32	065Z7028
Closing plug with gasket DN 40	065Z7029
Closing plug with gasket DN 50	065Z7030

Closing nut with gasket for VRB / VRG ext. thread (GG 25)

Type	Code No.
Closing nut with gasket DN 15	065Z7001
Closing nut with gasket DN 20	065Z7002
Closing nut with gasket DN 25	065Z7003
Closing nut with gasket DN 32	065Z7004
Closing nut with gasket DN 40	065Z7005
Closing nut with gasket DN 50	065Z7006

¹⁾ DVGW approved

²⁾ The 3-way valve can be used as a 2-way valve by using the:
(not for drinking water)
- closing plug (int. thread) or
- closing nut (ext. thread)

Ordering (continuous)
Accessories - stem heater ¹⁾

Type	Code No.
Stem heater 24 V (AMV/AME 15, 16, 25, 35 and valves DN 15 - 50)	065B2171

¹⁾ At temperatures from -10 °C till +2 °C use stem heater.

Spare parts - stuffing box ³⁾

Type	Code No.
For valves VRB / VRG DN 15 - 50	065B0008

³⁾ - Stuffing box
- Gland ring
- Instructions

**Accessories - 3 tailpieces internal thread for
VRB / VRG ext. thread (GGG 50) ²⁾**

R _p	DN	Code No.
½	15	065B4107
¾	20	065B4108
1	25	065B4109
1 ¼	32	065B4110
1 ½	40	065B4111
2	50	065B4112

²⁾ not for drinking water

Technical data

Nominal pressure	PN 16
Control characteristic	LOG: port A-AB; LIN: port B-AB
Medium	Circulation water / Glycolic water up to 50 %
Medium temperature	2 (-10) ... 120 °C (from -10 °C ... +2 °C with stem heater)
Control range	k _{vs} 0.63: min. 30:1 / k _{vs} 1.0 - 4.0: min. 50:1 / DN 20 - DN 50: min. 100:1
Connection	VRB 3: internal thread EN 10226-1 VRB 3, VRG 3: external thread DIN ISO 228/1

Material

Type	VRG 3	VRB 3
Body	Grey cast iron EN-GJL-250 (GG-25)	Red bronze 2.1096.1 (RG5)
Spindle	Stainless steel	Stainless steel
Cone	Brass	Brass
Gasket	EPDM	EPDM

Leakage loss at closed valve

2 - way valves	(A-AB)	Max. 0.05% of k _{vs}
3 - way valves	(A-AB)	Max. 0.05% of k _{vs}
	(B-AB)	Max. 1% of k _{vs}

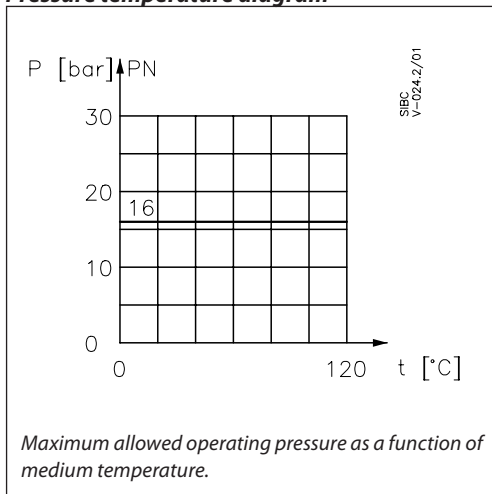
Pressure temperature diagram

Max. closing pressure and recommended Δp (VRB / VRG)

Valve				Actuator type				
DN	Int. thread ISO 7/1	Ext. thread ISO 228/1	Stroke mm	AMV(E) 15 500 N	AMV(E) 16 300 N	AMV(E) 25 1000 N AMV(E) 25 SU/SD 450 N	AMV(E) 35, AMV 323 600 N	AMV 423, 523 1200 N
max. closing pressure (bar)								
15	R _p ½	G 1	10	16	9	16 [16]	16	16
20	R _p ¾	G 1¼	15	11	4	16 [10]	13	16
25	R _p 1	G 1½	15	6	2	16 [5]	8	16
32	R _p 1¼	G 2	15	3	1	9.0 [2.5]	5	12
40	R _p 1½	G 2¼	15	2	-	6.0 [2]	3	8
50	R _p 2	G 2¾	15	1	-	3.0 [0.5]	2	5

NOTE:

Max. Δp is the physical limit of differential pressure the valve will close against.

The recommended Δp is based on the generation of noise, plug erosion etc.

Max. recommended Δp is 4 bar. If max. closing pressure is smaller than 4 bar than the recommended Δp is the same as closing Δp .

Values in parantheses [] are based on the force of the actuator AMV(E) 25 SU/SD only.

Valve characteristics

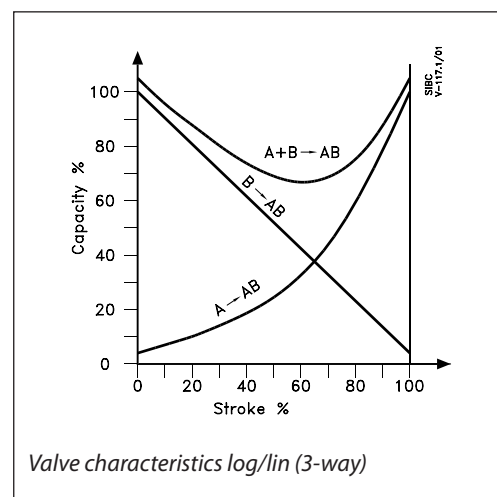
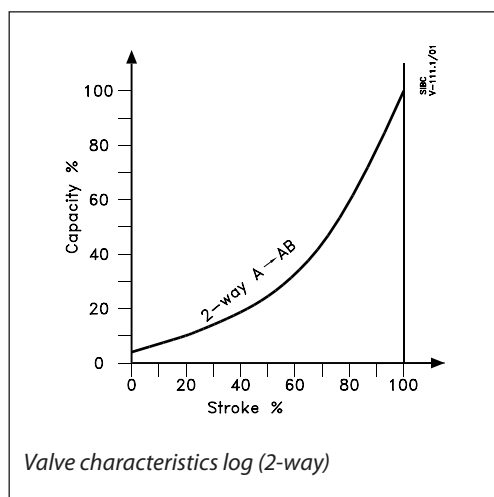

Installation

Hydraulic connections

Mount according to flow direction as indicated on valve body, AB is always the outlet port; inlets are A (two port) or A and B (three port).

Valve mounting

Install the motorized valves with the actuator in a vertical or horizontal position but not upside down.

The valve must not be installed in an explosive atmosphere or at an ambient temperature higher than 50 °C or lower than 2 °C. It must not be subject to steam jets, water jets or dripping liquid.

Note that the actuator may be rotated up to 360° with respect to the valve body by loosening the retaining fixture. After this operation retighten.

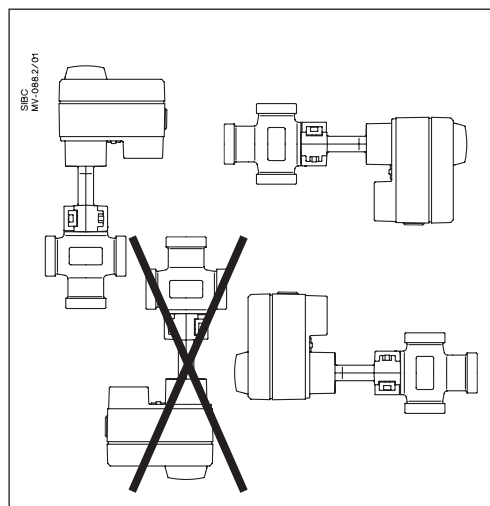

Application principles for 3-way mixing valves (Fig.1 and 2)

Note the valve must only be used as a mixing valve, and is not suitable for diverting (with one inlet and two outlet ports). Where this function is required, the valve should be mounted in the return line, as Fig. 2.

Note that if the pump is installed before the A port of the below valve arrangement, then excessive valve hammering will occur thus causing an overload of the actuator.

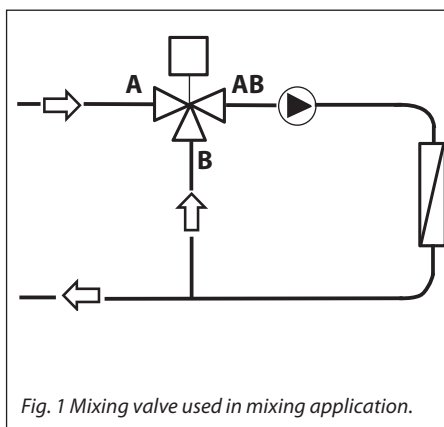

Fig. 1 Mixing valve used in mixing application.

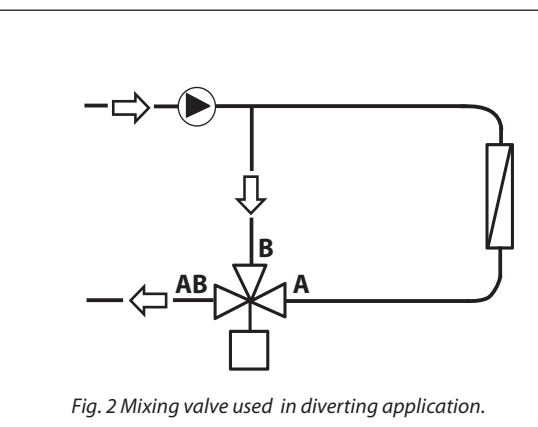
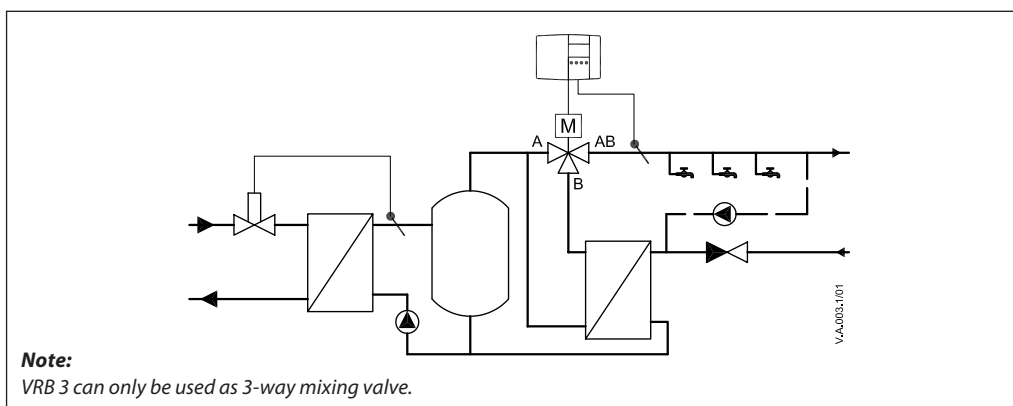

Fig. 2 Mixing valve used in diverting application.

Application principle (for VRB 3 only)



Disposal

The valve must be dismantled and the elements sorted into various material groups before disposal.

Control valve sizing diagram for fluids

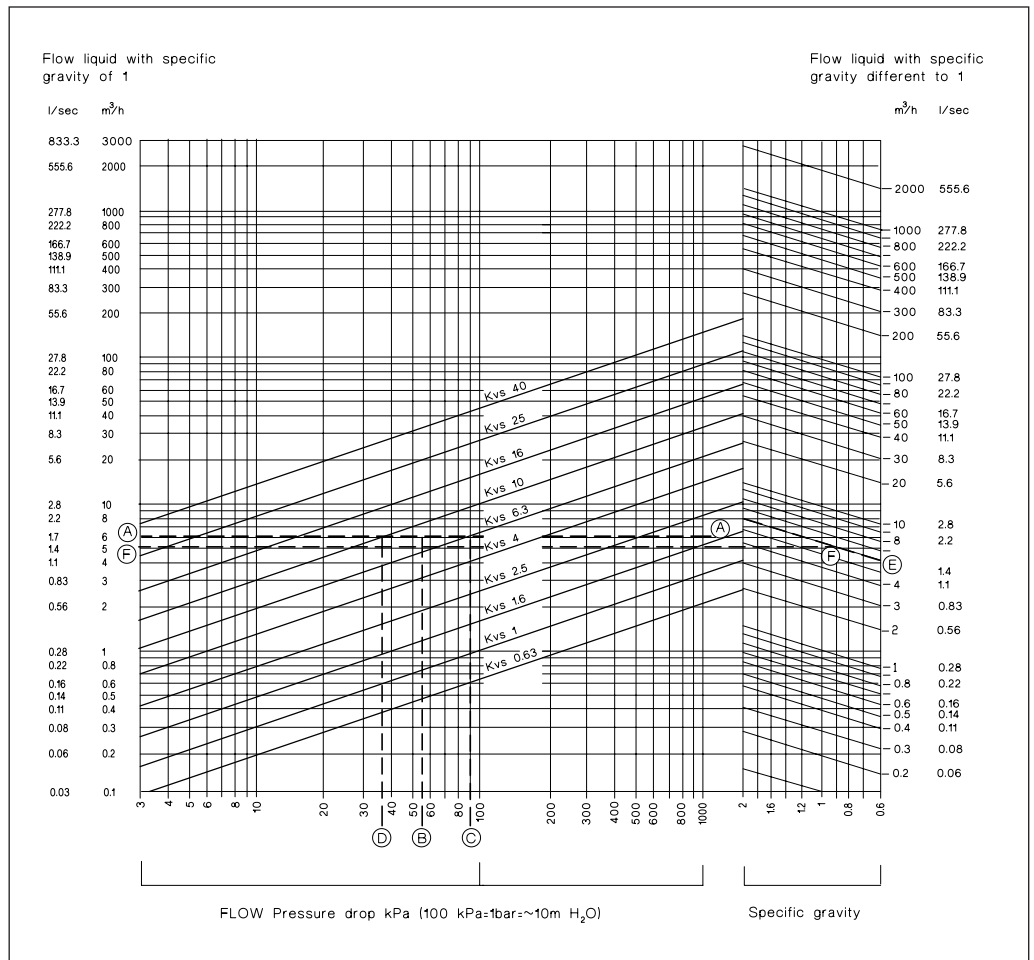

Control valve sizing diagram for fluids (continued)
Examples
1 For fluids with specific gravity of 1 (e.g. water)
Design data:

 Flow rate: 6 m³/h

System pressure drop: 55 kPa

Locate the horizontal line representing a flow rate of 6 m³/h (line A-A). The valve authority is given by the equation:

$$\text{Valve authority, } a = \frac{\Delta p_1}{\Delta p_1 - \Delta p_2}$$

Where:
 Δp_1 = pressure drop across the fully open valve

 Δp_2 = pressure drop across the rest of the circuit with a full open valve

The ideal valve would give a pressure drop equal to the system pressure drop (i.e. an authority of 0.5):

$$\text{If } \Delta p_1 = \Delta p_2,$$

$$a = \Delta p^{1/2} * \Delta p_1 = 0.5$$

In this example an authority of 0.5 would be given by a valve having a pressure drop of 55 kPa at that flow rate (point B). The intersection of line A-A with a vertical line drawn from B lies between two diagonal lines; this means that no ideally-sized valve is available. The intersection of line A-A with the diagonal lines gives the pressure drops stated by real, rather than ideal, valves. In this case, a valve with kvs 6.3 would give a pressure drop of 90.7 kPa (point C):

$$\text{hence valve authority} = \frac{90.7}{90.7 + 55} = 0.62$$

The second largest valve, with kvs 10, would give a pressure drop of 36 kPa (point D):

$$\text{hence valve authority} = \frac{36}{36 + 55} = 0.395$$

Generally, for a 3 port application, the smaller valve would be selected (resulting in a valve authority higher than 0.5 and therefore improved controllability). However, this will increase the total pressure and should be checked by the system designer for compatibility with available pump heads, etc. The ideal authority is 0.5 with a preferred range of between 0.4 and 0.7.

2 For fluids with specific gravity different from 1
Design data:

 Flow rate: 6 m³/h of fluid, S.G. 0.9

System pressure drop: 10 kPa

For this example, the left hand axis of the diagram must be ignored. Starting from the RH axis, the flow rate of 6 m³/h is located (point E). The intersection of the diagonal line from point E with a vertical line from

S.G. = 0.9 gives the starting point for the effective flow rate line F-F. The process then continues as for Example 1, so 10 kPa intersects F-F nearest to the k_{vs} 16 diagonal. The intersection of F-F with k_{vs} 16 gives a valve pressure drop of 12.7 kPa (point G).

Dimensions

VRB / VRG + AMV(E) 15, 16, 25, 35

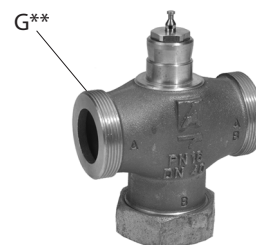
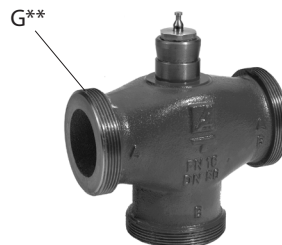
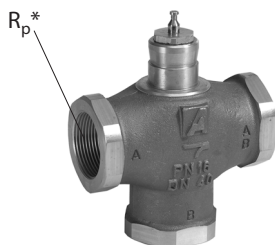
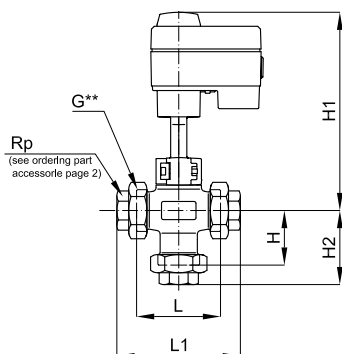

VRG 3 / VRB 3
(as 2-way valves)

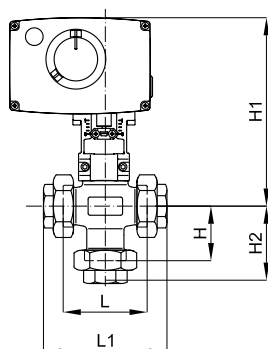

Type	DN	Connection	L mm	L ₁ mm	H mm	H ₁ mm	H ₂ mm	H ₃ mm	Weight kg
VRB	15	*int. Rp 1/2	80	-	47	214	-	202	0.7
VRB	20	*int. Rp 3/4	80	-	55	215	-	203	1.1
VRB	25	*int. Rp 1	95	-	60	215	-	203	1.4
VRB	32	*int. Rp 1 1/4	112	-	66	222	-	210	2.0
VRB	40	*int. Rp 1 1/2	132	-	75	226	-	214	2.9
VRB	50	*int. Rp 2	160	-	85	232	-	220	4.3
VRB / VRG	15	**ext. G 1	80	128	40	214	64	202	1.0
VRB / VRG	20	**ext. G 1 1/4	80	128	55	215	79	203	1.2
VRB / VRG	25	**ext. G 1 1/2	95	151	60	215	88	203	1.4
VRB / VRG	32	**ext. G 2	112	178	66	222	99	210	1.8
VRB / VRG	40	**ext. G 2 1/4	132	201	75	226	110	214	2.5
VRB / VRG	50	**ext. G 2 3/4	160	234	85	232	122	220	3.7

* R_p ... internal thread EN 10226-1
** G ... external thread DIN ISO 228/1

VRB / VRG + AMV 323, 423, 523

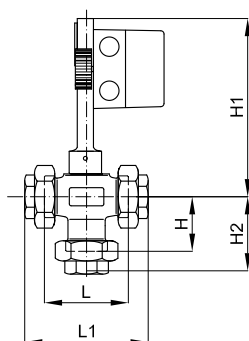

Type	DN	Connection	L mm	L ₁ mm	H mm	H ₁ mm	H ₂ mm	Weight kg
VRB	15	*int. Rp 1/2	80	-	47	266	-	0.7
VRB	20	*int. Rp 3/4	80	-	55	266	-	1.1
VRB	25	*int. Rp 1	95	-	60	266	-	1.4
VRB	32	*int. Rp 1 1/4	112	-	66	272	-	2.0
VRB	40	*int. Rp 1 1/2	132	-	75	276	-	2.9
VRB	50	*int. Rp 2	160	-	85	282	-	4.3
VRB / VRG	15	**ext. G 1	80	128	40	266	64	1.0
VRB / VRG	20	**ext. G 1 1/4	80	128	55	266	79	1.2
VRB / VRG	25	**ext. G 1 1/2	95	151	60	266	88	1.4
VRB / VRG	32	**ext. G 2	112	178	66	272	99	1.8
VRB / VRG	40	**ext. G 2 1/4	132	201	75	276	110	2.5
VRB / VRG	50	**ext. G 2 3/4	160	234	85	282	122	3.7

