

Service guide

Solenoid valve

Type EVR 25 (version 2)

032R9606

032R9606

NC solder

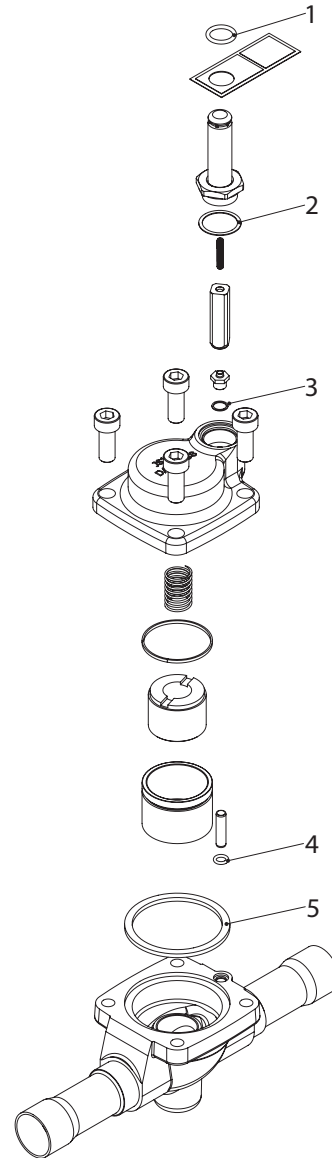
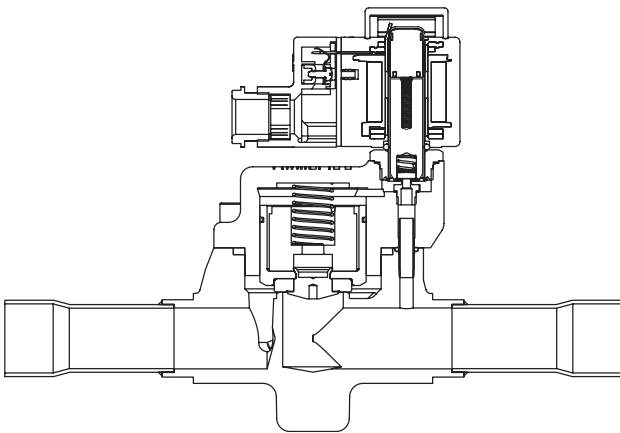
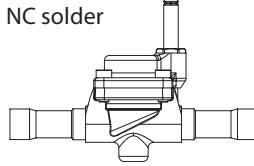

Mounting / dismounting of top part

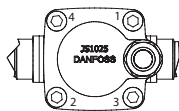
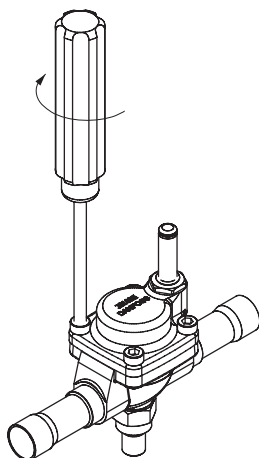

Note!
Always use
cross-tightening

[Nm]	[kpm]	[ft-lbs]
30	3.0	22.5

Pos. no.	Description	Dimension	Material	Piston	Pilot	Inspection kit
1	O-ring	ID 14.30 x H 2.40	EPDM	•		•
2	Gasket	ID 22.5 x OD 26.4 x H 0.35	SS+NBR		•	•
3	Al-Gasket	ID 8.1 x OD 10.1 x H 0.5	Al			•
4	Gasket	ID 6.07 x H 1.78	Chloroprene	•		•
5	Gasket x 2	OD 66.0 x ID 58.0 x H 3.4	Chloroprene	•		•