

Guia de Serviço

Válvula solenoide

Tipos EVR 32 - EVR 40 (Versão 2)

032R9607

032R9607

Solda NF

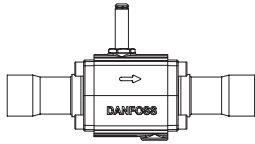

Solda NA

Observação:
design da tubulação

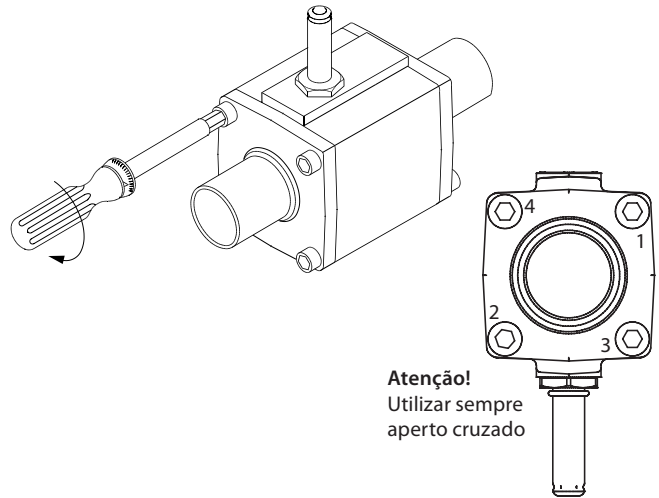
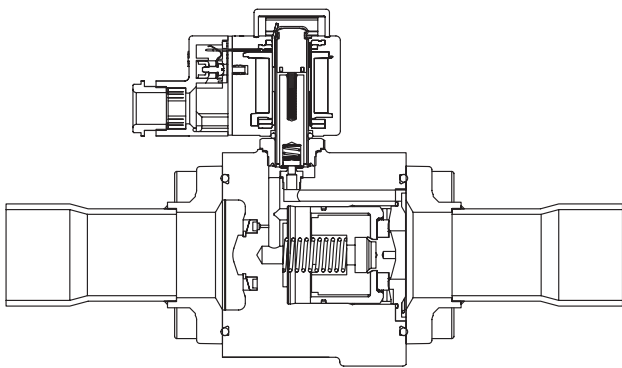
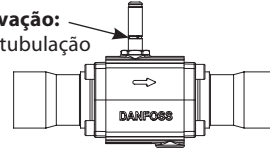

Atenção!
Utilizar sempre
aperto cruzado

[Nm]	[kpm]	[pés-lbs]
30	2,0	15

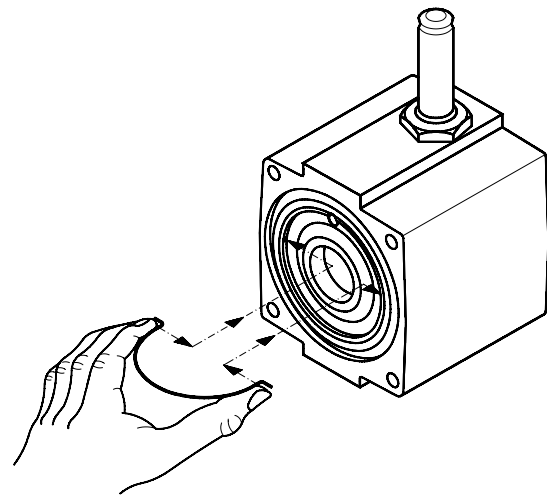
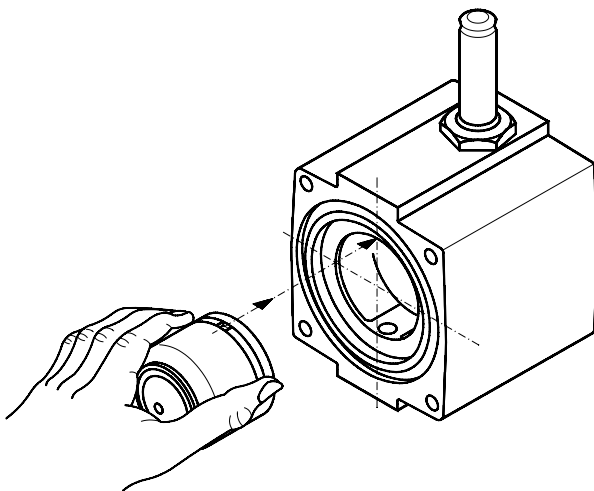

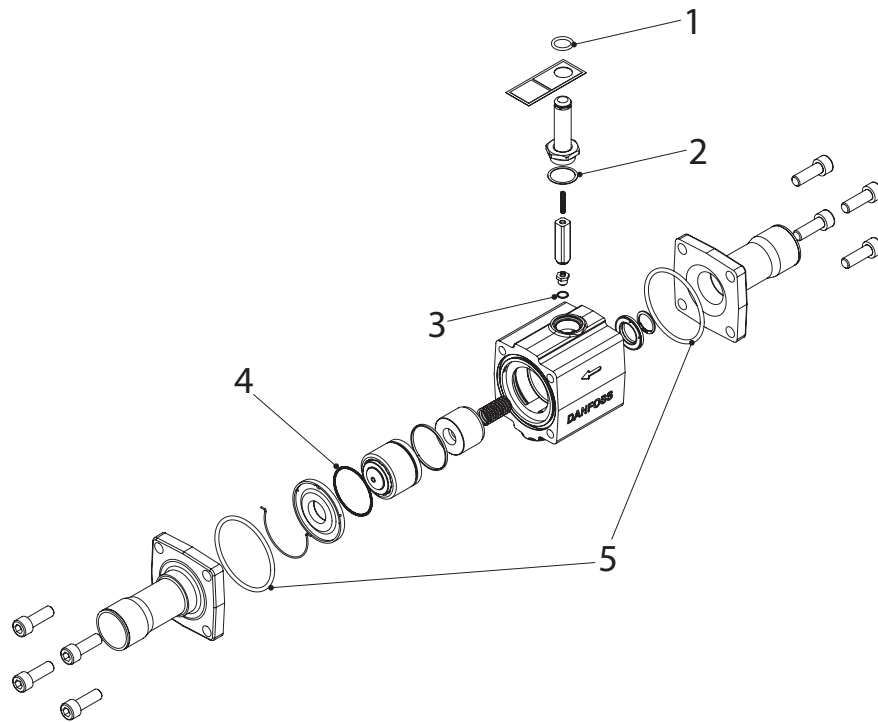

N.º de pos.	Descrição	Dimensão	Material	Pistão	Piloto	kit de inspeção
1	Gaxeta-AL	ID 14.30 x H 2.40	Cloropreno	•		•
2	Gaxeta	ID 22.5 x OD 26.4 x H 0.35	SS+NBR		•	•
3	Anel de vedação	ID 8.1 x OD 10.1 x H 0.5	Al			•
4	Anel de vedação x 2	ID 42.00 x H 1.50	Cloropreno	•		•
5	O-ring x 2	ID 66.27 x H 3.53	Cloropreno	•		•