

Service guide

Non-return valve

VCM 92

Disassembling and Assembling



The Service guide covers the instruction for disassembling and assembling the VCM 92 Non-return valve.

IMPORTANT:

It is essential that the VCM 92 is serviced in conditions of absolute cleanliness.

WARNING:

Do not use silicone when assembling the VCM 92. Do not reuse disassembled O-rings; they might be damaged.

Always use new O-rings.

For a better understanding of the VCM 92, please see the sectional view.

Tools needed:

- 5 mm Allan key
- Torque wrench
- Screwdriver

Disassembling



1. Remove the 24 pcs. M6 screws with a 5 mm Allan key

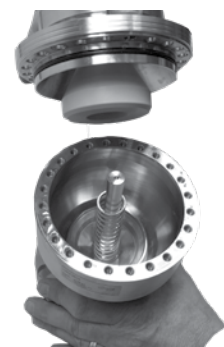

2. Remove the cover

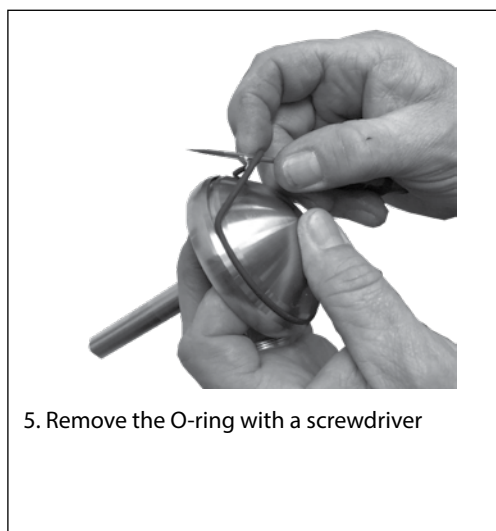
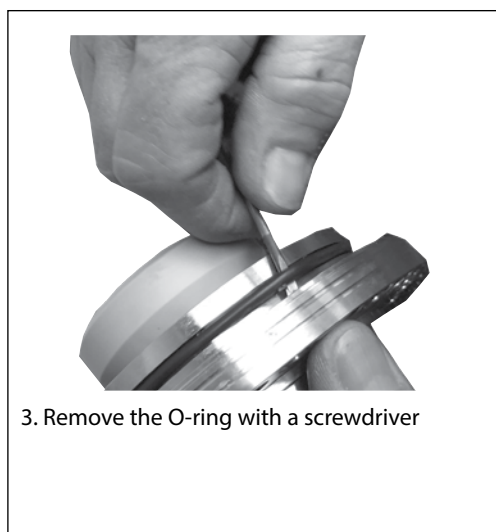

Assembling

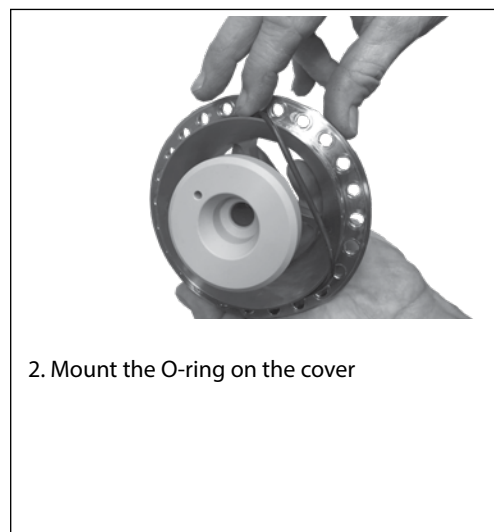
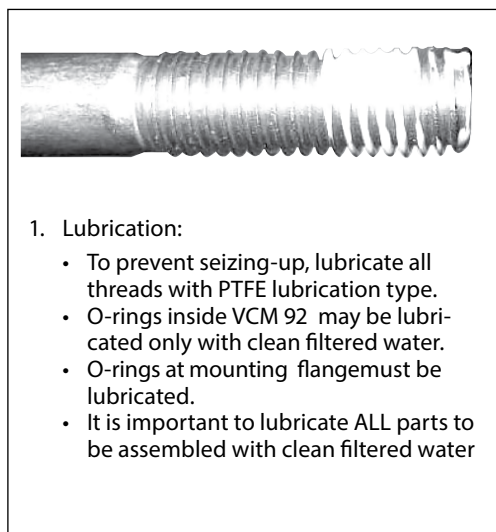

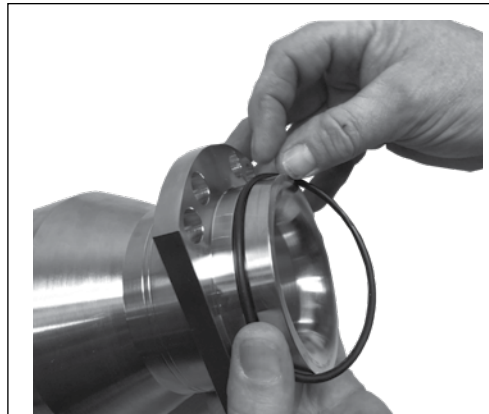

3. Mount O-ring on port flange and lubricate



4. Mount the O-ring on the cone



5. Mount the cone



6. Mount the spring on the cone.



7. Lubricate the O-ring at cover with clean filtered water



8. Mount the cover

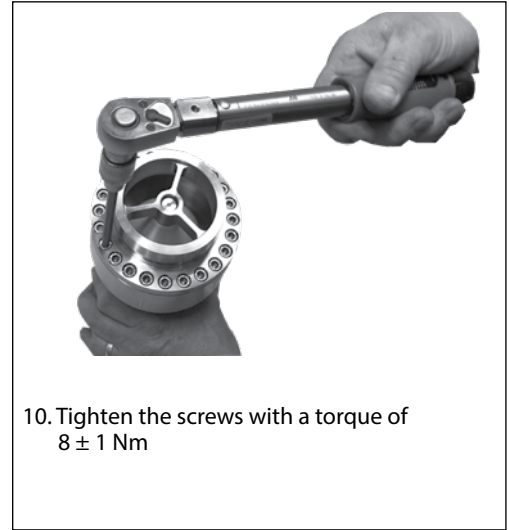
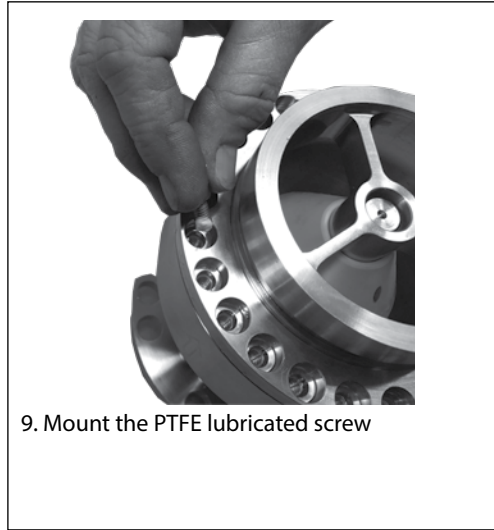

Spare part list and sectional drawing

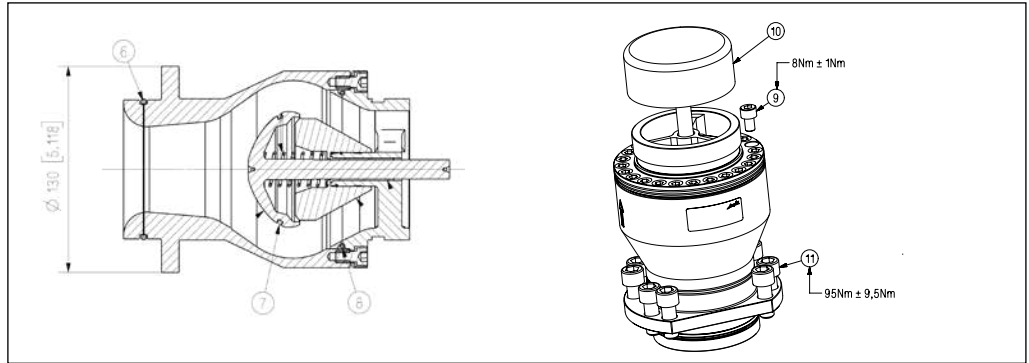

Testing valve function:
Verify free movement of valve cone.

Spare part list

Pos.	Qty.	Designation	Material	Seal set 180H4001	Screw set 180H4002
6	1	O-ring 78.97 x 3.53	NBR	x	
7	1	O-ring 64.00 x 3.00	FPM	x	
8	1	O-ring 93.00 x 3.00	NBR	x	
9	24	Screw M6 x 12	Stainless steel AISI 316		x
11	8	Screw M12 x 30	Stainless steel AISI 316		x

Service interval

4 years for inspection and exchanging O-rings as needed.

Danfoss A/S
High Pressure Pumps
Nordborgvej 81
DK-6430 Nordborg
Denmark

Danfoss can accept no responsibility for possible errors in catalogues, brochures and other printed material. Danfoss reserves the right to alter its products without notice. This also applies to products already on order provided that such alterations can be made without consequential changes being necessary in specifications already agreed. All trademarks in this material are property of the respective companies. Danfoss and the Danfoss logotype are trademarks of Danfoss A/S. All rights reserved.