

Data Sheet

Solenoid valve
Type **EV210A**

Direct-operated 2/2- way solenoid valves for use in industrial machinery



EV210A covers a wide range of small, direct-operated 2/2-way solenoid valves for use in industrial machinery.



The compact design together with the broad range of coils means that EV210A covers a broad variety of industrial applications.

Features and versions

- For water, steam, oil, compressed air, aggressive liquids and gases
- Screw on coil
- Ambient temperature: Up to 50 °C
- Coil enclosure: Up to IP65
- EV210A NC and NO versions in brass for neutral media
- EV210A NC stainless steel version for neutral and aggressive liquids and gases

1 Portfolio overview

Table 1: Portfolio overview

Features	EV210A NC	EV210A NO	EV210A NC
			
Body material	Brass	Brass	Stainless steel
DN [mm]	1.2-3.5	1.5-3.5	1.2-3.5
Connection	G $\frac{1}{8}$ – G $\frac{1}{4}$	G $\frac{1}{8}$	G $\frac{1}{8}$ – G $\frac{1}{4}$
Sealing material	EPDM, FKM	FKM	FKM
Kv [m³/h]	0.04-0.26	0.06-0.20	0.04-0.26
Differential pressure range [bar]	0-30	0-30	0-30
Temperature range [°C]	-30-120	-10-100	-10-100

2 Functions

2.1 Function NC

Coil voltage disconnected (closed):

When the voltage is disconnected, the armature (2) with the valve plate (3) is pressed down against the valve orifice (4) by the closing spring (1) and the medium's pressure.

The valve will be closed for as long as the voltage to the coil is disconnected.

Coil voltage connected (open):

When voltage is applied to the coil (5), the armature (2) with the valve plate (3) is lifted clear of the valve orifice (4).

The valve is now open for unimpeded flow and will be open for as long as there is voltage to the coil.

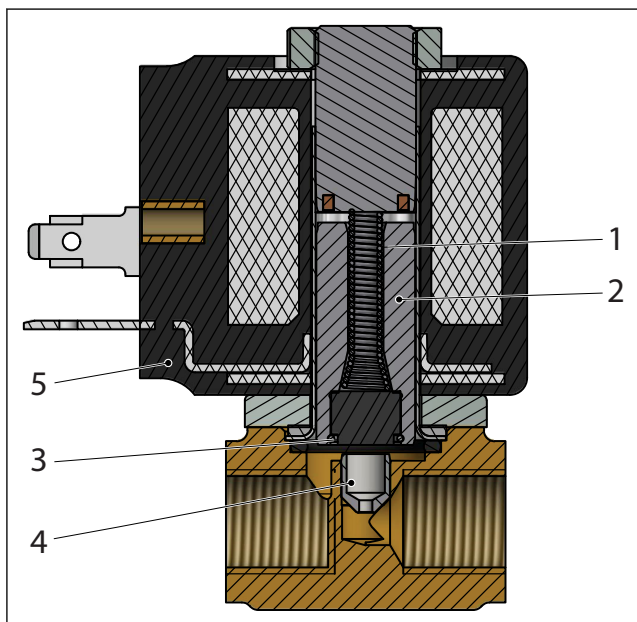

1	Closing spring
2	Armature
3	Valve plate
4	Valve orifice
5	Coil

2.2 Function NO

Coil voltage disconnected (open):

When the voltage to the coil is disconnected, the valve orifice (6) is open, the opening spring (3) pressing the valve plate (7) clear of the orifice (6) via the armature (4) and the pins (5). The valve will be open for as long as the supply voltage is disconnected.

Coil voltage connected (closed):

When voltage is applied to the coil, the armature (4) is drawn up to touch the fixed top (2). The valve plate (7) is pressed against the valve orifice (6) by the closing spring (8). The valve will be closed for as long as there is voltage to the coil.

Solenoid valve, type EV210A

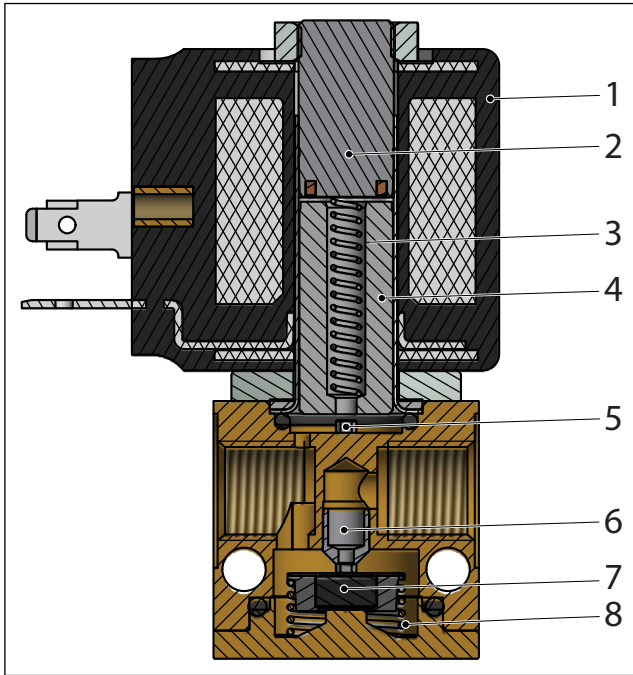

1	Coil
2	Fixed top
3	Opening spring
4	Armature
5	Pins
6	Valve orifice
7	Valve plate
8	Closing spring

3 Applications

It is recommended to use a filter in front of the valve. Recommended filter 50 mesh (297 microns).

Figure 1: Filter

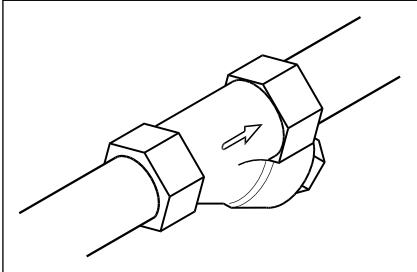

In water applications, exercise the valves at least once every 24 hours, meaning change the state of the valve. The valve exercise will minimize the risk of the valve sticking due to calcium carbonate, zinc or iron oxide build-up.

Figure 2: Exercise: Valve on/off

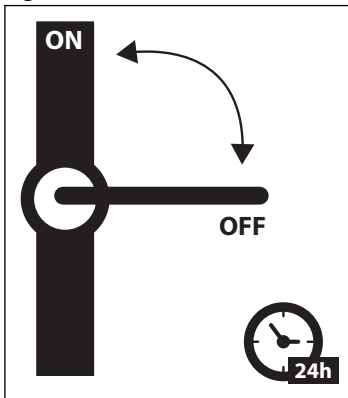

To minimize scaling, and corrosion attack it is recommended that the water passing the valve have the following values:

- Hardness 6 - 18 °dH to avoid scaling (chalk / lime stone build up)
- Conductivity 50 – 800 µS/cm to avoid brass dezincification and corrosion
- Above 25 °C media temperature avoid stagnant water inside the valve to avoid dezincification and corrosion attack

4 Product specification

4.1 Technical data

Table 2: Technical data

Media	FKM	For oil and air
	EPDM	For water
Media temperature [°C]	FKM	-10-100°C
	EPDM	-30-120°C
Ambient temperature [°C]	Max to 50°C	
Kv value [m³/h]	DN1.2	0.04 m³/h
	DN1.5	0.06-0.08 m³/h
	DN2	0.11-0.12 m³/h
	DN2.5	0.15-0.17 m³/h
	DN3	0.18-0.22 m³/h
	DN3.5	0.20-0.26 m³/h
Min. Opening differential pressure [bar]	0 bar	
Max. Opening differential pressure [bar]	Up to 30 bar	
Max. working pressure [bar]	Up to 30 bar (Equal to max. differential pressure)	
Max. test pressure [bar]	50 bar	
Viscosity [cSt]	Max. 20 cSt	

Capacity diagrams

EV210A NC

Example, water at higher pressure: Capacity for EV210A 2.5B at differential pressure of 0.5 bar. Approx. 0.12 m³/h

Figure 3: EV210A NC capacity diagram

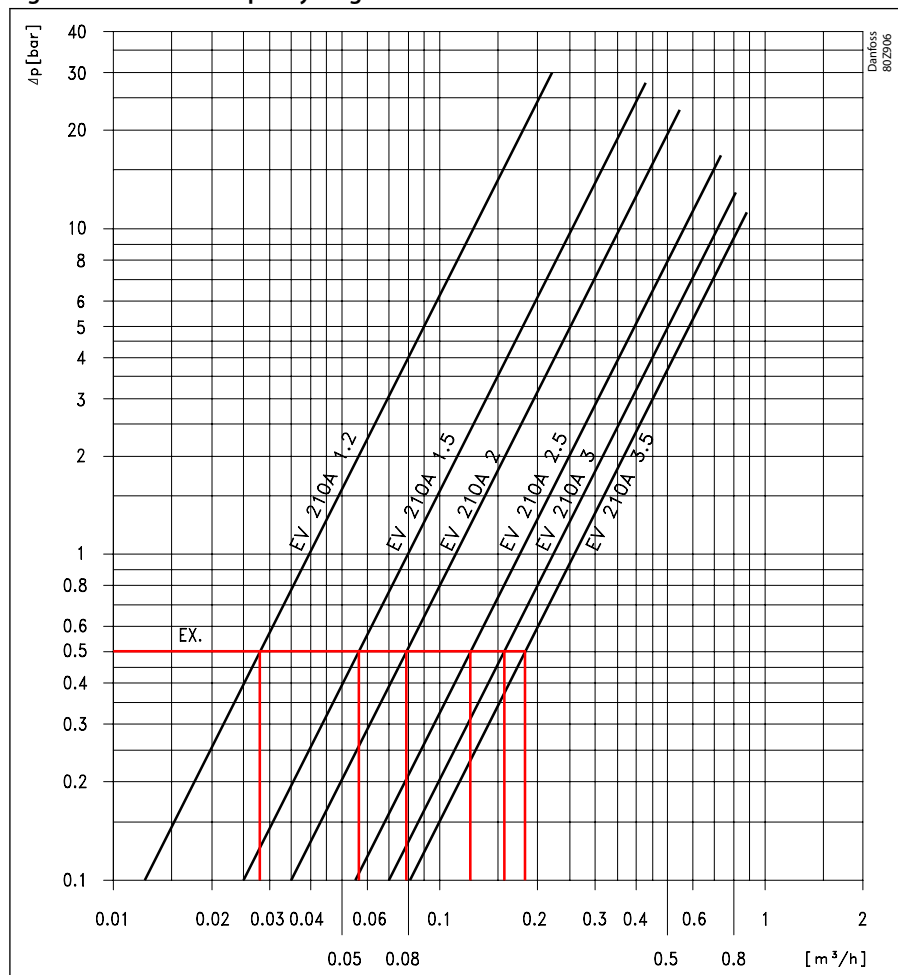

Solenoid valve, type EV210A

Z

EV210A NO

Example, water at higher pressure: Capacity for EV210A 2.5B NO at differential pressure of 0.5 bar. Approx. 0.11s m³/h

Figure 4: EV210A NO capacity diagram

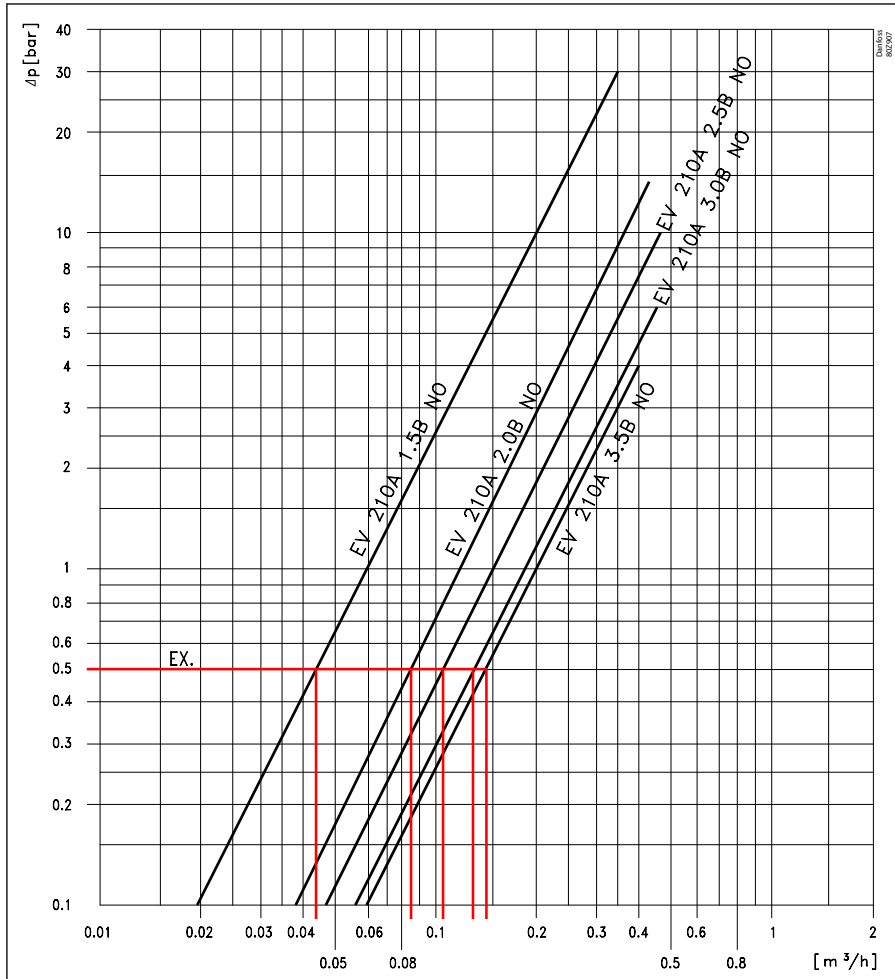

Differential pressure range

Table 3: Differential pressure range, NC and NO

Connection ISO228-1	Orifice size [mm]	Seal material	Media	Differential pressure min. to max. [bar]								
				NC						NO		
				Suitable coil type								
				AB		AC		AM		AK	AM	
AC	DC	AC	DC	AC	DC	DC	AC	DC				
G 1/8	1.2	EPDM	Water	0-30	0-17.5	0-30	0-24	0-30	0-24	0-24		
			FKM	Oil	0-28	0-16	0-30	0-24	0-30	0-24	0-24	
		FKM	Air	0-30	0-19	0-30	0-24	0-30	0-24	0-24		
	1.5	EPDM	Water	0-18 ⁽¹⁾	0-9.5 ⁽¹⁾	0-26 ⁽¹⁾	0-17.5 ⁽¹⁾	0-28 ⁽¹⁾	0-22.5 ⁽¹⁾	0-17.5	0-30	0-16
			FKM	Oil	0-15	0-8	0-24	0-16	0-26	0-19	0-17.5	0-24
		FKM	Air	0-22	0-10.5	0-30	0-18.5	0-30	0-24	0-19	0-30	0-16
	2.0	EPDM	Water	0-11	0-5.5	0-18	0-10.5	0-23	0-18.5	0-9	0-14	0-10
			FKM	Oil	0-9	0-5	0-16	0-9.5	0-22	0-17	0-9	0-11
		FKM	Air	0-14	0-6	0-22	0-11	0-30	0-24	0-9	0-14	0-10

Solenoid valve, type EV210A

Connection ISO228-1	Orifice size	Seal material	Media	Differential pressure min. to max. [bar]											
				NC						NO					
	[mm]			Suitable coil type											
				AB		AC		AM		AK	AM				
	AC	DC	AC	DC	AC	DC	DC	AC	DC						
G $\frac{1}{8}$ - G $\frac{1}{4}$	2.5	EPDM	Water	0-6	0-3	0-11	0-5.5	0-17	0-13	0-5	0-10	0-6			
		FKM	Oil	0-5	0-2.5	0-9	0-5	0-16	0-12	0-5	0-8	0-4.5			
			Air	0-8	0-3	0-12	0-6	0-20	0-14.5	0-5	0-10	0-6			
	3.0	EPDM	Water	0-4	0-1.5	0-7	0-3.5	0-13	0-9	0-3	0-6	0-4			
		FKM	Oil	0-3	0-1.5	0-6	0-3	0-12	0-8	0-3	0-5	0-3			
			Air	0-5	0-2	0-8	0-3.5	0-14	0-9	0-3	0-6	0-4			
G $\frac{1}{8}$ - G $\frac{1}{4}$	3.5	EPDM	Water	0-2.8	0-1.2	0-5	0-2.5	0-11	0-6	0-1.5	0-4	0-3			
		FKM	Oil	0-2	0-0.8	0-4	0-2.5	0-10	0-5.5	0-1.5	0-4	0-2			
			Air	0-3.5	0-1.2	0-5.5	0-2.5	0-6	0-6	0-1.5	0-4	0-3			

⁽¹⁾ Only NC SS

Time to open/close

Table 4: Time to open/close

Type	EV210A 1.2 - 3.5
Time to open and close	7 - 10 ms (depending on pressure, coil and viscosity)

Materials

Table 5: Materials

Components	Materials	Specifications
Valve body	Brass	W. no. 2.0401
	Stainless steel	W.no. 1.4305 / AISI 303
Armature	Stainless steel	W. no. 1.4016 / AISI 430
Armature tube	Stainless steel	W. no. 1.4303 / AISI 305
Armature stop	Stainless steel	W. no. 1.4016 / AISI 430
Spring	Stainless steel	W. no. 1.4310 / AISI 301
Valve orifice	Stainless steel	W. no. 1.4305 / AISI 303
O-ring/ valve plate	EPDM/FKM	

4.2 Dimension and weight

Table 6: Dimension and weight, brass NC

Type	Connection ISO 228/1	Weight gross Valve body with- out coil [kg]	L [mm]	B [mm]		H [mm]	A [mm]
				Coil type AB / AC	Coil type AM / AK		
EV210A	G $\frac{1}{8}$	0.085	26	22	33	54	13
	G $\frac{1}{4}$	0.110	35	22	33	59	17.5

Figure 5: Dimension, brass NC

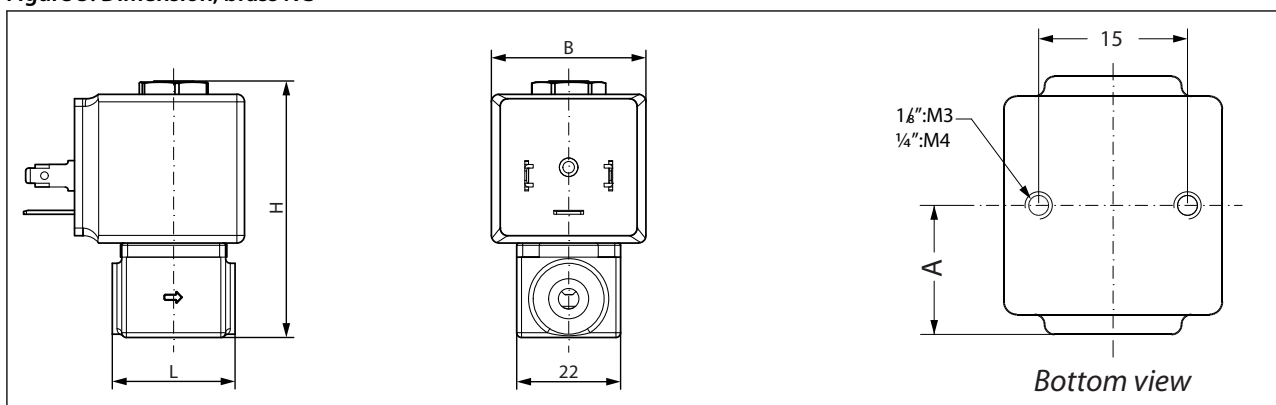

Solenoid valve, type EV210A

Table 7: Dimension and weight, brass NO

Type	Connection ISO 228/1	Weight gross Valve body without coil [kg]	L [mm]	B [mm]	H [mm]
				Coil type AM	
EV210A	G 1/8	0.125	26	33	63

Figure 6: Dimension, brass NO

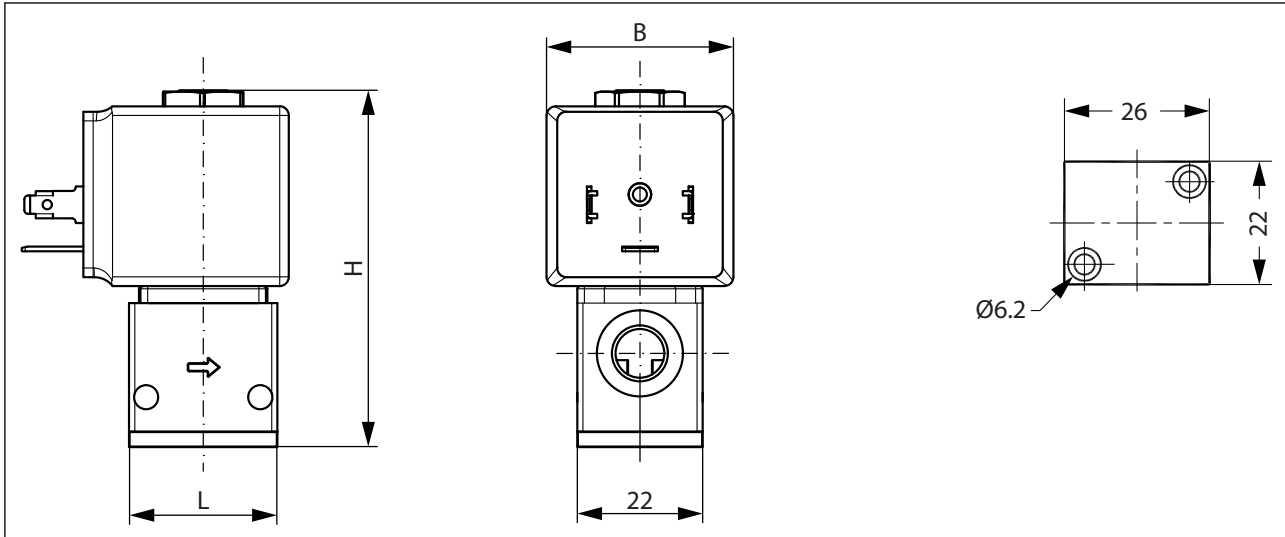
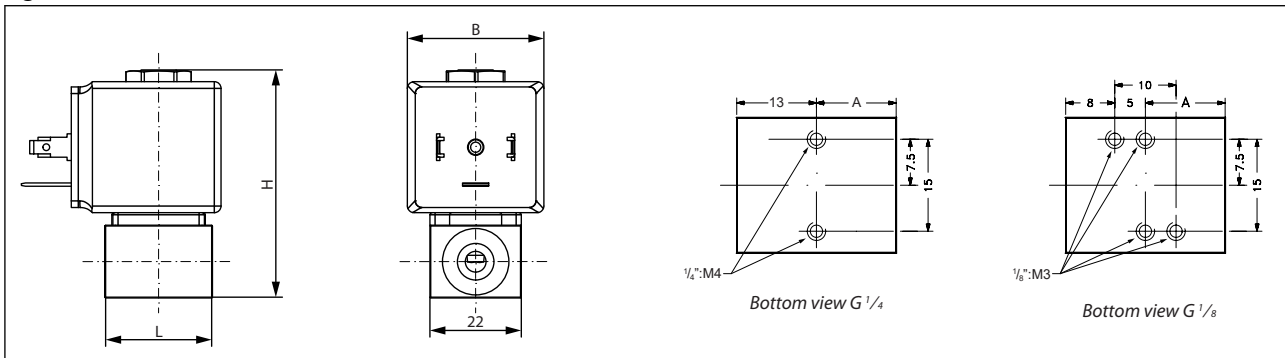

Table 8: Dimension and weight, stainless steel

Type	Connection ISO 228/1	Weight gross Valve body with- out coil [kg]	L [mm]	B [mm]		H [mm]	A [mm]
				Coil type AB / AC	Coil type AM / AK		
EV210A	G 1/8	0.085	26	22	33	54	13
EV210A 6	G 1/4	0.110	35	22	33	59	17.5

Figure 7: Dimension, Stainless steel



4.3 Mounting

Figure 8: EV210A, Mounting angle

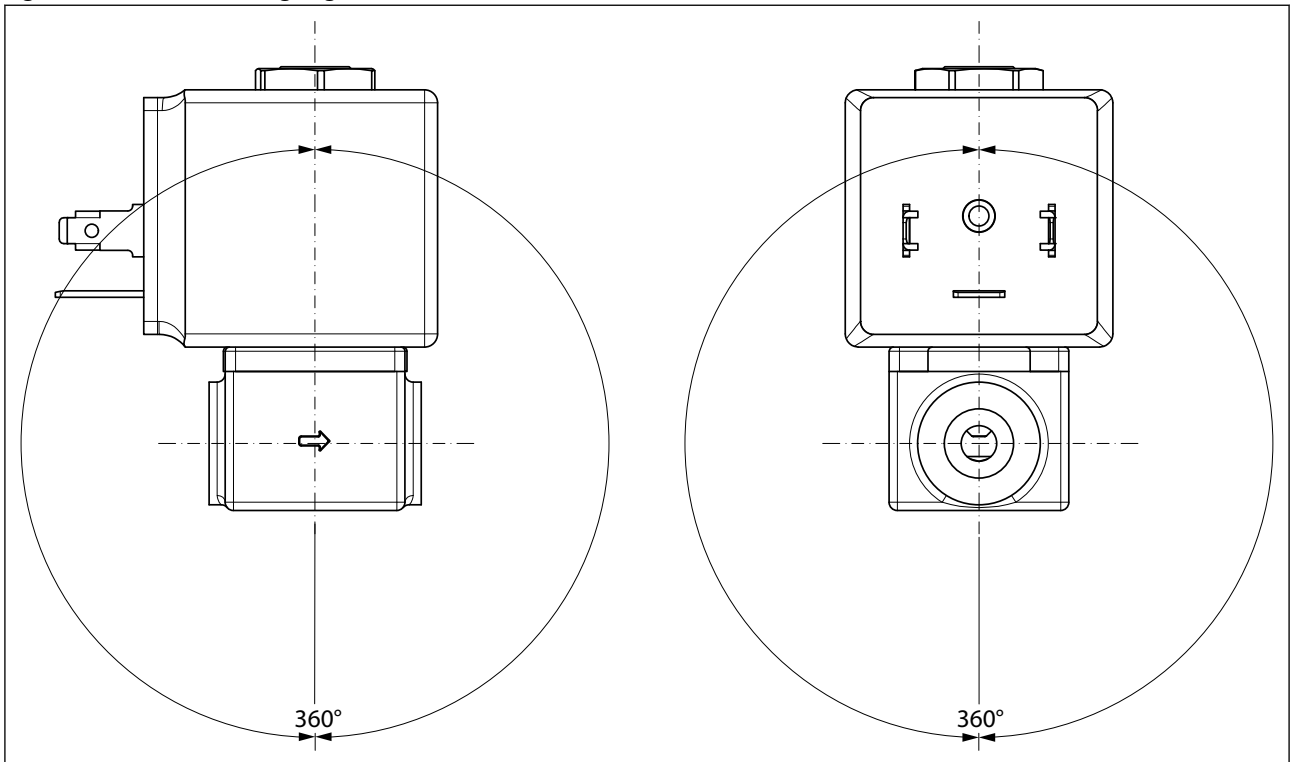

5 Ordering

5.1 Parts program





Table 9: Brass/SS, valve body NC and NO

Connection ISO228/1	Orifice [mm]	Kv value [m ³ /h]	Sealing EPDM/FKM	Function		
				Brass		SS
				NC	NO	NC
G $\frac{1}{8}$	1.2	0.04	EPDM	032H8000		
			FKM	032H8001		032H8025
	1.5	0.08	FKM	032H8003		032H8027
		0.06	FKM		032H8049	
	2.0	0.11	EPDM	032H8004		
			FKM	032H8005		032H8029
		0.12	FKM		032H8051	
	2.5	0.15	FKM		032H8053	
			0.17	EPDM	032H8006	
		0.18	FKM	032H8007		032H8055
	3.0	0.22	EPDM	032H8008		
			FKM	032H8009		032H8033
	3.5	0.20	FKM		032H8057	
	G $\frac{1}{4}$	2.5	0.17	EPDM	032H8014	
FKM				032H8015		032H8039
3.0		0.22	EPDM	032H8016		
			FKM	032H8017		032H8041
3.5		0.26	EPDM	032H8018		
			FKM	032H8019		032H8043

5.2 Accessories

Coils

Table 10: Below coils can be used with EV210A

Coil	Type	Power consumption	Enclosure	Features
	AB	4.5 W AC 5 W DC	IP00 with spade connector, IP65 with cable plug	In accordance with VDE 0580
	AC	7.0 W AC 10 W DC	IP00 with spade connector, IP65 with cable plug	In accordance with VDE 0580
	AM	7.5 W AC 9.5 W DC	IP00 with spade connector, IP65 with cable plug	In accordance with VDE 0580
	AK	3.0 W DC	IP00 with spade connector, IP65 with cable plug	In accordance with VDE 0580

Solenoid valve, type EV210A

For further information and for ordering, see separate data sheet for coils.

Cable plug

Figure 9: Cable plug



Table 11: Cable plug

Cable plug size	Description	Code no
DIN 18	Cable plug IP65	042N1278

Figure 10: Cable plug



Application	Code number
GM 209 (Black) cable plug according to DIN 46650-B PG9	042N0139

Universal electronic multi-timer, Type ET 20M

Figure 11: ET 20M



Type	Voltage [V]	Suitable for coil types	Code number
BA024A	24 – 240	AL, AM, AS, AZ, BA, BD, BB	042N0185

5.3 Spare parts kit, EV210A NC

Table 12: Spare parts kit

Type	Sealing	
	FKM	EPDM
EV210A 1.2-3.5	042U0068	042U0067
	<ul style="list-style-type: none"> 1. Nut Steel 2. Spring washer 3. 2 x screws 4. Flange 5. Washer 6. Armature tube assembly 7. Armature assembly 8. O-ring 	

6 Online support

Danfoss offers a wide range of support along with our products, including digital product information, software, mobile apps, and expert guidance. See the possibilities below.

The Danfoss Product Store



The Danfoss Product Store is your one-stop shop for everything product related—no matter where you are in the world or what area of the cooling industry you work in. Get quick access to essential information like product specs, code numbers, technical documentation, certifications, accessories, and more.

Start browsing at store.danfoss.com.

Find technical documentation



Find the technical documentation you need to get your project up and running. Get direct access to our official collection of data sheets, certificates and declarations, manuals and guides, 3D models and drawings, case stories, brochures, and much more.

Start searching now at www.danfoss.com/en/service-and-support/documentation.

Danfoss Learning



Danfoss Learning is a free online learning platform. It features courses and materials specifically designed to help engineers, installers, service technicians, and wholesalers better understand the products, applications, industry topics, and trends that will help you do your job better.

Create your Danfoss Learning account for free at www.danfoss.com/en/service-and-support/learning.

Get local information and support



Local Danfoss websites are the main sources for help and information about our company and products. Find product availability, get the latest regional news, or connect with a nearby expert—all in your own language.

Find your local Danfoss website here: www.danfoss.com/en/choose-region.

Spare Parts



Get access to the Danfoss spare parts and service kit catalog right from your smartphone. The app contains a wide range of components for air conditioning and refrigeration applications, such as valves, strainers, pressure switches, and sensors.

Download the Spare Parts app for free at www.danfoss.com/en/service-and-support/downloads.

Any information, including, but not limited to information on selection of product, its application or use, product design, weight, dimensions, capacity or any other technical data in product manuals, catalogues descriptions, advertisements, etc. and whether made available in writing, orally, electronically, online or via download, shall be considered informative, and is only binding if and to the extent, explicit reference is made in a quotation or order confirmation. Danfoss cannot accept any responsibility for possible errors in catalogues, brochures, videos and other material. Danfoss reserves the right to alter its products without notice. This also applies to products ordered but not delivered provided that such alterations can be made without changes to form, fit or function of the product. All trademarks in this material are property of Danfoss A/S or Danfoss group companies. Danfoss and the Danfoss logo are trademarks of Danfoss A/S. All rights reserved.