

# Installation Guide

## Thermostatic Expansion Valves

### TD1 / TDE1

068R9808

**Refrigerants:**

See product label  
For all approved list of refrigerants, visit  
<http://store.danfoss.com/>



**Max. working pressure:**

PS(MWP)=34 bar (500 psig)

**Max. test pressure:**

37.5 bar (540 psig)

068R9808

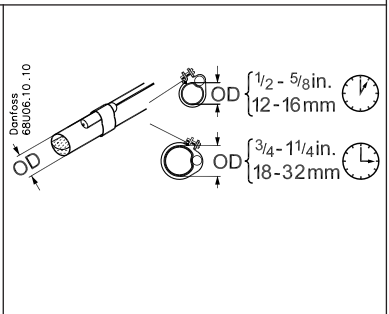
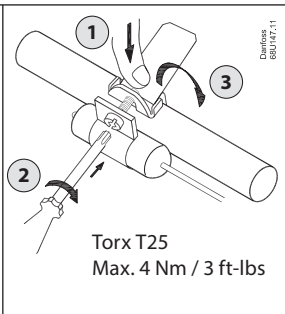
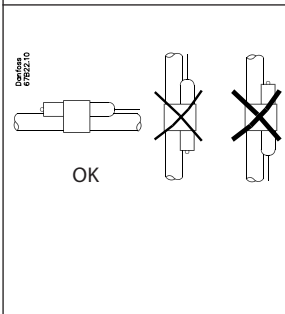
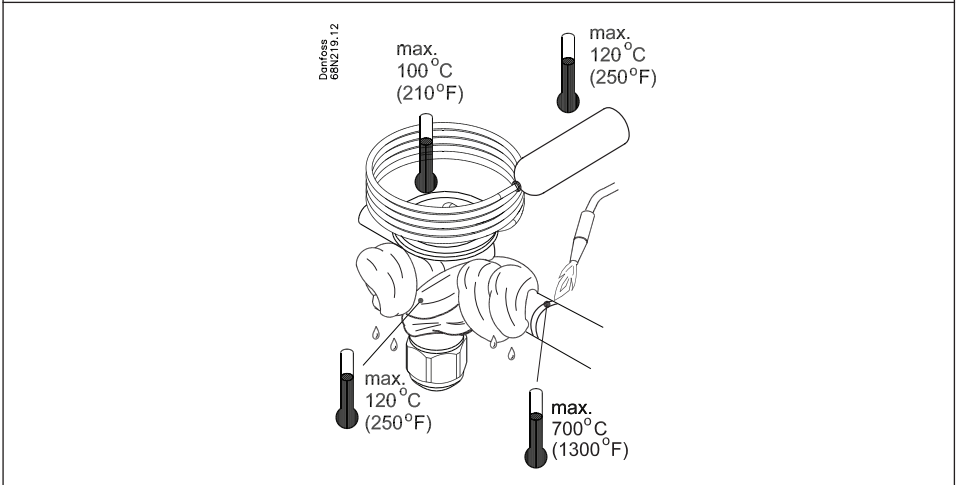
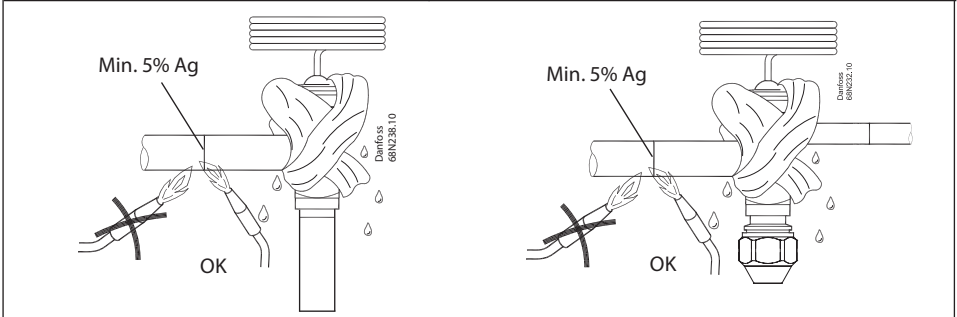

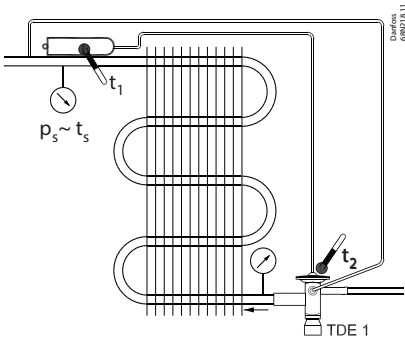

TD1<sub>MOP</sub>:  $t_2 > t_1$   
 SH (°C/°F) =  $t_1 - t_s$

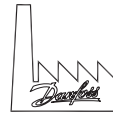
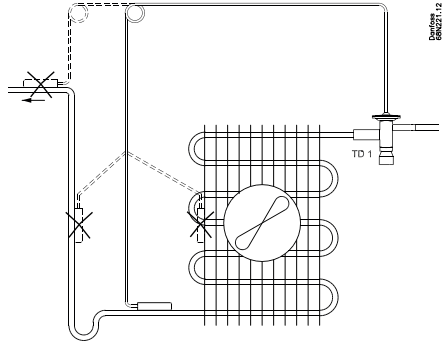

Factory setting  
 Static superheat  
 (SSH):  
 2K - 8K  
 (3.6 °F - 14.4 °F)

Danfoss  
 68N8146.10

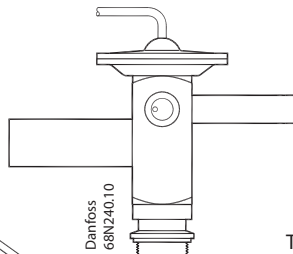
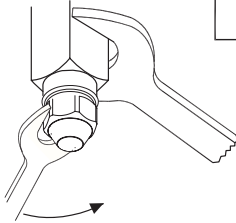

Danfoss  
 68N240.10

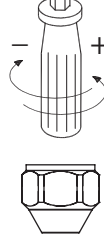

Danfoss  
 68N8146.10

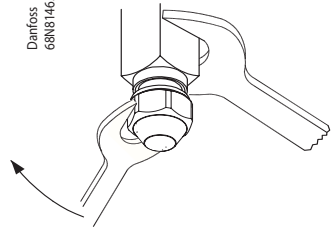

Torque = 10 Nm (7 ft-lbs)

Refrigerants	Setting change
	1 ×
R290	1.5-2.5 K (2.7 - 4.5 °F)*
R134a	
R1234yf	3-4 K (5.4 - 7.2 °F)*
R404A	
R452A	
R454C	2-3 K (3.6 - 5.4 °F)*
R455A	
R22/R407C	

\*Straight way adjustable version only

\*) at 5 °C evaporating temperature