

ENGINEERING
TOMORROW



Service Manual

H1P 045/053/060/068

Axial Piston Single Pumps



Revision history*Table of revisions*

Date	Changed	Rev
December 2021	Added HDC control	0501
April 2021	Corrected mounting screw information	0406
June 2020	Changed document number from 'AX00000104' to 'AX152886481964' and added caution note to start-up procedures	0405
November 2018	Major layout update.	0401
April 2018	add EDC with angle sensor	0303
March 2010	Fix Osaka address	AC
Nov. 2008 - Sep 2014	Various changes.	AB-CB
Jun 2007	First edition	AA

Contents

Introduction

Hydrostatics Servicing Overview..... 5
 General Servicing Instructions..... 5
 Safety Precautions..... 6
 General description of H1 family hydrostatic pumps..... 7
 Design..... 8
 H1 Single Pumps Closed Circuit Pictorial Diagram..... 9
 H1 system schematic..... 10

Operation

Pressure Limiter Valves..... 11
 Pressure Limiter Sectional View..... 11
 High Pressure Relief Valve (HPRV) and Charge Check Valve..... 12
 HPRV/Charge Check Valve Sectional View..... 12
 Charge Pressure Relief Valve (CPRV)..... 13
 Bypass function..... 14
 System Schematic for Single Pump..... 14
 Electrical Displacement Control (EDC)..... 15
 EDC Operation..... 16
 Hydraulic Displacement Control (HDC)..... 17
 HDC principle..... 17
 HDC operation..... 17
 Manual Override (MOR)..... 19
 Manual Displacement Control (MDC) 20
 MDC operation..... 20
 MDC Torque..... 21
 Neutral start switch (NSS)..... 21
 Case Gauge Port M14..... 22

Operating Parameters

Input Speed..... 23
 System Pressure..... 23
 Servo Pressure..... 24
 Charge Pressure..... 24
 Charge Pump Inlet Pressure..... 24
 Case Pressure..... 25
 External Shaft Seal Pressure..... 25
 Temperature..... 25
 Viscosity..... 25

Technical Specifications

H1 Pumps General Specification..... 26
 H1 Pumps Physical Properties 26
 Fluid Specification..... 27

Fluid and Filter Maintenance Recommendations

Filtration System..... 29

Pressure Measurements

Port Locations and Gauge Installation..... 30
 H1P Ports Information..... 30

Initial Startup Procedures

Unintended machine movement..... 31
 Start-Up Procedure..... 31

Troubleshooting

High Inlet Vacuum..... 33
 Unintended machine movement..... 33
 Fluid Under Pressure..... 33
 Electrical Troubleshooting..... 33
 Neutral Difficult or Impossible to Find..... 34

Contents

Transmission Operates Normally in One Direction Only.....	34
System Operating Hot.....	34
System Will Not Operate in Either Direction.....	35
System Noise or Vibration.....	35
Sluggish System Response.....	35

Adjustments

Standard Procedures.....	37
Charge Pressure Relief Valve Adjustments.....	38
Pressure Limiter Adjustment.....	39
Engaging the Bypass Function.....	40
Displacement Limiter Adjustment for Single Pumps.....	42
Control Neutral Adjustment.....	43
Mechanical Neutral Adjustment.....	45
Pump Setup.....	46
Servo Adjustment.....	47

Minor Repair

Standard Procedures at Removing Pump.....	48
EDC/HDC Control Repair.....	49
EDC/HDC Control Installation.....	50
Control Solenoids Repair.....	50
MDC Control Repair.....	51
MDC Control Assembly.....	52
Angle sensor on EDC Repair.....	53
EDC with Angle Sensor Repair.....	54
Automotive Control Repair.....	56
AC Control Installation.....	58
Shaft Seal, Roller Bearing and Shaft Repair.....	59
Charge Pump Repair.....	61
High Pressure Relief Valve Repair.....	64
Charge Pressure Relief Valve Repair.....	65
Pressure Limiter Repair.....	66

Torque Chart

Fasteners and Plugs.....	67
Fastener Size and Torque Chart.....	69
Plug Size and Torque Chart.....	69

Introduction

Hydrostatics Servicing Overview

This manual includes information on installation, maintenance, and minor repair of the . It includes a description of the unit and its individual components, troubleshooting information, and minor repair procedures.

Performing minor repairs may require the unit to be removed from the vehicle/machine. Thoroughly clean the unit before beginning maintenance or repair activities. Since dirt and contamination are the greatest enemies of any type of hydraulic equipment, follow cleanliness requirements strictly. This is especially important when changing the system filter and when removing hoses or plumbing.

A worldwide network of Danfoss Global Service Partners is available for major repairs. Danfoss trains and certifies Global Service Partners on a regular basis. You can locate your nearest Global Service Partner using the distributor locator at <http://www.danfoss.com>.





For detailed technical information about the , please see the relevant technical information document.

 **Attention**

Major repairs requiring the removal of a unit's center section, servo sleeves, or front flange voids the warranty unless a Danfoss Authorized Service Center performs them.

General Servicing Instructions

Follow these general procedures when repairing this product:

Icon	Description	Instructions
	Remove the unit	<ul style="list-style-type: none"> • If necessary, remove the unit from the vehicle/machine. • Chock the wheels on the vehicle or lock the mechanism to inhibit movement. • Be aware that hydraulic fluid may be under high pressure and/or hot. • Inspect the outside of the pump and fittings for damage. • Cap hoses after removal to prevent contamination.
	Keep it clean	<ul style="list-style-type: none"> • Cleanliness is a primary means of assuring satisfactory pump life, on either new or repaired units. • Clean the outside of the pump thoroughly before disassembly. • Take care to avoid contamination of the system ports. • Cleaning parts by using a clean solvent wash and air drying is usually adequate. • As with any precision equipment, keep all parts free of foreign materials and chemicals. • Protect all exposed sealing surfaces and open cavities from damage and foreign material. • If left unattended, cover the pump with a protective layer of plastic.
	Replace O-ring, gasket	<ul style="list-style-type: none"> • Danfoss recommends that you replace all O-rings, seals and gaskets. • Lightly lubricate all O-rings with clean petroleum jelly prior to assembly.
	Secure the unit	<ul style="list-style-type: none"> • For repair, place the unit in a stable position with the shaft pointing downward. • It will be necessary to secure the pump while removing and torquing end covers, controls, and valves.

Introduction

Safety Precautions

Always consider safety precautions before beginning a service procedure. Protect yourself and others from injury. Take the following general precautions whenever servicing a hydraulic system.

Unintended machine movement

Unintended movement of the machine or mechanism may cause injury to the technician or bystanders. Secure the machine or disable/disconnect the mechanism while servicing to protect against unintended movement.

Independent Braking System

Unintended vehicle or machine movement hazard. Exceeding maximum speed may cause a loss of hydrostatic drive line power and braking capacity.

Machine manufacturer is responsible to provide a braking system, redundant to the hydrostatic transmission, sufficient to stop and hold the vehicle or machine in the event of hydrostatic drive power loss. The braking system must also be sufficient to hold the machine in place when full power is applied.

High Inlet Vacuum

High inlet vacuum causes cavitation which can damage internal pump components.

Manufacturer's Warranty

Contamination can damage internal components and void the manufacturer's warranty.

Take precautions to ensure system cleanliness when removing and installing system lines.

Fluid Under Pressure

Escaping hydraulic fluid under pressure can have sufficient force to penetrate your skin causing serious injury and/or infection. This fluid may also be hot enough to cause burns.

Relieve pressure in the system before removing hoses, fittings, gauges, or components. Never use your hand or any other body part to check for leaks in a pressurized line. Use caution when dealing with hydraulic fluid under pressure. Seek medical attention immediately if you are cut by hydraulic fluid.

Flammable cleaning solvents

Some cleaning solvents are flammable.

Do not use cleaning solvents in an area where a source of ignition may be present to avoid possible fire.

Personal safety

Protect yourself from injury whenever servicing a hydraulic system.

Use proper safety equipment, including safety glasses, at all times.

Hazardous material

Hydraulic fluid contains hazardous material.

Avoid prolonged contact with hydraulic fluid. Always dispose of used hydraulic fluid according to state, and federal environmental regulations.

Introduction

General description of H1 family hydrostatic pumps

The H1 family of closed circuit variable displacement axial piston pumps is designed for use with all existing Danfoss hydraulic motors for the control and transfer of hydraulic power. The H1 axial piston variable displacement pumps are of cradle swash-plate design and are intended for closed circuit applications.

Flow direction is reversed by tilting the swash-plate to the opposite side of the neutral (zero displacement) position. The flow rate is proportional to the pump input speed and displacement. The latter is infinitely adjustable between zero and maximum displacement.

H1 pumps can be used together in combination with other Danfoss pumps and motors in the overall hydraulic system.

- Danfoss hydrostatic products are designed with 15 different displacements (cm³ [in³]):

045	053	060	068	069	078	089	100	115	130	147	165	210	250	280
45.0 [2.75]	53.8 [3.28]	60.4 [3.69]	68.0 [4.15]	69.0 [4.22]	78.0 [4.76]	89.2 [5.44]	101.7 [6.21]	115.8 [7.07]	130.8 [7.98]	147.0 [8.97]	165.0 [10.07]	211.5 [12.91]	251.7 [15.36]	280.2 [17.10]

- Danfoss hydrostatic products are designed with many different pressure, load-life and control capabilities:
 - Electric Displacement Control (EDC)
 - Forward-Neutral-Reverse control (FNR)
 - Non-Feedback Proportional Electric control (NFPE)
 - Automotive Control (AC)
 - Fan Drive Control (FDC)
 - Manual Displacement Control (MDC)
 - Hydraulic Displacement Control (HDC)
 - Control-Cut-Off valve (CCO)
- High power density where all units utilize an integral electro-hydraulic servo piston assembly that controls the rate (speed) and direction of the hydraulic flow.
- Compatible with the Danfoss family of PLUS+1® micro-controllers for easy Plug-and-Perform installation.
- More compact and lightweight
- Improved reliability and performance

Go to the Danfoss website or applicable product catalog to choose the components that are right for your complete closed circuit hydraulic system.

Introduction

Design

The **H1** axial piston variable displacement pumps are of cradle swashplate design and are intended for closed circuit applications.

The flow rate is proportional to the pump input speed and displacement.

The latter is infinitely adjustable between zero and maximum displacement.

Flow direction is reversed by tilting the swashplate to the opposite side of the neutral (zero displacement) position.

The H1 family of closed circuit variable displacement axial piston pumps is designed for use with all existing Danfoss hydraulic motors for the control and transfer of hydraulic power. H1 pumps are compact and high power density where all units utilize an integral electro-hydraulic servo piston assembly that controls the rate (speed) and direction of the hydraulic flow. H1 pumps are specifically compatible with the Danfoss family of PLUS+1™ microcontrollers for easy Plug-and-Perform™ installation.

H1 pumps can be used together in combination with other Danfoss pumps and motors in the overall hydraulic system. Danfoss hydrostatic products are designed with many different displacement, pressure and load-life capabilities. Go to the Danfoss website or applicable product catalog to choose the components that are right for your complete closed circuit hydraulic system.

Cross section view

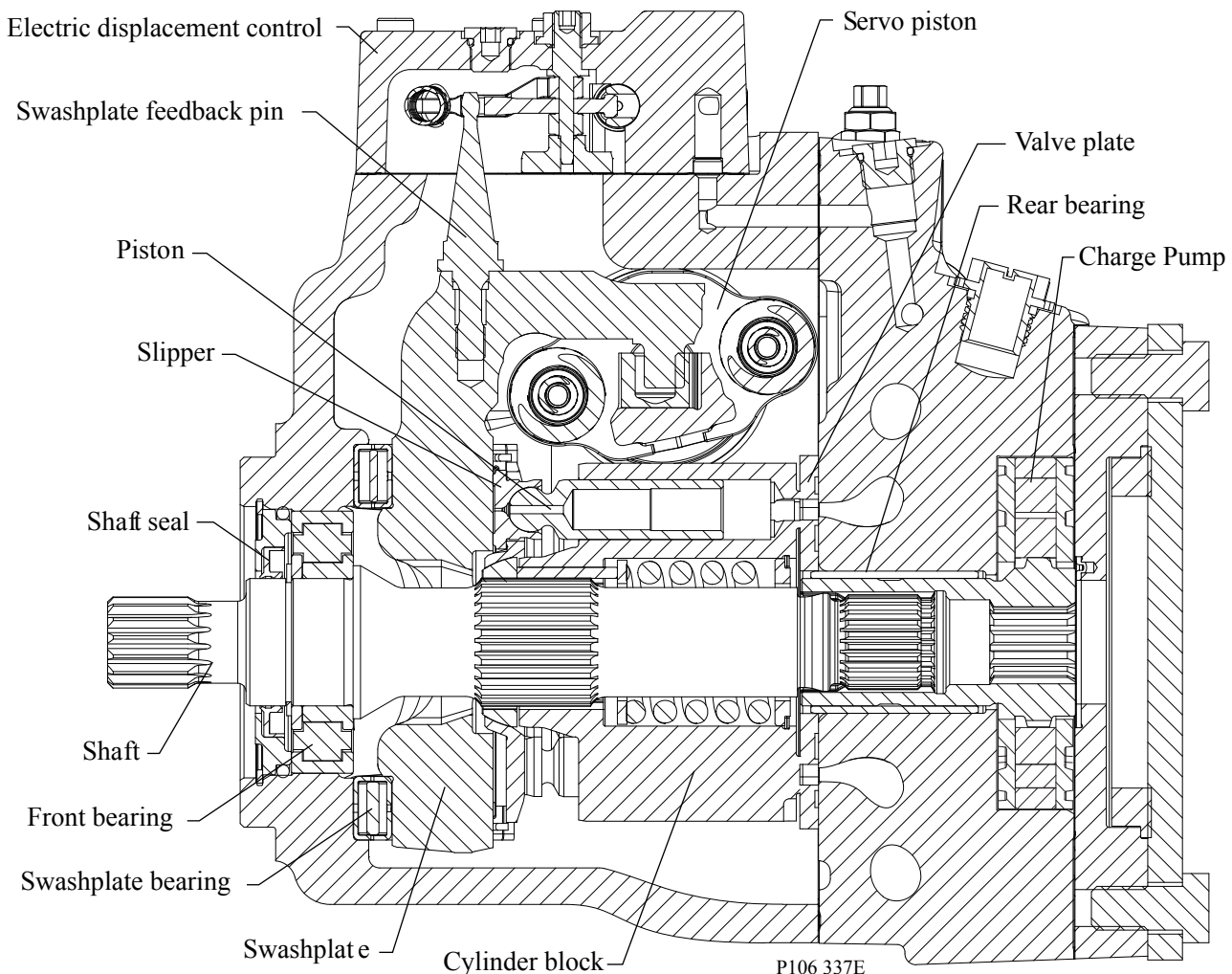

Introduction

The Basic Closed Circuit

Hydraulic lines connect the main ports of the pump to the main ports of the motor. Fluid flows in either direction from the pump to the motor and back. Either of the hydraulic lines can be under high pressure. In pumping mode the position of the pump swashplate determines which line is high pressure as well as the direction of fluid flow.

Case Drain and Heat Exchanger

The pump and motor require case drain lines to remove hot fluid from the system. The pump and motor drain from the topmost port to ensure the cases remain full of fluid.

The motor case drain can connect to the lower drain port on the pump housing or it can tee into the case drain line upstream of the heat exchanger. A heat exchanger with bypass valve cools the case drain fluid before it returns to the reservoir.

H1 Single Pumps Closed Circuit Pictorial Diagram

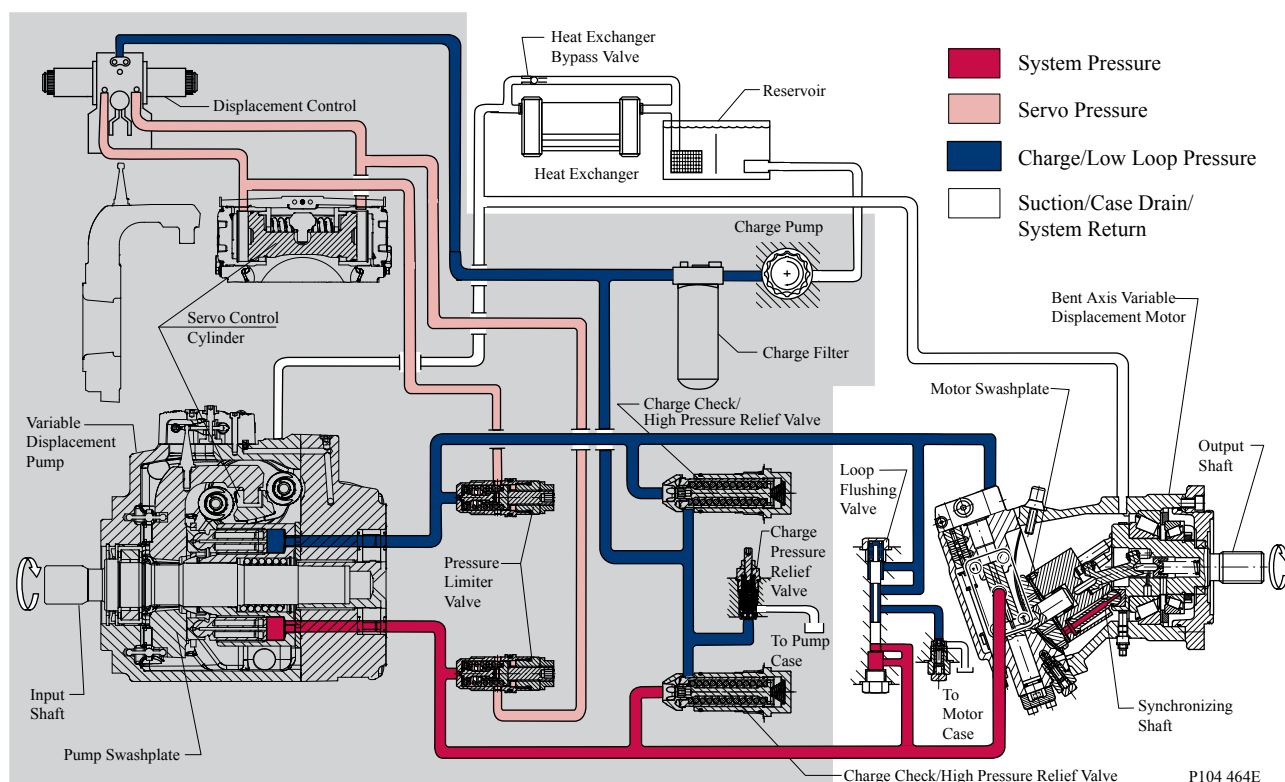

Introduction

H1 system schematic

System schematic H1 pump and H1 motor with EDC

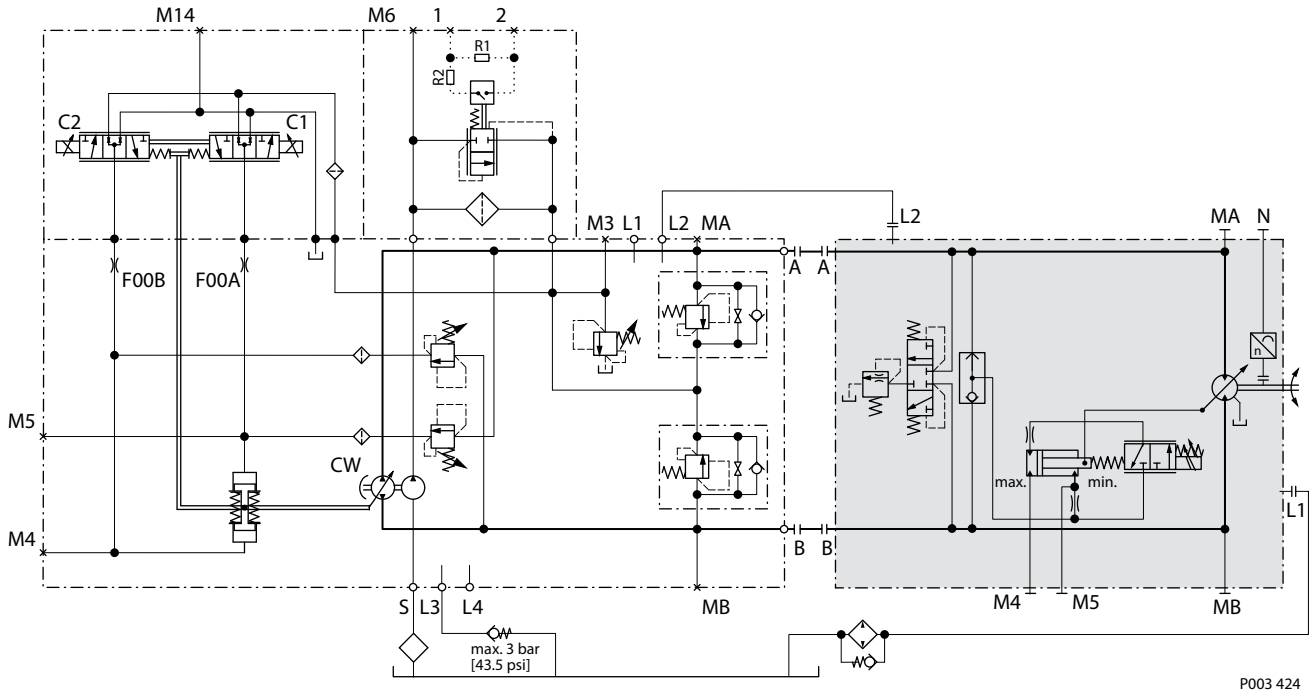

The schematic above shows the function of a hydrostatic transmission using an H1 axial variable displacement pump with electric proportional displacement control (EDC) and an H1 bent axis variable displacement motor with electric proportional control (L*) and integrated loop flushing device.

Operation

Pressure Limiter Valves

Pressure limiter valves provide system pressure protection by compensating the pump swash plate position when the set pressure of the valve is reached. A pressure limiter is a non-dissipative (non heat generating) pressure regulating system.

Each side of the transmission loop has a dedicated pressure limiter valve that is set independently. A pump configured with pressure limiter must have pressure limiters on both sides of the system pressure loop. The pump order code allows for different pressure settings to be used at each system port.

The pressure limiter setting is the maximum differential pressure between the high and low loops. When the pressure limiter setting is reached, the valve ports oil to the low-pressure side of the servo piston. The change in servo differential pressure rapidly reduces pump displacement. Fluid flow from the valve continues until the resulting drop in pump displacement causes system pressure to fall below the pressure limiter setting.

An active pressure limiter destrokes a pump to near neutral when the load is in a stalled condition. The pump swash-plate moves in either direction necessary to regulate the system pressure, including into stroke (overrunning) or over-center (winch payout).

The pressure limiter is optional on H1 pumps (except H1T 045/053 tandem pumps).

Pressure Limiter Sectional View

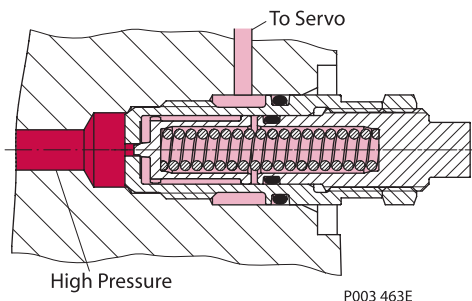

Operation

High Pressure Relief Valve (HPRV) and Charge Check Valve

All H1 pumps have a combination high pressure relief and charge check valve. The high pressure relief function is a dissipative (heat generating) pressure control valve for the purpose of limiting excessive system pressures. The charge check function replenishes the low pressure side of the working loop with charge oil.

Each side of the transmission loop has a dedicated HPRV valve that is non-adjustable with a factory set pressure. When system pressure exceeds the factory setting of the valve, oil is passed from the high pressure system loop, into the charge gallery, and into the low pressure system loop via the charge check.

The pump may have different pressure settings to be used at each system port. When an HPRV valve is used in conjunction with a pressure limiter, the HPRV valve is always factory set above the setting of the pressure limiter. The system pressure shown in the order code for pumps with only HPRV is the HPRV setting.

The system pressure shown in the order code for pumps with pressure limiter and HPRV is a reflection of the pressure limiter setting:

HPRVs are set at low flow condition. Any application or operating condition which leads to elevated HPRV flow will cause a pressure rise with flow above the valve setting. Consult factory for application review.

Excessive operation of the HPRV will generate heat in the closed loop and may cause damage to the internal components of the pump.

HPRV/Charge Check Valve Sectional View

HPRV and Charge Check Valve with Bypass Function (except 045/053)

Relief mode

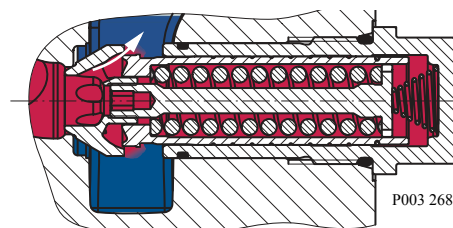

Operation

Charge Pressure Relief Valve (CPRV)

The charge pressure relief valve is a direct acting poppet valve that opens and discharges fluid to the pump case when pressure exceeds a designated level. The charge pressure relief valve maintains charge pressure at a designated level above case pressure.

This level is nominally set with the pump running at 1800 min^{-1} (rpm), and with a fluid viscosity of $32 \text{ mm}^2/\text{s}$ [150 SUS]. In forward or reverse, charge pressure will be slightly lower than in neutral position. The model code of the pump specifies the charge pressure relief valve setting. Typical charge pressure increase from 1.2-1.5 bar per 10 l/min [17.4-21.8 psi per 2.64 US gal/min]. For external charge flow the CPRV is set according to the table below:

CPRV flow setting for external charge supply

Tandem 045/053	Single 045/053	Single 060—165	Single 210/250/280
30 l/min [7.9 US gal/min]	15 l/min [3.9 US gal/min]	22.7 l/min [6.0 US gal/min]	40.0 l/min [10.6 US gal/min]

Charge pressure relief valve

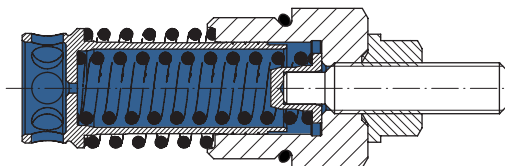

Operation

Bypass function

The bypass function allows a machine or load to be moved without rotating the pump shaft or prime mover. The single pump HPRV valve also provides a loop bypass function when each of the two HPRV hex plugs are mechanically backed out three full turns.

Engaging the bypass function mechanically connects both A & B sides of the working loop to the common charge gallery.

Possible damage to hydromotor(s).

Excessive speeds and extended load/vehicle movement must be avoided. The load or vehicle should be moved not more than 20% of maximum speed and for a duration not exceeding 3 minutes. When the bypass function is no longer needed, care should be taken to re-seat the HPRV hex plugs to the normal operating position.

Bypass function not available for tandem pumps.

System Schematic for Single Pump

The schematic below shows the function of an H1P axial piston variable displacement pump with electric displacement control (EDC).

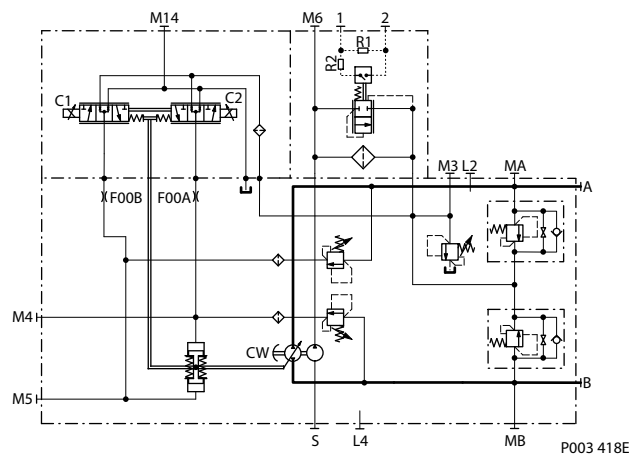

Operation

Electrical Displacement Control (EDC)

An EDC is a displacement (flow) control. Pump swash plate position is proportional to the input command and therefore vehicle or load speed (excluding influence of efficiency), is dependent only on the prime mover speed or motor displacement.

The Electrical Displacement Control (**EDC**) consists of a pair of proportional solenoids on each side of a three-position, four-way porting spool. The proportional solenoid applies a force input to the spool, which ports hydraulic pressure to either side of a double acting servo piston. Differential pressure across the servo piston rotates the swash plate, changing the pump's displacement from full displacement in one direction to full displacement in the opposite direction.

A serviceable 170 μ m screen is located in the supply line immediately before the control porting spool.

Under some circumstances, such as contamination, the control spool could stick and cause the pump to stay at some displacement.

Electrical Displacement Control

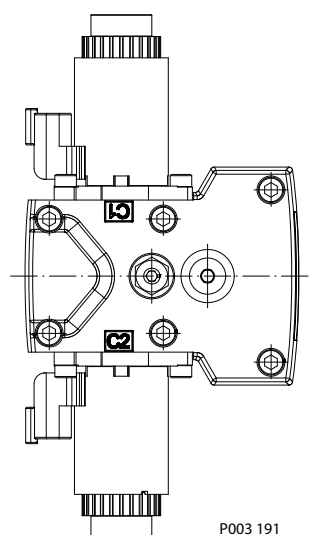

EDC schematic, feedback from swash plate

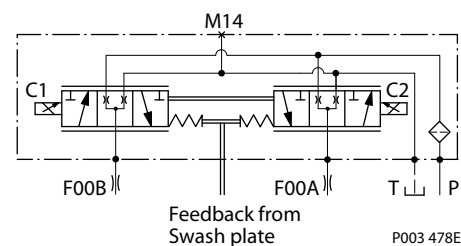

Operation

EDC Operation

H1 EDC's are current driven controls requiring a Pulse Width Modulated (PWM) signal. Pulse width modulation allows more precise control of current to the solenoids.

The PWM signal causes the solenoid pin to push against the porting spool, which pressurizes one end of the servo piston, while draining the other. Pressure differential across the servo piston moves the swashplate.

A swashplate feedback link, opposing control links, and a linear spring provide swashplate position force feedback to the solenoid. The control system reaches equilibrium when the position of the swashplate spring feedback force exactly balances the input command solenoid force from the operator. As hydraulic pressures in the operating loop change with load, the control assembly and servo/swashplate system work constantly to maintain the commanded position of the swashplate.

The EDC incorporates a positive neutral deadband as a result of the control spool porting, preloads from the servo piston assembly, and the linear control spring. Once the neutral threshold current is reached, the swashplate is positioned directly proportional to the control current. To minimize the effect of the control neutral deadband, we recommend the transmission controller or operator input device incorporate a jump up current to offset a portion of the neutral deadband.

The neutral position of the control spool does provide a positive preload pressure to each end of the servo piston assembly.

When the control input signal is either lost or removed, or if there is a loss of charge pressure, the spring-loaded servo piston will automatically return the pump to the neutral position.

Operation

Hydraulic Displacement Control (HDC)

HDC principle

An HDC is a Hydraulic Displacement Control. Pump swashplate position is proportional to the input command and therefore vehicle speed or load speed (excluding influence of efficiency), is dependent only on the prime mover speed or motor displacement.

The HDC control uses a hydraulic input signal to operate a porting spool, which ports hydraulic pressure to either side of a double acting servo piston. The hydraulic signal applies a force input to the spool which ports hydraulic pressure to either side of a double acting servo piston. Differential pressure across the servo piston rotates the swashplate, changing the pump's displacement from full displacement in one direction to full displacement in the opposite direction. Under some circumstances, such as contamination, the porting spool could stick and cause the pump to stay at some displacement.

A serviceable 175 µm screen is located in the supply line immediately before the control porting spool.

HDC control

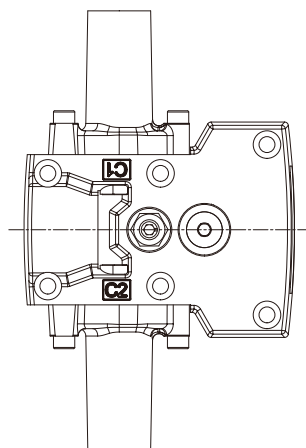

P400520

HDC schematic

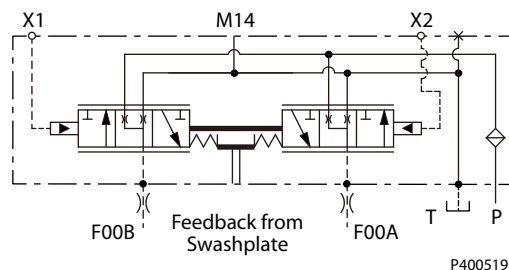

P400519

HDC operation

HDC's are hydraulically driven control which ports hydraulic pressure to either side of a porting spool, which pressurizes one end of the servo piston, while draining the other end to case. Pressure differential across the servo piston moves the swashplate.

A swashplate feedback link, opposing control linkage, and a linear spring provide swashplate position force feedback to the hydraulic pressure. As hydraulic pressures in the operating loop change with load, the control assembly and servo/swashplate system work constantly to maintain the commanded position of the swashplate.

Operation

The HDC incorporates a positive neutral dead band as a result of the control spool porting, preloads from the servo piston assembly, and the linear control spring. Once the neutral threshold point is reached, the swashplate is positioned directly proportional to the control pressure.

When the control input is either lost or removed, or if there is a loss of charge pressure, the spring loaded servo piston will automatically return the pump to the neutral position.

Pump displacement vs signal pressure

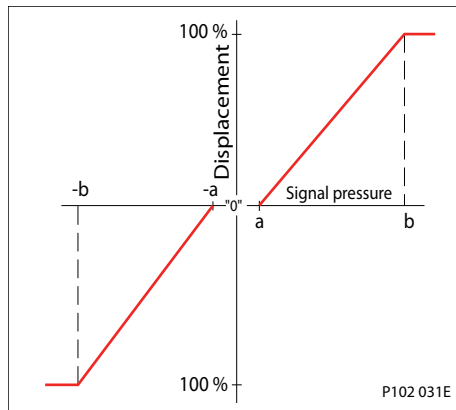

Operation

Manual Override (MOR)

All controls are available with a manual override functionality, either as a standard or as an option for temporary actuation of the control to aid in diagnostics.

Control with manual override

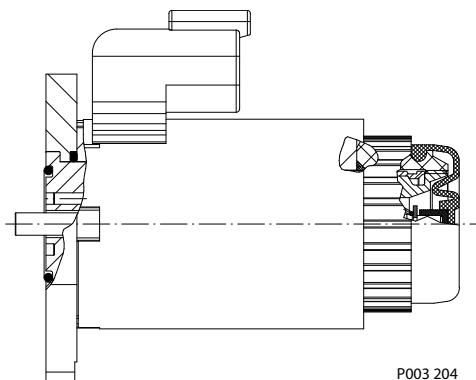

MOR schematic (EDC control shown)

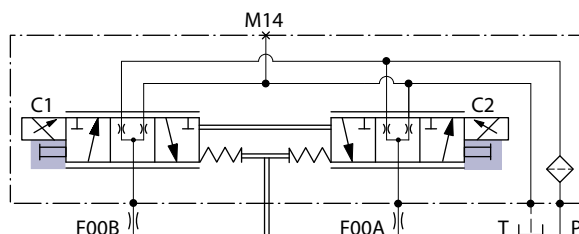

Feedback from swash plate.

The MOR plunger has a 4 mm diameter and must be manually depressed to be engaged. Depressing the plunger mechanically moves the control spool which allows the pump to go on stroke. The MOR should be engaged anticipating a full stroke response from the pump.

An o-ring seal is used to seal the MOR plunger where initial actuation of the function will require a force of 45 N to engage the plunger. Additional actuation typically require less force to engage the MOR plunger.

Proportional control of the pump using the MOR should not be expected.

Warning

Unintended MOR operation will cause the pump to go into stroke; *example: vehicle lifted off the ground.* The vehicle or device must always be in a safe condition when using the MOR function.

Refer to control flow table for the relationship of solenoid to direction of flow.

Operation

Manual Displacement Control (MDC)

A Manual proportional Displacement Control (**MDC**) consists of a handle on top of a rotary input shaft. The shaft provides an eccentric connection to a feedback link. This link is connected on its one end with a porting spool. On its other end the link is connected the pumps swashplate.

This design provides a travel feedback without spring. When turning the shaft the spool moves thus providing hydraulic pressure to either side of a double acting servo piston of the pump.

Differential pressure across the servo piston rotates the swash plate, changing the pump's displacement. Simultaneously the swashplate movement is fed back to the control spool providing proportionality between shaft rotation on the control and swash-plate rotation. The MDC changes the pump displacement between no flow and full flow into opposite directions.

Under some circumstances, such as contamination, the control spool could stick and cause the pump to stay at some displacement.

For the MDC with CCO option the brake port (X7) provides charge pressure when the coil is energized to activate static function such as a brake release. The X7 port must not be used for any continuous oil consumption.

The MDC is sealed by means of a static O-ring between the actuation system and the control block. Its shaft is sealed by means of a special O-ring which is applied for low friction. The special O-ring is protected from dust, water and aggressive liquids or gases by means of a special lip seal.

Manual Displacement Control

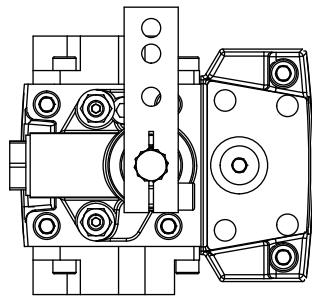

Pump displacement vs. control lever rotation

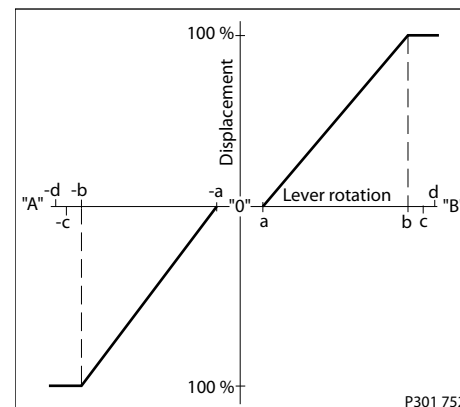

Deadband on **B** side: $a = 3^\circ \pm 1^\circ$

Maximum pump stroke: $b = 30^\circ + 2/-1^\circ$

Required customer end stop: $c = 36^\circ \pm 3^\circ$

Internal end stop: $d = 40^\circ$

MDC operation

The MDC provides a mechanical dead-band required to overcome the tolerances in the mechanical actuation. The MDC contains an internal end stop to prevent turning the handle into any inappropriate position.

The MDC provides a permanent restoring moment appropriate for turning the MDC input shaft back to neutral position only. This is required to take the backlash out of the mechanical connections between the Bowden cable and the control.

High case pressure may cause excessive wear and the NSS to indicate that the control is not in neutral position. In addition, if the case pressure exceeds 5 bar there is a risk of an insufficient restoring moment. The MDC is designed for a maximum case pressure of 5 bar and a rated case pressure of 3 bar.

Operation

- Customers must install some support to limit the setting range of their Bowden cable to avoid an overload of the MDC.
- Customers can apply their own handle design but they must care about a robust clamping connection between their handle and the control shaft and avoid overload of the shaft.
- Customers can connect two MDC's on a tandem unit in such a way that the actuation force will be transferred from the pilot control to the second control. The kinematic of the linkages must ensure that either control shaft is protected from torque overload.

! Caution

Using the internal spring force on the input shaft is not an appropriate way to return the customer connection linkage to neutral, or to force a Bowden cable or a joystick back to neutral position. It is not applicable for any limitation of the Bowden cable stroke, except the applied torque to the shaft will never exceed 20 N·m.

MDC Torque

Description	Value
Torque required to move handle to maximum displacement	1.4 N·m [12.39 lbf·in]
Torque required to hold handle at given displacement	0.6 N·m [5.31 lbf·in]
Maximum allowable input torque	20 N·m [177 lbf·in]

! Caution

Volumetric efficiencies of the system will have impacts on the start and end input commands.

Neutral start switch (NSS)

The Neutral Start Switch (NSS) contains an electrical switch that provides a signal of whether the control is in neutral. The signal in neutral is Normally Closed (NC).

Neutral start switch schematic

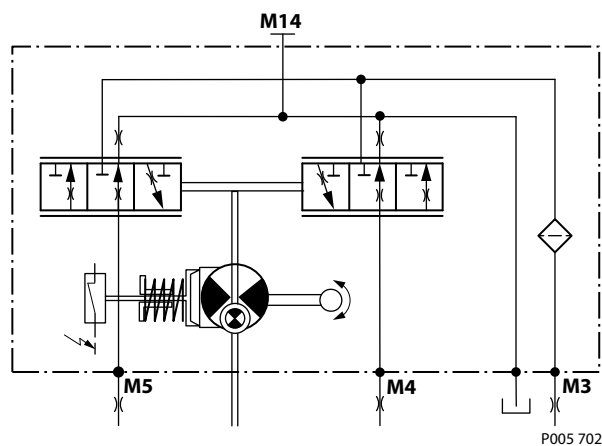

Neutral start switch data

Max. continuous current with switching	8.4 A
Max. continuous current without switching	20 A
Max. voltage	36 V _{DC}
Electrical protection class	IP67 / IP69K with mating connector

Operation

Case Gauge Port M14

The drain port should be used when the control is mounted on the unit's bottom side to flush residual contamination out of the control.

Operating Parameters

Input Speed

Minimum speed	is the lowest input speed recommended during engine idle condition. Operating below minimum speed limits the pump's ability to maintain adequate flow for lubrication and power transmission.
Rated speed	is the highest input speed recommended at full power condition. Operating at or below this speed should yield satisfactory product life. Operating conditions between rated and maximum speed should be restricted to less than full power and to limited periods of time.
Maximum speed	is the highest operating speed permitted. Exceeding maximum speed reduces product life and can cause loss of hydrostatic power and braking capacity. For most drive systems, maximum unit speed occurs during downhill braking or negative power conditions.

 **Warning**

Never exceed the maximum speed limit under any operating conditions.

During hydraulic braking and downhill conditions, the prime mover must be capable of providing sufficient braking torque in order to avoid pump over speed. This is especially important to consider for turbo-charged and Tier 4 engines.

For more information please see *Pressure and Speed Limits, BC152886484313*, when determining speed limits for a particular application.

Independent Braking System

Unintended vehicle or machine movement hazard. Exceeding maximum speed may cause a loss of hydrostatic drive line power and braking capacity.
Machine manufacturer is responsible to provide a braking system, redundant to the hydrostatic transmission, sufficient to stop and hold the vehicle or machine in the event of hydrostatic drive power loss. The braking system must also be sufficient to hold the machine in place when full power is applied.

System Pressure

Hydraulic unit life depends on the speed and normal operating — or weighted average — pressure that can only be determined from a duty cycle analysis.

System pressure	is the differential pressure between high pressure system ports. It is the dominant operating variable affecting hydraulic unit life. High system pressure, which results from high load, reduces expected life.
Application pressure	is the high pressure relief or pressure limiter setting normally defined within the order code of the pump. This is the applied system pressure at which the drive line generates the maximum calculated pull or torque in the application.
Maximum working pressure	is the highest recommended application pressure and is not intended to be a continuous pressure. Propel systems with application pressures at, or below this pressure should yield satisfactory unit life given proper component sizing. Application pressures above maximum working pressure will only be considered with duty cycle analysis and factory approval.

Pressure spikes are normal and must be considered when reviewing maximum working pressure.

Operating Parameters

Maximum pressure is the highest intermittent pressure allowed under any circumstances. Applications with applied pressures between rated and maximum require factory approval with complete application, duty cycle, and life expectancy analysis.

Minimum low loop pressure must be maintained under all operating conditions to avoid cavitation.

All pressure limits are differential pressures referenced to low loop (charge) pressure. Subtract low loop pressure from gauge readings to compute the differential.

Servo Pressure

Servo pressure is the pressure in the servo system needed to position and hold the pump on stroke. It depends on system pressure and speed. At minimum servo pressure the pump will run at reduced stroke depending on speed and pressure.

Minimum servo pressure at corner power holds the pump on full stroke at max speed and max pressure.

Maximum servo pressure is the highest pressure typically given by the charge pressure setting.

Charge Pressure

An internal charge relief valve regulates charge pressure. Charge pressure supplies the control with pressure to operate the swashplate and to maintain a minimum pressure in the low side of the transmission loop.

The charge pressure setting listed in the order code is the set pressure of the charge relief valve with the pump in neutral, operating at 1800 min⁻¹ (rpm), and with a fluid viscosity of 32 mm²/s [150 SUS].

Pumps configured with no charge pump (external charge supply) are set with a charge flow of 30 l/min [7.93 US gal/min] and a fluid viscosity of 32 mm²/s [150 SUS].

The charge pressure setting is referenced to case pressure. Charge pressure is the differential pressure above case pressure.

Minimum charge pressure is the lowest pressure allowed to maintain a safe working condition in the low side of the loop. Minimum control pressure requirements are a function of speed, pressure, and washplate angle, and may be higher than the minimum charge pressure shown in the Operating parameters tables.

Maximum charge pressure is the highest charge pressure allowed by the charge relief adjustment, and which provides normal component life. Elevated charge pressure can be used as a secondary means to reduce the swashplate response time.

Charge Pump Inlet Pressure

At normal operating temperature charge inlet pressure must not fall below rated charge inlet pressure (vacuum).

Minimum charge inlet pressure is only allowed at cold start conditions. In some applications it is recommended to warm up the fluid (e.g. in the tank) before starting the engine and then run the engine at limited speed.

Maximum charge inlet pressure may be applied continuously.

Operating Parameters

Case Pressure

Under normal operating conditions, the rated case pressure must not be exceeded. During cold start case pressure must be kept below maximum intermittent case pressure. Size drain plumbing accordingly.

The auxiliary pad cavity of axial pumps configured without integral charge pumps is referenced to case pressure. Units with integral charge pumps have auxiliary mounting pad cavities referenced to charge inlet (vacuum).

Possible component damage or leakage.

Operation with case pressure in excess of stated limits may damage seals, gaskets, and/or housings, causing external leakage. Performance may also be affected since charge and system pressure are additive to case pressure.

External Shaft Seal Pressure

In certain applications the input shaft seal may be exposed to external pressure. In order to prevent damage to the shaft seal the maximum differential pressure from external sources must not exceed 0.4 bar (5.8 psi) over pump case pressure.

The case pressure limits of the pump must also be followed to ensure the shaft seal is not damaged.

! Caution

Regardless of the differential pressure across the shaft seal, the shaft seal has been known to pump oil from the external source (e. g. gear box) into the pump case.

Temperature

The high temperature limits apply at the hottest point in the transmission, which is normally the motor case drain. The system should generally be run at or below the quoted **rated temperature**.

The **maximum intermittent temperature** is based on material properties and should never be exceeded.

Cold oil will generally not affect the durability of the transmission components, but it may affect the ability of oil to flow and transmit power; therefore temperatures should remain 16 °C [30 °F] above the pour point of the hydraulic fluid.

The **minimum temperature** relates to the physical properties of component materials.

Size heat exchangers to keep the fluid within these limits. Danfoss recommends testing to verify that these temperature limits are not exceeded.

Viscosity

For maximum efficiency and bearing life, ensure the fluid viscosity remains in the **recommended range**.

The **minimum viscosity** should be encountered only during brief occasions of maximum ambient temperature and severe duty cycle operation.

The **maximum viscosity** should be encountered only at cold start.

Technical Specifications

H1 Pumps General Specification

Axial piston closed circuit variable displacement pumps of cradle swash-plate design with clockwise or counterclockwise direction of rotation.

Pipe connections

- Main pressure ports: ISO split flange boss
- Remaining ports: SAE straight thread O-ring boss

Recommended installation position

Pump installation position is discretionary, however the recommended control position is on the top or at the side with the top position preferred. If the pump is installed with the control at the bottom, flushing flow must be provided through port M14 located on the EDC, FNR and NFPE control.

Vertical input shaft installation is acceptable. If input shaft is at the top, 1 bar case pressure must be maintained during operation. The housing must always be filled with hydraulic fluid. Recommended mounting for a multiple pump stack is to arrange the highest power flow towards the input source. Consult Danfoss for nonconformance to these guidelines.

Auxiliary cavity pressure

Auxiliary cavity pressure will be inlet pressure with internal charge pump or case pressure with external charge supply. For reference see Operating Parameters. Please verify mating pump shaft seal capability.

H1 Pumps Physical Properties

Frame size	045/053	060/068
Mounting flange	ISO 3019-1 flange 101-2 (SAE B) Special bolt dia.	ISO 3019-1 flange 127-4 (SAE C)
Input shaft outer diameter, splines and tapered shafts	ISO 3019-1, outer Ø22 mm -4 (SAE B, 13 teeth) ISO 3019-1, outer Ø25 mm -4 (SAE B-B, 15 teeth) ISO 3019-1, outer Ø32 mm -4 (SAE B, 14 teeth) Conical keyed shaft end similar to ISO 3019-1 code 25-3 taper 1:8	ISO 3019-1, outer Ø32 mm -4 (SAE C, 14 teeth) ISO 3019-1, outer Ø35 mm -4 (SAE C, 21 teeth)
Auxiliary mounting flange with metric fasteners per ISO 3019-1, shaft outer diameter and splines	Flange 82-2, outer Ø16 mm -4 (SAE A, 9 teeth) Flange 82-2, outer Ø19 mm -4 (SAE A, 11 teeth) Flange 101-2, outer Ø22 mm -4 (SAE B, 13 teeth) Flange 101-2, outer Ø25 mm -4 (SAE B-B, 15 teeth)	Flange 82-2, outer Ø16 mm -4 (SAE A, 9 teeth) Flange 82-2, outer Ø19 mm -4 (SAE A, 11 teeth) Flange 101-2, outer Ø22 mm -4 (SAE B, 13 teeth) Flange 101-2, outer Ø25 mm -4 (SAE B-B, 15 teeth) Flange 127-2, outer Ø32 mm -4 (SAE C, 14 teeth)
Suction port	ISO 11926-1 – 1 5/16 -12 (SAE O-ring boss)	
Main port configuration	Ø19.0 - 450 bar split flange boss per ISO 6162, M10x1.5 ISO 11926-1 – 1 5/16 -12 (SAE O-ring boss)	Ø25.4 - 450 bar split flange boss per ISO 6162, M12x1.75
Case drain ports L1, L2, L4	ISO 11926-1 – 1 1/16 -12 (SAE O-ring boss)	
Other ports	SAE O-ring boss. See installation drawings.	
Customer interface threads	Metric fasteners	

Technical Specifications

Fluid Specification

Viscosity

Intermittent¹⁾	5 mm ² /s [42 SUS]
Minimum	7 mm ² /s [49 SUS]
Recommended range	12 – 80 mm ² /s [66 – 370 SUS]
Maximum	1600 mm ² /s [7500 SUS]

¹⁾ Intermittent = Short term $t < 1$ min per incident and not exceeding 2 % of duty cycle based load-life.

Temperature

Minimum ¹⁾	-40°C [-40°F]
Rated	104°C [220°F]
Recommended range²⁾	60 – 85°C [140 – 185°F]
Maximum Intermittent	115°C [240°F]

¹⁾ Cold start = Short term $t > 3$ min, $p \leq 50$ bar [725 psi], $n \leq 1000$ min⁻¹ (rpm).

²⁾ At the hottest point, normally case drain port.

Fluid and Filter Maintenance Recommendations

To ensure optimum life perform regular maintenance of the fluid and filter. Contaminated fluid is the main cause of unit failure. Take care to maintain fluid cleanliness when servicing.

- Check the reservoir daily for proper fluid level, the presence of water, and rancid fluid odor. Fluid contaminated by water may appear cloudy or milky or free water may settle in the bottom of the reservoir. Rancid odor indicates the fluid has been exposed to excessive heat. Change the fluid and correct the problem immediately if these conditions occur.
- Inspect vehicle for leaks daily. Change the fluid and filter per the vehicle/machine manufacturer's recommendations or at intervals shown in the table. We recommend first fluid change at 500 hours.

Fluid and filter change interval

Reservoir type	Max oil change interval
Sealed	2000 hours
Breather	500 hours

[High temperatures and pressures will result in accelerated fluid aging. More frequent fluid changes may be required.](#)

- Change the fluid more frequently if it becomes contaminated with foreign matter (dirt, water, grease, etc.) or if the fluid is subjected to temperature levels greater than the recommended maximum.
- Dispose of used hydraulic fluid properly. Never reuse hydraulic fluid.
- Change filters with the fluid or when the filter indicator shows it's necessary.
- Replace all fluid lost during filter change.

 **Caution**

Hydraulic fluid contains hazardous material.
 Avoid contact with hydraulic fluid. Always dispose of used hydraulic fluid according to state and federal environmental regulations.

For further information see Danfoss publication *Technical Information, Hydraulic Fluids and Lubricants, BC0000093*.

Fluid and Filter Maintenance Recommendations

Filtration System

To prevent premature wear, ensure only clean fluid enters the hydrostatic transmission circuit. A filter capable of controlling the fluid cleanliness to ISO 4406 class 22/18/13 (SAE J1165) or better, under normal operating conditions, is recommended.

These cleanliness levels can not be applied for hydraulic fluid residing in the component housing/case or any other cavity after transport.

The filter may be located on the pump (integral) or in another location (remote). The integral filter has a filter bypass sensor to signal the machine operator when the filter requires changing. Filtration strategies include suction or pressure filtration.

The selection of a filter depends on a number of factors including the contaminant ingress rate, the generation of contaminants in the system, the required fluid cleanliness, and the desired maintenance interval. Filters are selected to meet the above requirements using rating parameters of efficiency and capacity.

Filter efficiency can be measured with a Beta ratio (β_x). For simple suction filtered closed circuit transmissions and open circuit transmissions with return line filtration, a filter with a β -ratio within the range of $\beta_{35-45} = 75$ ($\beta_{10} \geq 2$) or better has been found to be satisfactory.

For some open circuit systems, and closed circuits with cylinders being supplied from the same reservoir, a considerably higher filter efficiency is recommended. This also applies to systems with gears or clutches using a common reservoir.

For these systems, a charge pressure or return filtration system with a filter β -ratio in the range of $\beta_{15-20} = 75$ ($\beta_{10} \geq 10$) or better is typically required.

Because each system is unique, only a thorough testing and evaluation program can fully validate the filtration system.

Please see *Design Guidelines for Hydraulic Fluid Cleanliness Technical Information*, **BC152886482150** for more information.

Filter β_x -ratio is a measure of filter efficiency defined by ISO 4572. It is defined as the ratio of the number of particles greater than a given diameter (" x " in microns) upstream of the filter to the number of these particles downstream of the filter.

Filtration, cleanliness level and β_x -ratio (recommended minimum)

Cleanliness per ISO 4406	22/18/13
Efficiency β_x (charge pressure filtration)	$\beta_{15-20} = 75$ ($\beta_{10} \geq 10$)
Efficiency β_x (suction and return line filtration)	$\beta_{35-45} = 75$ ($\beta_{10} \geq 2$)
Recommended inlet screen mesh size	100 – 125 μm

Pressure Measurements

Port Locations and Gauge Installation

When testing system pressures, calibrate pressure gauges frequently to ensure accuracy. Use snubbers to protect gauges. The drawing and following table show the port locations and gauge sizes needed.

Port locations

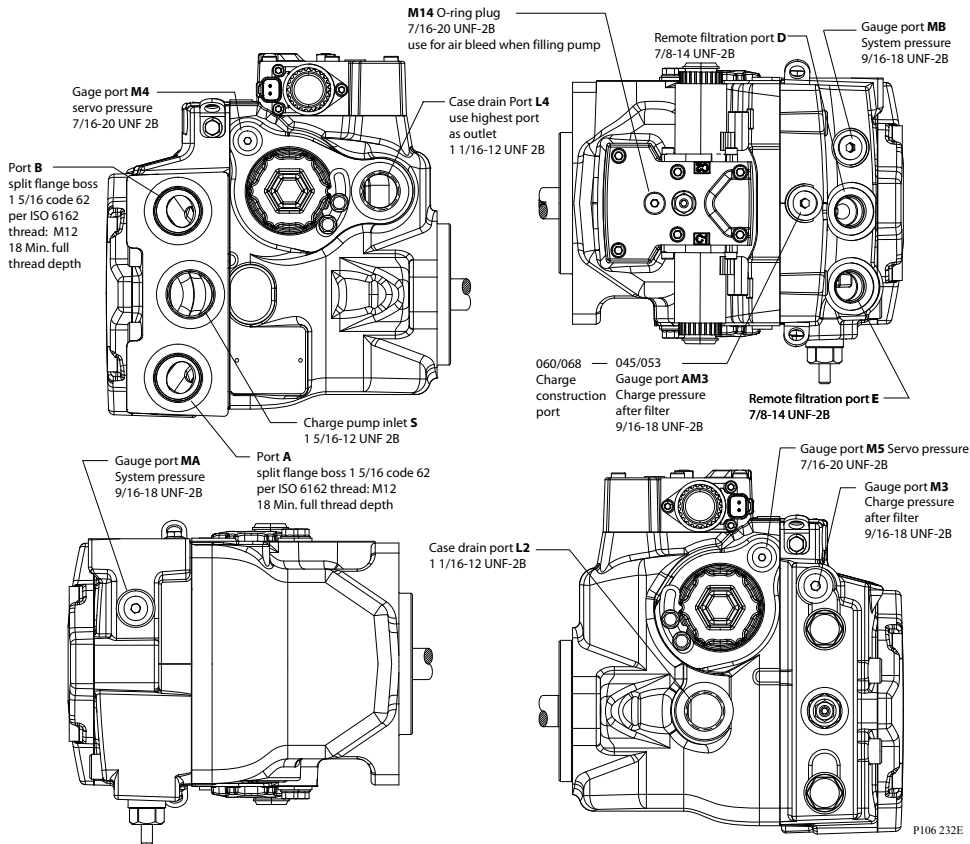

H1P Ports Information

Port identifier	Port size	Wrench size	Pressure obtained	Gauge pressure
MA, MB,	9/16-18 UNF	1/4 internal hex	System pressure	600 bar [10,000 psi]
L2, L4	1 1/16-12 UNF 2B	9/16 internal hex	Case drain	10 bar [100 psi]
M3; AM3 (045/053) Alternate	9/16-18 UNF 2B	1/4 internal hex	Charge pressure	50 bar [1000 psi]
M4, M5, M14	7/16-20 UNF 2B	3/16 internal hex	Servo pressure	

Initial Startup Procedures

Unintended machine movement

Unintended movement of the machine or mechanism may cause injury to the technician or bystanders. Secure the machine or disable/disconnect the mechanism while servicing to protect against unintended movement.

Start-Up Procedure

Prior to installing the pump, inspect for damage that may have occurred during shipping.

Follow this procedure when starting-up a new pump installation or when restarting an installation in which the pump has been removed and re-installed on a machine. Ensure pump has been thoroughly tested on a test stand before installing on a machine.

! Caution

M12X1.75 or ½" screws with hardened washer (ASTM F436M or ISO 7089 300HV) must be used to mount the pump. Using M14 screws may cause issues when mounting.

1. Ensure that the machine hydraulic oil and system components (reservoir, hoses, valves, fittings, and heat exchanger) are clean and free of any foreign material.
2. Install new system filter element(s) if necessary. Check that inlet line fittings are properly tightened and there are no air leaks.
3. Install the pump and a 50 bar [1000 psi] gauge in the charge pressure gauge port M.
4. Fill the housing by adding filtered oil in the upper case drain port.
If the control is installed on top, open the construction plug in the top of the control to assist in air bleed.
5. Fill the reservoir with hydraulic fluid of the recommended type and viscosity; fill inlet line from reservoir to pump.
Use a 10-micron filler filter.
6. Disconnect the pump from all control input signals.

Do not disconnect a FDC control from control input signals. Due to the fail safe function the pump will stroke in case of sufficient servo pressures. During start up provide a signal to keep the pump in neutral.

7. Close construction plug removed in the step 4.

! Caution

After start-up the fluid level in the reservoir may drop due to system components filling. Damage to hydraulic components may occur if the fluid supply runs out. Ensure reservoir remains full of fluid during start-up. Air entrapment in oil under high pressure may damage hydraulic components. Check carefully for inlet line leaks. Do not run at maximum pressure until system is free of air and fluid has been thoroughly filtered.

8. Use a common method to disable the engine to prevent it from starting.
9. Crank the starter for several seconds.

! Caution

Do not to exceed the engine manufacturer's recommendation. Wait 30 seconds and then crank the engine a second time as stated above.

This operation helps to remove air from the system lines.

10. Refill the reservoir to recommended fluid level.
11. When the gauge begins to register charge pressure, enable and start engine.
Let the engine run for a minimum of 30 seconds at low idle to allow the air to work itself out of the system.
12. Check for leaks at all line connections and listen for cavitation.

Initial Startup Procedures

- 13.** Check for proper fluid level in the reservoir.
- 14.** Increase engine speed to normal operating rpm to further purge residual air from the system, when adequate charge pressure is established (as shown in model code).
- 15.** Shut off the engine.
- 16.** Connect pump control signal.
- 17.** Start engine, checking to be certain pump remains in neutral. Run engine at normal operating speed and carefully check for forward and reverse control operation.
- 18.** Continue to cycle between forward and reverse for at least five minutes to bleed all air and flush system contaminants out of the system loop.

Normal charge pressure fluctuation may occur during forward and reverse operation.

- 19.** Check that the reservoir is full and remove charge pressure gauge.
The pump is now ready for an operation.

Troubleshooting

This section provides troubleshooting steps to follow if you are having problems with your machine until you solve the problem. Some of the troubleshooting items are system specific. Always observe the safety precautions listed in the Introduction section and precautions related to your specific equipment.

High Inlet Vacuum

High inlet vacuum causes cavitation which can damage internal pump components.

Unintended machine movement

Unintended movement of the machine or mechanism may cause injury to the technician or bystanders. Secure the machine or disable/disconnect the mechanism while servicing to protect against unintended movement.

Fluid Under Pressure

Escaping hydraulic fluid under pressure can have sufficient force to penetrate your skin causing serious injury and/or infection. This fluid may also be hot enough to cause burns. Relieve pressure in the system before removing hoses, fittings, gauges, or components. Never use your hand or any other body part to check for leaks in a pressurized line. Use caution when dealing with hydraulic fluid under pressure. Seek medical attention immediately if you are cut by hydraulic fluid.

Hazardous material

Hydraulic fluid contains hazardous material. Avoid prolonged contact with hydraulic fluid. Always dispose of used hydraulic fluid according to state, and federal environmental regulations.

Electrical Troubleshooting

Electrical troubleshooting

Item	Description	Action
Control operates pump in one direction only.	Control coil failure	<ul style="list-style-type: none"> Measure resistance at coil pins. Resistance should be 14.20 Ω (24V) or 3.66 Ω (12V) at 20°C [70°F]. Replace coil.
No pump function	No power to controller	Restore power to controller.
Erratic pump function	Electrical connection to pump is bad.	Disconnect connection, check wires, reconnect wires.
Filter bypass indicator switch	Filter switch may be bad.	<ul style="list-style-type: none"> Check/replace filter switch. Add gauge to filter bypass port to verify proper fluid flow and verify switch operation by measuring resistance. <ul style="list-style-type: none"> Open resistance \geq 510 Ω Closed resistance \leq 122 Ω

[Use a manual override to check proper pump operation and verify electrical problem, if available.](#)

Troubleshooting

Neutral Difficult or Impossible to Find

Item	Description	Action
Input to pump control	Input to control module is operating improperly	Disconnect input and check to see if pump comes back to neutral. <ul style="list-style-type: none"> • If Yes – input fault, replace or repair external controller • If No – go to next step
Neutral	Neutral set improper	Shunt servo gauge ports (M4 and M5) together with external hose and see if pump comes back to neutral. <ul style="list-style-type: none"> • If Yes – Control neutral improperly set (see Control Neutral Adjustment on page 43). • If neutral is still impossible to set, balance the swashplate (see Mechanical Neutral Adjustment on page 45). • If you still cannot set neutral, replace the control.

Transmission Operates Normally in One Direction Only

Item	Description	Action
Input to pump control.	Input to control module is operating improperly.	Check control input and repair or replace as necessary.
Control orifices	Control orifice(s) are blocked.	Clean control orifices.
Control screens	Control screen(s) are blocked.	Replace control screens. Only a Danfoss Authorized Service Center may remove the unit's endcap without voiding the warranty.
Exchange system pressure limiters	Exchanging the pressure limiter valves will show if the problem is related to the valve function.	If the problem changes direction, replace the valve that does not operate correctly.
Exchange high pressure relief valves	Exchanging the high pressure relief valves will show if the problem is related to the valve function.	If the problem changes direction, replace the valve that does not operate correctly.
Servo pressure low or decaying	Damaged servo seals may prevent servo piston from stroking the pump.	Check for torn/missing servo seals. Replace and retest. Only a Danfoss Authorized Service Center may remove the servo piston without voiding the warranty.
Bypass function open	Open bypass will cause one or both directions to be inoperative.	Close bypass function.

System Operating Hot

Item	Description	Action
Oil level in reservoir	Insufficient hydraulic fluid will not meet cooling demands of system.	Fill reservoir to proper level.
Heat exchanger	Heat exchanger is not sufficiently cooling the system.	<ul style="list-style-type: none"> • Check air flow and input air temperature for heat exchanger • Clean, repair or replace heat exchanger
Charge pressure	Low charge pressure will overwork system.	<ul style="list-style-type: none"> • Measure charge pressure. • Inspect and adjust or replace charge relief valve. • Inspect charge pump; repair or replace charge pump.
Charge pump inlet vacuum	High inlet vacuum will overwork system. A dirty filter will increase the inlet vacuum. Inadequate line size will restrict flow.	<ul style="list-style-type: none"> • Check charge inlet vacuum. If high, inspect inlet filter and replace as necessary • Check for adequate line size, length or other restrictions
System relief pressure settings	If the system relief valves are worn, contaminated, or valve settings are too low, the relief valves will be overworked.	Verify settings of pressure limiters and high pressure relief valves and adjust or replace valves as necessary.
System pressure	Frequent or long term operation over system relief setting will create heat in system.	Measure system pressure. If pressure is too high, reduce loads.

Troubleshooting

System Will Not Operate in Either Direction

Item	Description	Action
Oil level in reservoir.	Insufficient hydraulic fluid to supply system loop.	Fill reservoir to proper level.
Pump control orifices	Control orifices are blocked.	Clean control orifices.
Pump control screens	Control screens are blocked.	Replace control screens. Only a Danfoss Authorized Service Center may remove the unit's endcap without voiding the warranty.
Bypass function open	If bypass function is open, the system loop will be depressurized.	Close bypass valves. Replace high pressure relief valve if defective.
Low charge pressure with pump in neutral	Low charge pressure insufficient to recharge system loop.	Measure charge pressure with the pump in neutral. If pressure is low, go to Pump charge relief valve.
Low charge pressure with pump in stroke	Low charge pressure resulting from elevated loop leakage. Insufficient control pressure to hold pump in stroke.	Deadhead the pump to isolate it from the motor. With pump in partial stroke and engaged for only a few seconds, check pump charge pressure. Low charge pressure indicates a malfunctioning pump. Continue to next step. Good charge pressure indicates a malfunctioning motor or other system component. Check motor charge relief operation (if present).
Pump charge relief valve	A pump charge relief valve that is leaky, contaminated, or set too low will depressurize the system.	Adjust or replace pump charge relief valve as necessary.
Charge pump inlet filter	A clogged filter will under supply system loop.	Inspect filter and replace if necessary.
Charge pump	A malfunctioning charge pump will provide insufficient charge flow.	Repair or replace the charge pump.
System pressure	Low system pressure does not provide enough power to move load.	Measure system pressure. Continue to next step.
High pressure relief or pressure limiter valves	Defective high pressure relief or pressure limiter valves cause system pressure to be low.	Repair or replace high pressure relief or pressure limiter valves.
Input to control	Input operating improperly	Repair/replace control.

System Noise or Vibration

Item	Description	Action
Reservoir oil level	Low oil level leads to cavitation.	Fill reservoir.
Aeration of the oil/pump inlet vacuum	Air in system decreases efficiency of units and controls. Excessive noise, foaming oil, and hot oil all indicate air in system.	Find location where air is entering into the system and repair. Check that inlet line is not restricted and is proper size.
Cold oil	If oil is cold, it may be too viscous for proper function and pump cavitates.	Allow the oil to warm up to its normal operating temperature with engine at idle speed.
Pump inlet vacuum	High inlet vacuum causes noise/cavitation.	Check that inlet line is not restricted and is of proper size. Check filter and bypass switch.
Shaft couplings	A loose shaft coupling will cause excessive noise.	Replace loose shaft coupling..
Shaft alignment	Misaligned shafts create noise.	Align shafts.
Charge/system relief valves	Unusual noise may indicate sticking valves and possible contamination.	Clean/replace valves and test pump.

Sluggish System Response

Item	Description	Action
Oil level in reservoir	Low oil level causes sluggish response.	Fill reservoir.
High pressure relief valves/pressure limiter settings	Incorrect pressure settings affects system reaction time.	Adjust or replace high pressure relief valves.

Troubleshooting

Item	Description	Action
Low prime mover speed	Low engine speed reduces system performance.	Adjust engine speed.
Charge pressure	Incorrect pressure affects system performance.	Measure and adjust charge pressure relief or replace charge pump.
Air in system	Air in system produces sluggish system response.	Fill tank to proper level. Cycle system slowly for several minutes to remove air from system.
Contaminated control orifices	Control orifices are plugged.	Clean control orifices.
Contaminated control screens	EDC supply screen is plugged.	Replace control screens. Only a Danfoss Authorized Service Center may remove the unit's endcap without voiding the warranty.
Pump inlet vacuum	Inlet vacuum is too high resulting in reduced system pressure.	Measure charge inlet vacuum. Inspect line for proper sizing. Replace filter. Confirm proper bypass operation.

Adjustments

This section offers instruction on inspection and adjustment of pump components. Read through the entire topic before beginning a service activity.

Refer to [Pressure Measurements](#) on page 30 for location of gauge ports and suggested gauge size.

Standard Procedures

1. Ensure the surrounding area is clean and free of contaminants like dirt and grime.
2. With the prime mover off, thoroughly clean the outside of the pump.
3. Tag each hydraulic line, if removing the pump.
4. When you disconnect hydraulic lines, cap them and plug each open port to prevent contamination.
5. Inspect the system for contamination.
6. Check the hydraulic fluid for signs of contamination: oil discoloration, foam in the oil, sludge, or metal particles.
7. If there are signs of contamination in the hydraulic fluid, replace all filters and drain the hydraulic system.
8. Flush the lines and refill the reservoir with the correct filtered hydraulic fluid.
9. Before re-installing the pump, test for leaks.

Manufacturer's Warranty

Contamination can damage internal components and void the manufacturer's warranty.
Take precautions to ensure system cleanliness when removing and installing system lines.

Adjustments

Charge Pressure Relief Valve Adjustments

Operate the system with the pump in neutral (zero displacement), when measuring charge pressure.

This procedure explains how to check and adjust the charge pressure relief valve.

Charge Pressure Adjustment

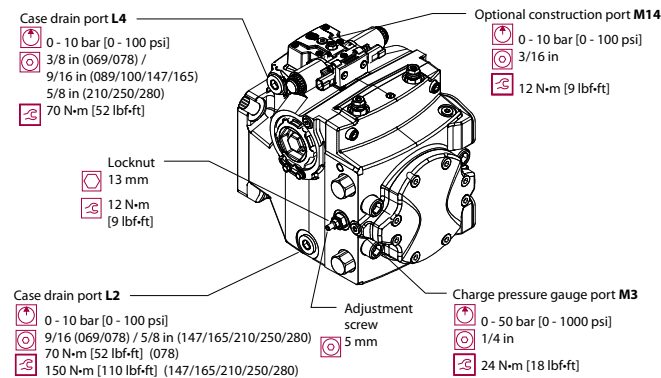

1. Install a 50 bar [1000 psi] pressure gauge in charge pressure gauge port M3.
2. Install a 10 bar [100 psi] gauge at case drain port L2 or L4.

The table below shows the acceptable actual pump charge pressure range for some nominal CPRV settings (refer to model code located on serial number plate).

Charge Pressure Range according to model code

Code	20	24	26	30
Actual charge pressure, bar [psi]	20 ± 1.5 [290 ± 21.8]	24 ± 1.5 [348 ± 21.8]	26 ± 1.5 [377 ± 21.8]	30 ± 1.5 [435 ± 21.8]

The factory set pressures at 1800 min⁻¹ (rpm) pump speed and a reservoir temperature of 50°C [120°F], and are referenced to case pressure. At higher pump speeds with higher charge flows the charge pressure will rise over the rated setting. Depending on the pressure rating, the charge pressure relief valve may have one or two springs.

3. Loosen the locknut and turn the adjusting screw clockwise to increase the setting, and counterclockwise to decrease it.

The approximate adjustment per turn

Number of springs	Change per turn
1 Spring	consult factory
2 Springs	3.9 bar [56.6 psi]

4. Torque locknut to 12 N•m [9 lbf•ft], while holding the adjusting screw.
5. Remove the gauges and plug the ports, when the desired charge pressure setting is achieved.

Adjustments

Pressure Limiter Adjustment

Warning

Pumps with only HPRV valves no longer contain pressure limiter screens and retainers. To convert such pumps to those with pressure limiter valves, please contact your Danfoss service partner.

H1P Base Models with pressure setting option B include PL screens and retainers.

Lock motor output shaft to adjust the pressure limiter setting. Lock the vehicle's brakes or rigidly fix the work function so it cannot rotate.

Pressure limiter adjustment

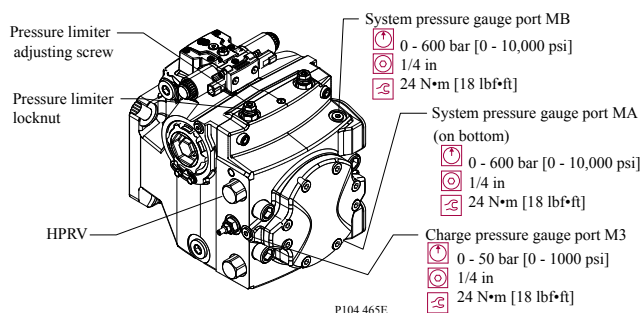

Endcaps are different for clockwise and counter clockwise rotation.

Clockwise and counter clockwise rotation

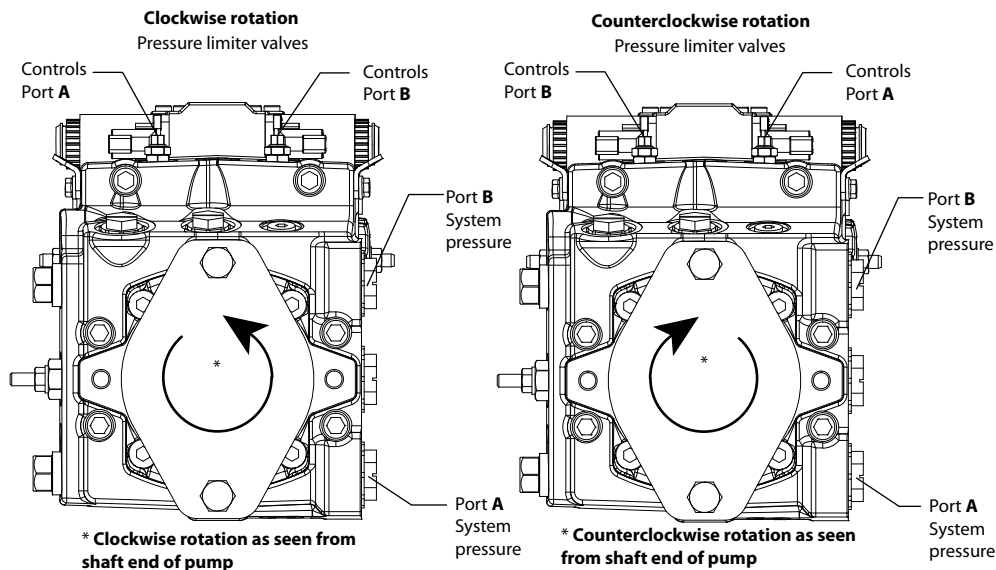

If you change pressure limiter settings, you must also change the HPRV valve to maintain proper PL function. Refer to table below for corresponding settings.

Pressure limiter setting (bar)

PL setting	150	180	200	230	250	280	300	330	350	380	400	430	460
											410	440	470
											420	450	480
HPRV setting	200	230	250	280	300	330	350	380	400	420	450	480	510

Adjustments

1. Install 600 bar [10 000 psi] pressure gauges in the high pressure gauge ports (MA and MB).
 2. Install a 50 bar [1000 psi] pressure gauge in the charge pressure gauge port (M3).
- Ensure charge pressure is properly set before checking pressure limiter.
3. Start the prime mover and operate at normal speed.
 4. Use a 14 mm wrench to loosen the locking nut (L024).
 5. Activate the control input until pressure in the high side of the system loop stops rising. This pressure is the PL setting.
 6. Return the pump to neutral and adjust the PL setting using a 6 mm internal hex wrench .
 7. Turn the adjusting screw clockwise to increase the PL setting, counter clockwise to decrease it.

The adjustment is very sensitive. Change per turn is 90 bar [1305 psi].

The model code on the serial plate gives the factory setting of the PL (Pressure Limiter). The PL setting is referenced to charge pressure. Subtract charge pressure from system pressure gauge readings to compute the effective PL setting.

The model code on the serial plate gives the factory setting of the PL (Pressure Limiter). The PL setting is referenced to charge pressure. Subtract charge pressure from system pressure gauge readings to compute the effective PL setting.

8. Repeat steps 4. and 5. until you reach the desired PL setting.
9. After adjustment, torque the lock nut (L024) to 20 N·m [15 lbf·ft].

! Caution

Do not over torque.

10. Shut down the prime mover.
11. Remove gauges and replace plugs.

Engaging the Bypass Function

It is possible to damage the drive motor(s) by operating in bypass mode without charge pressure. Move the vehicle/machine at a speed not more than 20% of maximum for a duration not exceeding 3 minutes.

Use this procedure to bypass the pump to allow moving the vehicle/machine short distances when you cannot start the prime mover.

Engaging the Bypass Function

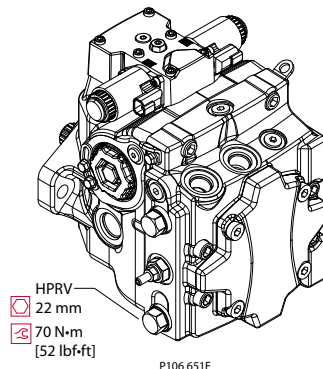

Adjustments

1. To open the HPRVs (L150), rotate three revolutions counterclockwise using a hex wrench.

! Caution

Do not rotate more than 3 revolutions, leakage will result.

2. Rotate them clockwise until seated to close the HPRVs.

See the following table for torque values:

HPRV Wrench Size and Torque Value

Frame size	Wrench size	Torque
045—100	22 mm	70 N•m [52 lbf•ft]

If machine is towable with HPRVs opened three turns and if wheels are locked (not towable) with HPRV valves closed, bypass function is working correctly.

Adjustments

Displacement Limiter Adjustment for Single Pumps

If your pump has displacement limiters, you will find them on either servo cover. You can limit forward and reverse displacement independently.

Displacement limiters are not pre-set by the factory. We install them as far as possible without contacting the servo piston. Limiting displacement requires clockwise adjustment of the limiting screw.

! Caution

Before adjusting the displacement limiter, mark the position of the servo cylinder. Be sure the servo cylinder does not turn when setting the displacement limiter locknut.

Displacement Limiter Adjustment

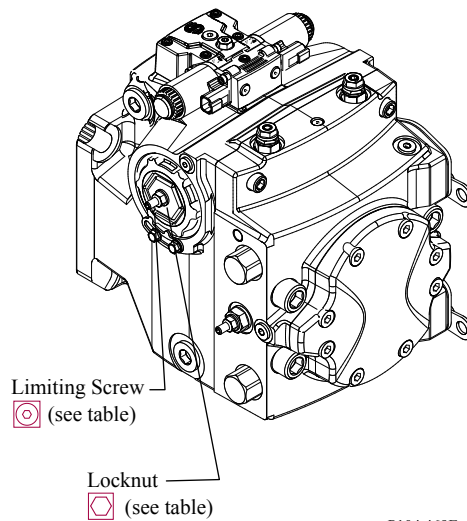

1. Loosen the locknut.
2. Rotate the adjusting screw to achieve the desired maximum displacement.
3. Set the adjusting screw against the servo piston by feel before counting turns.
Refer to the table for change per turn. Clockwise rotation decreases displacement, counterclockwise rotation increases it. Adjustment is possible from zero to maximum.

Approximate displacement change cm^3 [in^3] per revolution

045	053	060	068
5.1 [0.31]	6.0 [0.37]	6.8 [0.41]	7.7 [0.47]

4. After establishing the desired maximum displacement setting, hold the adjusting screw while torquing the locknut to the value in the table below.

Displacement Limiter Adjustment Data

Frame	045/053	060/068
Locknut wrench size, torque	13 mm, 24 N·m [18 lb·ft]	
Adjusting screw wrench size	4 mm	

5. Test operation of the vehicle/machine to verify proper maximum speed of vehicle/work function.

Adjustments

Control Neutral Adjustment

All functions of the Electric Displacement Control (EDC), are preset at the factory. If necessary, adjust the pump to neutral with the pump running on a test stand or on the vehicle/machine with the prime mover operating. If adjustment fails to give satisfactory results, you may need to replace the control or coils. See Minor repair for details.

Control neutral adjustment

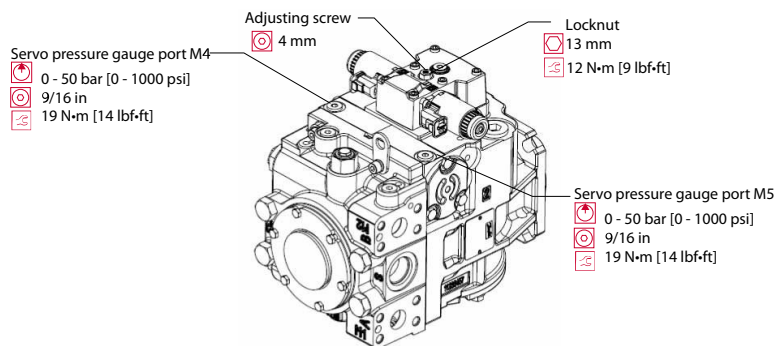

P106 343E

1. Install a 50 bar [1000 psi] gauge in each of the two servo gauge ports (M4 and M5).
2. Disconnect the external control input (electrical connections) from the control.
3. Start the prime mover and operate at normal speed.
4. Use a 4 mm internal hex wrench to hold the neutral adjusting screw (D015) stationary while loosening the locknut (D060) with a 13 mm wrench.
5. Observe pressure gauges and if necessary, turn adjusting screw (D015) to reduce pressure differential.

Adjustment of the EDC is very sensitive. Be sure to hold the hex wrench steady while loosening the locknut. Total adjustment is less than 120 degrees.

Neutral Adjustment (EDC) (bottom view)

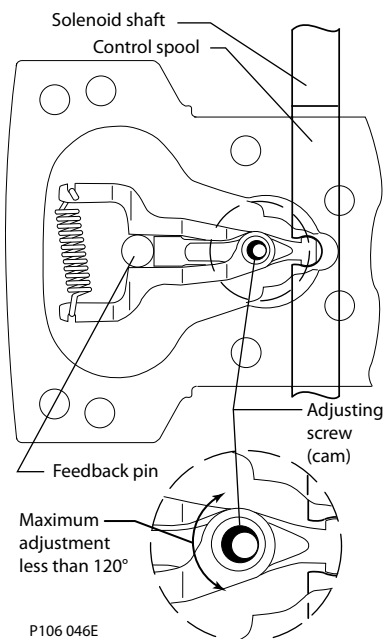

P106 046E

Illustration shows how cam on adjusting pin rotates to adjust for neutral position after pump is re-installed.

Adjustments

6. Rotate the neutral adjusting screw clockwise until the pressure increases on the gauge.

Note the angular position of the wrench.

7. Rotate the neutral adjusting screw counterclockwise until the pressure increases by an equal amount on the other gauge.

Note the angular position of the wrench.

8. Rotate the neutral adjusting screw clockwise half the distance between the wrench positions noted above.

The gauges should read the same pressure, indicating that the control is in its neutral position.

9. Hold the neutral adjusting screw stationary and tighten the locknut (D060). Torque to 10 N·m [9 lbf·ft].

 **Caution**

Do not over torque.

10. When the neutral position is set, stop the prime mover and remove the gauges.

11. Install the gauge port plugs.

12. Reconnect the external control input.

A small pressure differential of 1.5 bar [22 psi] or less is acceptable. Zero differential is usually not possible.

Adjustments

Mechanical Neutral Adjustment

Mechanical neutral is set with the pump running at 1800 min⁻¹(rpm). To set neutral, you must stroke the pump in each direction. The procedure is the same for each side of each pump for both the front and rear sections.

You can do this with a small movement of the eccentric screw on EDC controls, however non-feedback controls (NFPE/FNR) lack this mechanism. To stroke a pump with non-feedback control, you must provide a 100 Hz PWM signal to the control solenoids. If you perform this adjustment with the pump installed in a vehicle or machine, safely elevate the wheels or disconnect the mechanism to allow safe operation during adjustment.

This procedure details setting neutral for the entire pump, one side at a time. Alternate M4/M5 and MA/MB to zero out forward and reverse directions of the front unit, then move the gauges to M4/M5 of the rear unit and MC/MD (system gauge ports for the rear unit). Refer to the drawing on the next page to identify all ports. The front and rear sections are basically mirror images of each other. The control solenoids C1 and C2 are marked on each control.

While performing this adjustment, you monitor the following pressures:

- Servo pressure at M4 and M5
- System pressure at MA and MB
- Pressure differential between M4 and M5 (optional)
- Pressure differential between A and B (optional)

Unintended machine movement

Unintended movement of the machine or mechanism may cause injury to the technician or bystanders. Secure the machine or disable/disconnect the mechanism while servicing to protect against unintended movement.

Adjustments

Pump Setup

The figure below shows the locations of system and gauge ports you use when adjusting the servo neutral position.

System Pressure Gauge Ports

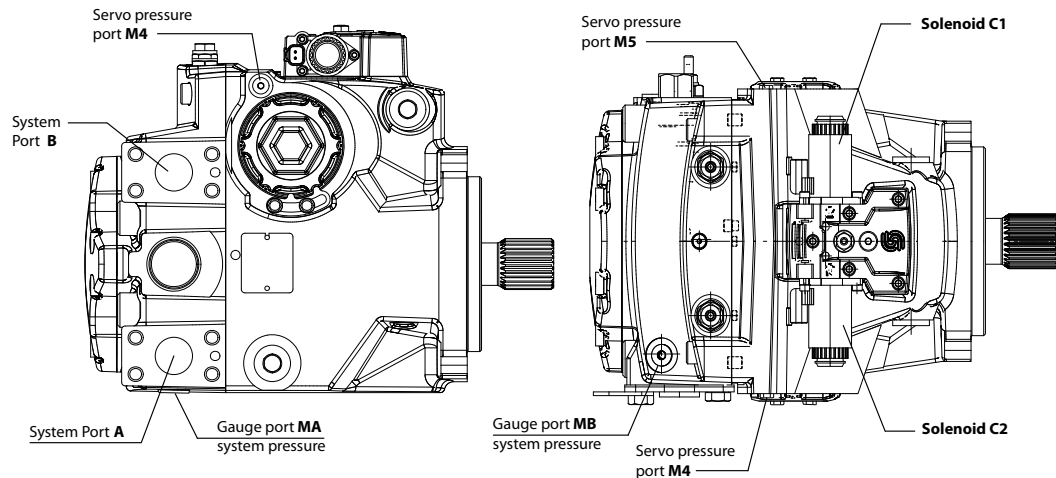

P106 489E

For more information see [H1P Ports Information](#) on page 30.

1. Attach a 50 bar [1000 psi] gauge to each servo pressure port M4 and M5.
2. Attach a 600 bar [10 000 psi] gauge to each system pressure port (MA and MB).
3. Remove servo cylinder locking screws (E350) and plates (E300) from both sides of the pump.
4. Disconnect the control solenoids from the vehicle wiring harness.
5. If using a PWM signal to set mechanical neutral, connect the control solenoids C1 and C2 to the signal source.

Ensure the source supplies no current to the solenoids until required in the following procedure.

Adjustments

Servo Adjustment

Servo Adjustment

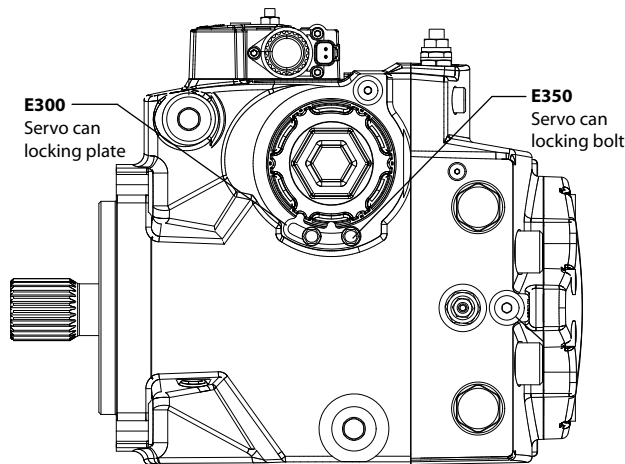

P106 490E

E300 Servo cylinder clamp

E350 Servo cylinder clamp bolt

1. Run prime mover at 1800 min⁻¹ (rpm).
2. If using a PWM signal, ensure the signal is off.
3. Check the servo pressure gauges, ensure the differential between M4 and M5 is less than 2.5 bar [36 psi].
4. Using a 3/4 in deep socket, unthread both servo cylinders 2-3 turns.

This step ensures the servo cylinders have no contact with the servo piston.

5. Stroke the pump by turning the control eccentric screw (or supplying current to solenoid C1) until the servo pressure at port M4 is 1 to 2 bar [14– 29 psi] greater than at port M5 and the system pressure gauges indicate displacement.

Pressure should be greater at port MA for clockwise rotation, or MB for counterclockwise rotation. This also indicates the servo piston is in contact with the servo cylinder on side M5.

6. Maintain servo pressure differential between 1-2 bar [14-29 psi] during this step. Slowly thread the servo cylinder on the M5 side in until the system pressure differential starts to decrease. Continue turning the servo cylinder in until the system delta pressure results in no machine movement.

System delta pressure (ports MA to MB or MC to MD) between 3-4 bar typically does not cause machine movement. If service of a pump is not performed on the machine, validation of machine movement must be checked upon machine start up.

7. Repeat steps 1. to 5. but stroke the pump in the opposite direction by turning the eccentric screw in the opposite direction, or by supplying current to solenoid C2 to complete setting neutral.

Reverse gauge locations (M4 for M5, MB for MA etc.) from those stated above since the pump is now stroking the other direction.

8. Set neutral for the rear pump by repeating steps **1. to 6.** on the rear pump. Remember that the rear pump is a mirror image of the front pump and therefore the locations of the servo gauge ports (M4/M5) and the control solenoids (C1/C2) are opposite.
9. Remove all gauges and replace gauge port plugs.

You can find wrench sizes and plug torques in the [Plug Size and Torque Chart](#) on page 69.

Minor Repair**Standard Procedures at Removing Pump**

Before working on the pump, thoroughly clean the outside. If the pump has an auxiliary pump attached, remove both pumps as a single unit.

1. With the prime mover off, thoroughly clean all dirt and grime from the outside of the pump.
2. Tag, disconnect, and cap each hydraulic line connected to the pump.
3. As hydraulic lines are disconnected, plug each open port, to ensure that dirt and contamination do not get into the pump.

Be careful, do not damage solenoids and electrical connections when using straps or chains to support the pump.

4. Ensure the work surface and surrounding area are clean and free of contaminants such as dirt and grime.
5. Inspect the system for contamination.
6. Look at the hydraulic fluid for signs of system contamination, oil discoloration, foam in the oil, sludge, or metal particles.
7. Before replacing the pump, replace all filters and drain the hydraulic system.
8. Flush the system lines and fill the reservoir with the correct, filtered hydraulic fluid.
9. Fill the pump with clean, filtered hydraulic fluid.
10. Attach the pump to the prime mover and torque mounting screws according to the manufacturers recommendation.
11. Replace all hydraulic lines.
12. Ensure the charge inlet line is filled with fluid.

Minor Repair

EDC/HDC Control Repair

EDC control module and solenoid removal/installation

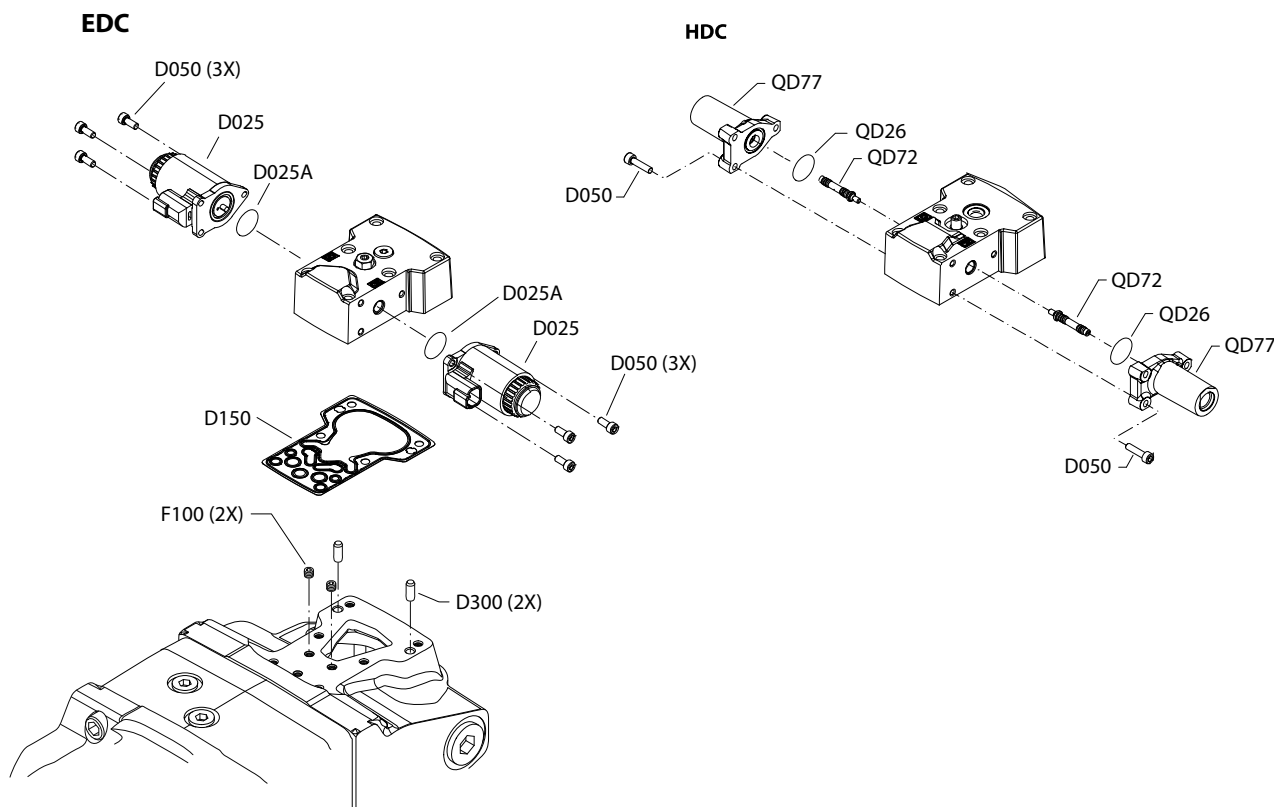

1. Using a 5 mm internal hex wrench, remove the six cap screws (D250)
2. Remove the control module and gasket (D150) and discard the gasket.
3. If necessary, remove orifices (F100) using a 3 mm internal hex wrench.

Tag and number the orifices for reinstallation.

4. If screen (D084) is clogged, use a hook to remove retaining ring (D098) and screen.
5. Remove and discard screen (D084).

Minor Repair

EDC/HDC Control Installation

Inspect the machined surfaces on the control and top of the pump. If you find any nicks or scratches, replace the component.

Ensure you install dowel pins (D300) in housing before installing control.

1. Install a new gasket (D150).
2. If you removed screen (D084), install a new one with the mesh facing outward.

Remove plug on top of control to ensure the swashplate feedback pin is properly positioned in the center of the control module when installing control.

Proper screen orientation

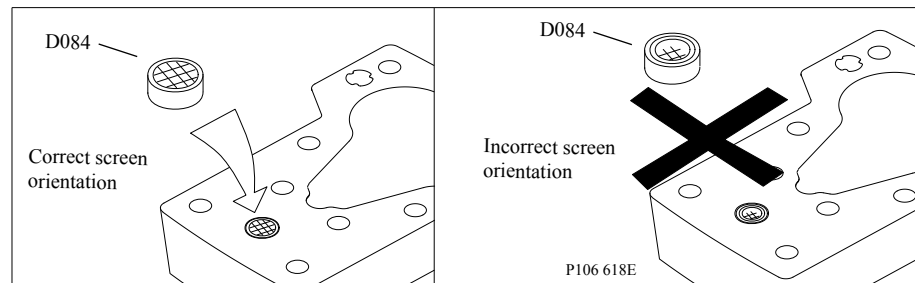

3. If previously removed, install orifices using a 3 mm internal hex wrench and torque to 2.5 N•m [1.8 lbf•ft].
4. Install the control module and six cap screws (D250).
5. Using a 5 mm internal hex wrench, torque the cap screws (D250) to 13.3 N•m [9.8 lbf•ft].

Torque sequence

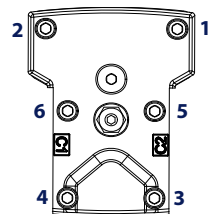

Control Solenoids Repair

1. Disconnect electrical connection and remove the three cap screws (D050) using a 4 mm internal hex wrench.
2. Remove the solenoid (D025) and O-ring (D025A). Discard the O-ring.
3. If necessary, remove the coil using a 12 point 26 mm socket.

Inspect the machined surfaces on the control and top of the pump. If you find any nicks or scratches, replace the component.

4. Lubricate new O-ring (D025A) using petroleum jelly and install.
5. Install solenoid with three cap screws (D050) using a 4 mm internal hex wrench and torque screws to 5 N•m [4 lbf•ft].
6. Install coil using a 12 point 27 mm socket and torque coil nut to 5 N•m [3.7 lbf•ft].
7. Reconnect electrical connections and test the pump for proper operation.

Minor Repair

MDC Control Repair

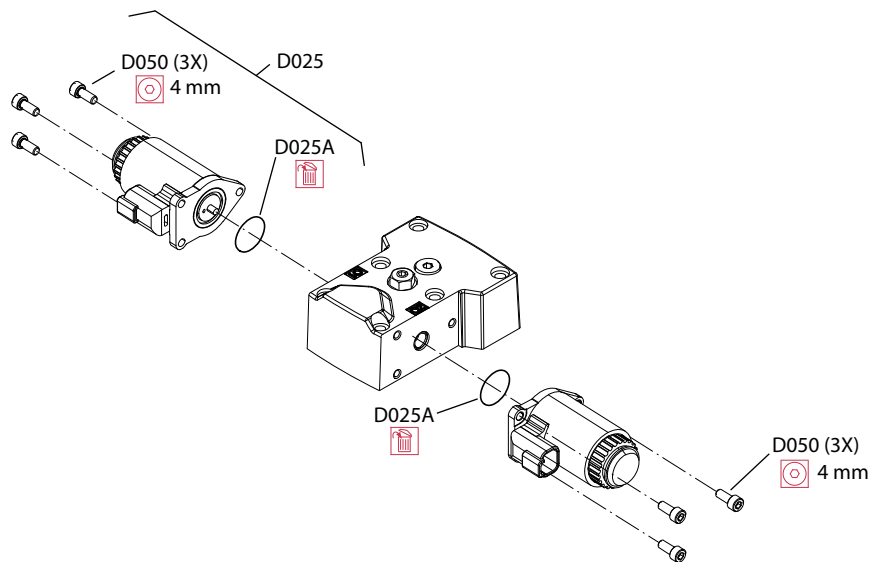

MDC Repair Legend:

- D80** – Solenoid
- D81** – O-ring
- D098** – Retaining ring
- D750** – Neutral start switch
- D751** – O-ring

Wrench size and torque

Item	Description	Wrench size	Torque
D065	O-ring plug	3/16 internal hex	12 N•m [9 lbf•ft]
D200	Feedback pin	13 mm deep well socket	22.5-27.5 N•m [16.6-20.3 lbf•ft]
D250	Cap screw	5 mm internal hex	13.3 N•m [9.8 lbf•ft]
D735	Plug	3/4 inch	30 N•m [22 lbf•ft]
F00A, F00B	Servo orifice	3 mm internal hex	2.5 N•m [1.8 lbf•ft]
F00P	Supply orifice		
F00T	Tank orifice		

1. Using a 5 mm internal hex wrench, remove the six cap screws (D250)
2. Remove the control module and gasket (D150) and discard the gasket.
3. If necessary, remove servo orifices (F00A, F00B), supply orifice (F00P), and tank orifices (F00T) using a 3 mm internal hex wrench.

Tag and number the orifices for reinstallation.

4. If screen (D084) is clogged, use a hook to remove retaining ring (D098) and screen.
5. Remove and discard screen (D084).
6. Before removing the control, note the position of the control lever for reassembly.

The functionality of the MDC control and the neutral position of the pump can be lost. Do not disassemble the MDC control.

Minor Repair

MDC Control Assembly

Ensure you install dowel pins (D300) in housing before installing control.

The pump will lose control, causing a potentially hazardous situation.

If a feedback pin comes off during operation, ensure the feedback pin is properly torqued before continuing with reassembly.

1. Install a new gasket (D150).
2. If you removed screen (D084), install a new one with the mesh facing outward.
3. Install retaining ring (D098).

Proper screen orientation

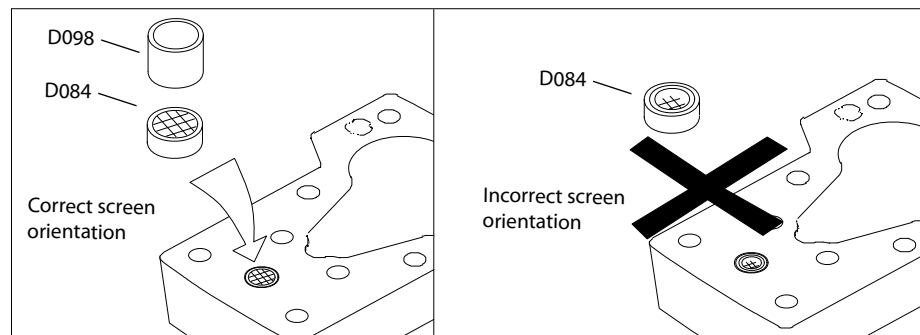

Remove plug on top of control to ensure the swashplate feedback pin is properly positioned in the center of the control module when installing control.

4. If previously removed, install orifices using a 3 mm internal hex wrench and torque to 2.5 N•m [1.8 lbf•ft].
5. Install the control module and six cap screws (D250).
6. Using a 5 mm internal hex wrench, torque the cap screws (D250) to 13.3 N•m [9.8 lbf•ft].

Torque sequence

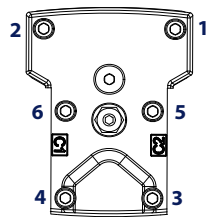

Minor Repair

Angle sensor on EDC Repair

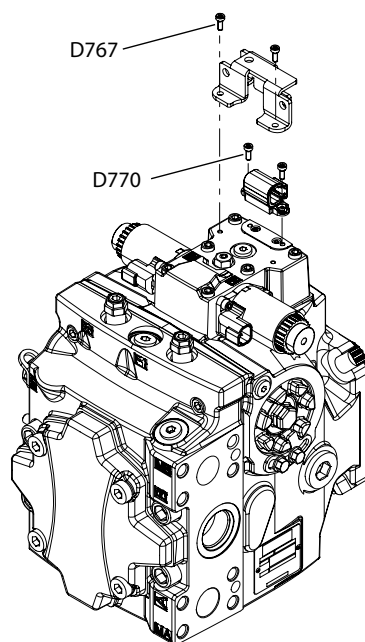

1. Clean the exterior of the pump to remove debris.
2. Remove protection cover screws (D767) using a 4 mm internal hex wrench.
3. Remove the protection cover from the control.
4. Discard the protection cover if it is damaged.
5. Remove sensor screws (D770) using a 4 mm internal hex wrench.
6. Remove and discard the sensor.
7. Position a new sensor on control housing.
8. Using a 4 mm internal hex wrench, fasten sensor to control housing with screws (D770). Torque screws to 1.85 N·m [1.36 lbf·ft].
9. Position protection cover on control housing over sensor.
10. Using a 4 mm internal hex wrench, fasten protection cover with screws (D767). Torque screws to 1.85 N·m [1.36 lbf·ft].

⚠ Warning

Calibration of sensor output in vehicle software is mandatory after sensor replacement because output signal can vary from one sensor to the other.

Minor Repair

EDC with Angle Sensor Repair

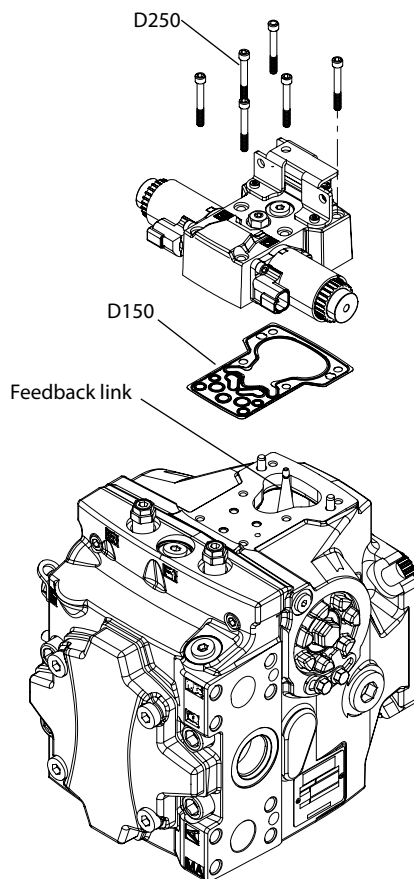

Dowel pins (D300) must remain in the housing.

1. Clean pump externally with clean solvent to remove debris.
2. Using a 5 mm internal hex wrench, remove the six cap screws (D250)
3. Remove the control module and gasket (D150) and discard the gasket.
4. Install a new gasket (D150).
5. Ensure assembly fixture is positioned over the linkage spring in EDC center.
6. Position the control on the pump housing and ensure that feedback pin on swashplate is positioned properly in control arm.

Minor Repair

7. Pull assembly fixture out before installing control screws.

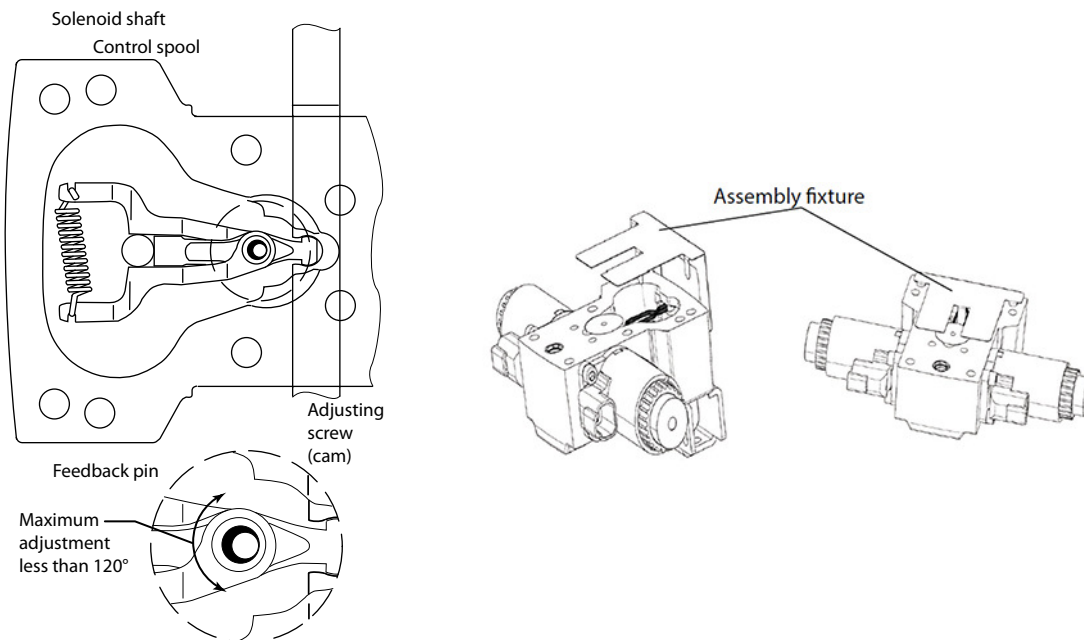

Remove plug (D065) and verify the swashplate feedback pin is properly positioned between control feedback arms.

- 8.** Install the control module and six cap screws (D250).
- 9.** Using a 5 mm internal hex wrench, fasten control to pump with screws (D250).
- 10.** Torque screws to 13.3 N·m [9.8 lbf·ft] following torque sequence shown.

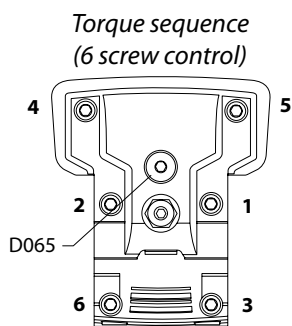

For proper neutral adjustment procedure, refer to *Control Neutral Adjustment* on page 43 topic.

⚠ Warning

Calibration of sensor output in vehicle software is mandatory after sensor replacement because output signal can vary from one sensor to the other.

Minor Repair

Automotive Control Repair

Drain pump completely before removing control.

Possible erratic pump operation.

Do not allow metal fragments to fall into control housing. Do not fail to install screen.

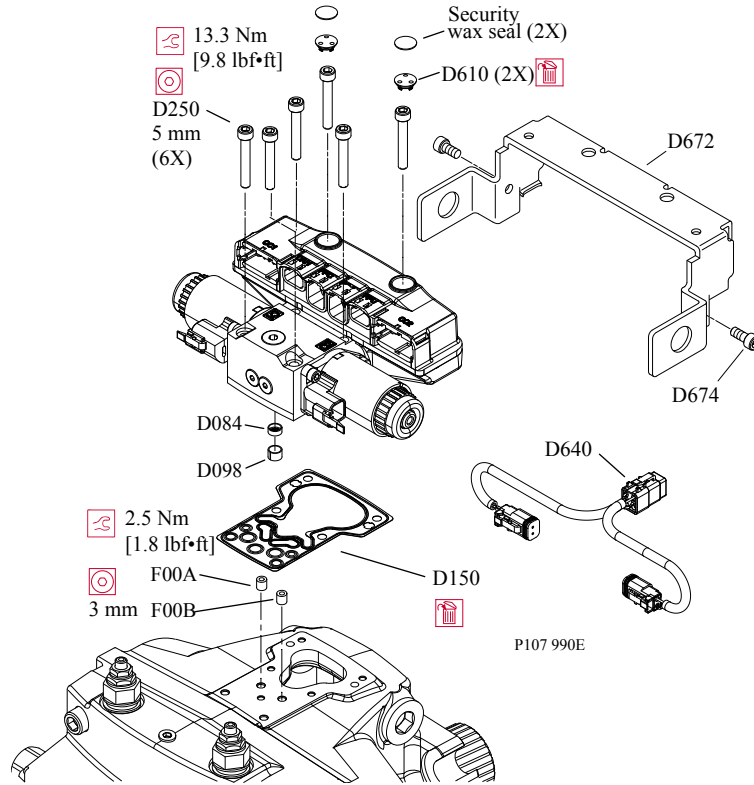

1. Disconnect and remove wiring (D640).
2. Fabricate a special tool to remove two plastic plugs (D610).
 See drawing below for tool dimensions.

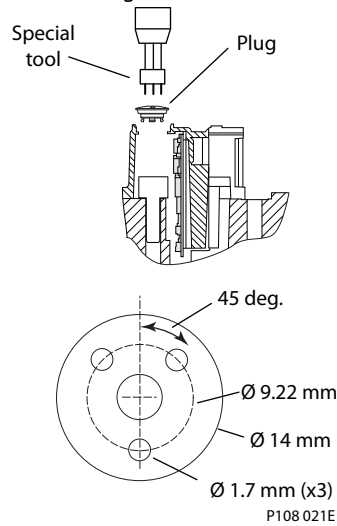

3. Push down on plug and turn 45 degrees counterclockwise.
4. Discard plugs.
 Wax seals will be destroyed when the plugs are removed.

Minor Repair

⚠ Caution

Do not damage the housing in the plug sealing area.

5. Use a 5 mm internal hex to remove two screws (D674) and remove shield (D672).
6. Use a 5 mm internal hex to remove six screws (D250) and remove control from pump.
7. Remove and discard gasket (D150).

Alignment pins are pressed into control. Do not remove them.

8. If necessary, remove orifices (F00A, F00B) using a 3 mm internal hex.

Tag and number the orifices for reinstallation.

9. If it is necessary to remove the screens, drill out screen retention ring (D098).

Drill Out Retention Ring

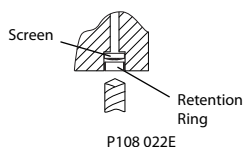

Note screen orientation for reassembly.

10. Remove and discard screen (D084).

Minor Repair

AC Control Installation

Inspect control, pump housing and plastic PC board housing, and its sealing areas.

! Caution

Do not damage the plastic housing in the plug sealing area when installing the screws.

Inspect the machined surfaces on the control and top of the pump. If you find any nicks or scratches, replace the component.

If pump has been rebuilt or a new control is being installed, control software must be recalibrated. Refer to H1 Automotive Control User Manual for recalibration instructions.

1. If you removed screen (D084), install a new one with the mesh facing outward.
2. Install a new retaining ring (D098).

Be sure screen will not move axially in bore after retention ring is installed.

Proper screen orientation

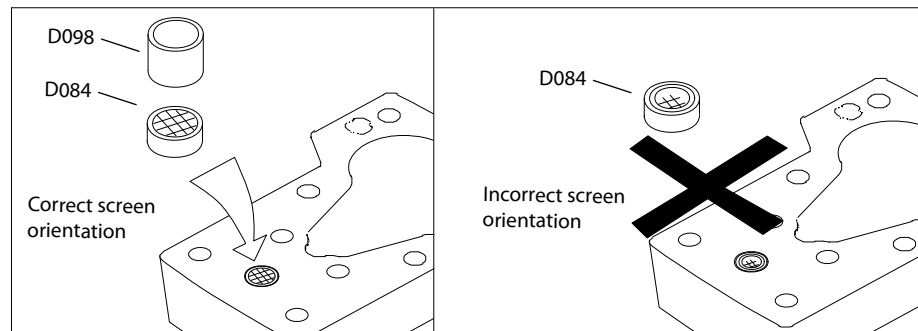

3. If previously removed, install orifices using a 3 mm internal hex wrench and torque to 2.5 N•m [1.8 lbf•ft].
4. Install a new gasket (D150).
5. Install the control module and six cap screws (D250).
6. Using a 5 mm internal hex wrench, torque the cap screws (D250) to 13.3 N•m [9.8 lbf•ft].

Torque sequence

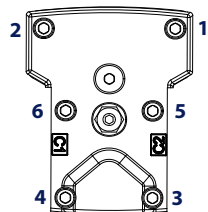

7. Connect wiring (D640).
8. Install new plastic plugs with O-rings (D610) using the special tool, press plugs in and turn 45 degrees clockwise.

If control will continue to be under warranty, install new sealing wax of a different color (original wax is blue). Pumps without sealing wax installed will not be warranted.

9. Install protection bracket (D672).
10. Install screws (D674). Torque to 5 N•m [3.7 lbf•ft].

Minor Repair

Shaft Seal, Roller Bearing and Shaft Repair

The shaft assembly is serviceable without disassembling the pump. Orient the pump on the work surface so the shaft is pointing to the side.

Shaft assembly

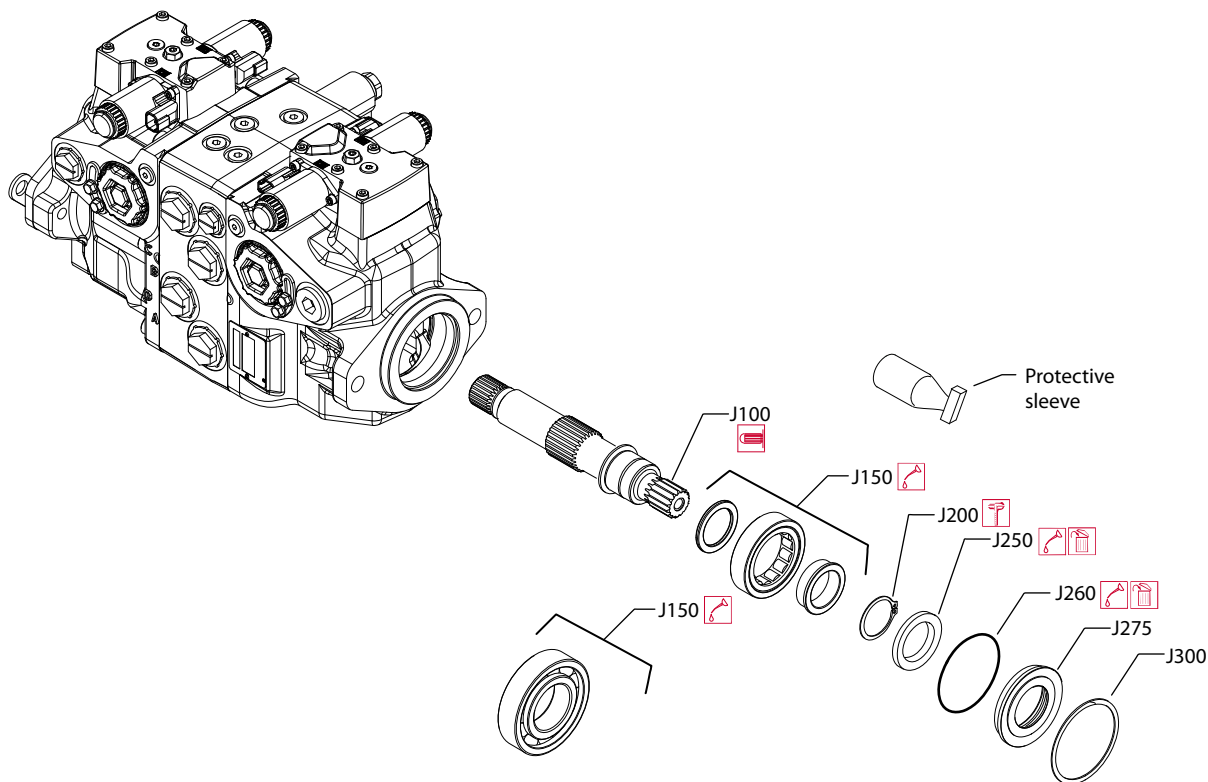

1. Unwind the spiral ring (J300) from the housing to release the shaft/seal/bearing subassembly.
2. Pry on the lip of the seal carrier (J275) to dislodge it from the pump.
3. Remove the seal carrier. Remove and discard O-ring (J260).
4. Press the seal (J250) out of the carrier and discard.
5. Pull the shaft (J100) with bearing (J150) out of the pump.
If necessary, tap lightly on the shaft to dislodge it from the cylinder block.

⚠ Caution

Do not damage the housing bore, shaft or bearing when removing the shaft and shaft seal.

6. Remove the retaining ring (J200) using retaining ring pliers.
Press the bearing off the shaft.
7. Inspect the shaft journals for wear, scratching, and pits.
8. Check the splines for fretting; replace if damaged.
9. Rotate the bearing, if it does not rotate smoothly, replace it.
10. Press the bearing (J150) onto the shaft (J100) and replace the retaining ring (J200).
11. Ensure the retaining ring diameter is less than 38.84 mm [1.53 in] when installed on the shaft.
12. Install the shaft/bearing assembly into the pump.
13. Lubricate and install a new O-ring (J260) onto seal carrier (J275).
14. Press a new seal (J250) into the seal carrier.

Minor Repair

15. Press the seal until it is flush within +0.12mm [0.005 in] or -0.72 mm [0.0028 in] of the inside lip of the carrier: *see illustration*.

Positioning seal in seal carrier

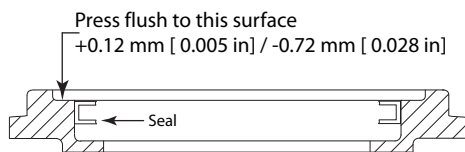

16. Cover the shaft with a protective sleeve while installing the seal carrier.
17. Hand press the seal carrier into the housing.
18. Ensure the seal carrier clears the spiral ring groove in the housing.
19. Remove the protective sleeve.
20. Wind the spiral ring into the housing.
21. Ensure the inside diameter of the spiral ring is greater than 68 mm [2.677 in] after installation.

Minor Repair

Charge Pump Repair

If an auxiliary pump is attached, remove auxiliary pump and coupling before servicing charge pump.

Position pump with front shaft pointing downward. Attach securely to a proper work stand.

If necessary, you must replace charge pump components (gearset, outer ring, valve and pressure balance plates) as a kit.

Charge pump removal/installation

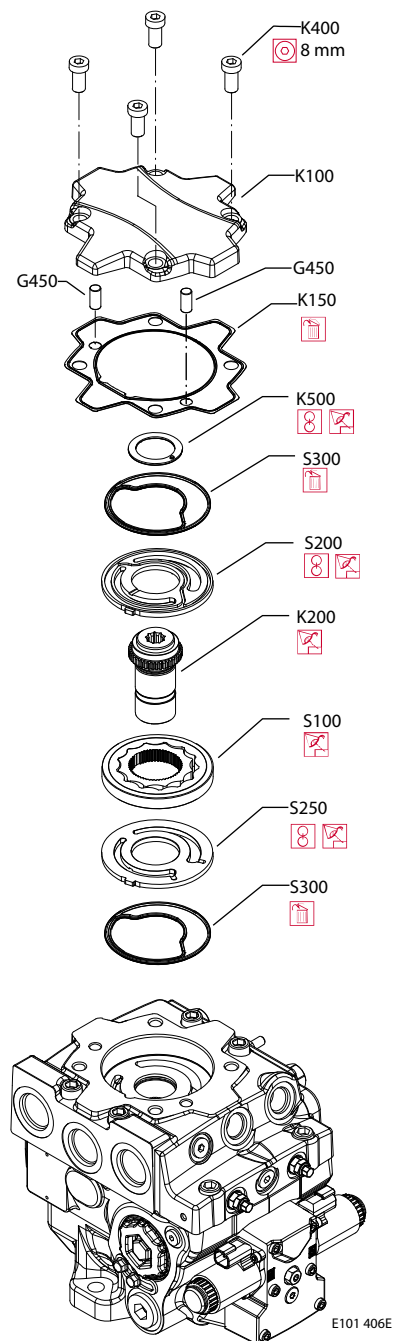

1. Remove end cover/auxiliary pad screws (K400) using a 8 mm internal hex wrench.

Alignment pins (G450) are in the end cover. They may dislodge during disassembly.

Minor Repair

2. Remove and discard gasket (K150).
3. Remove thrust washer (K500).
Note thrust washer orientation.
4. Use a small hook to remove pressure balance plate (S200) and seal (S300); discard seal.
Note plate orientation.
5. Remove coupling (K200). Use a small hook if necessary.
6. Remove the charge pump outer ring (S150), and gearset (S100).
7. Remove valve plate (S250) with seal (S300); discard seal.
8. Inspect the components for wear, scratches or pitting.
9. Carefully inspect the valve and pressure balance plates.
Scratches on these components will cause a loss of charge pressure. If any component shows signs of wear, scratching or pitting, replace it.
10. Install new seals (S300) in the valve (S250) and pressure balance (S200) plates.
11. Install valve plate (S250) in the same orientation as removed.
12. Lubricate and install charge pump (S100) and outer ring (S150).
13. Install charge pump coupling (K200).
14. Install pressure balance plate (S200) in the same orientation as removed.
15. Install the thrust washer (K500); coated side goes toward charge pump coupling (K200).
16. Install a new cover gasket. (K150).
17. If removed, install guide pins (K450).
18. Install the auxiliary pad or charge pump cover and cap screws.
19. Using a 8 mm internal hex wrench, torque the cap screws (K400) to 92 N·m [68 lbf·ft].

Torque sequence

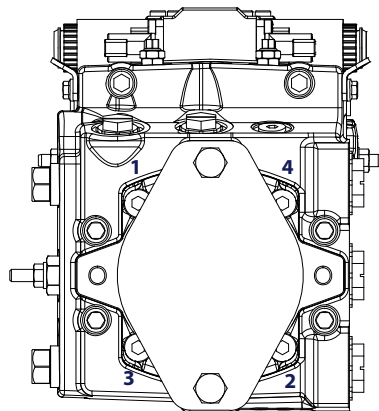

P106 346E

Ensure proper torque on aux pad screws (K400) and if necessary, replace screws.

20. Reinstall auxiliary pump or pad seal (K250) and shipping cover ((K300).

If necessary, remove auxiliary pump, or shipping cover (K300) and pad seal (K250) as shown below:

Minor Repair

Auxiliary pads

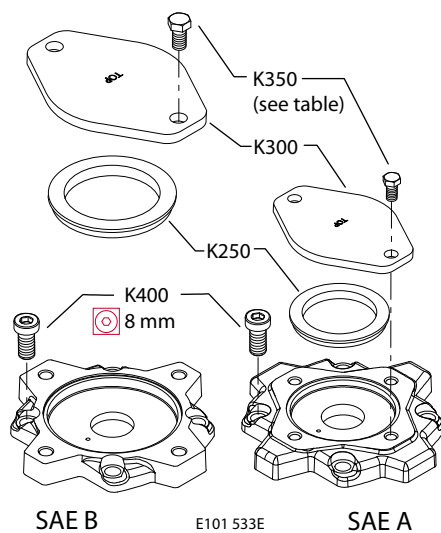

Cover Screw K350

Aux. Cover Pad	Cover Pad A	Cover Pad B
Wrench size and torque	17 mm 48 N·m [35 lbf·ft]	18 mm 77 N·m [58 lbf·ft]

Minor Repair

High Pressure Relief Valve Repair

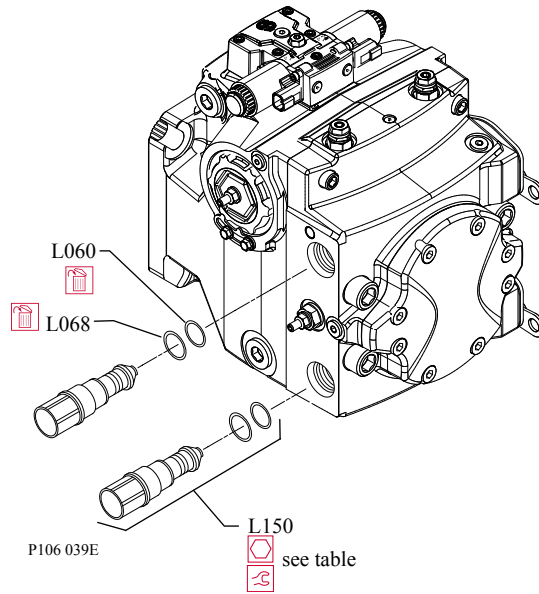

1. Using a hex wrench wrench shown in the table below, remove the HPRVs (L150).
2. Inspect the sealing surfaces in the pump for nicks or scratches, check the valves for damage.
3. Replace any damaged components.
4. Remove and discard the O-rings (L060) and backup rings (L068).
5. Lubricate and install new backup rings (L068) and O-rings (L060).
6. Install HPRVs, and torque to the value in the table.

Frame size	Wrench size	Torque
069/078/089/100	22 mm	70 N•m [52 lbf•ft]
115/130/147/165/210/250/280	30 mm	110 N•m [81 lbf•ft]

7. Operate the vehicle/machine through full range of controls to ensure proper operation.
8. Check for leaks.

Minor Repair

Charge Pressure Relief Valve Repair

! **Caution**

Replace the charge pressure relief valve (V010) as a complete unit. Do not attempt to repair the internal components of the valve.

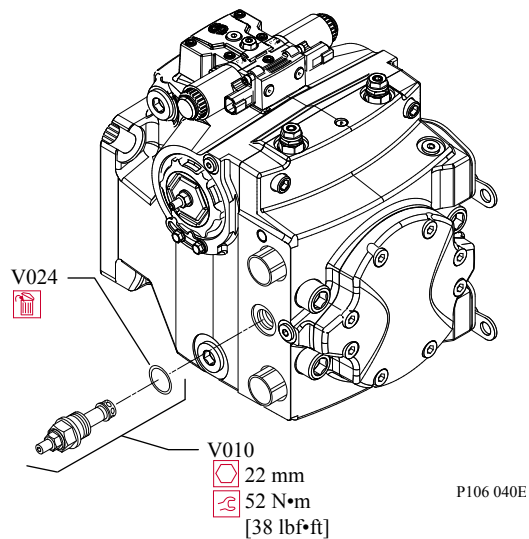

1. Using a 22 mm wrench, remove the charge pressure relief valve (V010).
 2. Discard a seal (V024).
 3. Inspect the sealing surfaces of the pump for nicks or scratches.
 4. Lubricate and install the new seal (V024).
 5. Install the charge pressure relief valve, and torque to 52 N·m [38 lbf·ft].
 6. Operate vehicle/machine through full range of controls to ensure proper operation.
- See for adjustment instructions.

Minor Repair

Pressure Limiter Repair

⚠ Warning

Pumps with only HPRV valves no longer contain pressure limiter screens and retainers. To convert such pumps to those with pressure limiter valves, please contact your Danfoss service partner.

H1P Base Models with pressure setting option B include PL screens and retainers.

⚠ Caution

Replace the pressure limiter valve (V010) as a complete unit. Do not attempt to repair the internal components of the valve.

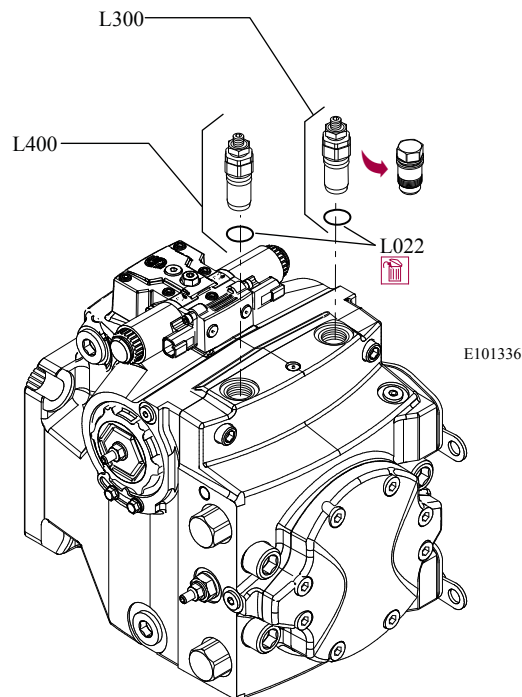

1. Using a 17 mm wrench, remove the pressure limiter valve (L100), and discard O-ring.
 2. Inspect the sealing surfaces of the pump for nicks or scratches.
 3. Install new O-ring.
O-ring is available separately.
 4. Lubricate O-ring with petroleum jelly.
 5. Replace pressure limiter valve and torque to 40 N-m [29 lbf-ft].
 6. Operate pump at full range of controls to ensure proper machine operation.
- See [Pressure Limiter Adjustment](#) on page 39 for adjustment instructions.

Torque Chart

Fasteners and Plugs

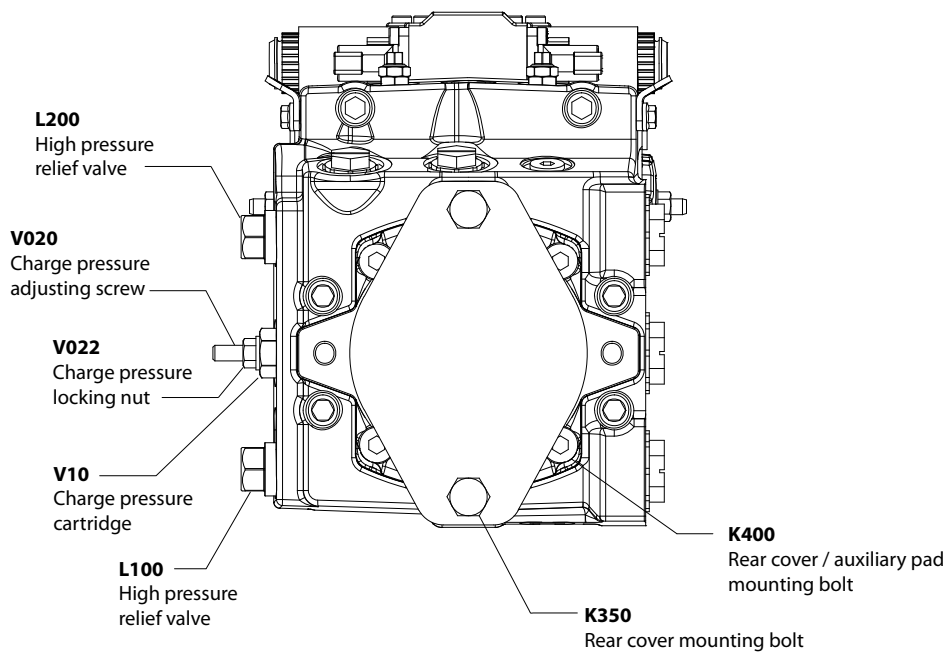

P106 348E

Torque Chart

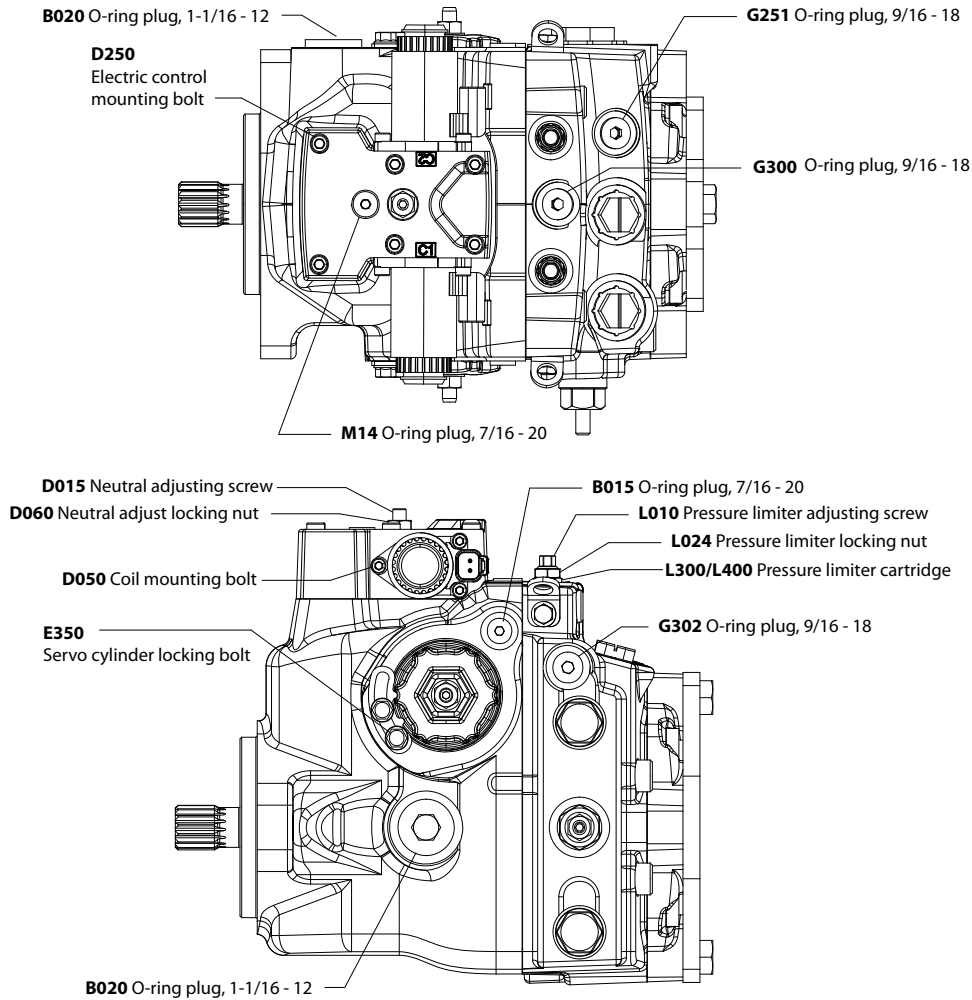

P106 349E

Torque Chart

Fastener Size and Torque Chart

H1P 045/053 and 060/068

Item	Fastener	Wrench size	Torque
D015	Neutral adjust screw	4 mm internal hex	NA
D050	Coil mounting bolt	4 mm internal hex	8 N•m [9 lbf•ft]
D060	Neutral adjust locking nut	13 mm	10 N•m [7 lbf•ft]
D250	Electric control mounting bolt	5 mm internal hex	13.3 N•m [9.8 lbf•ft]
E350	Servo cylinder locking bolt	11 mm	14.5 N•m [11 lbf•ft]
K350 A pad	Shipping cover mounting bolt	17 mm	8.7 N•m [6.4 lbf•ft]
K350 B pad	Shipping cover mounting bolt	18 mm	12 N•m [8.9 lbf•ft]
K400	Rear cover/aux pad mounting bolt	8 mm internal hex	92 N•m [68 lbf•ft]
L010	Pressure limiter adjust screw	6 mm	NA
L300 L400	Pressure limiter cartridge	17 mm	40 N•m [29 lbf•ft]
L024	Pressure limiter locking nut	14 mm	20 N•m [15 lbf•ft]
L100 L200	High pressure relief valve	22 mm	70 N•m [52 lbf•ft]
V10	Charge pressure cartridge	22 mm	52 N•m [38 lbf•ft]
V020	Charge pressure adjusting screw	4 mm internal hex	NA
V022	Charge pressure locking nut	13 mm	12 N•m [9 lbf•ft]

Plug Size and Torque Chart

Item	O-ring plug	Wrench size	Torque
B015	7/16–20	3/16 in internal hex	19 N•m [14 lbf•ft]
B020	1-1/16–12	9/16 in internal hex	49 N•m [36 lbf•ft]
D065	7/16–20	3/16 in internal hex	19 N•m [14 lbf•ft]
G250	9/16–18	7 mm internal hex	22–26 N•m [16–20 lbf•ft]
G300 G302	9/16–18 UNF	1/4 in internal hex	42 N•m [30 lbf•ft]

Products we offer:

- Cartridge valves
- DCV directional control valves
- Electric converters
- Electric machines
- Electric motors
- Gear motors
- Gear pumps
- Hydraulic integrated circuits (HICs)
- Hydrostatic motors
- Hydrostatic pumps
- Orbital motors
- PLUS+1® controllers
- PLUS+1® displays
- PLUS+1® joysticks and pedals
- PLUS+1® operator interfaces
- PLUS+1® sensors
- PLUS+1® software
- PLUS+1® software services, support and training
- Position controls and sensors
- PVG proportional valves
- Steering components and systems
- Telematics

Danfoss Power Solutions is a global manufacturer and supplier of high-quality hydraulic and electric components. We specialize in providing state-of-the-art technology and solutions that excel in the harsh operating conditions of the mobile off-highway market as well as the marine sector. Building on our extensive applications expertise, we work closely with you to ensure exceptional performance for a broad range of applications. We help you and other customers around the world speed up system development, reduce costs and bring vehicles and vessels to market faster.

Danfoss Power Solutions – your strongest partner in mobile hydraulics and mobile electrification.

Go to www.danfoss.com for further product information.

We offer you expert worldwide support for ensuring the best possible solutions for outstanding performance. And with an extensive network of Global Service Partners, we also provide you with comprehensive global service for all of our components.

Local address:

Hydro-Gear

www.hydro-gear.com

Daikin-Sauer-Danfoss

www.daikin-sauer-danfoss.com

**Danfoss
Power Solutions (US) Company**
2800 East 13th Street
Ames, IA 50010, USA
Phone: +1 515 239 6000

**Danfoss
Power Solutions GmbH & Co. OHG**
Krokamp 35
D-24539 Neumünster, Germany
Phone: +49 4321 871 0

**Danfoss
Power Solutions ApS**
Nordborgvej 81
DK-6430 Nordborg, Denmark
Phone: +45 7488 2222

**Danfoss
Power Solutions Trading
(Shanghai) Co., Ltd.**
Building #22, No. 1000 Jin Hai Rd
Jin Qiao, Pudong New District
Shanghai, China 201206
Phone: +86 21 2080 6201

Danfoss can accept no responsibility for possible errors in catalogues, brochures and other printed material. Danfoss reserves the right to alter its products without notice. This also applies to products already on order provided that such alterations can be made without subsequent changes being necessary in specifications already agreed. All trademarks in this material are property of the respective companies. Danfoss and the Danfoss logotype are trademarks of Danfoss A/S. All rights reserved.