

Operation guide

PAHT C pumps

PAHT C 2- 6.3

Installation, Operation and Maintenance Manual



Table of Contents	Contents	
	Table of Contents	2
	Validity	4
1.	Introduction	5
1.1	General	5
1.2	Symbols	5
1.3	Manufacturer and customer service address:	6
1.4	Country specific information	6
1.4.1	Uited Kingdom	6
2.	Safety	6
2.1	General information	6
2.2	Preferred system design	6
2.3	Commissioning and servicing the unit	7
2.4	Adhere to the following important points	7
2.5	In case of doubt	7
3.	Technical data	7
3.1	Approved applications and operational limits for the pumps	7
3.2	Application range	7
3.3	Electric motor data	7
3.4	Noise and vibration	7
3.5	Dimension drawings	7
3.6	Space requirement	7
3.7	Filtration	8
3.8	Properties of water	8
3.9	Air bubbles	8
3.10	Chemicals	8
4.	Arrival inspection, transportation, handling, lifting and storage	8
4.1	Arrival inspection	8
4.2	Warning	8
4.3	General safety information	8
4.4	Transport and handling	8
4.5	Return to supplier	9
4.6	Storage	9
5.	Installation and commissioning	10
5.1	Important dimensions	10
5.2	Cleanliness	10
5.3	Fluid temperature	10
5.4	Electrical data	10
5.5	Local regulations	10
5.6	Pre mounting checklist, based on Danfoss preferred system designs	11
5.7	Lifting and positioning	11
5.8	Mount the different equipment	11
5.9	Electrics	11
5.10	Instrumentation	11
5.11	Connections	11
5.12	Ensure free flow	12
5.13	Verify setting of safety/relief valves	12
5.14	Bleed and remove air from the pump	12
5.15	Verify direction of rotation	12
5.16	Commissioning	12
5.16.1	Open system	12
5.16.2	Closed system	12
5.17	Check the filter condition	12
5.18	Instruct operator and maintenance personnel	12
6.	Operation of motor pump unit	13
6.1	General safety information	13
6.2	What to listen and look for	13

7.	Maintenance and service of the pump unit	13
7.1	General safety information	13
7.2	Service and inspection interval for the pump	13
7.3	Shut down of the system	13
7.4	Disassembling and assembling the pump unit	14
7.5	Assembling the pump unit	14
7.6	Procedure for mounting the pump back onto electric motor	14
7.7	Getting the pump unit back into operation	14
7.8	Storage of the pump	14
8.	Troubleshooting and scrapping criteria	15
8.1	General safety information	15
8.2	Operational conditions which can cause pump failures	15
8.3	Mechanical failure	15
8.4	Electrical failure	15
8.5	Responsibility	15
8.6	Scrapping criteria	15
	Appendices for Installation, Operation and Maintenance Manual	17
	Table of Contents	18
1.	Data sheet PAHT C 2-6.3 pumps (A!234386502982en000401)	19
2.	Pump instruction PAHT C 2-6.3pumps (AN234386502875en-000202)	31
3.	Electric motor manual (180R9230)	43
4.	Parts list PAHT C 2-6.3 (A!234386502982en000401)	49
5.	Trouble shooting guide for PAH / PAHT / PAHT C / PAHT G / PAHT 674 and PAH F pumps	57
6.	Right and wrong - Trouble shooting guide for water hydraulic systems (180R9042)	69

Operation guide | Installation, Operation and Maintenance Manual for PAHT C 2-6.3 pumps

Validity

This manual is valid for PAHT C pumps both non ATEX and ATEX certified versions. An ATEX certified pump is indicated by Ex in the designation - example PAHT C 2 Ex.

In case the pump delivered is ATEX certified, the additional ATEX instruction must also be read.

PAHT C 2	Code no.	180B1030	PAHT C 2 Ex	180B1130
	Serial no.	XXXXXX02-XXX		XXXXXX02-XXX
PAHT C 3.2	Code no.	180B1031	PAHT C 3.2 Ex	180B1131
	Serial no.	XXXXXX02-XXX		XXXXXX02-XXX
PAHT C 4	Code no.	180B1032	PAHT C 4 Ex	180B1132
	Serial no.	XXXXXX02-XXX		XXXXXX02-XXX
PAHT C 6.3	Code no.	180B1033	PAHT C 6.3 Ex	180B1133
	Serial no.	XXXXXX02-XXX		XXXXXX02-XXX

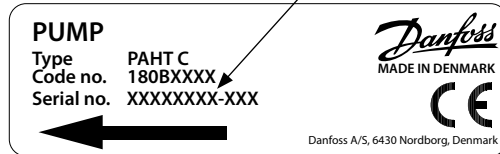

The serial number is referring to the Serial no. on the product label. The digits shown (02) indicate the version number of the pump. This documentation is compatible with previous pump versions.

1. Introduction

1.1 General

The PAHT C pumps and pump units are manufactured by Danfoss A/S, and are sold and marketed by a net of authorized distributors world wide.

This manual contains the necessary instructions for the installation, operation and service of the pumps used for technical water.

In case the pump delivered is ATEX certified, the additional ATEX instruction must also be read.

The PAHT C pumps must not be used for other purposes than those recommended and specified without first consulting your local pump distributor.

In the following text - Installation, Operation and Maintenance Manual, the PAHT C pumps will be called PAHT pumps.



Use of the pump in other applications not suitable for the pump unit can cause damages to the pump unit, with risk of personal injury.



All personnel being responsible for operation and maintenance of the pump unit must read and fully understand these instructions, especially the section "Safety", before:

- Transportation of the pump unit
- Lifting the unit
- Installing the pump unit
- Connecting the pump unit to the water system
- Connecting the electric motor and instrumentation
- Commissioning the unit
- Servicing the motor pump unit, mechanical and electrical parts
- Decommissioning the motor pump unit

The pump must always be installed and used in accordance with existing national/local sanitary, safety regulations and laws.

It is the responsibility of the safety officer or the chief operator to assure compliance with all local regulations that are not taken into account in this manual.



Changing the pumps' or pump units' operational limits and hardware:

- Changes to the delivered pump or motor pump system may only be done with a written approval from Danfoss High Pressure Pumps.

- Operation outside the Danfoss specifications requires a written approval from Danfoss High Pressure Pumps.
- If any changes are made without written approval the warranty will automatically become void.

It is important that these instructions are always available to the personnel concerned.

1.2 Symbols



Indicates something to be noted by the reader



Indicates a situation which will or could result in damage to the pump and its function



Indicates a situation which will or could result in personal injury and/or damage to the pump



Electrical hazard - Indicates a high-voltage warning



Safety glasses required



Hearing protection required



Safety shoes required



Safety helmet required



Protective garments must be worn

Protective garments must be worn



Danger Hot
Do not touch

Danger HOT.
Do not touch



Electrical hazard

Electrical hazard

1.3 Manufacturer and customer service address:

Danfoss A/S
High Pressure Pumps
 Nordborgvej 81,
 DK-6430 Nordborg
 Denmark

Telephone: +45 7488 2222
 Fax: +45 7445 3831
 Email: highpressurepumps@danfoss.com
 Web: hpp.danfoss.com

Your local Danfoss pump distributor can be found on our homepage.

1.4 Country specific information

1.4.1 United Kingdom

UK importer:

Danfoss Ltd.
 22 Wycombe End
 HP9 1NB Beaconsfield
 United Kingdom

2. Safety



2.1 General information

Dangers that can arise from not following the instructions:

When the pump or pump system is managed by untrained personnel, there is a danger of:

- Death or fatal injuries
- Costly damages and claims



Electrical hazard

All electrical installation work must only be carried out by authorized personnel in accordance with EN60204-1 and/or local regulations.

It is recommended to install a lockable circuit breaker to avoid inadvertent starting and/or electrical hazard. The lockable circuit breaker must be used during installation, operation and maintenance.

It is recommended to place a local safety switch nearby the pump, enabling service personnel to cut power for the electric motor.

Protect the motor and other electrical equipment from overloads with suitable equipment.

In case the pump delivered is ATEX certified, the additional ATEX instruction must also be read.



Protective garments must be worn



Always wear suitable safety clothing when handling the pump.

When working near the pump system, safety shoes, safety glasses, hearing protection and safety helmet must always be worn.



Danger Hot
 Do not touch

Under certain operational conditions the surface of the pump can be above 60°C / 140°F. Under these conditions the pump must be labelled with a "Danger Hot" sign.

When using an electric motor, the motor must always be supplied with adequate cooling ventilation.

When using an electric motor together with a VFD (Variable Frequency Drive), the motor must be designed for operation with VFD. VFD operation may increase the temperature inside the electric motor if the motor is not designed for VFD operation. This can damage the motor and cause unintended breakdown.



Before start-up, the settings for all protective devices, such as sensors/switches and safety valves must be verified and free flow from safety valves must be ensured.



All pipe and hose connections must be stress-free mounted, securely fastened to the pump and well supported. Improper installation will or could result in personal injury and/or damage to the pump.

Use of this manual does not relieve operation and maintenance personnel of the responsibility of applying good judgement when operating and maintaining the pump and its components.

2.2 Preferred system design

Danfoss recommends to build systems with a high degree of safety. Danfoss preferred system design and P&ID are found in appendix 1, Data sheet, and appendix 2, Instruction.



It is always the system builders' responsibility that the system design does not cause any kind of hazard and is adapted to local regulations and standards.

Proper installation, proper start up and shut-down devices as well as high-pressure protection equipment is essential.

2.3 Commissioning and servicing the unit

It is recommended that commissioning and servicing are carried out by a minimum of two people, where one is acting as a supervisor.

2.4 Adhere to the following important points

- Before using the pump/pump unit it is very important to read and understand this user manual.

- Do not try to lift the pump unit manually; most of the pumps weigh more than 20 kilos, see specific weight for the pump in the appendix 1, Data sheet.
- Always bleed the pump prior to initial start-up.
- Do not mount the pump without the bell housing and a flexible coupling.
- Do not try to start the unit before the system components are mounted, bled and adjusted.
- Flush the system thoroughly before connecting the pump or pump unit.
- Check rotation direction of the motor before mounting the pump.

2.5 In case of doubt

Please contact Danfoss A/S in case of doubt. Contact information are listed in section 1.3, Manufacturer and customer service address.

3. Technical data



3.1 Approved applications and operational limits for the pumps

The pump and the pump units are designed for the use in systems with technical water mixed with chemical or media other than water with low viscosity.

The PAHT C pumps must not be used for other purposes than those recommended and specified without first consulting your local pump distributor.



Use of the pump in other applications not suitable for the pump unit can cause damages to the pump unit, with risk of personal injury.

For system integration of the pumps, please see appendix 1, Data sheet and appendix 2, Instruction.

3.2 Application range

See appendix 1, Data sheet.

3.3 Electric motor data

See recommended motor in appendix 1, Data sheet or appendix 3, IOM for motors. The motors mentioned are the most common used motors by Danfoss High Pressure Pumps.

3.4 Noise and vibration

Noise level for a pump unit with a "standard" motor measured according to EN ISO 3744:2010, see appendix 1, Data sheet. Possibilities to reduce noise and vibration are described in the same Data sheet.

3.5 Dimension drawings

Dimensions of the different pumps can be found in appendix 1, Data sheet.

3.6 Space requirement

When doing service or replacing the complete pump unit, it is recommended to have sufficient space available around the pump in order to ensure easy access. Sufficient space means at least 1 meter/40 inches around the pump. When working with high pressures, it is important to have the right space available around the pump as stated in the safety requirements.



3.7 Filtration

(10µm absolute [$\beta_{10} \geq 5000$])

Requirements are specified in appendix 1, Data sheet and appendix 2, Instruction.

Danfoss recommends not to build a filter bypass function or use filters with an integrated bypass. If the above recommendation is not followed the warranty for the pump will automatically become void.

It should be possible to monitor the condition of the filter via the differential/delta pressure across the filter.

Using insufficient filtration or a filter bypass can cause a failure or decreased service life of the pump.

3.8 Properties of water

It is recommended NOT to use the pump for other media than specified in the Data sheet.



3.9 Air bubbles

Large bubbles in a pressurised system can result in damage to piping, equipment and the pump.

All air must be bled from both the low-pressure and high-pressure side before the system is pressurised. Special consideration should be given in order to minimize air bubbles in the feed flow. Air bubbles can cause cavitation.



3.10 Chemicals

The pumps should not be exposed to any chemicals that can result in damage to piping, equipment and internal parts of the pump.

4. Arrival inspection, transportation, handling, lifting and storage

4.1 Arrival inspection

The pump is packed in a cardboard or wood box with plugs in the port connections to protect the pump from damage during transportation.

When the shipment has arrived it is important to check the pump for any damages. The name plate/type designation must be in accordance with the delivery note and your order.

In case of damage and/or missing parts, a report should be documented and presented to the carrier at once.



4.2 Warning

Before any lifting operation is performed, environmental conditions must be taken into consideration (Ex-rated areas, wind speed, wet/dry conditions, lifting height, etc.).

4.3 General safety information

Personnel involved in lifting and transporting the equipment (see Safety, chapter 2) must be trained in handling and safety procedures when lifting heavy loads. Many of the pumps and pump units weigh more than 20 kilos, which requires lifting slings and suitable lifting devices; e.g. an overhead crane or industrial truck to be used as minimum.

4.4 Transport and handling

Small pumps which have a weight below 20 kilos (weight can be found in appendix 1, Data sheet) can be handled by hand if they are not mounted together with an electric motor. The weight of a small pump with a motor will be above 20 kilos.

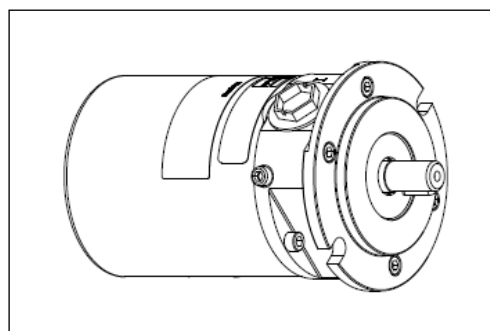
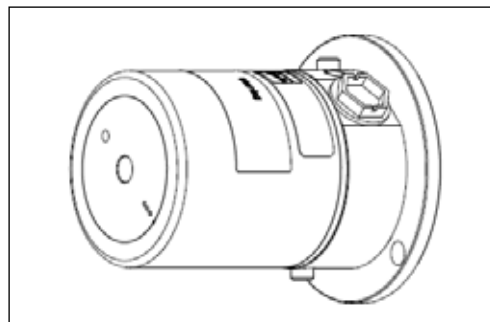

Pumps which have a weight above 20 kilos (see appendix 1, Data sheet) must be handled by using lifting eyes and slings.

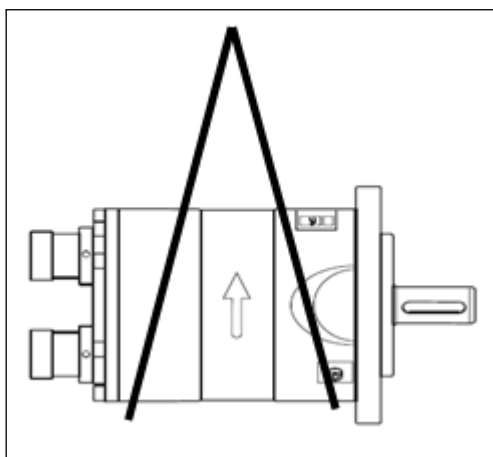
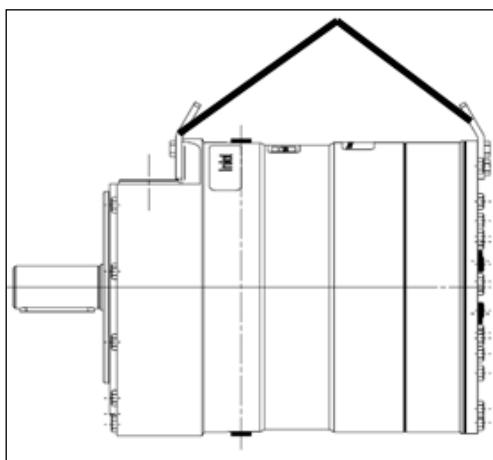

Never use only one sling and make sure the slings does not slip off the pump.

When the pump is mounted together with an electric motor, the pump unit always weigh more than 20 kilos and must be handled by using slings around the pump unit.

See below examples of where to/not to attach the lifting slings on the pump unit:

Correct lifting with 2 separate slings:

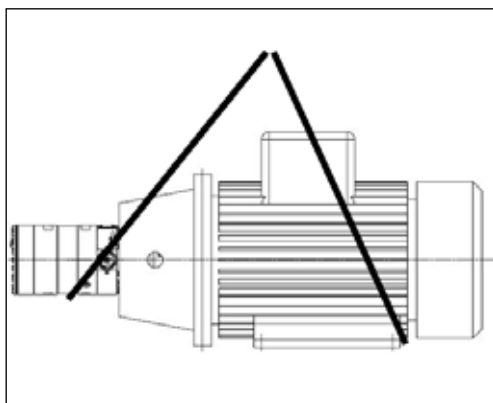

Wrong lifting:

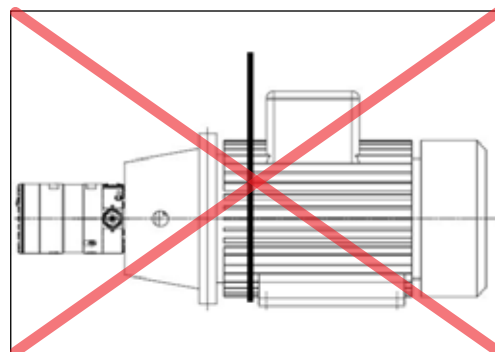
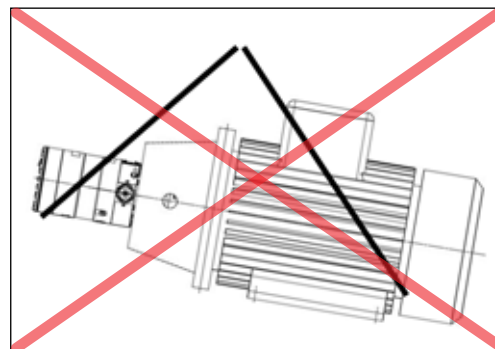

When lifting the pump unit, one sling must be attached to the electric motor and one sling around the pump.

Only some motors and pumps have specific lifting eyes.

**Do not use connections/nozzles for lifting!
Do not use only one sling!**

Make sure that the unit/load is balanced before lifting. The centre of the mass varies from pump/pump unit size to pump/pump unit.

How to mount the pump and the electric motor correctly, see appendix 1, Data sheet or appendix 2, Instruction.



Incorrect lifting can result in personal injury and/or damage to the pump unit, see appendix 2, Instruction.

4.5 Return to supplier

Please see maintenance chapter 7.

4.6 Storage

Each pump is tested before shipment, and will therefore contain water. For storage temperature and frost protection see appendix 2, Instruction.

The pumps are NOT delivered frost protected from the factory.

5. Installation and commissioning



5.1 Important dimensions
Physical dimensions and connections of the pump unit are described in appendix 1, Data sheet.



5.3 Fluid temperature
Before start-up, the fluid and pump housing temperature must be within the specified temperature range listed in appendix 1, Data sheet.



5.2 Cleanliness
It is very important that the tubes and pipes are **completely clean**: no dirt, chips or burrs are allowed.



5.4 Electrical data
Check voltage, current frequency and rated power on the electric motor and VFD settings on the name plate placed on both the motor and the VFD.

Flush all piping before connecting the high-pressure pump to ensure the system is clean. Internal surfaces of the piping must not be corroded. If dirt or rust is not removed, the pump and the valves can be damaged. In worst case the pump can be damaged beyond repair!



5.5 Local regulations
Commissioning must always be done in accordance with valid regulations and local standards.

Open system design

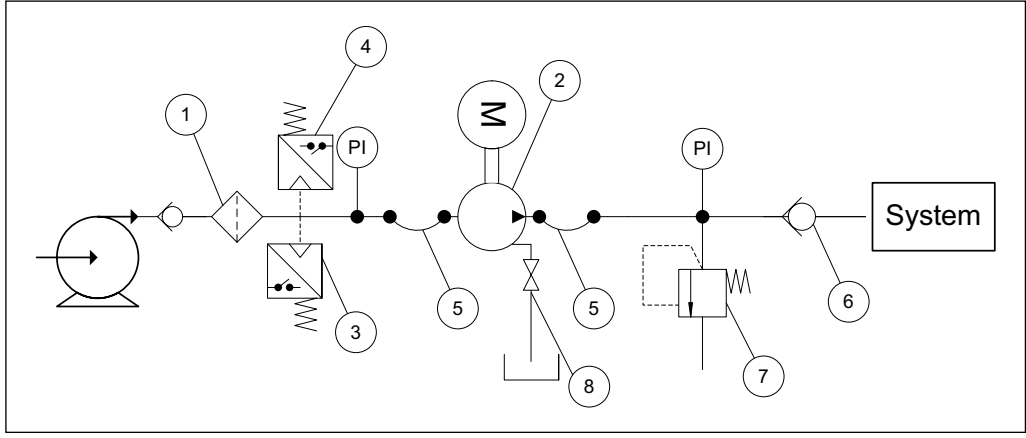

Closed system design

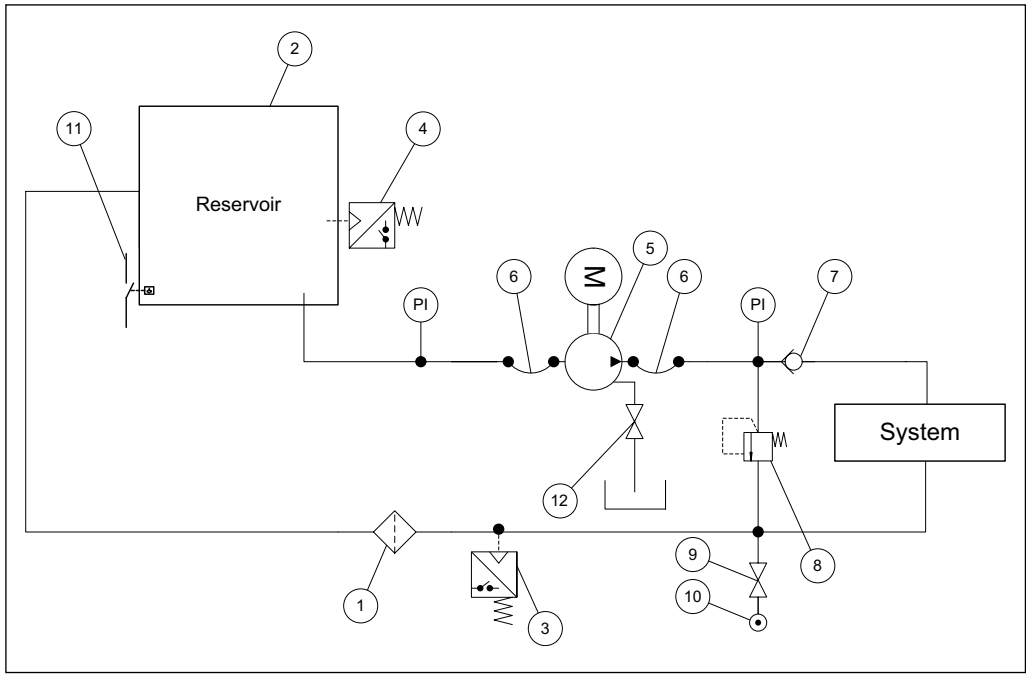

5.6 Pre mounting checklist, based on Danfoss preferred system designs

Table 1: Check points when assembling and commissioning system

	Check points	Comment	OK ?
CP1	Ensure that the environmental conditions are safe.	See Arrival inspection, transportation, handling, lifting and storage, chapter 4.	
CP2	Minimum and maximum start-up temperature for fluid and pump.	See Data sheet or Instruction, appendices 1 and 2.	
CP3	Filtration condition (10µm absolute ($\beta_{10} \geq 5000$))	See Danfoss requirements in Data sheet and Instruction, appendices 1 and 2	
CP4	Power supply for electric motor and VFD.	See Data sheet for the used motor and VFD.	
CP5	Safety circuit / breaker must be sized for the motor and environment (corrosion and humidity)	See Data sheet for the used safety circuit.	
CP6	Bolts and screws must conform to environmental conditions as well as fluid and torque requirements.		
CP7	Instrumentation, pressure switch should be designed to conform to the environment (corrosion and humidity).	See Data sheet for the used equipment.	
CP8	Check the factory settings of the safety/relief valves or pressure relief valves (1).	See Data sheets for the used valves.	
CP9	Check the settings of the pressure transmitter/switch (2) set at min. inlet pressure.	See Data sheet or Instruction, appendices 1 and 2.	
CP10	Check that all pressure indicators (PI) are selected to be able to measure the system pressure range.	Scaling should at least be 1 barg or more precise.	
CP11	Check coupling distance (air gab – movement of the spider)	3 – 5 mm	
CP12	Check correct connections on the pump (in & outlet)		
CP13	Check piping for possible air gaps.		



5.7 Lifting and positioning

Lift the pump unit onto base (Remember vibration dampers, if needed). Fasten the motor to the base.

See also chapter 4, Arrival inspection, transportation, handling, lifting and storage.

5.8 Mount the different equipment

(connections, pipes, tubes, check and safety/relief valves, etc.)

- The hard piping and flexible hoses used must be of proper design and must be installed in accordance with the manufacturer's recommendations.
- Misalignment of the hard pipes may give unintended stress on the pump port connection and may damage the pump.
- Prevent excessive external pipe load.
- Do not connect piping by applying external force (use of wrenches, crane, etc.) Piping must be aligned without residual stress.
- Do not mount expansion joints so that their force applies internal pressure on the pump connections.

5.9 Electrics

All electrical installation work must be carried out by authorized personnel in accordance with EN60204-1 and/or local regulations. (see also Safety, chapter 2)

Turn off the safety circuit breaker and lock it.

Mount the power cable on the electric motor.

If a VFD is used, adjust the protective motor switch/VFD to the current limits found on name plate of the electric motor.

5.10 Instrumentation

The pressure switch/sensor should be mounted as close to the pump as possible. It is recommended to test the pressure/sensor switch via an instrumentation manifold.

Mount the pressure switch/sensors according to the manufacturer's instructions.

5.11 Connections

Mount and tighten connections and check valve(s) as specified.

5.12 Ensure free flow

Ensure free flow from relief valve (table 1, item 5.6, CP 8). A blocked relief valve can cause excessive build-up of pressure and thereby cause dangerous situations and damage to the whole system.

5.13 Verify setting of safety/relief valves

Make sure, the relief valve is placed correctly (see open system design, item 1).

Check the pressure settings on the name plate of the relief valve. If they are within specifications, you can continue.

5.14 Bleed and remove air from the pump

Open bleeding plugs. Keep the plugs open until the high-pressure pump is bled.

If the pump is submerged, remove all bleeding plugs before mounting in reservoir.

5.15 Verify direction of rotation

The direction of rotation must always follow the arrow. The arrow is placed on the pump or pump unit.

Check the direction of rotation before mounting the pump.

Unlock the safety circuit breaker. Start the motor for 1 second and observe the direction of rotation either looking on the fan of the motor or on the coupling through the hole in the bell housing (not available on all bell housings). If the motor is turning the wrong direction, switch two phases in the connection box of the motor or reprogram the direction in VFD.

When the motor is turning in the right direction, the pump can be mounted.

5.16 Commissioning

5.16.1 Open system

- Check if filter element is present and mounted correctly.
- Switch on the circuit breaker for both motor(s) and VFD(s).
- Check rotation of the feed pump.
- Start feed pump.
- Bleed high-pressure pump until only water leaves the high-pressure pump. Remember to close all bleeding and draining plugs.
- Adjust pressure relief valve to minimum setting.
- Check rotation of the high-pressure pump by description in 5.15.
- Start high-pressure pump for 2 minutes, to make sure all air is out of the system.
- Adjust pressure relief valve to working pressure.
- Check all fittings for leakage.

- Check the temperature switch/controls. The high-pressure pump must stop if temperature is above specified set point.
- Check the pressure switch/controls. The high-pressure pump must stop if pressure is below specified set point.
- If the system is running within the system design limits, the system is released for operation.

5.16.2 Closed system

- Check if the reservoir is clean.
- Check if filter element is present and mounted correctly.
- Fill water at the reservoir using the filling valve. Inspect immediately for leakage.
- Bleed high-pressure pump until only water leaves the high-pressure pump. Remember to close all bleeding and draining plugs.
- Adjust pressure relief valve to minimum setting.
- Check rotation of the high-pressure pump by description in 5.15.
- Start high-pressure pump for 2 minutes, to make sure all air is out of the system.
- Check reservoir low level switch/controls. The high-pressure pump must stop if low level switch is activated.
- Adjust pressure relief valve to working pressure.
- Check the temperature switch/controls. The high-pressure pump must stop if temperature is above specified set point.
- Check the filter pressure switch/controls. A warning must be given if pressure is above specified set point.
- If the system is running within the system design limits, the system is released for operation.



5.17 Check the filter condition

Evaluate contamination found in filter, replace filter elements, if necessary.



5.18 Instruct operator and maintenance personnel

Before using the pump/pump unit, the personnel must be instructed in using the pump/pump unit, its function, components, documentation and safety.

Danfoss offers commissioning and service at system manufacturer's location. Rate quotes are offered upon request.

6. Operation of motor pump unit

6.1 General safety information

Before inspecting the pump unit, read the Safety chapter 2 in this user manual.

6.2 What to listen and look for

If one or more of the following examples are observed, please act as indicated:

- A) Loose bolts – check all bolts and, if necessary, contact the maintenance department in order to have all bolts tightened to the specified torque(s).
- B) Leakage – if a small leakage from the bell housing is observed. Contact the maintenance department.
- C) Leakage – if there is a large leak, the unit should be stopped immediately. Contact the maintenance department.
- D) High frequency tones – safety/relief valves are either damaged or running very close to their design pressure, stop the unit immediately. Contact the maintenance department.
- E) Increased noise or vibration – requires the unit to be stopped immediately. Contact the maintenance department.
- F) Very high temperatures – may indicate that one or more parts are damaged inside the pump. The pump must be stopped immediately and inspected before it is restarted. Contact the maintenance department.

- G) Drop in flow and/or pressure – may indicate wear on one or more parts inside the pump. The pump must be stopped immediately and inspected before it is restarted. Contact the maintenance department.
- H) Other observations or troubles, please see appendix 7, Right and Wrong or appendix 6, Trouble shooting guide. Both appendices give good advises on design, installation, wiring and troubleshooting.

If the pump is not stopped for inspection as recommended, it can lead to damage of the pump or break-down. See also service and warranty section in appendix 1, Data sheet and appendix 2, Instruction.

Danfoss offers service of the pump at the system manufacturer's location as well as we offer training in how to service the pump. Quotes are offered upon request.

Danfoss recommends simultaneously to check the filter and membrane condition and to evaluate contamination; filter and membrane elements must be replaced if necessary.

7. Maintenance and service of the pump unit

7.1 General safety information

Before servicing the pump unit, it is necessary to read and understand this user manual, especially the Safety, chapter 2. Remember to wear suitable safety equipment according to Safety, chapter 2.

Danfoss offers service of the pump at the system manufacturer's location and training in how to service the pump. Quotes are offered upon request.

7.2 Service and inspection interval for the pump

Maintenance and service intervals are depending on the cleanliness level of the water, hydraulic load and temperature of the pump unit. The most important parameter is the filtration of the water.

See the section Service and warranty in the appendix 1, Data sheet and appendix 2, Instruction.

For spare parts and service tools, please see appendix 4, Parts list.

7.3 Shut down of the system

- A) Stop the high-pressure pump.
- B) Release the pressure.
- C) Stop the feed pump if used.
- D) Switch off the safety circuit breaker for both the high-pressure pump, feed pump and VFD and lock them. Only personnel servicing the pump unit should be able to unlock/activate the switch again.
- E) Open bleeding and drain plugs. Wait until the pump and system are emptied for water.



- F) Slowly unscrew and remove the bolts and gaskets from the inlet/outlet hoses or pipes, be careful about jets of water. Be aware that the system can be pressurized.
- G) Attach the lifting equipment to the pump unit. For instructions on lifting the complete pump unit, see chapter 4, Arrival inspection, transportation, handling, lifting and storage.
- H) For the small pumps, unscrew the bolts holding the pump to the bell housing and for the bigger pumps, unscrew the bolts/nuts from the pump and bell housing to the motor and afterwards unscrew the bolts/nuts holding the pump and bell housing.
- I) Carefully pull the pump out of the bell housing by using lifting equipment, if necessary.
- J) Hold the pump in different positions above a drip tray; this should allow most of the water trapped in the pump to drain. Clean and dry the pump surface and plug the bleeding and draining plugs.
- K) Move the pump to a clean and safe location where the pump can be inspected/ serviced.

7.4 Disassembling and assembling the pump unit

- A) Remove all connections from the pump.
- B) Disassemble the pump according to the Disassembling and Assembling Instruction (available at hpp.danfoss.com). Clean all the parts and surfaces with a fluid compatible with the materials found in the pump. Wipe the parts clean and dry with a lint-free clothing.
- C) Inspect all parts including shaft seal and if necessary, replace them; see appendix 4, Parts list.
- D) If the pump is going to be returned to Danfoss for repair or a warranty claim, it is important to contact Danfoss in order to receive a return number and a form to fill out with product information. A copy of the form together with contact information and reason for returning should be sent to the email address on the form. The same documents should be attached to the shipment.

Product information (see label on product) Only 1 product on each report.		
Product type	Code number	Serial number
Operational conditions		
Application	Inlet pressure	Open pump/motor only
Hours of operation	Outlet pressure	Number of duty cycles (orders only)
Filtration (p. absolute/normal) :	Flow	Water temperature
Water type	SDS	Pumps in parallel (series)

Returns without a return number will be rejected !!!

7.5 Assembling the pump unit

Assemble the pump according to the Disassembling and Assembling Instruction (available at www.danfoss.high-pressurepumps.com).

7.6 Procedure for mounting the pump back onto electric motor



Mount the flexible coupling and bell housing according to appendix 2, Instruction.

7.7 Getting the pump unit back into operation

Find instructions of how to put the pump unit back into operation in chapter 4, Arrival inspection, transportation, handling, lifting and storage and Installation and commissioning, chapter 5.

7.8 Storage of the pump

If the pump has to be shut down for a longer period, instructions can be found in appendix 2, Instruction.

8. Troubleshooting and scrapping criteria

8.1 General safety information

Before inspecting the pump unit, it is necessary to read and understand this user manual, especially the Safety chapter 2.

Remember to wear suitable safety equipment according to Safety chapter 2.

8.2 Operational conditions which can cause pump failures

The following conditions can cause a pump failure :

- The pump is running dry.
- The inlet pressure is too high.
- The inlet pressure is too low.
- The temperature of the fluid is too high.
- The ambient temperature is too high.
- The pump is running against a blocked port/closed manual valve.
- The pump is operating at a pressure out of specification.
- The pump is running with a non-specified/ approved fluid.
- The pump is running in the wrong direction.
- The filtration is insufficient.
- There is excessive mechanical load on the shaft coupling and piping.



Danger Hot
Do not touch

8.3 Mechanical failure

If the pump is running dry, the temperature will quickly increase which can cause burns.

If there is any leakage at start-up or during operation, a high pressure jet can cause eye or skin damage.

Leakage can result in flooding, which can cause slipping, tripping or falling.

If water is dripping into the electric motor; it can cause electric shock, fire, short of circuit or even death. When mounting the pump vertically, always mount the motor above the pump to avoid water leaking into the electric motor.



Electrical hazard

8.4 Electrical failure

If the wiring of the electric motor is incorrect or the ground connection is missing, it can cause electric shock, burn damages, fire or even death.

If a VFD is used and wrongly programmed, it can damage the pump and lead to high temperatures or other dangers.

All electrical installation must be carried out by authorized personnel in accordance with EN60204-1 and/or local regulations.

8.5 Responsibility

Danfoss takes no responsibility for any abnormal injuries, risks or damages that could arise caused by abnormal conditions, vibrations, corrosion, abrasives, foreign objects or excessive temperatures and shall not be liable for any consequential or incidental damages.

8.6 Scrapping criteria

Whether the pump can be repaired or need to be scrapped, depends on in which conditions the internal parts are, or how damaged the whole unit is. Please use appendix 5, Trouble shooting guide as guideline or send the pump to Danfoss headquarter in Denmark for evaluation.

For other observations or troubles, please see appendix 6, Right and Wrong which gives good advises regarding design, installation, wiring and troubleshooting.

In case the pump needs to be scrapped, please follow your local environmental rules.

Operation guide

PAHT C pumps

PAHT C 2-6.3

Appendices for Installation, Operation and Maintenance Manual



Operation guide | Installation, Operation and Maintenance Manual for PAHT C 2-6.3 pumps

Table of Contents	1.	Data sheet PAHT C 2-6.3 pumps (A!234386502982en000401).....	19
	2.	Pump instruction PAHT C 2-6.3pumps (AN234386502875en-000202)	31
	3.	Electric motor manual (180R9230)	43
	4.	Parts list PAHT C 2-6.3 (A!234386502982en000401).....	49
	5.	Trouble shooting guide for PAH / PAHT / PAHT C / PAHT G / PAHT 674 and PAH F pumps.....	57
	6.	Right and wrong - Trouble shooting guide for water hydraulic systems (180R9042).....	69

Data sheet

PAHT C pumps

PAHT C 2 - 6.3

ATEX PAHT C pumps



Table of Contents	Contents
1.	Introduction20
2.	Benefits.....21
3.	Application examples21
4.	Technical data22
4.1	PAHT C 2-6.322
5.	Flow23
5.1	PAHT C 2-6.3 typical flow curves at max pressure (measured in water)23
6.	Motor requirements.....24
7.	Installation.....25
7.1	Filtration25
7.2	Noise25
7.3	Open-system design26
7.4	Closed-system design.....27
8.	Dimensions and connections.....28
8.1	PAHT C 2-6.328
9.	Service.....29

1. Introduction

The Danfoss range of PAHT C is specifically designed for use with technical water mixed with chemicals or media other than water with low viscosity.

Danfoss PAHT pumps are positive displacement pumps, with axial pistons that move a fixed amount of water in each cycle. Flow is proportional to the number of input shaft revolutions (rpm). Unlike centrifugal pumps, they produce the same flow at a given speed independently of the discharge pressure.

The range of PAHT C pumps is based on the standard PAHT pump series. The PAHT C pumps are made with more resistant sealing. These pumps are primarily used in gas turbine water wash applications or other cleaning applications.

This data sheet is valid for PAHT C pumps both non ATEX and ATEX certified. ATEX certified pumps are indicated by Ex in the type designation example PAHT C 2 Ex.

Below sectional drawing is an example of a PAHT pump.

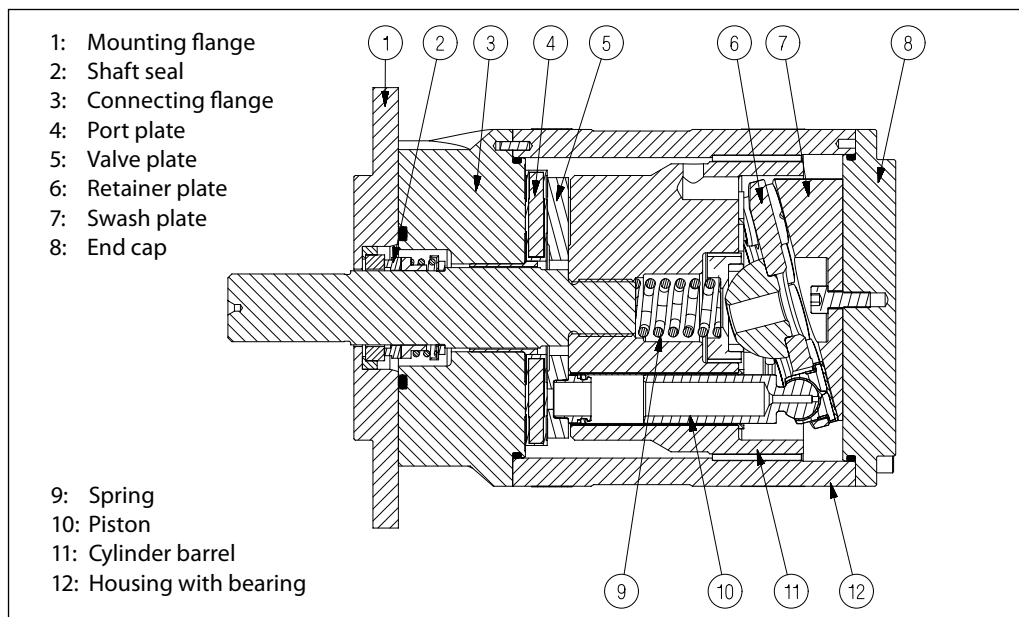

2. Benefits

- **Zero risk of lubricant contamination:**
 - Oil lubricants are replaced with the pumped medium, water, so there is no contamination risk from the pump.
- **Low maintenance costs:**
 - Efficient design and all-stainless steel construction ensure exceptionally long lifetime. When Danfoss specifications are met, service intervals of up to 8,000 hours can be expected. Service is easy, and can be carried out on site due to the simple design and few parts.
- **Low energy costs:**
 - The highly efficient axial piston design provides the lowest energy consumption of any comparable pump on the market.
- **Easy installation:**
 - The lightest and most compact design available.
 - High resistant sealing material available
- Pump can be installed horizontally or vertically.
- No pulsation dampeners necessary due to extremely low-pressure pulsation.
- Powered by electric motors or combustion engines.
- Suitable for both boosted inlet pressure and water supply from a tank.
- No need for cooling circuits due to very high mechanical efficiency.
- **Certified quality:**
 - Fulfills the stringent hygiene requirements, VDI 6022, HACCP.
 - Certificates: ISO 9001, ISO 14001
 - ATEX available on PAHT C, API available on request

3. Application examples

- High-pressure cleaning as used in the manufacturing of flat-panel displays and many other electronic products.
- High-pressure cleaning as used in the manufacturing of parts for the automobile industry.
- Reduction of NOx emissions in gas turbines by cleaning with water wash.

4. Technical data
4.1 PAHT C 2-6.3

Pump size		2	3.2	4	6.3
Code number PAHT C		180B1030	180B1031	180B1032	180B1033
Code number ATEX PAHT C		180B1130	180B1131	180B1132	180B1133
Housing material		AISI 304	AISI 304	AISI 304	AISI 304
Sealing material		FFKM	FFKM	FFKM	FFKM
Geometric displacement	cm ³ /rev	2	3.2	4	6.3
	in ³ /rev	0.12	0.20	0.24	0.38
Pressure					
Min. outlet pressure	barg	30	30	30	30
	psig	435	435	435	435
Max. outlet pressure	barg	100	100	100	100
	psig	1450	1450	1450	1450
Inlet pressure, continuous	barg	0-4	0-4	0-4	0-4
	psig	0-58	0-58	0-58	0-58
Max. inlet ¹⁾ pressure, peak	barg	4	4	4	4
	psig	58	58	58	58
Speed					
Min. speed	rpm	1000	1000	1000	1000
Min. speed, continuous	rpm	1000	1000	1000	1000
Max. speed	rpm	3000	3000	3000	3000
Typical flow - Flow curves available in section 5²⁾					
1000 rpm at max. pressure	l/min	0.7	2.0	3.0	5.5
1500 rpm at max. pressure	l/min	1.7	3.6	5.0	8.6
1200 rpm at max. pressure	gpm	0.3	0.7	1.0	1.8
1800 rpm at max. pressure	gpm	0.6	1.2	1.6	2.7
Typical motor size					
1500 rpm at max. pressure	kW 50 Hz	0.75	1.1	1.5	2.2
1800 rpm at max. pressure	hp 60 Hz	1.0	1.5	2.0	3.0
Torque at max. outlet pressure	Nm	4.4	6.7	8.1	12.4
	lbf-ft	3.2	4.9	6.0	9.2
Media temperature	°C	2-50	2-50	2-50	2-50
	°F	37-122	37-122	37-122	37-122
Ambient temperature	°C	0-50	0-50	0-50	0-50
	°F	32-122	32-122	32-122	32-122
Sound pressure level ³⁾	dB(A)	76	76	76	76
Weight	kg	4.4	4.4	4.4	4.4
	lbs	9.7	9.7	9.7	9.7

¹⁾ 1% per minute peak, 10% per minute during start up.

²⁾ Values measured in water, might differ in other media.

³⁾ Measurements according to EN ISO 3744: 2010 / dB(A) [L_{PA,1m}] values are calculated. Measured at max pressure and rpm for a motor pump unit.

Data sheet | PAHT C 2-6.3 pumps

5. Flow

The flow (Q_{eff}) at various pressure (p_{max}) can be calculated with the following equation:

$$Q_{\text{eff}} = Q_{\text{(th)}} - [(Q_{\text{(th)}} - Q(p_{\text{max}})) \times (p / p_{\text{max}})]$$

The theoretical flow can be calculated with the following equation:

$$Q_{\text{(th)}} = \frac{V \times n}{1000}$$

At zero pressure the true flow equals the theoretical flow $Q_{\text{(th)}}$.

$Q_{\text{(th)}}$:	Theoretical flow (l/min / gpm)
$Q(p_{\text{max}})$:	Flows at max. pressure (l/min and gpm), see 4.1-4.4
p_{max} :	Max pressure (barg / psig)
p :	Pressure (barg / psig)
V :	Displacement ($\text{cm}^3 / \text{rev.}$)
n :	Motor speed (rpm)

5.1 PAHT C 2-6.3 typical flow curves at max pressure (measured in water)

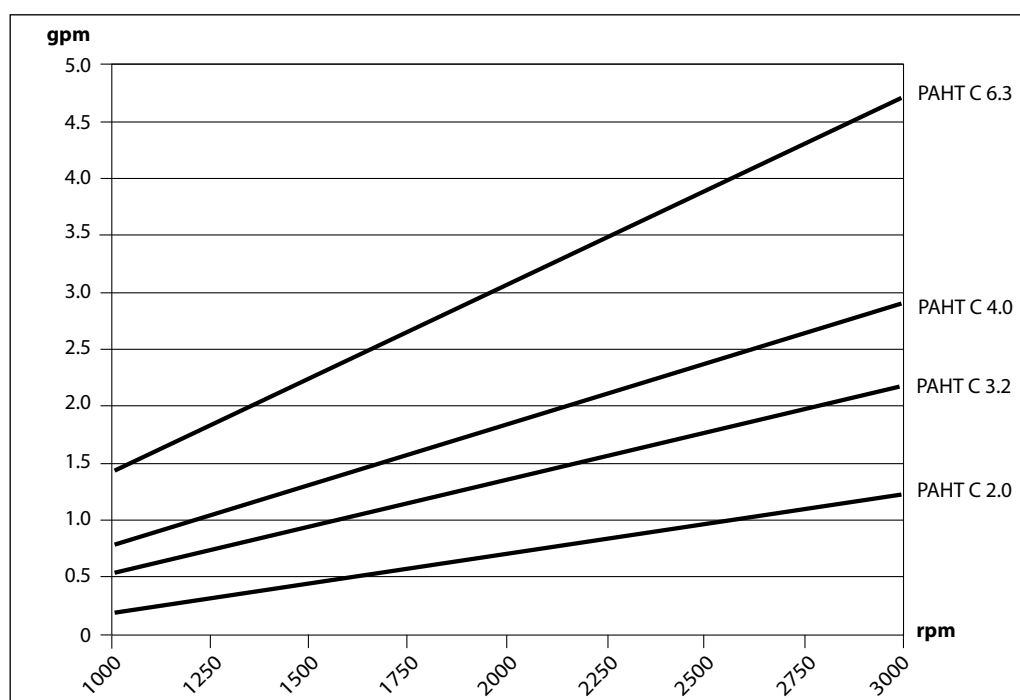
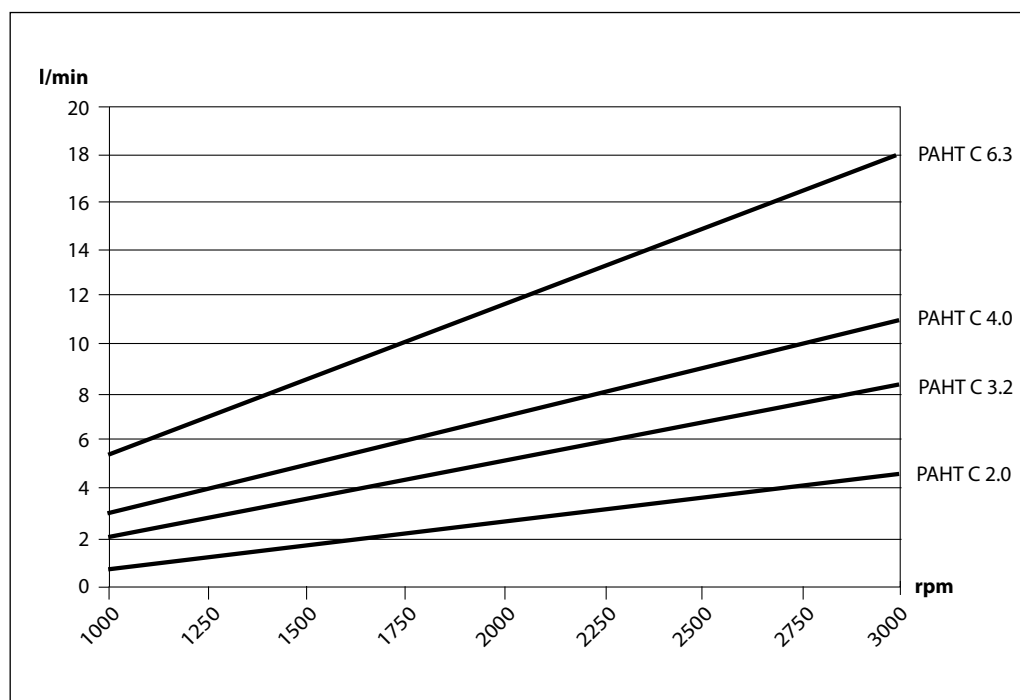

Data sheet | PAHT C 2-6.3 pumps

6. Motor requirements The required motor power can be calculated by using the following equation:

$$P = \frac{n \times V \times p}{600.000 \times \eta}$$

P: Power (kW)
M: Torque (Nm)
η: Mechanical efficiency
p: Pressure (barg)
n: Motor speed (rpm)
V: Displacement (cm³/rev.)

From the flow curves in item 5, you can determine the rpm of the pump at the desired flow.

The required torque is calculated as follows:

$$M = \frac{V \times p}{62.8 \times \eta}$$

To determine the correct motor size, both the power and torque requirement must be verified.

The mechanical efficiency of the pump, at max pressure, is as follows:

PAHT C 2, 3.2, 4, 6.3	0.8
-----------------------	-----

7. Installation

See the figure below for instructions on how to mount the pump and connect it to an electric motor or combustion engine.

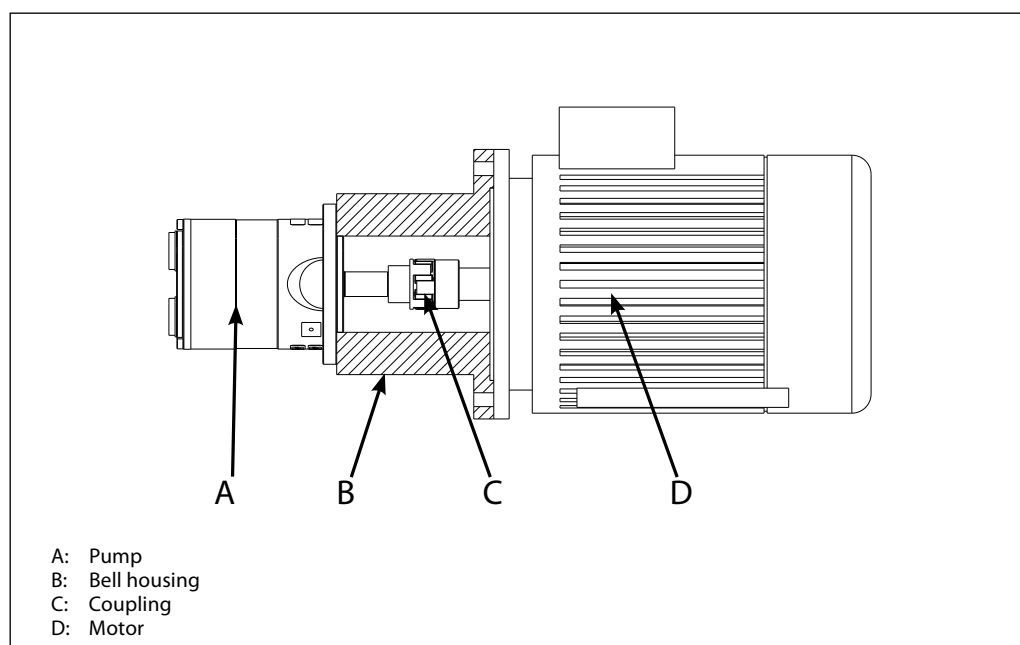

If alternative mounting is required, please contact your Danfoss sales representative for further information.

Note: Do not add any axial or radial loads to the pump shaft.

For more information on the importance of proper filtration, including explanation of filtration principles, definitions, and guidance on how to select the right filter for your pump, please consult our **Filtration** information and specifications (Danfoss document number 521B1009).

7.1 Filtration

Proper filtration is crucial for the performance, maintenance and warranty of your pump.

Protect your pump, and the application in which it is installed, by always ensuring that filtration specifications are met, and by always changing filter cartridges according to schedule.

Since water has very low viscosity, Danfoss PAHT pumps have been designed with very narrow clearances in order to control internal leakage rates and improve component performance. **To minimize wear on the pump, it is therefore essential to filter inlet water properly.**

The main filter must have a filtration efficiency of 99.98% at 10 µm. We strongly recommend that you always use precision depth filter cartridges rated 10 µm abs. $\beta_{10} \geq 5,000$.

Please note that **we do not recommend bag filters or string-wound filter cartridges**, which typically have only 50% filtration efficiency. This means that out of 100,000 particles that enter such filters, 50,000 particles pass right through them; compare this to precision depth filters that are 99.98% efficient, and only allow 20 of the same 100,000 particles to pass through.

7.2 Noise

Since the pump unit is mounted on a frame, the overall noise level can only be determined for a complete system. To minimize vibrations and noise throughout the system, it is therefore very important to mount the pump unit correctly on a frame with dampers and to use flexible hoses rather than metal pipes where possible.

The noise level is influenced by:

- **Pump speed:**
High rpm makes more fluid/structure-borne pulsations/vibrations than low rpm.
- **Discharge pressure:**
High pressures make more noise than low pressures.
- **Pump mounting:**
Rigid mounting makes more noise than flexible mounting because of the structure-borne vibrations. Be sure to use dampers when mounting.
- **Connections to pump:**
Pipes connected directly to the pump make more noise than flexible hoses because of structure-borne vibrations.
- **Variable frequency drives (VFDs):**
Motors regulated by VFDs can produce more noise if the VFD does not have the right settings.

7.3 Open-system design

- A Inlet line:**
Dimension the inlet line to obtain minimum pressure loss (large flow, minimum pipe length, minimum number of bends/connections, fittings with small pressure losses and restrictions).
- B Inlet filter:**
Install the inlet filter (1) in front of the PAHT pump (2). Please consult the Danfoss filter data sheet for guidance on how to select the right filter.
- C Monitoring pressure switch:**
Install the monitoring pressure switch (3) between the filter and the pump inlet. Set the minimum inlet pressure according to specifications described in item 4, technical data. The monitoring pressure switch stops the pump if inlet pressure is lower than the set minimum pressure.
- D Monitoring temperature switch:**
Install the monitoring temperature switch (4) between the filter and the pump, on either side of the monitoring pressure switch. Set the temperature value according to technical data, item 4. The monitoring temperature switch stops the pump if inlet temperature is higher than the set value.
- E Hoses:**
Always use flexible hoses (5) to minimize vibrations and noise.
- F Inlet pressure:**
In order to eliminate the risk of cavitation and other pump damage, pump inlet pressure must be maintained according to specifications described in item 4, technical data.
- G Non-return valve (6):**
Should be installed after the outlet to prevent pump backspin, which may ruin the pump.
- H Pressure relief valve:**
As the Danfoss PAHT pump begins to create pressure and flow immediately after start-up regardless of any counter pressure, a pressure relief valve (7) should be installed to prevent system damage.
- I Drain:**
Always install a proper drain (8) in order to safely drain the fluid to avoid vaporization and to ensure a safe drain, without human contact before inspection and/or service.

Note: If a non-return valve is mounted in the inlet line, a low-pressure relief valve is also recommended between the non-return valve and the pump to protect against high-pressure peaks.

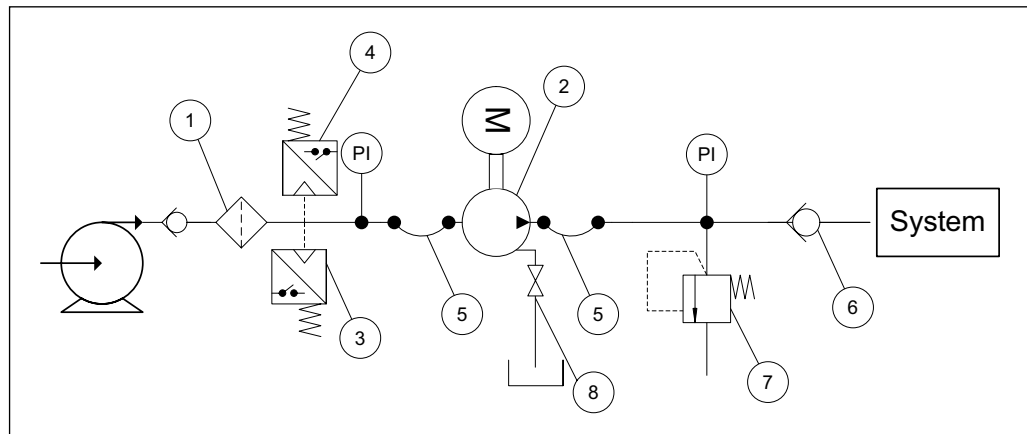

7.4 Closed-system design

- A Inlet line:**
Dimension the inlet line to obtain minimum pressure loss (large flow, minimum pipe length, minimum number of bends/connections, fittings with small pressure losses and restrictions).
- B Inlet filter:**
Install the filter (1) in front of the tank (2). Please consult the Danfoss filter data sheet for guidance on how to select the right filter.
- C Monitoring pressure switch:**
Install the monitoring pressure switch (3) in front of the filter (1). Set the maximum inlet pressure to 2 barg (29.0 psig). The monitoring pressure switch will stop the pump (5) if inlet pressure is higher than 2 barg (29.0 psig), indicating that the filter element must be changed.
- D Monitoring temperature switch:**
Install the monitoring temperature switch (4) in the tank. Set the temperature value according to technical data, item 4. The monitoring temperature stops the pump if inlet temperature is higher than the set value.
- E Hoses:**
Always use flexible hoses (6) to minimize vibrations and noise.
- F Inlet pressure:**
In order to eliminate the risk of cavitation and other pump damage, pump inlet pressure must be maintained according to specifications described in item 4, technical data.
- G Non-return valve (7):**
Should be installed after the outlet to prevent pump backspin, which may ruin the pump.
- H Pressure relief valve:**
As the Danfoss PAHT pump begins to create pressure and flow immediately after start-up regardless of any counter pressure, a pressure relief valve (8) should be installed to prevent system damage.
- I System water filling:**
To ensure proper filtration of new water (10) supplied to the system, always use the filling valve (9).
- J Minimum level switch:**
Install the minimum level switch (11) above the outlet of the reservoir. The level switch must stop the pump if the water in the reservoir is below the switch, which indicates that the reservoir is empty.
- K Drain:**
Always install a proper drain (12) in order to safely drain the fluid to avoid vaporization and to ensure a safe drain, without human contact before inspection and/or service.

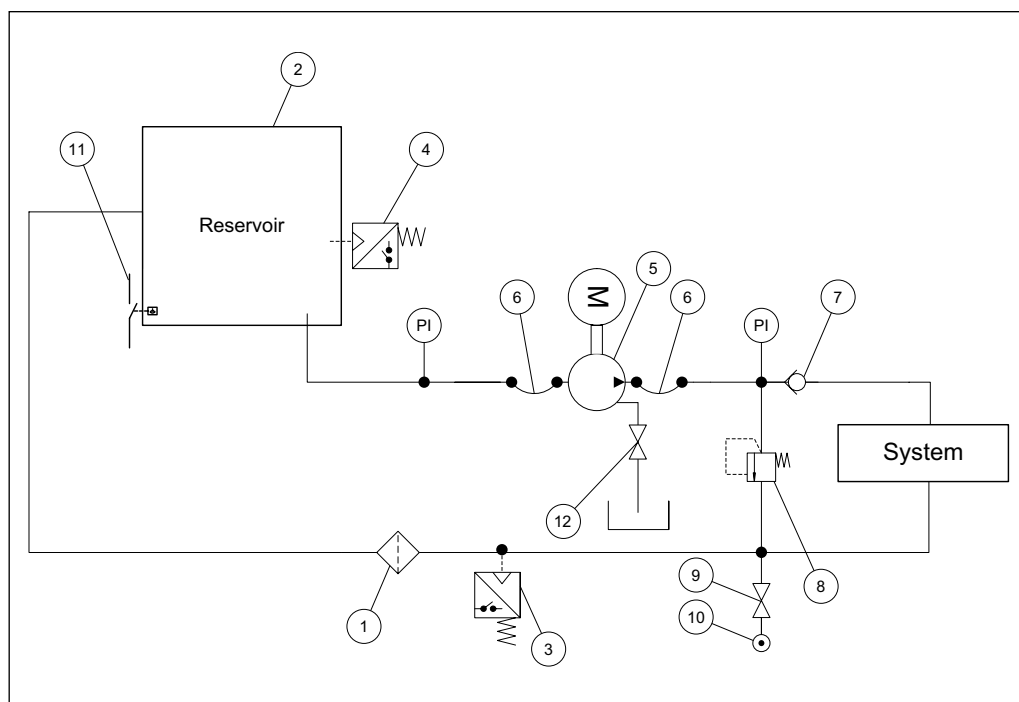

8. Dimensions and connections 8.1 PAHT C 2-6.3

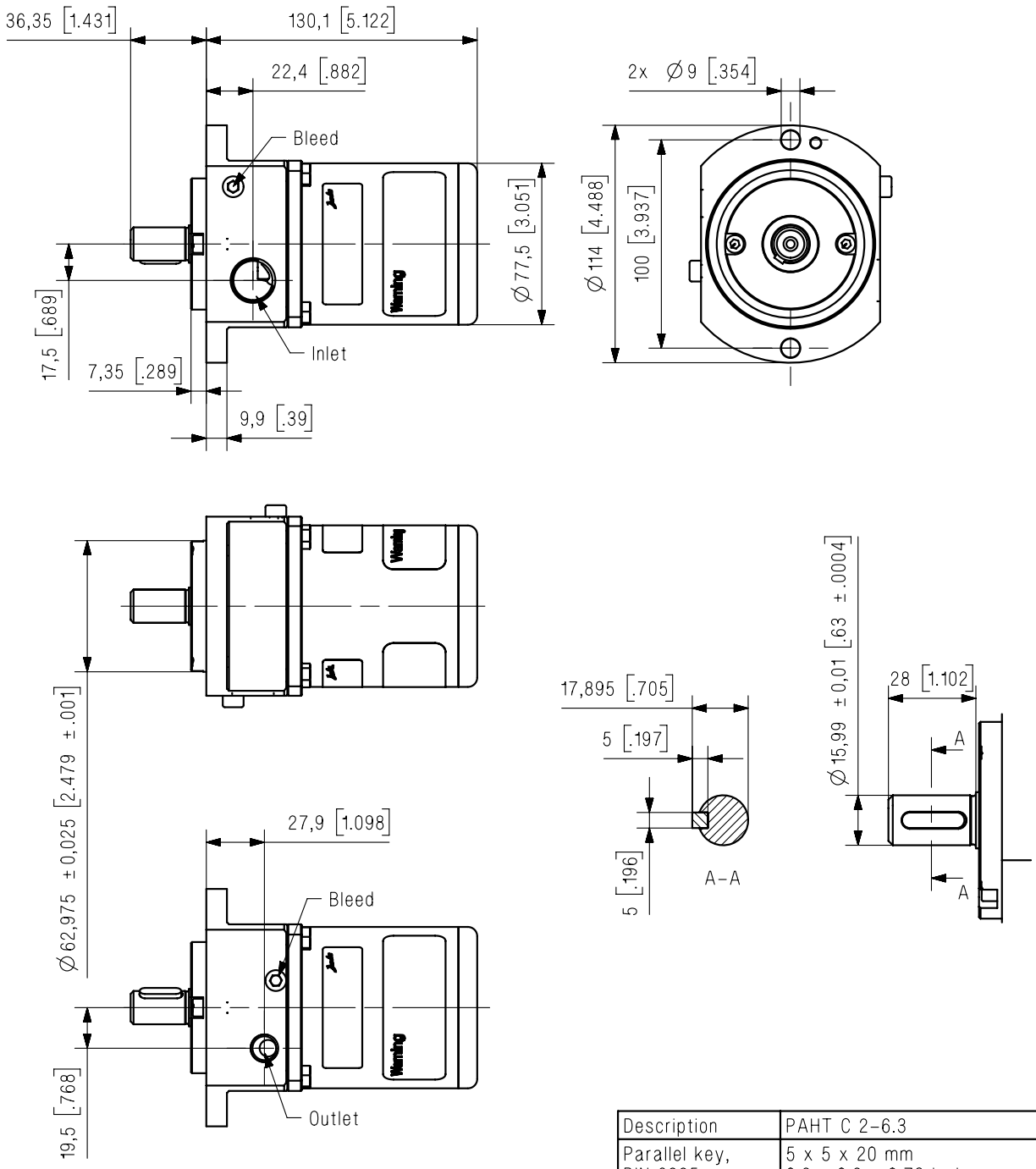

Dimensions without tolerances acc. to ISO 2768-1 designation C.

Description	PAHT C 2-6.3
Parallel key, DIN 6885	5 x 5 x 20 mm 0.2 x 0.2 x 0.79 inch
Bleed	M6; hex key 4 mm M6; hex key 5 mm
Inlet port	G 1/2" BSPP; depth 15 mm
Outlet port	G 1/4" BSPP; depth 11 mm
Mounting flange	ISO 3019-2 63A2HW

9. Service

Danfoss PAHT C pumps are designed for long periods of service-free operation to ensure low maintenance and life cycle costs. Provided that the pump is installed and operated according to Danfoss specifications, Danfoss PAHT C pumps typically run 8,000 hours between service (Validated in water). However, the service schedule for your PAHT C pump may vary according to the application and other factors. Some chemicals might change the surface tension which the pumps are relying on and therefore decrease the service intervals.

The life of a pump may be greatly shortened if Danfoss recommendations concerning system design and operation are not followed.

In our experience, poor filtration is the number one cause of pump damage.

Other factors that affect the pump performance and lifetime include:

- Running the pump speeds outside specifications
- Supplying the pump with temperatures higher than recommended
- Running the pump at inlet pressures outside specifications
- Running the pump at outlet pressures outside the specifications

We recommend that you inspect your pump after 8,000 hours of operation even if it is running without any noticeable problems. Replace any worn parts if necessary, including pistons and shaft seals, to keep your pump running efficiently and to prevent breakdown. If worn parts are not replaced, then our guidelines recommend more frequent inspection.

Make sure to install a proper drain to avoid any spill of fluid into the surroundings, drain the whole pump before servicing and wear necessary safety equipment.

Read the Service Instruction before servicing the pump.

Danfoss A/S

High Pressure Pumps • danfoss.com • +45 7488 2222 • highpressurepumps@danfoss.com

Any information, including, but not limited to information on selection of product, its application or use, product design, weight, dimensions, capacity or any other technical data in product manuals, catalogues descriptions, advertisements, etc. and whether made available in writing, orally, electronically, online or via download, shall be considered informative, and is only binding if and to the extent, explicit reference is made in a quotation or order confirmation. Danfoss cannot accept any responsibility for possible errors in catalogues, brochures, videos and other material. Danfoss reserves the right to alter its products without notice. This also applies to products ordered but not delivered provided that such alterations can be made without changes to form, fit or function of the product.

All trademarks in this material are property of Danfoss A/S or Danfoss group companies. Danfoss and the Danfoss logo are trademarks of Danfoss A/S. All rights reserved.

Instruction

PAHT C pumps

PAHT C 2/3.2/4/6.3



Instruction Pump instruction PAHT C 2-6.3

Table of Contents

Contents1

- Identification32
- 2. System design33
 - 2.1 Closed-system design.....33
 - 2.2 Open-system design34
 - 2.3 General guidelines for calculation of pressure losses35
 - 2.4 General comments on.....35
- 3. Building up the pump unit36
 - 3.1 Mounting.....36
 - 3.2 Direction of rotation36
 - 3.3 Orientation36
 - 3.4 Protection from too high pressure37
 - 3.5 Connections37
- 4. Initial start-up.....38
- 5. Operation.....38
 - 5.1 Water quality38
 - 5.2 Temperature.....38
 - 5.3 Pressure38
 - 5.4 Dry running.....38
 - 5.5 Disconnection38
 - 5.6 Storage.....38
 - 5.6.1 Water hydraulic systems, water recirculated.....38
 - 5.6.2 Open-ended systems with water supply from tank.....39
 - 5.6.3 Open-ended systems with direct water supply.....39
- 6. Service.....39
- 7. Recommended service intervals.....40
 - 7.1 General information.....40
 - 7.2 Inspection of pump parts40
 - 7.3 How to inspect the pump40

1. Identification

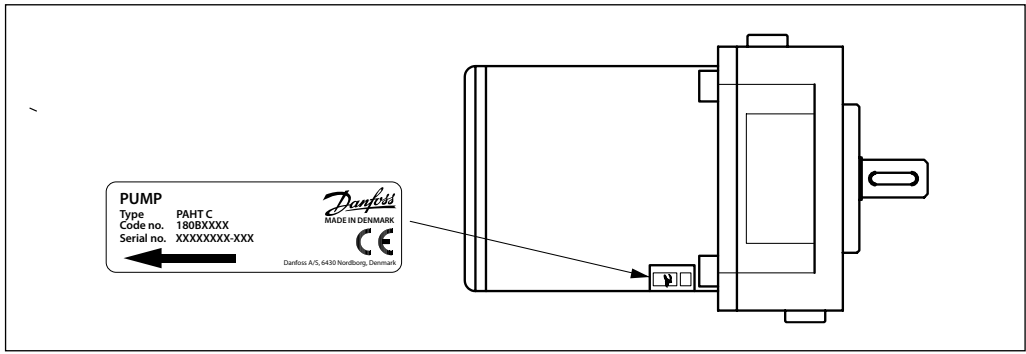

2. System design

2.1 Closed-system design

- A Inlet line:**
Dimension the inlet line to obtain minimum pressure loss (large flow, minimum pipe length, minimum number of bends/connections, fittings with small pressure losses and restrictions).
- B Inlet filter:**
Install the filter (1) in front of the tank (2). Please consult the Danfoss filter data sheet for guidance on how to select the right filter.
- C Monitoring pressure switch:**
Install the monitoring pressure switch (3) in front of the filter (1). Set the maximum inlet pressure to 2 barg (29.0 psig). The monitoring pressure switch will stop the pump (5) if inlet pressure is higher than 2 barg (29.0 psig), indicating that the filter element must be changed.
- D Monitoring temperature switch:**
Install the monitoring temperature switch (4) in the tank. Set the temperature value according to technical data, item 4. The monitoring temperature stops the pump if inlet temperature is higher than the set value.
- E Hoses:**
Always use flexible hoses (6) to minimize vibrations and noise.
- F Inlet pressure:**
In order to eliminate the risk of cavitation and other pump damage, pump inlet pressure must be maintained according to specifications described in item 4, technical data.
- G Non-return valve (7):**
Should be installed after the outlet to prevent pump backspin, which may ruin the pump.
- H Pressure relief valve:**
As the Danfoss PAHT pump begins to create pressure and flow immediately after start-up regardless of any counter pressure, a pressure relief valve (8) should be installed to prevent system damage.
- I System water filling:**
To ensure proper filtration of new water (10) supplied to the system, always use the filling valve (9).
- J Minimum level switch:**
Install the minimum level switch (11) above the outlet of the reservoir. The level switch must stop the pump if the water in the reservoir is below the switch, which indicates that the reservoir is empty.
- K Drain:**
Always install a proper drain (12) in order to safely drain the fluid to avoid vaporization and to ensure a safe drain, without human contact before inspection and/or service.

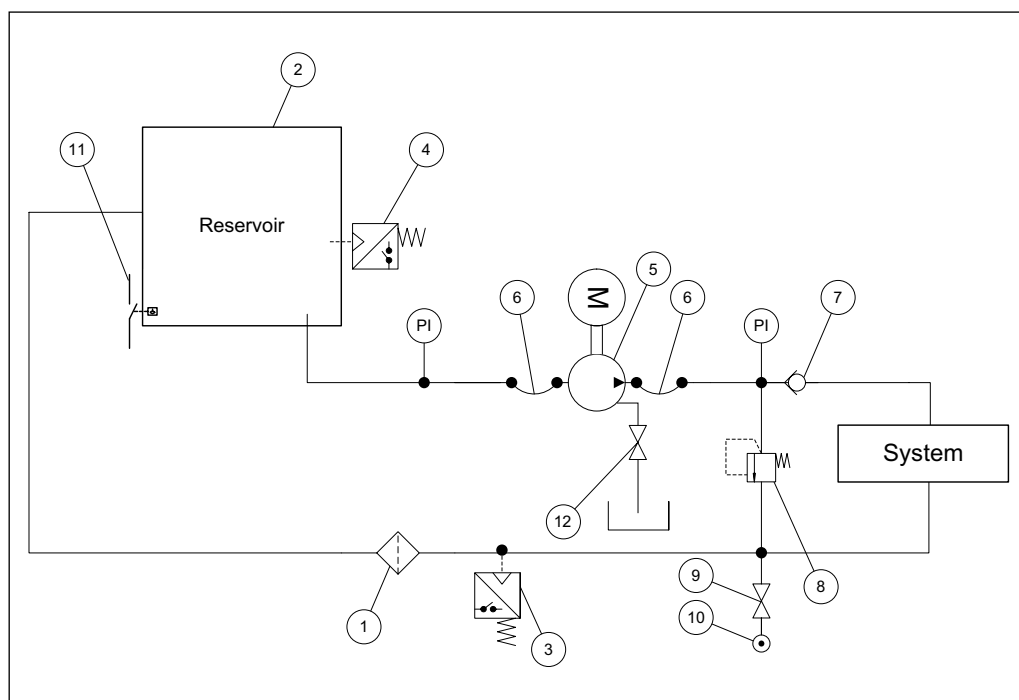

2.2 Open-system design

- A Inlet line:**
Dimension the inlet line to obtain minimum pressure loss (large flow, minimum pipe length, minimum number of bends/connections, fittings with small pressure losses and restrictions).
- B Inlet filter:**
Install the inlet filter (1) in front of the PAHT pump (2). Please consult the Danfoss filter data sheet for guidance on how to select the right filter.
- C Monitoring pressure switch:**
Install the monitoring pressure switch (3) between the filter and the pump inlet. Set the minimum inlet pressure according to specifications described in item 4, technical data. The monitoring pressure switch stops the pump if inlet pressure is lower than the set minimum pressure.
- D Monitoring temperature switch:**
Install the monitoring temperature switch (4) between the filter and the pump, on either side of the monitoring pressure switch. Set the temperature value according to technical data, item 4. The monitoring temperature switch stops the pump if inlet temperature is higher than the set value.
- E Hoses:**
Always use flexible hoses (5) to minimize vibrations and noise.
- F Inlet pressure:**
In order to eliminate the risk of cavitation and other pump damage, pump inlet pressure must be maintained according to specifications described in item 4, technical data.
- G Non-return valve (6):**
Should be installed after the outlet to prevent pump backspin, which may ruin the pump.
- H Pressure relief valve:**
As the Danfoss PAHT pump begins to create pressure and flow immediately after start-up regardless of any counter pressure, a pressure relief valve (7) should be installed to prevent system damage.
- I Drain:**
Always install a proper drain (8) in order to safely drain the fluid to avoid vaporization and to ensure a safe drain, without human contact before inspection and/or service.

Note: If a non-return valve is mounted in the inlet line, a low-pressure relief valve is also recommended between the non-return valve and the pump to protect against high-pressure peaks.

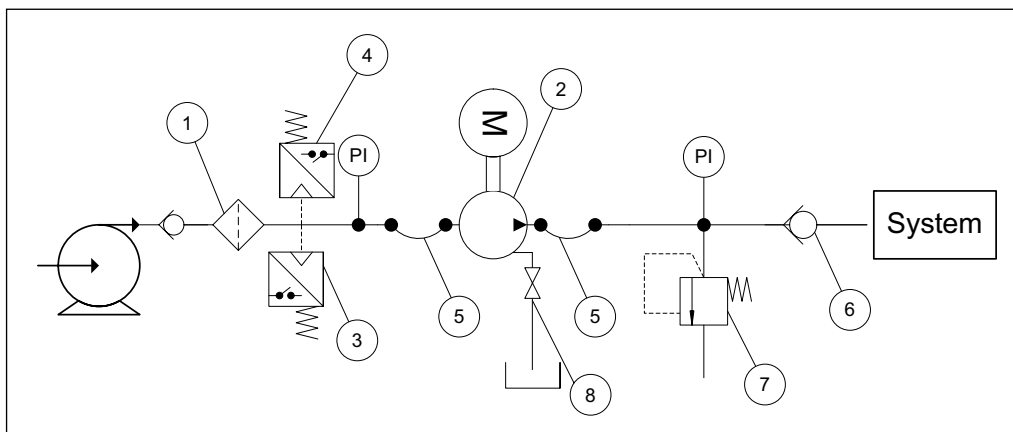

2.3 General guidelines for calculation of pressure losses

The suction conditions can be optimized according to below guidelines.

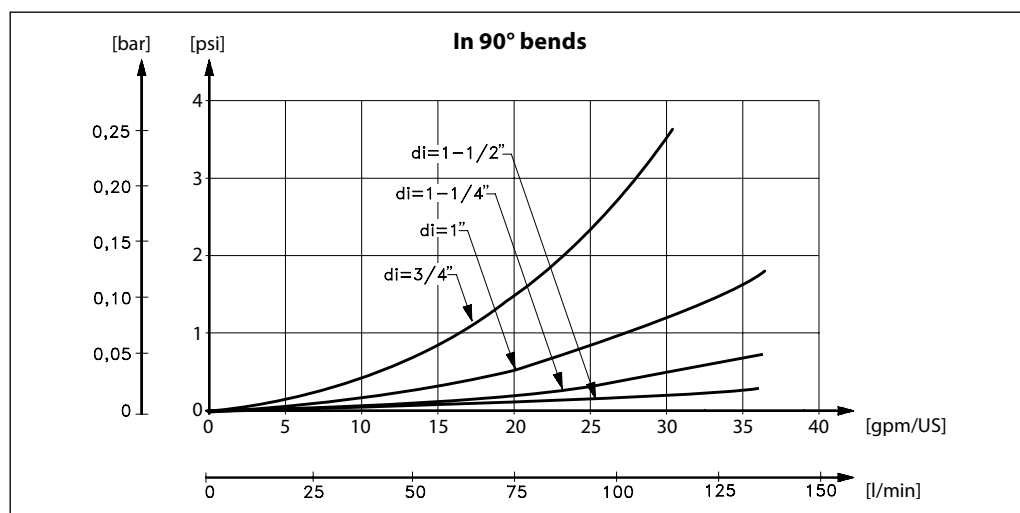
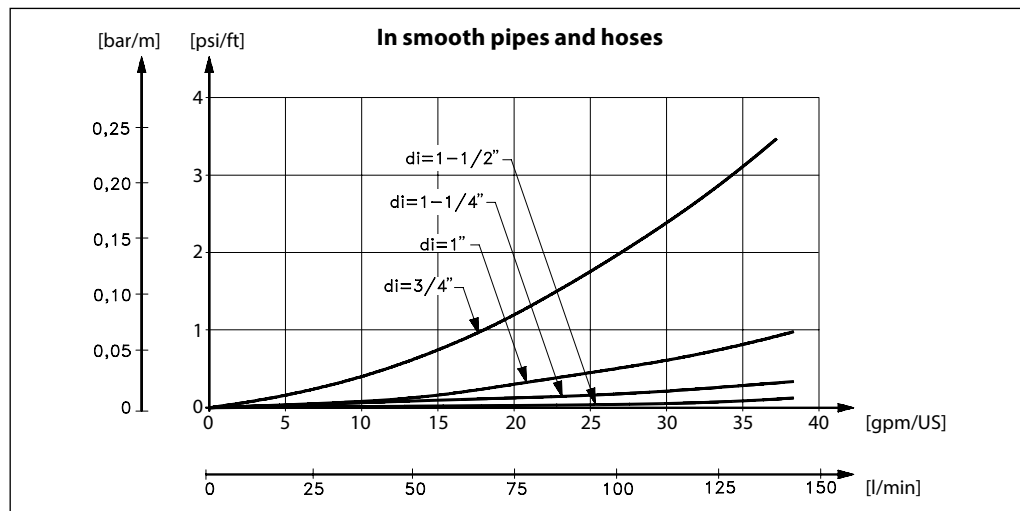

2.4 General comments on

Filtration

A good filtration is vital to ensure a long and trouble free operation of the pump.

When selecting a filter or strainer, please note that filter materials should be compatible with water, i.e. should neither corrode or dissolve. Also be aware of the electrochemical series of the applied materials.

- Main filter must have a fineness of 10 μm abs. $\beta_{10} \geq 5,000$
- The pressure loss across the filter should be monitored
- Please contact the Danfoss Sales Organization for further filter details

Water tank

Must be made of corrosion-proof material such as stainless steel or plastic and must be sealed to prevent entrance of impurities from the environment.

Automatic pressure equalization between tank and surroundings must be ensured.

Inlet from the water supply (the return line) and inlet to the pump should be placed in opposite ends of the tank to calm and deaerate the water, and to ensure optimum opportunity for particles to settle.

Pump suction line should be placed above the tank bottom in order to prevent settled particles from being led into the pump.

We recommend a separation (“wall”) to separate the inlet from the outlet end of the tank.

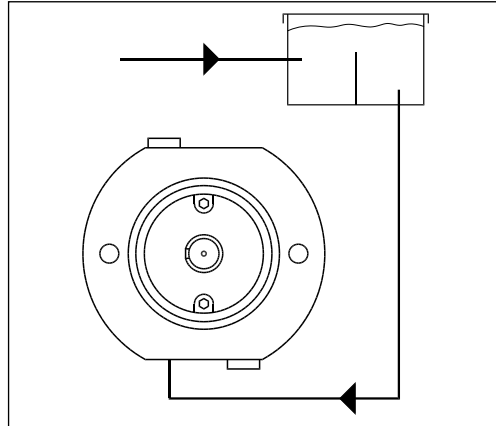

Monitoring

It is recommended to continuously monitor the following conditions:

- Water level in the tank
- Filter contamination
- Pressure (inlet- and outlet side of the pump)

3. Building up the pump unit

3.1 Mounting

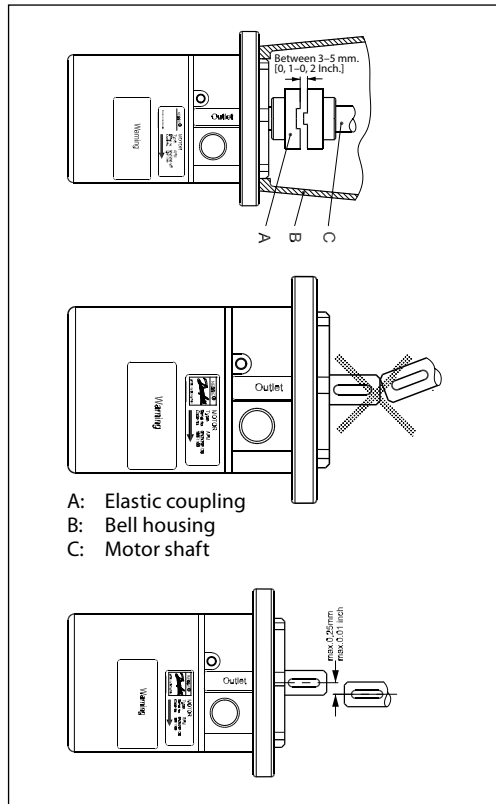

- A: Elastic coupling
 B: Bell housing
 C: Motor shaft

If alternative mounting is desired, please contact the Danfoss Sales Organization.

Choose proper tolerances to ensure an easy mounting of the elastic coupling without use of tools.

Please take care to observe the recommended length tolerances of the chosen coupling, as an axial force on the pump shaft must be avoided.

3.2 Direction of rotation

Is indicated by means of an arrow at the label of the pump.

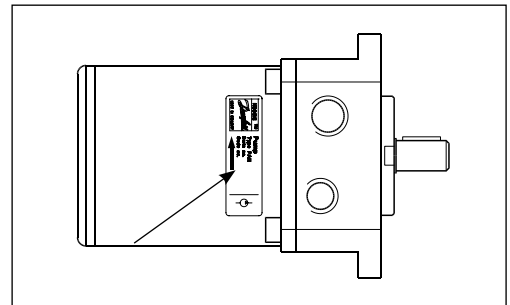

3.3 Orientation

The pump can be mounted/orientated in any direction.

3.4 Protection from too high pressure

The pump should be protected against too high pressure by means of a pressure relief valve or a bypass/unloading valve placed on the pressure side.

The valve should be placed as close to the pump as possible.

The opening characteristics of the valve must not result in peak pressures higher than 200 bar (2900 psi).

The valve outlet must not be connected directly to the pump suction line. It shall be connected directly to the tank.

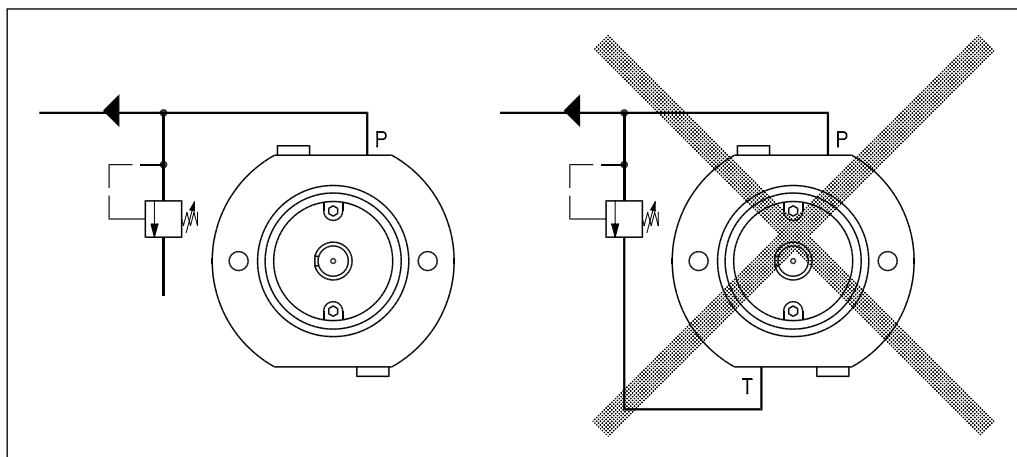

3.5 Connections

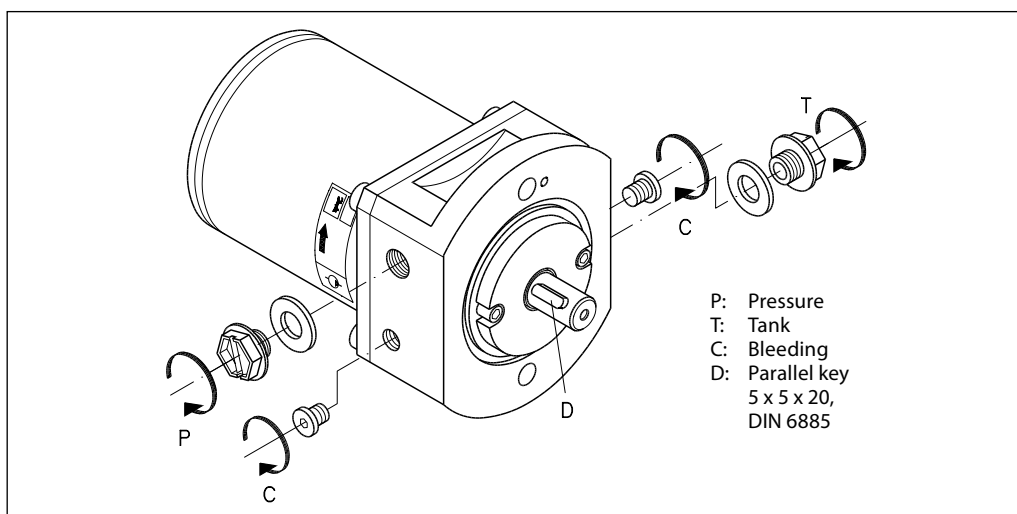

	PAHT C 2-6.3		
	P	T	C
Thread size	G 1/4 x 11	G 1/2 x 15	M6; Allen key 4 mm
Max tighten torque	25 Nm	25 Nm	5 Nm

Recommended torque values refer to steel washers containing a rubber sealing element.

4. Initial start-up

Before start-up, loosen the top bleeding plug "C". When water appears from the bleeding plug, retighten the plug. With its inlet line connected to the water supply or the tank, the pump is now started with open outlet port.

At the initial start of the system, the pump should be run without pressure for about 5 minutes, thus removing possible impurities from pipes, hoses, etc. However, the system should be flushed before start-up.

Warning:
Make sure that the direction of rotation of the electric motor corresponds to the direction of rotation of the pump. Otherwise the pump will be damaged if a check valve is placed between pump and tank.

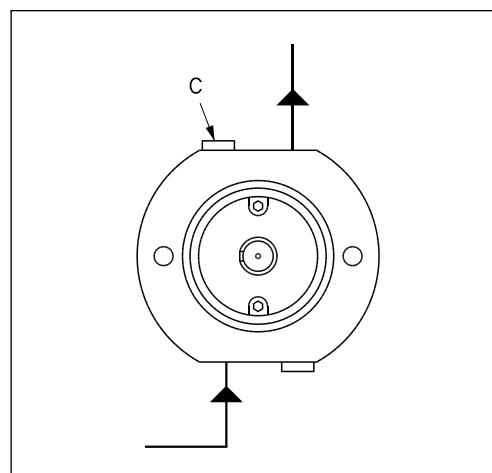
5. Operation
5.1 Water quality

Water of drinking water quality, confirming to the EEC directive 98/83/EC and without abrasive sediments. Please contact Danfoss sales organization in case of doubt.

5.2 Temperature

Fluid temperature	Min. +2°C to max. +50°C
Ambient temperature	Min. 0°C to max. 50°C
Storage temperature	Min. -40°C to max. +70°C

In case of lower operating temperatures, please contact the Danfoss Sales Organization.

5.3 Pressure

The inlet pressure must be between min. 0 barg/0 psig and max. 4 barg/60 psig. The use of pump outside this range damage the pump.

Max. pressure on the pump's outlet line should be limited at 140 barg (2030 psig) continuously. Short-term pressure peaks (e.g. in connection with closing of a valve) of up to 200 barg (2900 psig) are acceptable.

NB: The pump unit should include a pressure gauge on the high pressure side.

5.4 Dry running

When running, the pump must always be connected to the water supply in order to avoid damage if it should run dry.

In systems with water tank it is recommended to build in a level gauge in the tank to avoid the risk of running dry.

5.5 Disconnection

If the inlet line is disconnected from the water supply, the pump will be emptied of water through the disconnected inlet line.

When starting up again, follow the bleeding procedure described under section 4: Initial start up.

5.6 Storage

When preparing the pump for long-term storage or for temperatures below the freezing point, flush the pump with an anti-freeze medium type monopropylene glycol to prevent internal corrosion or frost in the pump. For further information on anti-freeze media, please contact the Danfoss Sales Organization.

Recommended procedure
5.6.1 Water hydraulic systems, water recirculated

1. Disconnect the power pack from the system.
2. Empty the tank of water. Fill up the tank with anti-freeze medium to a level well above the suction line.
3. Start up the power pack and, for a couple of minutes, in a closed loop system let the anti-freeze medium run back to tank through the pressure relief valve or the bypass valve.
4. Empty the tank of the anti-freeze medium. Empty the pump through the lower bleeding plug.

The pump is now protected against internal corrosion and frost.

5.6.2 Open-ended systems with water supply from tank.

1. Empty the tank of water and empty the pump housing through the lower bleeding plug. When the pump is empty, retighten the plug.
2. Through the upper bleeding plug, fill the pump housing with anti-freeze medium. Pour anti-freeze medium into the tank. Connect a hose to the outlet of the pump and lead the other end of the hose back to tank.
3. Quickly start and stop the pump. Make sure that the pump does not run dry.

The pump is now protected against internal corrosion and frost.

5.6.3 Open-ended systems with direct water supply.

1. Disconnect the water supply to the pump.
2. Through the lower bleeding plug, empty the pump housing of water and close it again.
3. Connect the pump to a tank of e.g. 25 litre/ 6 gal. of anti-freeze additive. Connect a hose to the inlet port of the pump and via another hose return the flow from the outlet port to the tank with anti-freeze additives.
4. Quickly start and stop the pump. Make sure that the pump does not run dry.

The pump is now protected against internal corrosion and frost.

6. Service

Danfoss PAHT C pumps are designed for long periods of service-free operation to ensure low maintenance and life cycle costs. Provided that the pump is installed and operated according to Danfoss specifications, Danfoss PAHT C pumps typically run 8,000 hours between service (Validated in water). However, the service schedule for your PAHT C pump may vary according to the application and other factors. Some chemicals might change the surface tension which the pumps are relying on and therefore decrease the service intervals.

The life of a pump may be greatly shortened if Danfoss recommendations concerning system design and operation are not followed.

In our experience, poor filtration is the number one cause of pump damage.

Use of some chemicals, might reduce the service intervals.

Other factors that affect the pump performance and lifetime include:

- Running the pump speeds outside specifications
- Supplying the pump with temperatures higher than recommended
- Running the pump at inlet pressures outside specifications
- Running the pump at outlet pressures outside the specifications

We recommend that you inspect your pump after 8,000 hours of operation even if it is running without any noticeable problems. Replace any worn parts if necessary, including pistons and shaft seals, to keep your pump running efficiently and to prevent breakdown. If worn parts are not replaced, then our guidelines recommend more frequent inspection.

Make sure to install a proper drain to avoid any spill of fluid into the surroundings, drain the whole pump before servicing and wear necessary safety equipment.

Read the Service Instruction before servicing the pump.

7. Recommended service intervals**7.1 General information**

This guideline provides information on the recommended service intervals for the PAHT C pumps. The recommendation is based upon good engineering practice and on experience gained from operation even under extreme conditions.

The recommendation is for guidance only.

7.2 Inspection of pump parts

Danfoss recommends to inspect the pumps after 8,000 hours (validated in water). Typical signs of wear are seen on the contact/sliding surfaces in the pumps. If the pumps must run for additional 8,000 hours, the following parts will have to be inspected:

- Pistons
- Retainer plate, ball and bearing
- Valve plate
- Port plate
- Sealings

If there are any wear marks on the parts they need to be replaced.

If service inspection due to the application is complicated, the plant operator can decide to extend the service interval by evaluating the following deviations:

- Sound - does the pump have any unusual sounds?
- Electric motor power consumption and speed compared with measurement made in the past.
- Pressure/flow according to measurements made in the past?

We advise that the above mentioned parameter during the extended service interval is inspected for every 500-2,000 hours beyond the 8,000 hours. The pump must in any case be inspected after maximum 16,000 hours or 2 years.

7.3 How to inspect the pump

Service manuals are available on the internet hpp.danfoss.com

Danfoss A/S
High Pressure Pumps
Nordborgvej 81
DK-6430 Nordborg
Denmark

Danfoss can accept no responsibility for possible errors in catalogues, brochures and other printed material. Danfoss reserves the right to alter its products without notice. This also applies to products already on order provided that such alterations can be made without subsequential changes being necessary in specifications already agreed. All trademarks in this material are property of the respective companies. Danfoss and the Danfoss logotype are trademarks of Danfoss A/S. All rights reserved.



Electric Motors

Motor Manual

hoyermotors.com

Manual

HOYER

MOTORS

180R9230

1. General

This manual concerns the following types of standard induction motors from Hoyer:

HMA2, HMC2, HMD, HMT, MS, Y2E1, Y2E2, YDT

These motors are manufactured in accordance with IEC/EN 60034-4 and IEC/EN 60072.

Motors are rated for the ambient temperature range -20°C to $+40^{\circ}\text{C}$ and site altitudes ≤ 1000 m above sea level.

Low-voltage motors are components for installation in machinery. They are CE marked according to the Low Voltage Directive 2006/95/EC

2. Transport and storage

Check the motor for external damage immediately upon receipt and, if found, inform the forwarding agent right away. Check all rating plate data, and compare it with the requirement of the motor.

Turn the shaft by hand to check free rotation, remove transport locking if used.

Transport locking must be used again for internal transport also. It is also important that transport locking is used when motors are transported mounted on equipment.

All motors should be stored indoors, in dry, vibration- and dust-free conditions.

Lifting eyebolts must be tightened before use. Damaged eyebolts must not be used, check before use. Lifting eyes at motor must not be used to lift the motor when it is attached to other equipment.

Before commissioning, measure the insulation impedance. If values are $\leq 10\text{M}$ at 25°C , the winding must be oven dried. The insulation resistance reference is halved for each 20°C rise in motor temperature.

It is recommended that shafts are rotated periodically by hand to prevent grease migration.

3. Installation

The motor must be fixed on a stable, clear and flat foundation. It must be sufficiently rigid to withstand possible short circuit forces.

It is important to ensure that the mounting conditions do not cause resonance with the rotational frequency and the doubled supply frequency.

Only mount or remove drive components (pulley, coupling, etc.) using suitable tools, never hit the drive components with a hammer as this will cause damage to the bearing.

The motor are balancing with half key, ensure that the drive components are also the same.

Correct alignment is essential to avoid bearing, vibration and shaft failure.

Use appropriate methods for alignment.

Re-check the alignment after the final tightening of the bolts or studs.

Check that drain holes and plugs face downwards. We recommend opening the drain hole for motors placed outdoors and not running 24 hours / day, so that the motor can breathe, thus ensuring a dry motor.

4. Electrical connection

Work is only permitted to be carried out by qualified specialists and must to be carried out in accordance with local regulations.

Before work commences, ensure that all power is switched off and cannot be switched on again. This also applies to the auxiliary power circuits, e.g. anti-condense heaters.

Check that supply voltage and frequency are the same as rated data.

Motors can be used with a supply deviation of $\pm 5\%$ voltage and $\pm 2\%$ frequency, according to IEC60034-1

Connection diagrams for main supply and accessory as PTC or heater are located inside the terminal box.

Connections must be made in such a way as to ensure that a permanently safe electrical connection is maintained, both for the main supply and the earth connection.

We recommend that crimped connections are made in accordance with IEC 60352-2.

Tightening torques for terminal board screws:

Thread	M5	M6	M8	M10	M12	M16	M20
T.(Nm)	2.5	3.5	7	12	18	35	55

Ensure that the terminal box is clean and dry.

Unused glands must be closed.

Check the terminal box gasket before it is remounted.

5. Maintenance

Inspect the motor at regular intervals, keep it clean and ensure free ventilation air flow, check the condition of shaft seals and replace if necessary. Both electrical and mechanical connections must be checked and tightened if necessary.

Bearing size and type are specified on the rating plate. Motor types HMA2 and HMC2 is as standard with lifetime greased bearing with motor size ≤ 225 .

Motor types MS and Y2E is as standard with lifetime greased bearing with motor size ≤ 160 .

Typical duty hours for lifetime lubricated bearings.

Frame size	Poles	Typical lifetime
56 – 160	2 – 8	40.000h
180	2	35.000h
200	2	27.000h
225	2	23.000h
180 – 225	4 – 8	40.000h

Motors with a re-greasing system must be lubricated with high quality lithium complex grease, NLGI grade 2 or 3, with a temperature range of between -40°C to $+150^{\circ}\text{C}$.

Motors are normal fitted with a data plate with greasing information; if it is missing use the following re-greasing intervals.

Frame size	Grease (g)	2 pole (h)	4 pole (h)	6 pole (h)	8 pole (h)
160	20	4200	7000	8500	8500
180	20	4200	7000	8500	8500
200	25	3100	6500	8500	8500
225	25	3100	6500	8500	8500
250	35	2000	6000	7000	7000
280	35	2000	6000	7000	7000
315	50	1500	5500	6500	6500
355	60	1000	4000	5000	6000
400	80	800	3000	4000	6000

Grease the motor while running, open the grease outlet plug and let the motor run 1-2 hours before the outlet grease plug is closed again.

Grease the motor for the first time during commissioning.

The following applies in general for both lifetime lubricated and re-lubricated bearings:

At 60Hz the time will be reduced by app. 20%.

Data for vertically mounted motors are half of the above values.

The table values are based on an ambient temperature of 25°C . The values must be halved for every 15K increase in bearing temperature.

Higher speed operations, e.g. frequency converter drive will require shorter greasing intervals. Typically, doubling the speed will reduce the values by 50%.

6. Special note for Atex Zone 22 motors.

Notice for the use of electrical equipment in areas with combustible dust.

Designation of motor according to EC directive:

Ex II 3D T125°C, IP55.

The dust hazardous 3-phase asynchronous motors are in accordance with European standard EN 50281-1-1. Combustible dust areas will be found in agricultural areas and in industrial environments.

Only one electrical installation may be installed in one specified area (zone).

Only certificated cable glands for category 2D may be used. Unused glands must be closed.

Connections must be made in such a way as to ensure that a permanently safe electrical connection is maintained, both for the main supply and earth connection.

Installations must be in accordance with actual standards for installation in the Zone 22 area.

It is recommended that EN 50281-2 is followed according temperature and dust on the motor surface.

The use of motors with so much surface dust that the motor temperature increases is not permitted.

Regularly cleaning is recommended.

The radial shaft sealing ring is part of the ATEX certification. It is important that the ring is always intact.

The shaft sealing must be regularly checked, and if dry it must be lubricated. It is recommended that the seal is re-lubricated regularly.

Always use the original seal ring when replaced.

Replacing bearings also means replacing the seals.

All machines must be inspected regularly for mechanical damage.

The user is responsible for changing parts in accordance with the lifetime of parts, in particular:

bearings, grease and lubrication of shaft sealing.

Maintenance, repairs and replacement on zone 22 motors must only be carried out by qualified specialists.

Connection diagram
Anschlußdiagramm
Anslutningdiagramm
Forbindelsesdiagram
Aansluitdiagram
Connection
Conexión
Collegamento
Схема соединений
Schemat polaczeń

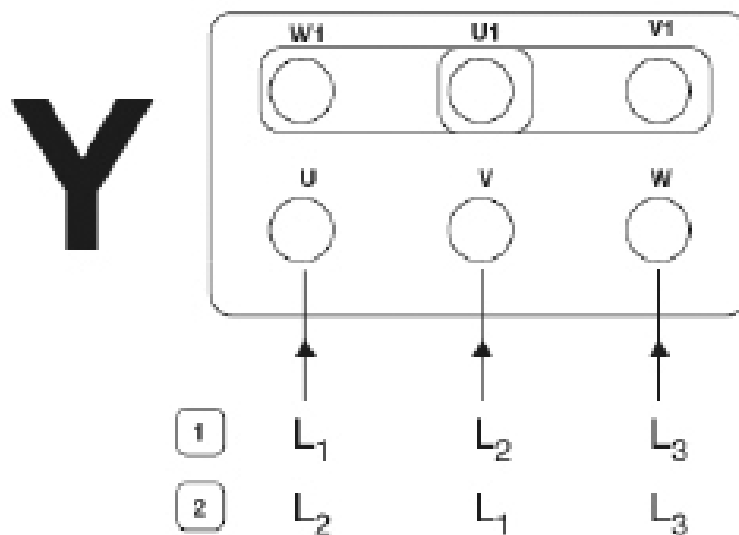
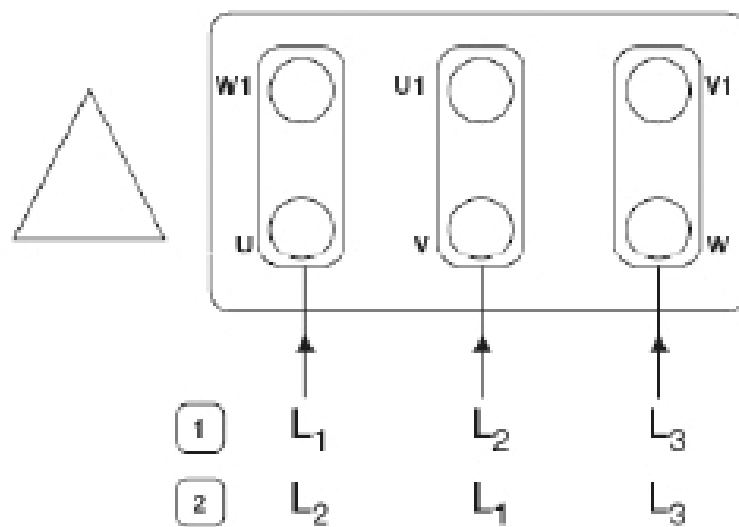



EU Declaration of Conformity

The Manufacturer: Svend Hoyer A/S
Over Hadstenvej 42
DK 8370 Hadsten
Denmark

Hereby declares that

the products: Hoyer Motors, 3-phase induction motors

Aluminum motors MS 56 - 180
HMA* 56 - 180
Cast iron motors Y2E2 80 - 400
HMC* 80 - 400

Hoyer Motors, 1-phase induction motors

Aluminum motors ML 56 - 112
MY 63 - 112

Are in conformity with the following:

Standards: IEC 60034 (All relevant standards on the IEC 60034 series)
Directive: Low Voltage Directive 2014/35/EU

Motor type HMA* and HMC* are also in conformity with:

Standards: IEC 60034-2-1, IEC 60034-30-1
IEC 60079-15, IEC 60079-31
Directive: Eco design for electrical motors 2009/640/EC
ATEX directive 2014/34/EU
Ex II 3D Ex tc IIIB T120°C
Ex II 3G Ex nA IIC T3

Year of CE marking: CE13

Signed by: Thomas Klausen
CEO

Date July 2016



Main office:

Svend Høyer A/S

Over Hadstenvej 42 · DK 8370 Hadsten

Tel. (+45) 86 98 21 11 · Fax (+45) 86 98 17 79

E-mail: svendhoyer@svendhoyer.dk · <http://www.svendhoyer.dk>

Sverige:

Svend Høyer AB

Malmövägen 18 · S-331 42 Värnamo

Tel. (+46) 37 04 77 13 · Fax (+46) 37 01 00 46

E-mail: svendhoyer@svendhoyer.se · <http://www.svendhoyer.se>

Norge:

Svend Høyer AS

Torvet 1 · N-3256 Larvik

Tel. (+47) 33 18 00 11 · Faks: (+47) 33 18 00 13

e-mail: svendhoyer@svendhoyer.no · <http://www.svendhoyer.no>

Deutschland:

Svend Höyer A/S

Over Hadstenvej 42 · DK 8370 Hadsten

Tlf. 0800 1890415 · Fax (+45) 87 61 21 19

E-mail: svendhoyer@svendhoyer.dk · <http://www.svendhoyer.de>

HOYER

Parts list

PAHT C pumps

PAHT C 2/3.2/4/6.3



Parts list | PAHT C pumps

Table of Contents**Contents**

1.	General	51
2.	Spare parts list for PAHT C 2.....	52
2.1	Exploded view for PAHT C 2	53
3.	Spare parts list for PAHT C 3.2-6.3.....	54
3.1	Exploded view for PAHT C 3.2-6.3.....	55

Parts list | PAHT C pumps

1. General

This parts list provides an overview of the content of the various service sets as well as exploded views for both non ATEX and ATEX certified pumps.
ATEX certified pumps are indicated by Ex in the designation.

Non ATEX	ATEX
PAHT C2	PAHT C 2 Ex
PAHT C 3.2	PAHT C 3.2 Ex
PAHT C 4	PAHT C 4 Ex
PAHT C 6.3	PAHT C 6.3 Ex

Parts list | PAHT C pumps
2. Spare parts list for PAHT C 2

Pos.	Qty.	Designation	Material	180B4100 - Screw & Seal set (PAH / PAHT 2-6.3)	180B4572 - Screw & Seal set FFKM (PAHT C 2-6.3)	180B4112 - Cylinder barrel set (PAH 2-6.3)	180B4104 - Cylinder barrel set (PAHT / PAHT C 2-6.3)	180B4101 - Valve plate set (PAH / PAHT 2-6.3)	180B4571 - Valve plate set FFKM (PAHT C 2-6.3)	180B4110 - Piston set (PAH 2)	180B4102 - Piston set (PAH / PAHT / PAHT C 2)	180B4301 - Swash plate set (PAH / PAHT / PAHT C 2)	180Z0235 - Tool set
-	1	Shaft bush, torpedo	-										X
-	1	Press bush	-										X
1	1	Housing	AISI 304 / PEEK										
2	1	Pin	AISI 316	X	X								
5	4	Screw	AISI 316	X	X								
31	1	Swash plate	AISI 431									X	
32	1	Screw	AISI 304									X	
33	1	Washer	AISI 304									X	
34	1	Pin	AISI 316									X	
61	1	Cylinder barrel	AISI 431 / PEEK			X	X						
62	1	Spring	AISI 304							X	X		
65	1	Retainer plate	AISI 431							X	X		
66	5	Piston	AISI 431 / PEEK							X	X		
67	1	Key	AISI 316Ti	X	X								
69	1	Stop	PEEK							X	X		
91	1	Port plate	AISI 304 / PEEK					X	X				
92	1	Valve plate	AISI 431					X	X				
93	5	Back up ring	PTFE	X	X			X	X				
94	5	O-ring	NBR	X	X*			X	X				
121	1	Port flange	AISI 304 / PEEK										
122	1	O-ring	NBR	X	X*								
123	1	O-ring	NBR	X	X*								
124	1	Shaft seal	AISI 304 / NBR	X	X*								
125	1	End cover	AISI 304										
126	1	Pin	AISI 316					X	X				
127	2	Screw	AISI 304	X	X								
130	1	Usit-ring	AISI 304 / NBR	X	X								
136	2	O-ring	NBR	X	X*								
-	1	Service instruction (180R9094)	-	X	X	X	X	X	X	X	X	X	

* FFKM sealing material

Parts list | PAHT C pumps
3. Spare parts list for PAHT C 3.2-6.3

Pos.	Qty.	Designation	Material	180B4100 - Screw & Seal set (PAH / PAHT 2-6.3)	180B4572 - Screw & Seal set (PAHT C 2-6.3)	180B4112 - Cylinder barrel set (PAH 2-6.3)	180B4104 - Cylinder barrel set (PAHT / PAHT C 2-6.3)	180B4101 - Valve plate set (PAH / PAHT 2-6.3)	180B4571 - Valve plate set (PAHT C 2-6.3)	180B4111 - Piston set (PAH / 4-6.3)	180B4103 - Piston set (PAHT / PAHT C 3.2-6.3)	180B4302 - Swash plate set (PAHT / PAHT C 3.2)	180B4303 - Swash plate set (PAH / PAHT / PAHT C 4)	180B4304 - Swash plate set (PAH / PAHT / PAHT C 6.3)	180Z0235 - Tool set
-	1	Shaft bush, torpedo	-												X
-	1	Press bush	-												X
1	1	Housing	AISI 304 / PEEK												
2	1	Pin	AISI 316	X	X										
5	4	Screw	AISI 316	X	X										
31	1	Swash plate	AISI 431									X	X	X	
32	1	Screw	AISI 304									X	X	X	
33	1	Washer	AISI 304									X	X	X	
34	1	Pin	AISI 316									X	X	X	
61	1	Cylinder barrel	AISI 431 / PEEK			X	X								
62	1	Spring	AISI 304							X	X				
63	1	Spring guide	PEEK							X	X				
64	1	Retainer ball	AISI 431							X	X				
65	1	Retainer plate	AISI 431							X	X				
66	5	Piston	AISI 431 / PEEK							X	X				
67	1	Key	AISI 316Ti	X	X										
91	1	Port plate	AISI 304 / PEEK					X	X						
92	1	Valve plate	AISI 431					X	X						
93	5	Back up ring	PTFE	X	X			X	X						
94	5	O-ring	NBR	X	X*			X	X*						
121	1	Port flange	AISI 304 / PEEK												
122	1	O-ring	NBR	X	X*										
123	1	O-ring	NBR	X	X*										
124	1	Shaft seal	AISI 304 / NBR	X	X*										
125	1	End cover	AISI 304												
126	1	Pin	AISI 316					X	X						
127	2	Screw	AISI 304	X	X										
130	1	Usit-ring	AISI 304 / NBR	X	X										
136	2	O-ring	NBR	X	X*										
-	1	Service instruction (180R9094)	-	X	X	X	X	X	X	X	X	X			

* FFKM sealing material

Parts list | PAHT C pumps

3.1 Exploded view for PAHT C 3.2-6.3

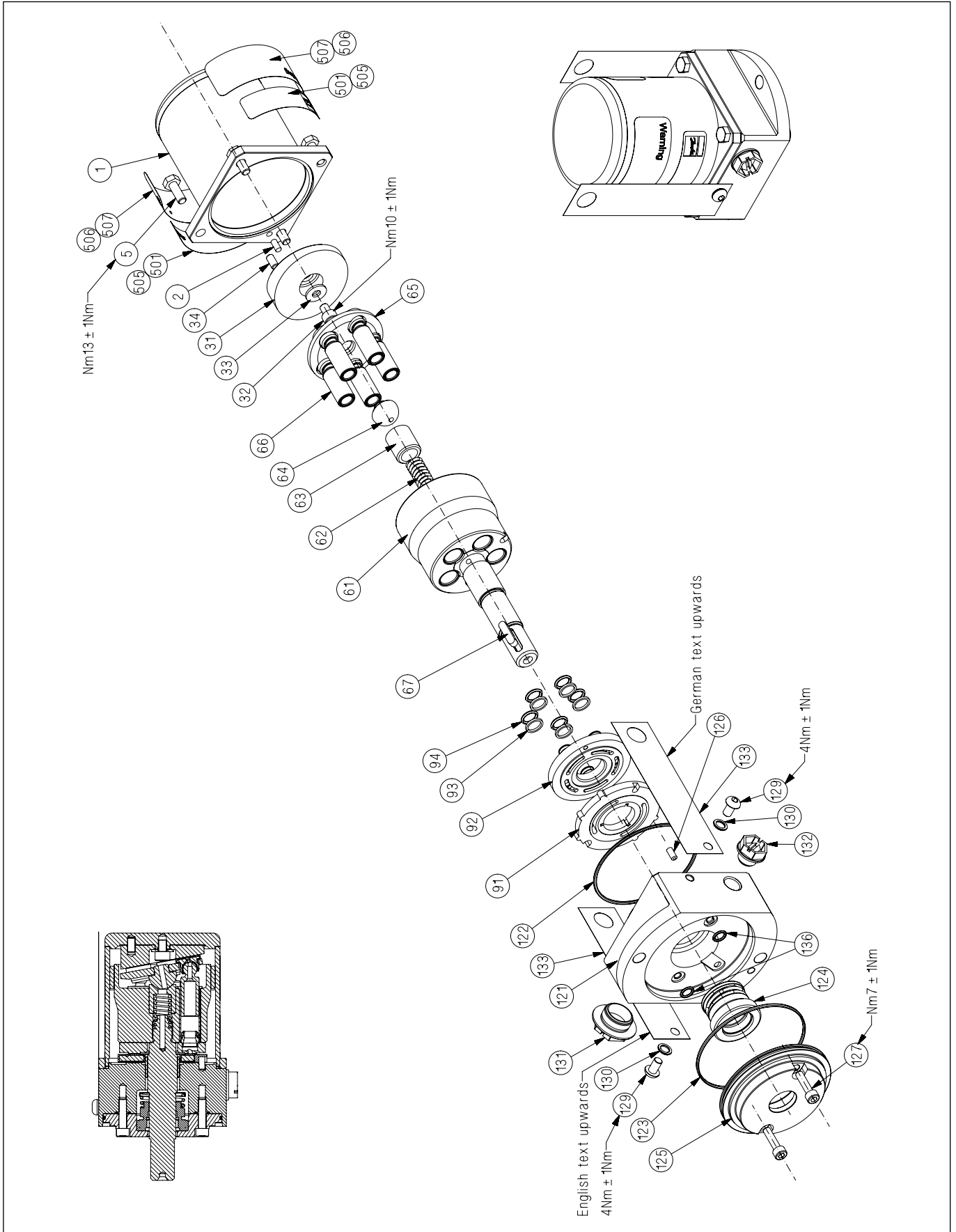

Danfoss A/S
High Pressure Pumps
Nordborgvej 81
DK-6430 Nordborg
Denmark

Guide line.

**PAH / PAHT / PAHT C / PAHT G /
PAHT 674 / PAH F pumps**
Trouble shooting guide



Table of Contents

Table of Contents

	Trouble shooting fish bone chart	59
1.	No flow/no pressure.	60
2.	Reduced flow/reduced pressure	61
3.	High torque on electric motor	62
4.	Noise from pump	63
5.	Noise from installation	64
6.	Typical signs of wear	65
6.1	Valve plate	65
6.2	Port plate	66
6.3	Swash plate	66

Validity

This document is covering the pumps PAH, PAHT PAHT C, PAHT G, PAHT 674 and PAH F for both non ATEX and ATEX certified. PAHT and PAH F pumps are not TEAX certified.

Trouble shooting fish bone chart

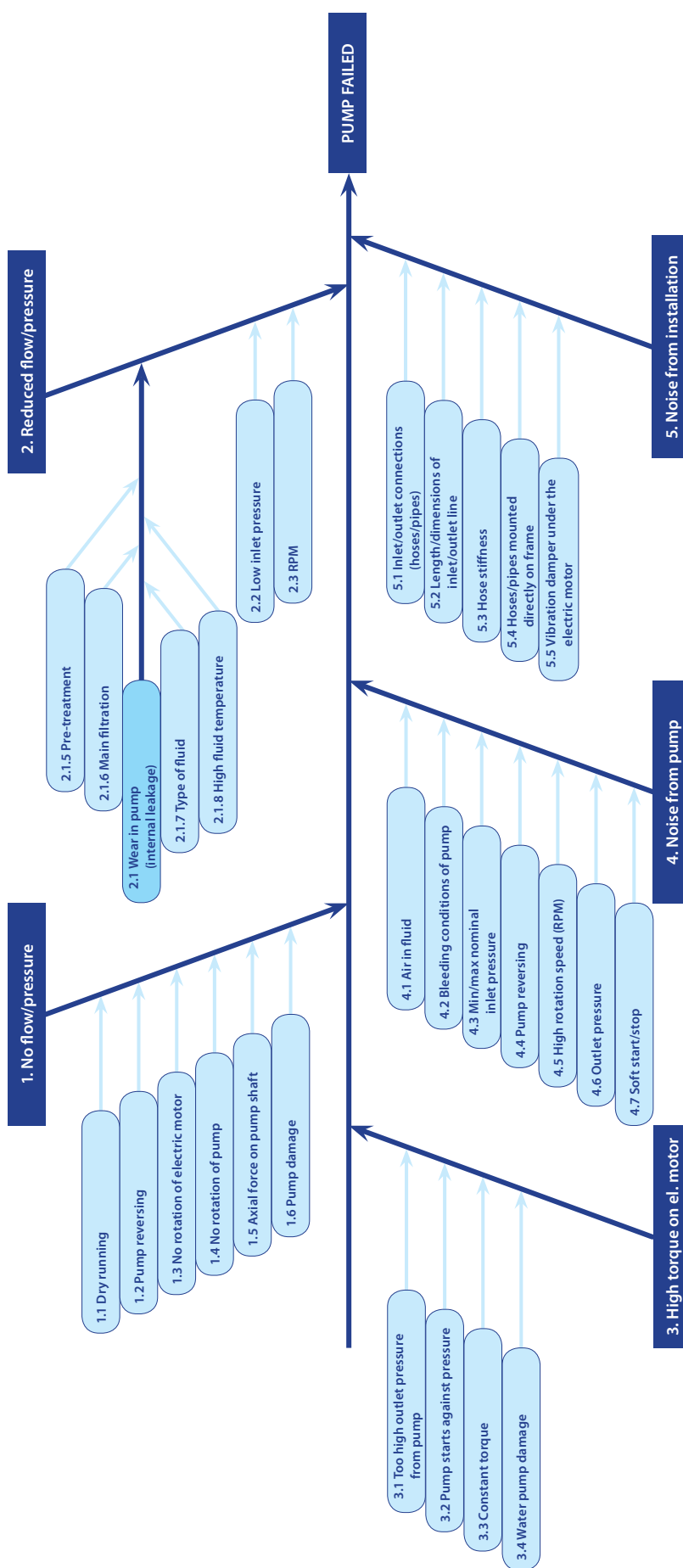

1. No flow/no pressure

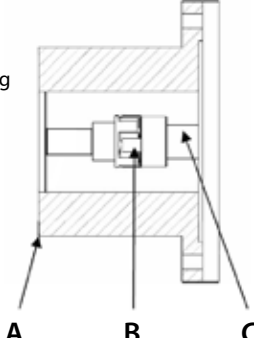
Cause	Remedy	Comments
1.1 Dry running (no water supply to the pump)	If no water comes out of the pump: 1.1.1 Check that inlet valve is open. 1.1.2 Check that booster pump is running.	Mount a low pressure switch in front of the pump and check its set point/ function. The low pressure switch ensures that the pump does not start until the inlet pressure has reached minimum inlet pressure (see Data sheet).
1.2 Pump reversing (electric motor is running the wrong direction, i.e. counter-clockwise)	1.2.1 Change the phase on the electric motor to make it run clockwise. WARNING: - The pump must not run without water for more than a few seconds. - If the pump takes in water from the high-pressure outlet line, it builds up pressure in pump housing and will eventually break down.	Rotation direction for the pump is shown by an arrow on the label on the pump.
1.3 No rotation of electric motor	1.3.1 Check that main switch is switched on. 1.3.2 Check the electricity at the facility. 1.3.3 Ensure that motor relay is switched on. 1.3.4 Ensure that fuse is not blown. 1.3.5 Ensure that booster pump is started. 1.3.6 Check that the monitor switches are working correctly. 1.3.7 Disconnect pump from electric motor and check that the motor is capable of running with no load.	If motor-type relay or the electrical fuse is blown, check that electric motor is sized correctly.
1.4 No rotation of pump	1.4.1 Ensure that coupling between electric motor and pump is connected. 1.4.2 Check if coupling is damaged. 1.4.3 Check that electric motor is sized correctly. 1.4.4 Check that the electrical installation is correctly sized. 1.4.5 Contact Danfoss Sales office for guidelines in how to troubleshoot internal pump parts.	
1.5 Axial load on pump shaft (may cause high internal leakage) Only applying to PAH 2-12.5 PAHT 2-308 PAH F 20-40 PAHT C 2-308 PAHT G 2-308	1.5.1 Ensure that the air gap between the two coupling parts is min 5 mm. It should always be possible to move the plastic part on the coupling at least 3 mm.	To ensure easy mounting of the flexible coupling without using tools, the tolerances must be dimensioned accordingly. WARNING: Any axial and/or radial loads on the shaft must be avoided. Any axial or radial load will cause breakdown. A - Bell housing B - Flexible coupling C - Motor shaft 
1.6 Pump damage (the internal parts may be damaged)	1.6.1 Contact Danfoss sales office for guidelines in how to troubleshoot internal pump parts.	Instructions on internal elements are available on www.danfoss.high-pressurepumps.com

2. Reduced flow/reduced pressure

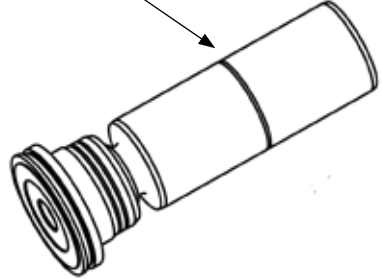
Cause	Remedy	Comments
<p>2.1 Wear on pump Large internal leakage due to:</p>	<p>2.1.1 Dismantle the pump. 2.1.2 Check valve plate. Valve plate has marks/scratches on the surface facing the port plate. Minor wear on valve plate can cause large internal leakage. See Index 6.1. 2.1.3 Check port plate. Port plate has marks/scratches on the surface facing the valve plate. Minor wear on port plate can cause large internal leakage. See Index 6.2. 2.1.4 Check cylinder barrel. Liners in cylinder barrel may be scratched or worn. Insert a piston in the liner and check the fit. If there is any space (clearance) between liner and piston, liner or piston is worn. 2.1.5 Pre-treatment: Analyse fluid for content of particles. - Check that filters are OK and working correctly. 2.1.6 Main filtration: Check that the correct filter type is used (particles in fluid must not exceed 10 µm). Danfoss High Pressure Pumps supplies filters, please contact the sales office. 2.1.7 Fluid type: The PAH/PAH F (tapwater) and PAHT/PAHT G (ultra pure water) pumps are designed for water operation; for any other fluid, please contact Danfoss High Pressure Pumps sales office for further help. 2.1.8 High fluid temperature: If fluid temperature is above 50°C, stop the pump immediately. - Check internal parts (see above).</p>	<p>Typical signs of wear: Polished surface all over the swash plate. Normally, only half of the swash plate = the pressure side is polished. See index 6.3. If the ring is missing, the piston is very worn.</p>  <p>The filters can be bypassed, even if they are correctly mounted. Some filters can create channelling where particles can pass through the filter in tunnels. String wounded filters are typically channelling filters. A string wound filter may have a filtration efficiency of only 50%, which will cause internal wear and must always be followed by a main filter.</p> <p>Insufficient filtration means that too many or too large hard particles can pass the main filter because it is damaged, bypassed or simply too poor. Filtration efficiency must be 99.98% (Beta = 5000) at 10 µm to prevent abnormal wear of the pump.</p> <p>Temperature > 50°C will cause wear on internal pump parts. Mount a temperature switch and check its set point / function. The temperature switch will ensure that the pump stops at fluid temperatures > 50°C.</p>
<p>2.2 Low inlet pressure</p>	<p>2.2.1 Check that booster pump supplies the right pressure/flow. 2.2.2 Check if filters require replacement.</p>	<p>If the pressure drop across the filters is too high, the booster pump does not deliver sufficient flow/pressure. No pressure or low pressure results in cavitation and insufficient internal lubrication causing wear on internal pump parts.</p> <p>Mount a low-pressure switch in front of the pump and check its set point/ function. The low-pressure switch ensures that the pump does not start until the inlet pressure has reached 1 bar.</p>
<p>2.3 Rotation speed (rpm)</p>	<p>2.3.1 If VFD-operated, check frequency. 2.3.2 Check that rotation speed of the electric motor is as stated on name plate on electric motor. Check that the motor rotor winding is not damaged.</p>	<p>Speeds below minimum limit (see Data sheet) result in insufficient internal lubrication causing wear on the internal pump parts.</p>

3. High torque on electric motor

Cause	Remedy	Comments
3.1 Too high outlet pressure from pump	3.1.1 Check for blocked nozzles or a faulty adjusted relief valve.	Pressure changes due to flow restrictions. This will also cause high motor torque.
3.2 Pump starts against pressure	3.2.1 Check that electric motor is correctly sized. 3.2.2 Check internal parts (see item 2.1). 3.2.3 Systems with more than one electric motor installed: Start motors simultaneously.	Pumps run in parallel with cascade start, may switch off the motor relay due to too high torque caused by high outlet pressure.
3.3 Constant torque	3.3.1 Please contact Danfoss High Pressure Pumps sales office.	If the electric motor is too small for the pump, it cannot provide sufficient torque.
3.4 Water pump damage	3.4.1 Dismantle pump and check for wear.	Too heavy damage in the pump will increase friction causing a high torque (see item 6, Typical signs of wear).

4. Noise from pump

Cause	Remedy	Comments
4.1 Air in fluid	4.1.1 Ensure that the entire inlet line is bled before starting up the system. 4.1.2 Ensure that air cannot enter into the inlet line.	Small air bubbles will accumulate and create large bubbles causing internal cavitation and thus making the pump very noisy. WARNING: The pump can only run few minutes with air in the fluid without being damaged.
4.2 Bleeding conditions of pump	4.2.1 Follow the instructions "Initial start-up" supplied with the new pump. 4.2.2 Ensure that the pump is completely bled before start-up.	The pump and the inlet line must be completely bled before start-up, otherwise the pump will cavitate and make high noise. WARNING: The pump can only run few minutes with air in the fluid without being damaged.
4.3 Min/max nominal inlet pressure	4.3.1 Ensure that inlet pressure is within the limits specified in the Data sheet. 4.3.2 Check the pump for internal damage.	Too high inlet pressure causes too high pressure inside the pump damaging the pistons and eventually the pump. Inlet pressure below min. limit causes cavitation and insufficient internal lubrication resulting in wear on internal pump parts. Mount a low-pressure switch in front of the pump and check its set point/ function. The low-pressure switch will ensure that the pump does not start until the minimum inlet pressure has been reached.
4.4 Pump reversing	4.4.1 Dismantle pump and check if anything is broken or worn (See "1. No flow", item 1.2 Pump reversing"). WARNING: The pump must not run without water for more than a few seconds. If the pump takes in water from the high-pressure outlet line, it builds up pressure and will eventually be damaged.	If pump rotates in wrong direction, it will take in water from the high-pressure outlet line. Pressure will be built up inside the pump and it will eventually be damaged.
4.5 High rotation speed (rpm)	4.5.1 If electric motor rpm is too high, dismantle pump and check for damage. 4.5.2 If the rpm is within the specified range of the pump data sheet and abnormal noise remains, dismantle pump and check for damage.	Higher rpm than specified in the pump data sheet results in wear of the pistons, i.e. pistons may be damaged. High rpm will also increase pressure pulsations from the pump, and the noise level will increase. If rpm is changed, noise frequency will also change.
4.6 Outlet pressure	4.6.1 If outlet pressure is too low, check set point of outlet pressure valve. 4.6.2 If outlet pressure is lower than mentioned in the pump data sheet, please contact Danfoss High Pressure Pumps technical support. 4.6.3 If outlet pressure has exceeded its maximum, check set point of outlet pressure valve. 4.6.4 Check internal parts for wear/damage.	At too low outlet pressure, the pump will create higher pressure pulsations and thus make noise. Too low pressure also causes insufficient internal lubrication and wear on internal parts. Pump may eventually be damaged. Too high outlet pressure may damage the pump.
4.7 Soft start/stop	4.7.1 Check if noise is normal when the pump is running at operation speed. 4.7.2 If noise is abnormal at operation speed, check internal parts (see above).	Noise frequency changes during soft start-up/ stop.

5. Noise from installation

Cause	Remedy	Comments
5.1 Inlet/outlet connections (hoses/pipes)	5.1.1 Use flexible hoses at inlet/outlet connections. 5.1.2 Mount the connections to the frame by a vibration dampener mounting plate.	Non-flexible connections mounted directly on the frame will cause even small pressure pulsations from pump and create vibrations in the system/plant.
5.2 Length/dimension of inlet/outlet line	5.2.1 Increase pipe diameter and/or reduce the number of bends.	Too small pipes or too many bends may create too fast flow/turbulence through the pipes and thus increase the noise level.
5.3 Hose stiffness	5.3.1 Use a more flexible hose.	Too stiff hoses cannot dampen the small pressure pulsations from the pump, and subsequently vibrations occur in the system/plant.
5.4 Hoses/pipes mounted directly on frame	5.4.1 Mount the connections to the frame by a vibration dampener mounting plate.	If the hoses are mounted directly on the frame, the small pressure pulsations from the pump can be transferred to the frame and the rest of the system/plant.
5.5 Vibration dampener under the electric motor	5.5.1 Mount a vibration dampener below the motor/pump.	When no dampener is installed below the electric motor, vibrations from the motor and pump may be transferred to the frame and the rest of the system/plant.

6. Typical signs of wear 6.1 Valve plate

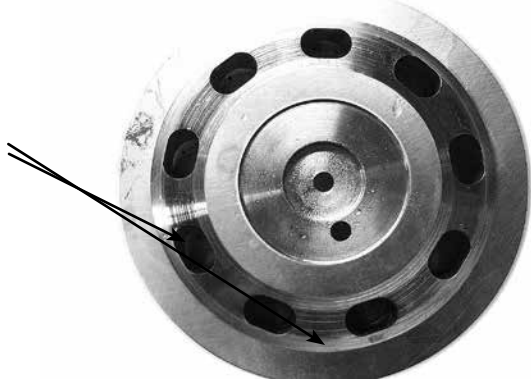
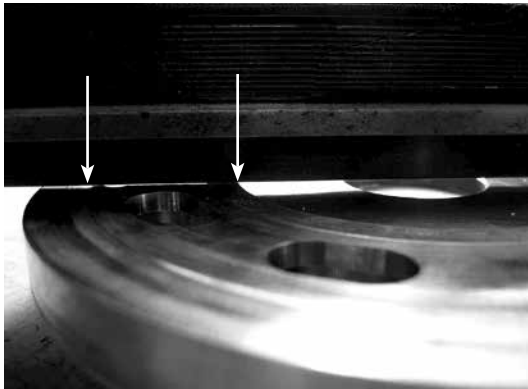
<p>Picture 1</p> 	<p>A normally worn valve plate has no marks/scratches but only a slightly polished surface.</p> <p>No scratches or marks should be felt. The surface must be flat and level.</p>
<p>Picture 2</p> <p>Scratches</p> 	<p>A worn valve plate has scratches, and/or a polished surface. Even small scratches will give a loss of flow.</p>
<p>Picture 3</p> 	<p>A good way to identify a worn valve plate is to hold a straight knife edge over the valve plate. When holding it up to the light, it will be possible to see any space between the knife edge and the valve plate. See picture 3.</p> <p>If any light can be seen between the two arrows on the picture, the valve plate is worn.</p> <p>If any scratches or marks can be felt by running a fingernail over the surface, the valve plate is worn.</p> <p>The valve plate on picture 3 is highly damaged.</p>

6.2 Port plate

Picture 1		<p>If the port plate has scratches, level differences or both between the arrows, the port plate must be replaced.</p> <p>Even small scratches or wear will cause loss of flow.</p> <p>To check: See item 6.1, picture 3</p>
-----------	--	--

6.3 Swash plate

Picture 1		<p>If the swash plate is polished 360°, it is an indication of insufficient filtration.</p> <p>The surface of the swash plate must be plane and even at same level all over. To check this, please see item 6.1, picture 3.</p> <p>If the surface has any marks/scratches, it is worn/damaged and a new one is required.</p> <p>Please contact Danfoss High Pressure Pumps sales office for further information.</p>
-----------	--	--

Danfoss A/S
High Pressure Pump
Nordborgvej 81,
DK-6430 Nordborg
Denmark

ENGINEERING
TOMORROW

Danfoss

Service guide.

Right and wrong

Trouble shooting guide for water hydraulic systems

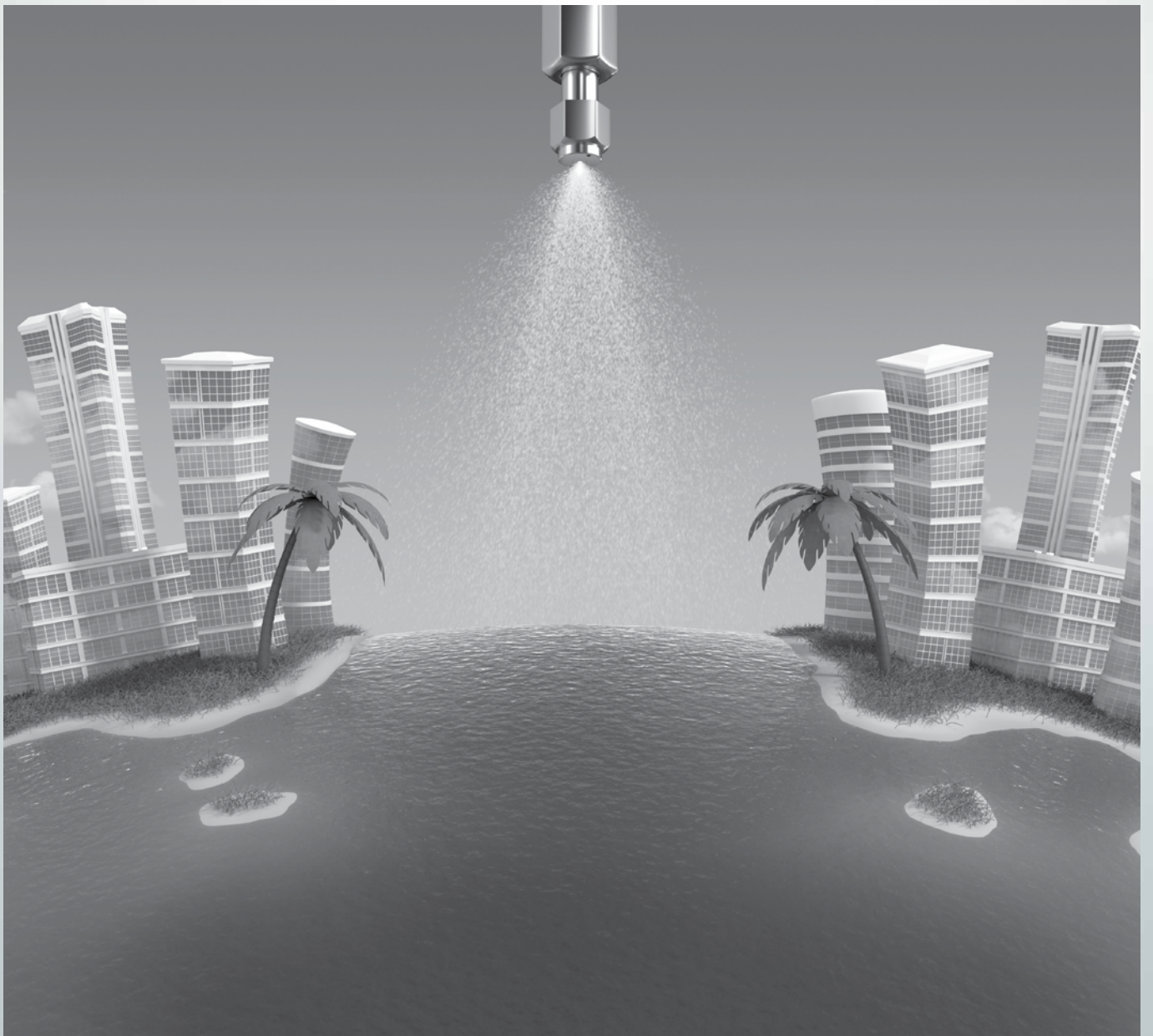

Design

1. Choice of material

- Rubber
- Plastic
- Stainless steel

Always use system components made of corrosion proof materials

- Iron
- Copper
- Brass
- Aluminium

Non-corrosion proof materials may cause damage

2. Choice of filter

< 10 µm abs.

Install a 10 micron absolute filter with pressure switch

> 10 µm

Return filter with bypass valve and poorer filterability than 10 µm will damage the system

3. Filter location

Locate the return filter in the return line immediately before the tank

Placing the return filter upstream of the final load may damage the pump

4. Pump location

Pump always to be placed below water surface level

Pump location above water surface level will cause damage

5. Suction conditions

System to be dimensioned to provide a suction pressure of the pump inlet of max. 0.1 bar vacuum

Poor suction conditions will cause malfunction and damage the pump

6. Pressure Relief valve

Pressure relief valve to be mounted vertically or with vertical outlet and connected to return hose or tank

Coupling the pressure relief valve outlet directly to the pump inlet may damage the pump

7. Water supply

System to be filled via filter

Filling system with unfiltered water causes damage

Installation

8. Impurities

Prior to installation, burrs and chips and other impurities must be removed from pipes and hoses, eg with a felt plug

Chips or other impurities in the system may cause damage

11. Assembly of coupling

The coupling must be easy and simple to assemble (see product instruction)

Never use force when assembling the coupling parts, as this will damage the motor/pump

9. Sealing

Fittings in screwed components to be sealed with O-rings or bonded seals

Using teflon tape or packing yarn in joints may cause damage

12. Coupling

Ensure always to have 3 mm distance between coupling flanges

Insufficient distance and/or misalignment between the coupling flanges will damage the pump

10. Grease

Correctly limited quantities of grease prevent seizing

Too much grease may develop biofilm causing operational failures

13. Water supply

Fill system with water before starting to ensure lubrication and cooling

Starting without water will cause damage

Wiring

14.

Level indicator

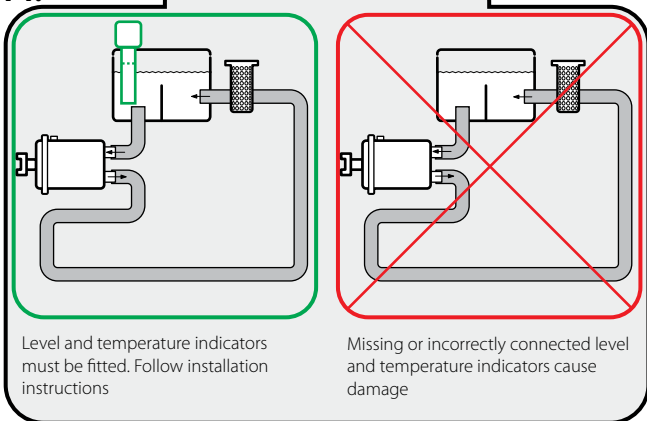

15.

Rotation direction

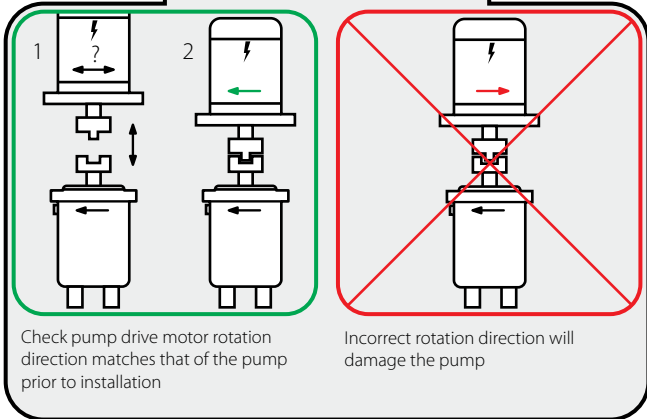

16.

Bleeding

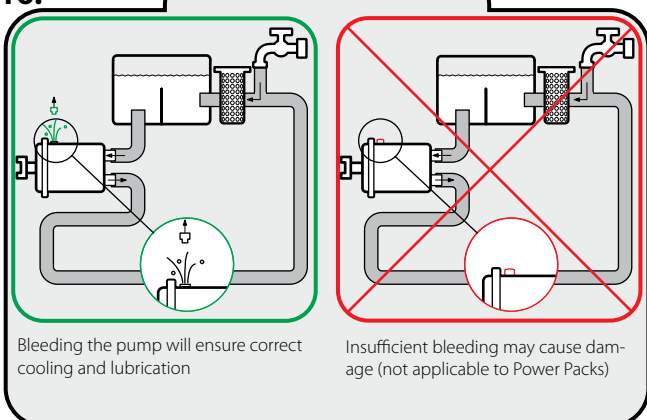

Starting procedure

Cleaning procedure

1. Fill cold water into the system via the return filter and bleed the pump (Power Packs PPH 4 - 6.3 - 10 and 12.5 are self-bleeding)
2. Start and bleed the system -without pressure by opening the bypass valve
3. Add the cleaning agent to give 3% agent/water solution
4. Run the system for 60 min. and activate all components as often as possible to ensure effective flushing with the cleaning agent
5. Empty the system of the cleaning agent solution

Flushing procedure

6. Fill cold water through the return filter and bleed the pump (Power Packs PPH 4 - 6.3 - 10 and 12.5 are self-bleeding)
7. Run the system for 30 min. and activate all components as often as possible
8. Empty the system of the water
9. Alternatively the system may be flushed by running the unit without the return hose while continuously filling up water. The flushing should continue until there is no trace of cleaning agent in the return water
10. Change the return filter element, fill cold water through the return filter and bleed the pump during start up
11. The system is now ready for operation

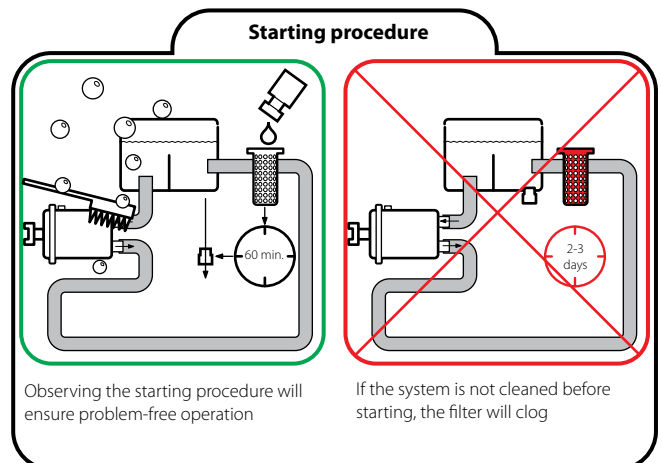

Trouble shooting

Open ended water systems

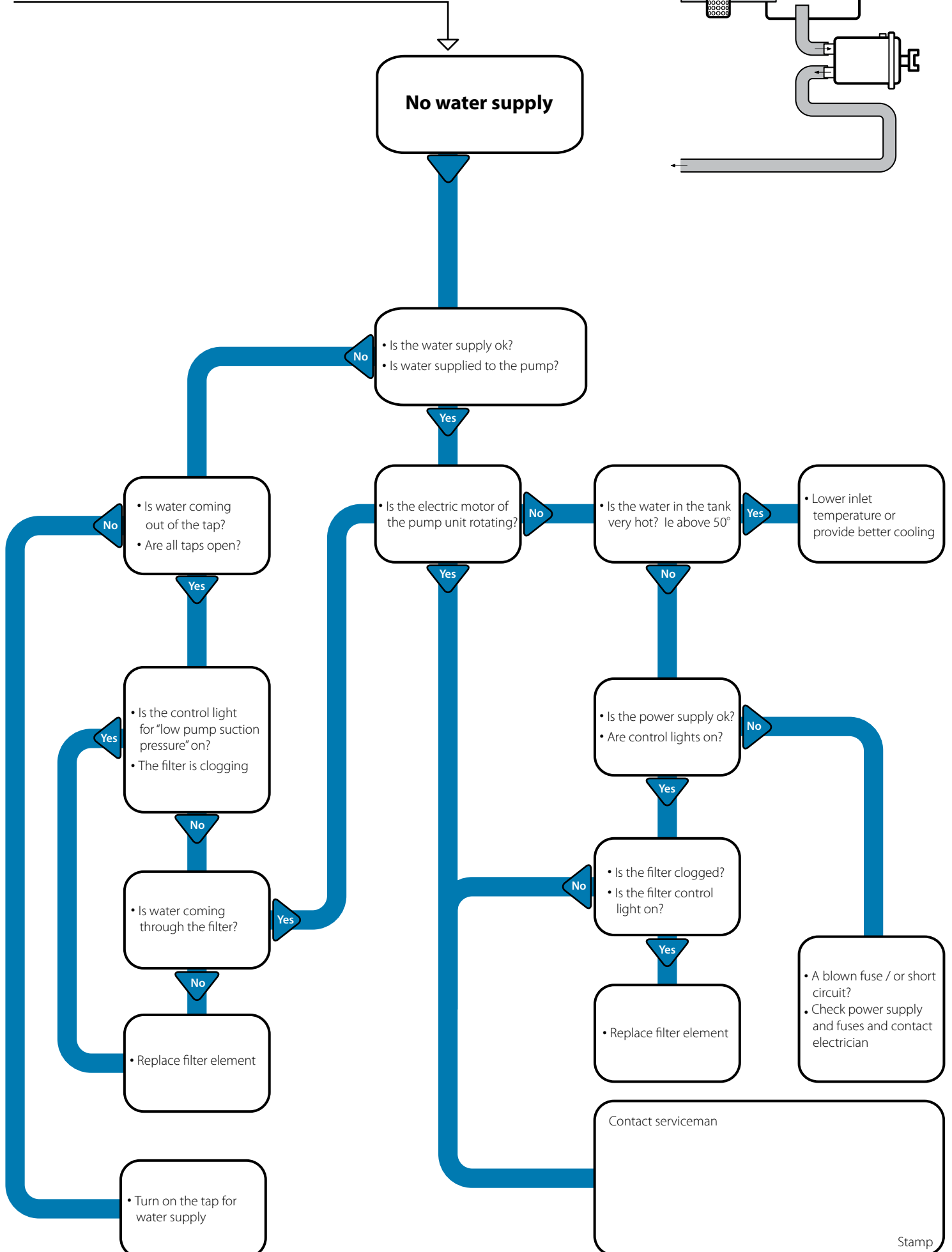
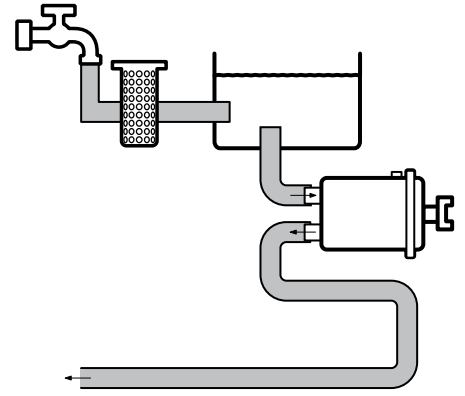

Trouble shooting

Closed water systems

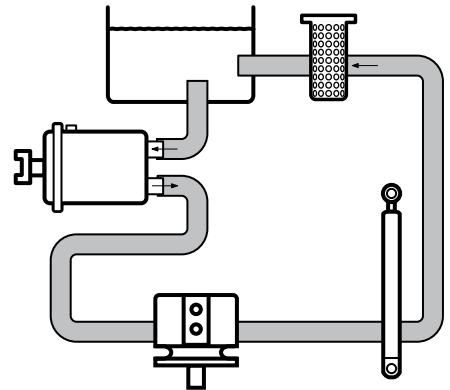

The system does not work

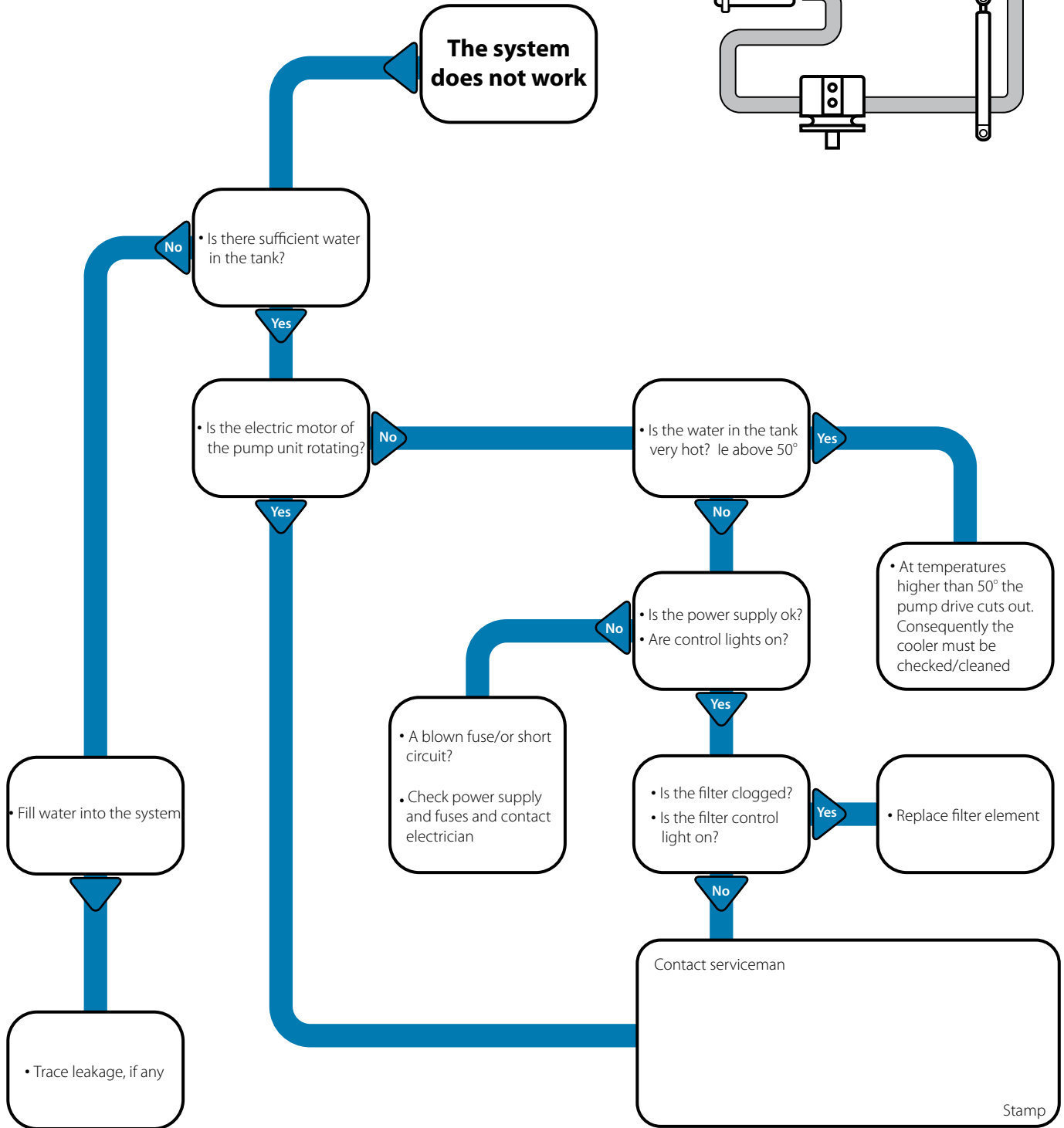

ENGINEERING
TOMORROW



Danfoss A/S

High Pressure Pumps • danfoss.com • +45 7488 2222 • highpressurepumps@danfoss.com

Any information, including, but not limited to information on selection of product, its application or use, product design, weight, dimensions, capacity or any other technical data in product manuals, catalogues descriptions, advertisements, etc. and whether made available in writing, orally, electronically, online or via download, shall be considered informative, and is only binding if and to the extent, explicit reference is made in a quotation or order confirmation. Danfoss cannot accept any responsibility for possible errors in catalogues, brochures, videos and other material. Danfoss reserves the right to alter its products without notice. This also applies to products ordered but not delivered provided that such alterations can be made without changes to form, fit or function of the product.

All trademarks in this material are property of Danfoss A/S or Danfoss group companies. Danfoss and the Danfoss logo are trademarks of Danfoss A/S. All rights reserved.