

Data Sheet

Float valve
Type **SV 1** and **SV 3**

For industrial refrigeration liquid level regulation



Several float valves are available for Industrial refrigeration liquid level control in the product group "Liquid level regulating valves", such as HFI and SV series. The SV series contains the following types: SV 1, SV 3, SV 4, SV 5 and SV 6, some of which can be delivered as dedicated "E" versions for hydrocarbon application.

The SV 1 and SV 3 can be used separately as a modulating liquid level regulator in refrigerating, freezing and air conditioning systems for ammonia or fluorinated refrigerants. However, in most cases, the SV is used as a float pilot valve for the main expansion valve type PMFH.

The SV 1 and SV 3 are used as liquid level regulators in either low pressure applications or in high pressure applications. Adaptation to the specific application is done by the orientation of the valve and thereby the float functions

Portfolio overview

The SV 1 and SV 3 can be used separately as a modulating liquid level regulator in refrigerating, freezing and air conditioning systems for ammonia or fluorinated refrigerants.

However, in most cases, the SV is used as a float pilot valve for the main expansion valve type PMFH.

Several float valves are available for Industrial refrigeration liquid level control in the product group "Liquid level regulating valves", such as HFI and SV series. The SV series contains the following types: SV 1, SV 3, SV 4, SV 5 and SV 6, some of which can be delivered as dedicated "E" versions for hydrocarbon application.

Figure 1: Float valve SV 1 and SV 3



Table 1: Portfolio overview

| Description | Values |
|--|---|
| Refrigerants | R134a, R22, R401A, R402A, R404A, R407A, R407B, R407C, R407F, R409A, R421A, R502, R507, R717 |
| Application | High Pressure Liquid Level Control System (HP LLRS) Low Pressure Liquid Level Control System (LP LLRS) |
| Design versions | |
| Media temperature range | -50 °C – 65 °C |
| P-band [mm] | 35 mm |
| MWP [bar] | 28 bar |
| K_v value [m³/h] | 0.06 for SV 1 0.14 for SV 3 |
| Rated capacity (kW) | SV1: 25 SV3: 64 (R717 +5/32 °C, T ₁ = 28 °C) |

Applications

SV (L), low-pressure function

SV (L), low-pressure function

SV (L) is used for small, flooded evaporators, where only slight variations in the liquid level can be accepted.

When the liquid level falls, the float pos. (2) moves downwards. This draws the needle pos. (15) away from the orifice and the amount of liquid injected is increased.

The liquid inlet line, which is mounted on the nipple pos. (C), should be dimensioned in such a way *that acceptable liquid velocities and pressure drops are obtained*.

This is particularly important when the liquid is only slightly subcooled, since valve capacity is reduced considerably if flashgas occurs in the liquid ahead of the orifice and wear is strongly increased.

See the suggested dimensions for the liquid line in "Pipe dimensions". Refer section [Dimensions and weights](#)

The flashgas quantity which occurs on expansion is removed through the balance pipe from pos. (D). On refrigeration plant using fluorinated refrigerants, slight subcooling and a large pressure drop can give a flashgas quantity of approx. 50% of the injected liquid quantity. Therefore the pressure drop in this balance pipe must be kept at a minimum, since there will otherwise be a risk that the liquid level in the evaporator will vary to an unacceptable degree as a function of evaporator load the absolute difference between the liquid level of the evaporator and the SV valve will be too large.

See the suggested dimensions for the balance pipe in "Pipe dimensions". Refer section [Dimensions and weights](#)

Figure 2: SV (L), low-pressure function

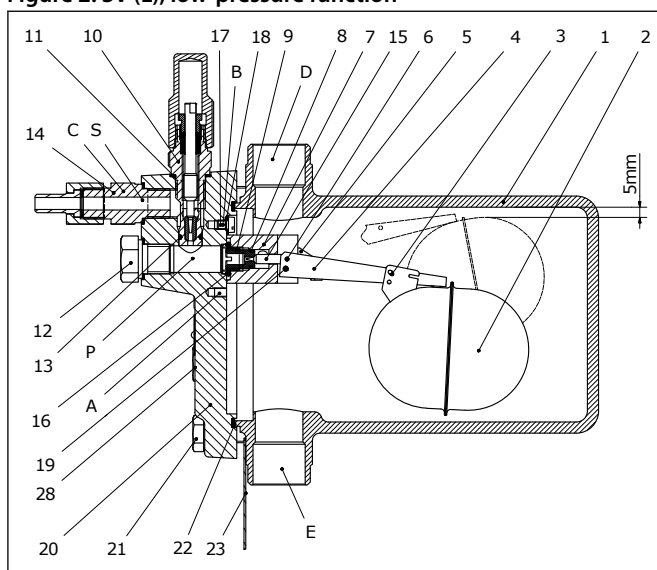

SV (H), high-pressure function

SV (H), high-pressure function

When the liquid level rises, the float pos. (2) moves upwards. This draws the needle pos. (15) away from the orifice and the excess liquid is drawn away.

On refrigeration plant using fluorinated refrigerants slight subcooling and a large pressure drop can, as already mentioned, cause the formation of a large amount of flashgas.

This mixture of liquid and vapour has to pass through the nipple pos. (C) and out into the liquidline.

If the dimensions of the line are too small, a pressure drop will occur which can reduce the capacity of the SV (H) valve considerably. This will mean a risk of inadvertent liquid accumulation in the condenser or receiver.

Float valve, type SV 1 and SV 3

See the suggested dimensions for the liquid line in "Pipe dimensions". Refer section [Dimensions and weights](#)

Figure 3: SV (H), high-pressure function

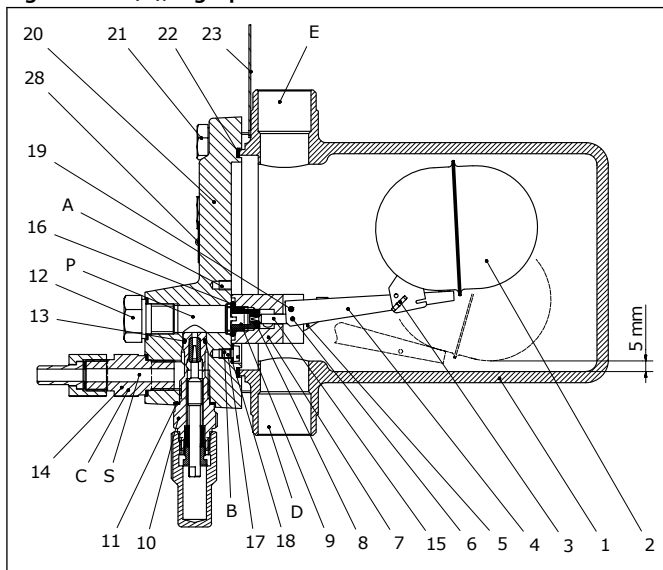

The connection nipple (**C**) can be mounted either in **P** or in **S**

Figure 4: P-connection (= parallel)

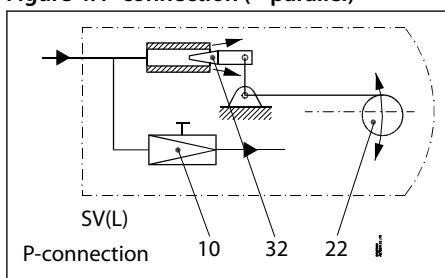

NOTE:

With P-connection an SV with closed float orifice will have a capacity which corresponds to the degree of opening of the adjustable throttle valve 10.

Figure 5: S-connection (= series)

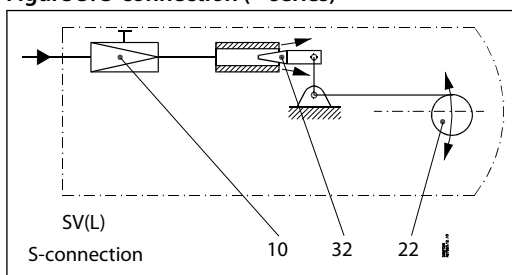

NOTE:

With S-connection the throttle valve 10 will function as a pre-orifice on SV (L) and as a post orifice on SV (H)

SV 1 - 3 used as a high pressure defrost drain float valve

SV 1 - SV 3 can be used as a defrost drain float valve, when one balance pipe is sealed off and the liquid level regulator

is mounted with a special kit (code no. **027B2054**) consisting of:

- Special orifice and orifice needle with a larger k_v -value of $0.28 \text{ m}^3/\text{h}$.
- Gas drain pipe

Float valve, type SV 1 and SV 3

Figure 6: SV 1 - 3 fitted with the special kit (code no. 027B2054)

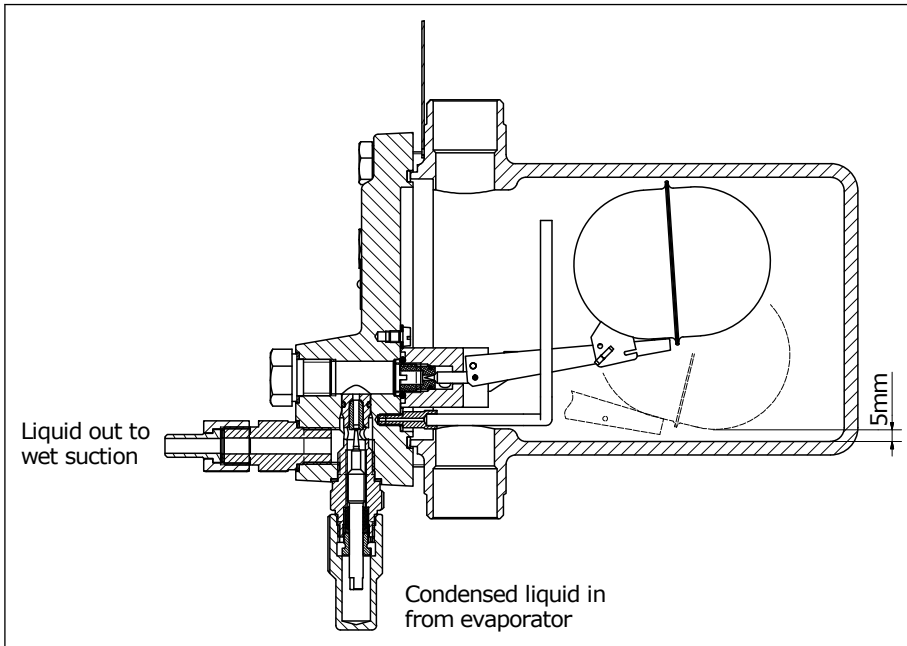
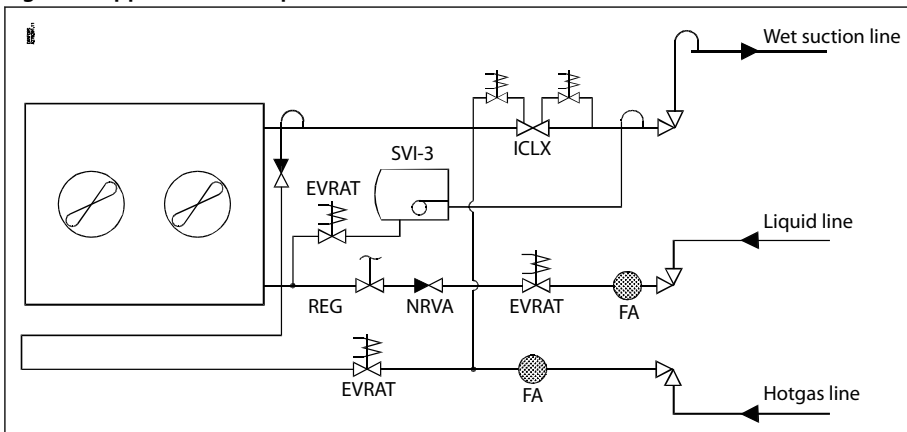

Figure 7: Application example



NOTE:

SV 1 - 3 with special kit mounted as defrost drain float valve on a flooded evaporator with hotgas defrost.

Media

Refrigerants

The SV 1 and SV 3 can be used separately as a modulating liquid level regulator in refrigerating, freezing and air conditioning systems for ammonia or fluorinated refrigerants.

SV float valves are currently authorized by Danfoss for use with several R numbers HCFC, non-flammable HFC, Ammonia, CO₂ and hydrocarbons. New refrigerants are added frequently to the list of Danfoss approved refrigerants and added to the product types.

For an exhaustive and updated list, look up a code number in <https://store.danfoss.com/en/>.

New refrigerants

Danfoss products are continually evaluated for use with new refrigerants depending on market requirements.

When a refrigerant is approved for use by Danfoss, it is added to the relevant portfolio, and the R number of the refrigerant (e.g. R513A) will be added to the technical data of the code number. Therefore, products for specific refrigerants are best checked at store.danfoss.com/en/, or by contacting your local Danfoss representative.

Product specification

Pressure and temperature data

Table 2: Pressure and temperature data

| Description | Values |
|--|--|
| P band | 35 mm |
| Temperature of medium | -50 °C – 65 °C |
| Max. working pressure | PS = 28 bar |
| Max. test pressure | p' = 36 bar |
| k _v value for float orifice | SV 1 = 0.06 m ³ /h SV 3 = 0.14 m ³ /h |

NOTE:

The highest kv value for the built-in throttle valve is 0.18 m³/h. The throttle valve can be used both in parallel and in series with the float orifice.

Material specification

SV with low-pressure function

Figure 8: SV with low-pressure function

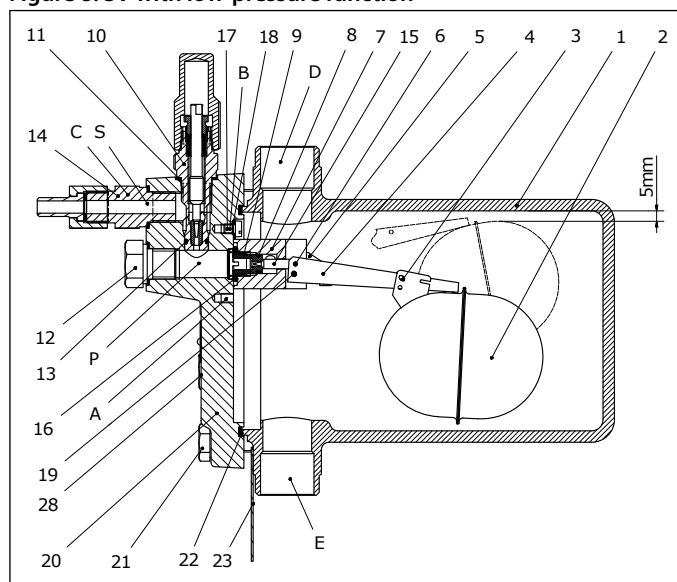

| | |
|----------|---|
| C | Nipple |
| D | Connection for balance pipe |
| P | Parallel connection of pos. C (screw 17 in pos. A) |
| S | Series connection of pos. C (screw 17 in pos. B) |

Table 3: SV with low-pressure function

| No. | Part | Material | DIN / EN |
|-----|--|---|--|
| 1 | Float housing | Stainless steel Low temperature, steel | X5CrNi18-10, DIN 17440 P285QH, EN 10222-4 G20Mn5QT |
| 2 | Float | Stainless steel | |
| 3 | Split pin | Steel | |
| 4 | Float arm | Stainless steel | |
| 5 | Link | Steel | |
| 6 | Pin | Stainless steel | |
| 7 | Valve housing | Steel | |
| 8 | O-ring | Cloroprene (Neoprene) | |
| 9 | Float orifice | Plastic | |
| 10 | Manual regulation unit. Throttle valve | Steel | |
| 11 | Gasket | Non asbestos | |
| 12 | Plug | Steel | |
| 13 | O-ring | Cloroprene (Neoprene) | |
| 14 | Pilot connection (spare part) | Steel | |
| 15 | Orifice needle | Plastic | |

Float valve, type SV 1 and SV 3

| No. | Part | Material | DIN / EN |
|-----|---------------|--|-----------------------------|
| 16 | O-ring | Cloroprene (Neoprene) | |
| 17 | Screw | Steel | |
| 18 | Gasket | Non asbestos | |
| 19 | Pin | Steel | |
| 20 | Cover | Low temperature, cast iron (spherical) | EN-GJS-400-18-LT EN 1563 |
| 21 | Screw | Stainless steel | A2-70 |
| 22 | Gasket | Non asbestos | |
| 23 | Label | Cardboard | |
| 25 | Screw | Steel | |
| 26 | Spring washer | Steel | |
| 28 | Sign | Aluminium | |

SV with high-pressure function

Figure 9: SV with high-pressure function

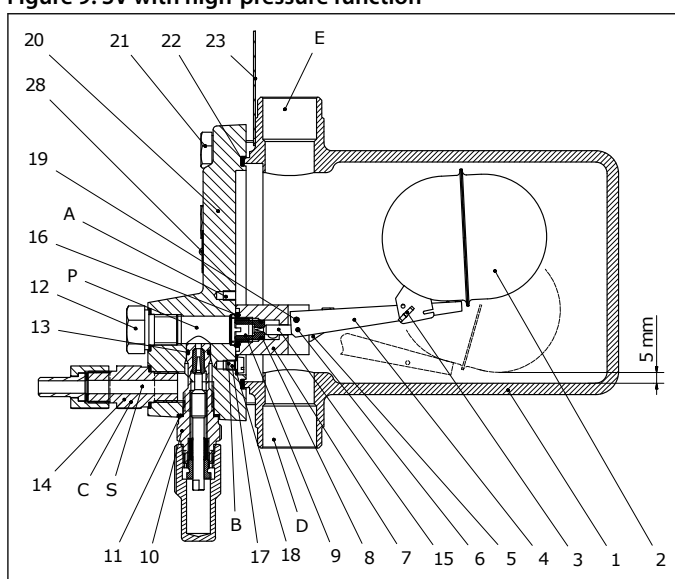

| | |
|----------|---|
| C | Nipple |
| D | Connection for balance pipe |
| P | Parallel connection of pos. C (screw 17 in pos. A) |
| S | Series connection of pos. C (screw 17 in pos. B) |

Table 4: SV with high-pressure function

| No. | Part | Material | DIN / EN |
|-----|--|---|--|
| 1 | Float housing | Stainless steel Low temperature, steel | X5CrNi18-10, DIN 17440 P285QH, EN 10222-4 G20Mn5QT |
| 2 | Float | Stainless steel | |
| 3 | Split pin | Steel | |
| 4 | Float arm | Stainless steel | |
| 5 | Link | Steel | |
| 6 | Pin | Stainless steel | |
| 7 | Valve housing | Steel | |
| 8 | O-ring | Cloroprene (Neoprene) | |
| 9 | Float orifice | Plastic | |
| 10 | Manual regulation unit. Throttle valve | Steel | |
| 11 | Gasket | Non asbestos | |
| 12 | Plug | Steel | |
| 13 | O-ring | Cloroprene (Neoprene) | |
| 14 | Pilot connection (spare part) | Steel | |
| 15 | Orifice needle | Plastic | |
| 16 | O-ring | Cloroprene (Neoprene) | |
| 17 | Screw | Steel | |
| 18 | Gasket | Non asbestos | |
| 19 | Pin | Steel | |

Float valve, type SV 1 and SV 3

| No. | Part | Material | DIN / EN |
|-----|---------------|--|-----------------------------|
| 20 | Cover | Low temperature, cast iron (spherical) | EN-GJS-400-18-LT EN 1563 |
| 21 | Screw | Stainless steel | A2-70 |
| 22 | Gasket | Non asbestos | |
| 23 | Label | cardboard | |
| 25 | Screw | Steel | |
| 26 | Spring washer | Steel | |
| 28 | Sign | Aluminium | |

Connections

Table 5: Pilot connection (weld / solder)



Capacity tables

The values in the capacity tables are based on a subcooling of 4 K just ahead of the SV valve.

If the subcooling is more or less than 4 K, refer to the correction factors provided after the capacity tables.

Table 6: R717 (ammonia)

| | | R717 (NH ₃) | | | | | | | |
|------|---|---|-----|-----|----|----|----|----|----|
| Type | Evaporating temperature t _e °C | Capacity in kW at pressure drop across valve Δp bar | | | | | | | |
| | | 0.8 | 1.2 | 1.6 | 2 | 4 | 8 | 12 | 16 |
| SV 1 | 10 | 9.5 | 11 | 13 | 15 | 20 | 27 | 30 | |
| | 0 | 9.9 | 12 | 14 | 15 | 20 | 27 | 31 | 33 |
| | -10 | 10 | 12 | 14 | 15 | 21 | 27 | 31 | 33 |
| | -20 | 11 | 12 | 14 | 15 | 21 | 27 | 30 | 33 |
| | -30 | 11 | 12 | 14 | 15 | 20 | 26 | 30 | 33 |
| | -40 | 11 | 13 | 14 | 15 | 20 | 26 | 29 | 32 |
| | -50 | 11 | 12 | 13 | 15 | 20 | 26 | 29 | 32 |
| SV 3 | 10 | 25 | 31 | 35 | 39 | 52 | 71 | 77 | |
| | 0 | 26 | 32 | 36 | 40 | 52 | 69 | 78 | 83 |
| | -10 | 26 | 32 | 36 | 40 | 52 | 68 | 77 | 83 |
| | -20 | 26 | 31 | 35 | 39 | 52 | 67 | 76 | 82 |
| | -30 | 25 | 30 | 34 | 38 | 50 | 66 | 75 | 82 |
| | -40 | 24 | 29 | 33 | 36 | 49 | 65 | 73 | 80 |
| | -50 | 23 | 27 | 31 | 35 | 47 | 64 | 71 | 79 |

Table 7: R22

| | | R22 | | | | | | | |
|------|---|---|-----|-----|-----|-----|-----|-----|-----|
| Type | Evaporating temperature t _e °C | Capacity in kW at pressure drop across valve Δp bar | | | | | | | |
| | | 0.8 | 1.2 | 1.6 | 2 | 4 | 8 | 12 | 16 |
| SV 1 | 10 | 2.2 | 2.6 | 3 | 3.2 | 4.2 | 4.8 | 5.7 | 5.7 |
| | 0 | 2.3 | 2.7 | 3.1 | 3.4 | 4.4 | 4.9 | 5.8 | 5.8 |
| | -10 | 2.4 | 2.8 | 3.2 | 3.5 | 4.5 | 5 | 5.8 | 5.9 |
| | -20 | 2.4 | 2.9 | 3.3 | 3.6 | 4.6 | 5 | 5.8 | 5.8 |
| | -30 | 2.5 | 2.9 | 3.3 | 3.6 | 4.5 | 5 | 5.7 | 5.7 |
| | -40 | 2.5 | 2.9 | 3.3 | 3.6 | 4.4 | 4.9 | 5.6 | 5.6 |
| | -50 | 2.6 | 2.9 | 3.3 | 3.5 | 4.3 | 4.8 | 5.4 | 5.4 |

Float valve, type SV 1 and SV 3

| | | R22 | | | | | | | |
|-------------|----------------------------------|---|-----|-----|-----|----|----|----|----|
| Type | Evaporating temperature t_e °C | Capacity in kW at pressure drop across valve Δp bar | | | | | | | |
| | | 0.8 | 1.2 | 1.6 | 2 | 4 | 8 | 12 | 16 |
| SV 3 | 10 | 5.6 | 6.8 | 7.7 | 8.5 | 11 | 13 | 15 | 15 |
| | 0 | 5.8 | 7 | 8 | 8.8 | 11 | 13 | 15 | 15 |
| | -10 | 6 | 7.3 | 8.2 | 9 | 12 | 13 | 15 | 15 |
| | -20 | 6.1 | 7.3 | 8.3 | 8.9 | 11 | 13 | 14 | 15 |
| | -30 | 6.2 | 7.3 | 8.1 | 8.8 | 11 | 12 | 14 | 14 |
| | -40 | 6.1 | 7.1 | 7.9 | 8.5 | 11 | 12 | 14 | 14 |
| | -50 | 5.9 | 6.9 | 7.6 | 8.2 | 11 | 12 | 13 | 14 |

Correction factors

When dimensioning, multiply the evaporator capacity by a correction factor k dependent on the subcooling Δt_{sub} just ahead of the valve. The corrected capacity can then be found in the capacity table.

Table 8: R717 (ammonia)

| | | R717 (NH₃) | | | | | | | | | |
|--------------|------|------------------------------|------|------|------|------|------|------|------|------|------|
| Δt K | 2 | 4 | 10 | 15 | 20 | 25 | 30 | 35 | 40 | 45 | 50 |
| k | 1.01 | 1 | 0.98 | 0.96 | 0.94 | 0.92 | 0.91 | 0.89 | 0.87 | 0.86 | 0.85 |

Table 9: R22

| | | R22 | | | | | | | | | |
|--------------|------|------------|------|------|-----|------|------|------|-----|------|------|
| Δt K | 2 | 4 | 10 | 15 | 20 | 25 | 30 | 35 | 40 | 45 | 50 |
| k | 1.01 | 1 | 0.96 | 0.93 | 0.9 | 0.87 | 0.85 | 0.83 | 0.8 | 0.78 | 0.77 |

Dimensions and weights

Figure 10: SV1 and SV3

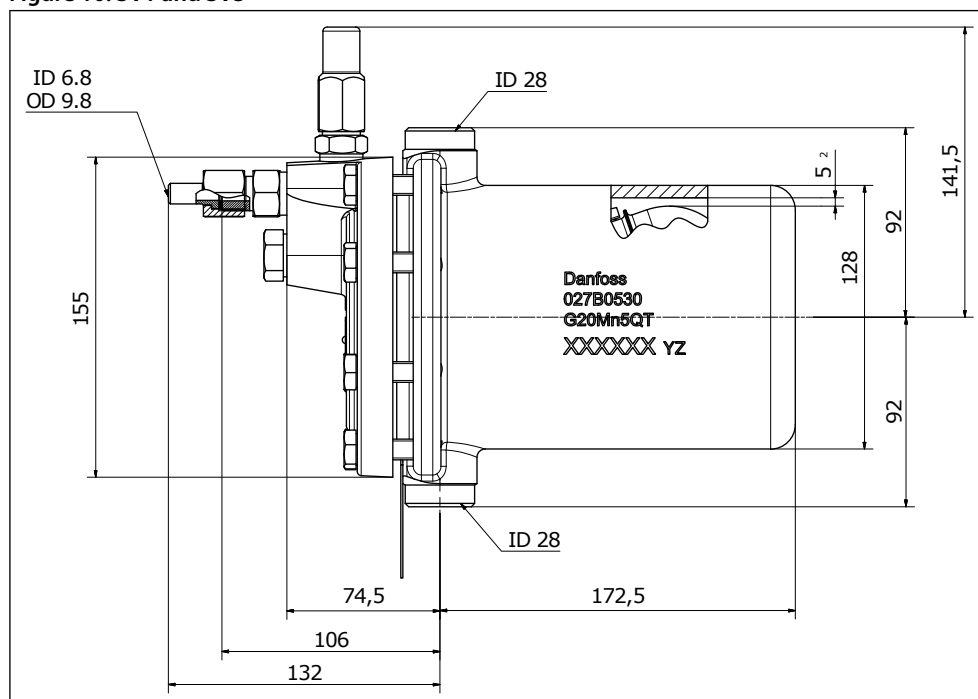

Table 10: SV 1 and SV 3 Dimensions and weights

| Type | Weight |
|-------------|--------|
| SV 1 | 7.5 kg |
| SV 3 | 7.5 kg |

Pipe dimensions

Liquid line

Float valve, type SV 1 and SV 3

The following suggested dimensions for the liquid line, which is connected to the nipple pos. C are based on a maximum velocity in a line with subcooled ammonia of approx. 1 m/s and a maximum velocity in a line with subcooled fluorinated refrigerant of approx. 0.5 m/s.

Table 11: R717 (ammonia)

| Type | Dimensions | |
|------|------------------------|-----------------------|
| | 0.8 bar < Δpsv < 4 bar | 4 bar < Δpsv < 16 bar |
| | Steel tube | Steel tube |
| SV 1 | 3/8 in. | 3/8 in. |
| SV 3 | 3/8 in. | 1/2 in. |

Table 12: R22, R134a, R404A

| Type | Dimensions | | | |
|------|------------------------|-------------|-----------------------|-------------|
| | 0.8 bar < Δpsv < 4 bar | | 4 bar < Δpsv < 16 bar | |
| | Steel tube | Copper tube | Steel tube | Copper tube |
| SV 1 | 3/8 in. | 3/8 in. | 3/8 in. | 1/2 in. |
| SV 3 | 3/8 in. | 5/8 in. | 1/2 in. | 3/4 in. |

Table 13: Upper balance pipe (connect to pos. D on SV (L))

| Type | Dimensions |
|----------|------------|
| SV (L) 1 | 1 in. |
| SV (L) 3 | 1 1/2 in. |

Ordering

Table 14: SV 1 - SV 3 Ordering

| Valve type | Rated capacity in kW | | | | | | Packing format | Qty./pack | Code no. |
|-------------|----------------------|-----|-------|-------|-----|------|----------------|-----------|-----------------|
| | R717 | R22 | R134a | R404A | R12 | R502 | | | |
| SV 1 | 25 | 4.7 | 3.9 | 3.7 | 3.1 | 3.4 | Single pack | 1 pc | 027B2021 |
| SV 3 | 64 | 13 | 10 | 9.7 | 7.9 | 8.8 | Single pack | 1 pc | 027B2023 |

NOTE:

The code nos. stated apply to float valves, types SV 1 and SV 3 incl. \varnothing 6.5 / \varnothing 10 mm weld connection ⁽¹⁾ for the pilot line.

Balance tube connection (liquid/vapour): 1 in. weld / 1 1/8 in. solder.

The rated capacity refers to the valve capacity at evaporating temperature $t_e = +5$ °C, condensing temp. $t_c = +32$ °C and liquid temperature $t_l = +28$ °C.

¹ 3/8 in. flare connection can be supplied under code no. **027B2033**.

Certificates, declarations, and approvals

The list contains all certificates, declarations, and approvals for this product type. Individual code number may have some or all of these approvals, and certain local approvals may not appear on the list.

Some approvals may change over time. You can check the most current status at danfoss.com or contact your local Danfoss representative if you have any questions.

Table 15: Valid Approvals

| File name | Document type | Document topic | Approval authority |
|------------------------------------|---------------------------------|-----------------------|--------------------|
| Д-DK.БЛ08.В.00191_18 | EAC Declaration | Machinery & Equipment | EAC RU |
| 0045 202 1204 Z 00354 19 D 001(00) | Pressure - Safety Certificate | | TÜV |
| Д-DK.РА01.В.72054_20 | EAC Declaration | PED | EAC RU |
| EU 033F0685.AK | EU Declaration | EMCD/PED | Danfoss |
| 033F0691.AD | Manufacturers Declaration | RoHS | Danfoss |
| 033F0473.AD | Manufacturers Declaration | ATEX | Danfoss |
| Д-DK.БЛ08.В.01592 | EAC Declaration | EMC | EAC RU |
| Д-DK.MX24.В.00273 | EAC Declaration | Machinery & Equipment | EAC RU |
| Д-DK.БЛ08.В.01120_19 | EAC Declaration | EMC | EAC RU |
| UL SA7200 | Mechanical - Safety Certificate | | UL |
| UA.10146.D.00069-19 | UA Declaration | PED | LLC CDC EURO-TYSK |
| UA.TR-089.1112.01-19 | Pressure - Safety Certificate | PED | LLC CDC EURO-TYSK |

Table 16: Compliance table

| Type | SV 1 and SV 3 |
|----------------|---------------|
| Classified for | Fluid group I |
| Category | I |

Table 17: Conformity Approvals

| | |
|---|--|
|  | <p>Pressure Equipment Directive (PED) SV 1 and SV 3 are approved in accordance with the European standard specified in the Pressure Equipment Directive and are CE marked. For further details / restrictions - see Installation guide.</p> |
|---|--|

Online support

Danfoss offers a wide range of support along with our products, including digital product information, software, mobile apps, and expert guidance. See the possibilities below.

The Danfoss Product Store



The Danfoss Product Store is your one-stop shop for everything product related—no matter where you are in the world or what area of the cooling industry you work in. Get quick access to essential information like product specs, code numbers, technical documentation, certifications, accessories, and more.

Start browsing at store.danfoss.com.

Find technical documentation



Find the technical documentation you need to get your project up and running. Get direct access to our official collection of data sheets, certificates and declarations, manuals and guides, 3D models and drawings, case stories, brochures, and much more.

Start searching now at www.danfoss.com/en/service-and-support/documentation.

Danfoss Learning



Danfoss Learning is a free online learning platform. It features courses and materials specifically designed to help engineers, installers, service technicians, and wholesalers better understand the products, applications, industry topics, and trends that will help you do your job better.

Create your Danfoss Learning account for free at www.danfoss.com/en/service-and-support/learning.

Get local information and support



Local Danfoss websites are the main sources for help and information about our company and products. Find product availability, get the latest regional news, or connect with a nearby expert—all in your own language.

Find your local Danfoss website here: www.danfoss.com/en/choose-region.

Spare Parts



Get access to the Danfoss spare parts and service kit catalog right from your smartphone. The app contains a wide range of components for air conditioning and refrigeration applications, such as valves, strainers, pressure switches, and sensors.

Download the Spare Parts app for free at www.danfoss.com/en/service-and-support/downloads.

Coolselector®2 - find the best components for you HVAC/R system



Coolselector®2 makes it easy for engineers, consultants, and designers to find and order the best components for refrigeration and air conditioning systems. Run calculations based on your operating conditions and then choose the best setup for your system design.

Download Coolselector®2 for free at coolselector.danfoss.com.

Danfoss A/S

Climate Solutions • danfoss.com • +45 7488 2222

Any information, including, but not limited to information on selection of product, its application or use, product design, weight, dimensions, capacity or any other technical data in product manuals, catalogues descriptions, advertisements, etc. and whether made available in writing, orally, electronically, online or via download, shall be considered informative, and is only binding if and to the extent, explicit reference is made in a quotation or order confirmation. Danfoss cannot accept any responsibility for possible errors in catalogues, brochures, videos and other material. Danfoss reserves the right to alter its products without notice. This also applies to products ordered but not delivered provided that such alterations can be made without changes to form, fit or function of the product.

All trademarks in this material are property of Danfoss A/S or Danfoss group companies. Danfoss and the Danfoss logo are trademarks of Danfoss A/S. All rights reserved.