

Contents

| | |
|---|-----|
| INTRODUCTION | .3 |
| SEAL REPLACEMENT PROCEDURE | |
| Dust seal removal | .3 |
| Shaft seal access | .3 |
| Shaft seal removal | .3 |
| Verify correct bullet for drive shaft | .4 |
| Replacement shaft seal installation | .4 |
| Replacement dust seal installation | .5 |
| INSTALLATION TOOLS | .8 |
| SEAL KIT PART NUMBERS | .11 |

Series 1 shaft seal installation instructions

Introduction

Danfoss heavy duty products are designed to allow field service of the dust seal and shaft seal without disassembling the unit. This document describes the procedure to remove and replace both the dust seal and the shaft seal.

Seal replacement procedure

1. Be sure to read the following instructions completely before beginning work.
2. Removal procedure if a dust seal is already present:
 - a. Dust seal removal procedure:
 - i. Use a punch and hammer to punch a hole in the dust seal. Punch the hole in the middle (radially) of the seal lettering to avoid punching where the seal is supported by the retaining ring.
 - ii. Use a sheet metal screw with the point blunted. Install the screw into the punched hole just far enough to pull the dust seal out of its pocket.
 - iii. Pry the seal out, taking care not to damage the shaft.
 - iv. Discard the dust seal.
 3. Shaft seal access:
 - a. Remove and discard the shaft seal retaining ring (Figure 1).

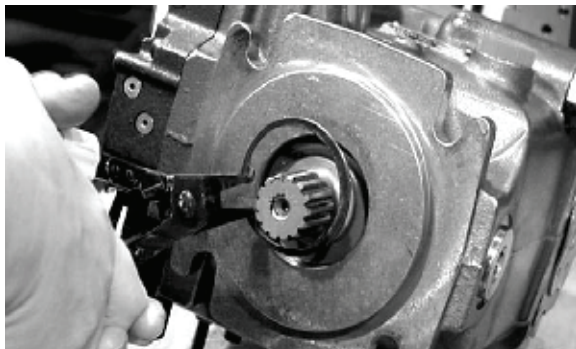

Figure 1. Remove retaining ring

- b. Remove and discard the shaft seal spacer if present.
 - c. The shaft and housing bore should be wiped clean of debris while the current shaft seal is still in place. This will avoid pushing contamination into the pump and maximize the life of the replaced components.

4. If the shaft seal is to be replaced:
 - a. Shaft seal removal procedure:
 - i. Use a drill and a 9/64" drill bit to create a hole in the shaft seal. To avoid drilling too deep into the shaft seal and to help protect the shaft seal diameter if the drill bit wanders, insert the drill bit inside a 5/16" OD hollow tube leaving no more than 0.25" of the drill bit exposed at the end (Figure 2). To reduce drilled material from entering the pump, pack the flutes with grease. Drill the seal until the tube reaches the seal face.

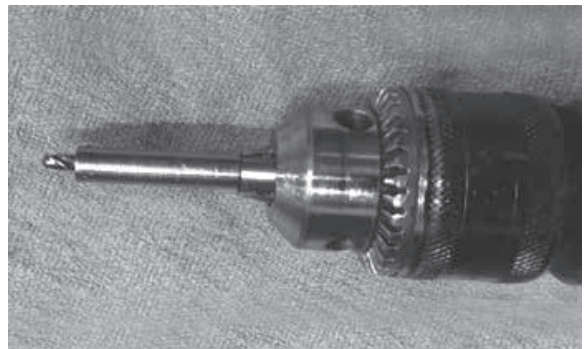

Figure 2. Drill bit guide

- ii. Use a 3 inch #10 sheet metal screw with the point blunted. Install the screw into the hole just far enough to pull the shaft seal out of its pocket (Figures 3, 4 and 5).

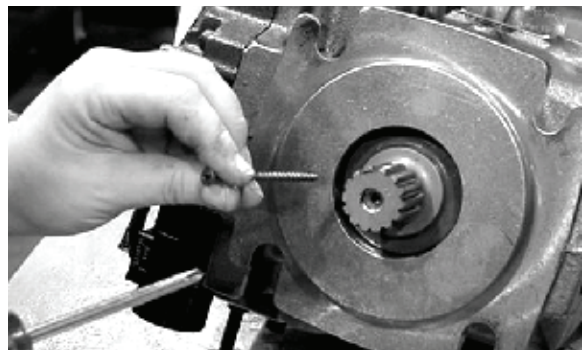

Figure 3. Install screw into hole

Series 1 shaft seal installation instructions

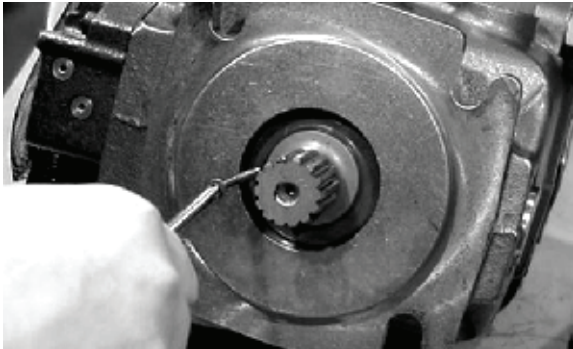

Figure 4. Install screw into hole



Figure 5. Pull seal out of pocket

- iii. Carefully insert the blade of a flat screw driver behind the seal. Pry the seal out, taking care not to damage the shaft (Figure 6).
- iv. Use a magnet tool to remove any metal shavings from drilling the seal. Sometimes the shaft seal internal spring dislodges from the seal during drilling and removal, leaving it behind in the bore. Be sure to remove the shaft seal spring from the bore if this has happened.

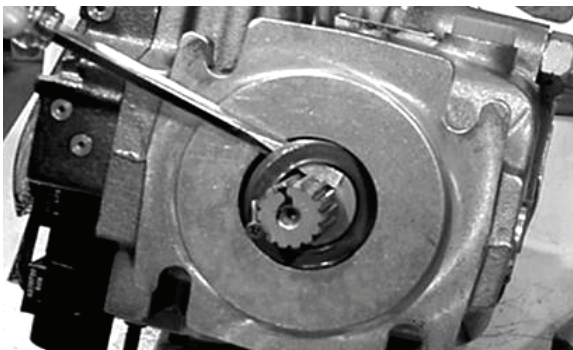

Figure 6. Carefully pry out seal

b. Verify correct bullet for drive shaft

Before assembling the shaft seal, first select and try fitting a bullet to the drive shaft. The bullet and the shaft chamfer must align with each other to leave no gap between the bullet and the shaft. The bullet should pilot on the shaft diameter such that the bullet cannot shift side to side and allow a step between the bullet and the shaft seal diameter.

c. Replacement shaft seal installation procedure:

- i. Wipe clean both the housing bore for the seal and the shaft seal diameter to insure there is no debris that may be pushed into the housing or damage the sealing surface during installation.
- ii. Use seal 6040479-001 for 33/39/46/54/64 Series 1 units and 33/39/46 Series 2 units.
- iii. Apply petroleum jelly to the entire surface of the seal which contacts the housing. Apply petroleum jelly and or clean oil to the leading edge of the seal to lubricate the bullet as the seal is installed. The seal ID is pre-lubed with "Petamo GHY 133 N" grease by the seal supplier.
- iv. Press the new greased shaft seal over a shaft bullet (see Figure 12- 6041669-001). The closed face of the shaft seal is to face the closed end of the bullet.
- v. With the shaft seal on the bullet, insert the bullet over the shaft and into the seal pocket.
- vi. Using the shaft seal installation tool (Figure 7 and 13) and a rubber mallet, gently tap the tool until the tool bottoms on the mounting flange.
- vii. Insert a new shaft seal spacer into the seal pocket. At least 1 spacer must be used when using the dust seal to avoid contact between the dust seal and the shaft seal. A maximum of 2 spacers may be used when replacing a shaft seal. A dab of grease or petroleum jelly may be used to hold the spacer(s) in place so that they do not fall into the retaining ring groove. The purpose of adding another spacer is to position the shaft seal in a new location on the shaft sealing area. If using the spacer, install the spacer between the shaft seal and the retaining ring. See Table 1 for determining how many spacers to use. This depends on whether you have an old or a new drive shaft configuration. New shafts will have a small circular groove machined in the major diameter of the input spline (Figure 8) or across the key way for keyed shafts.
- viii. Insert the retaining ring into the seal pocket.
- ix. Using the shaft seal installation tool (Figure 7 and 13) and a rubber mallet, gently tap the tool until the retaining ring snaps into place in the groove.

Series 1 shaft seal installation instructions

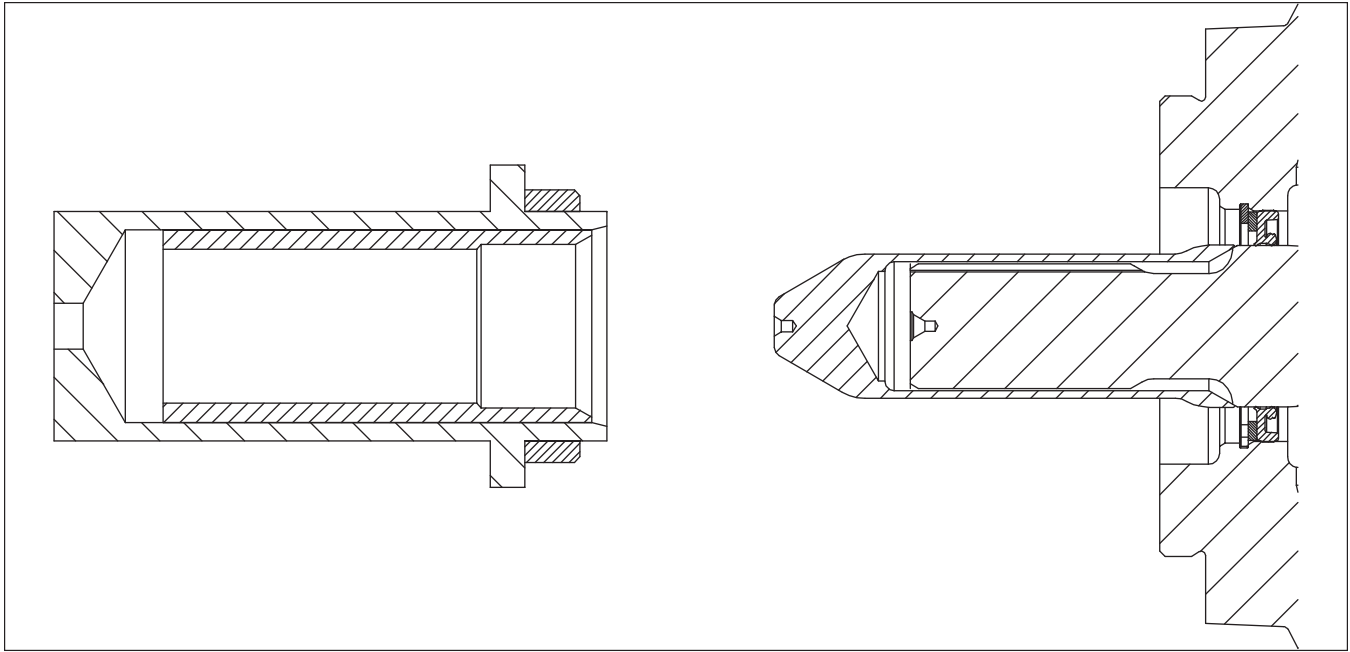

Figure 7. Shaft seal bullet and installation tool

Table 1. Shaft seal spacer selection

Shaft seal replacement with old drive shaft design

| | | Number of spacers old seal | | | |
|------------------------------------|---|----------------------------|-------|-------|-----|
| | | 0 | 1 | 2 | |
| Spacer width (in) | | 0.000 | 0.095 | 0.095 | |
| Number of spacers replacement seal | 0 | 0.000 | No | No | No* |
| | 1 | 0.095 | Yes | No | No* |
| | 1 | 0.150 | No | Yes | No* |
| | 2 | 0.095 | No | No | No* |

Shaft seal replacement with new drive shaft design

| | | Number of spacers old seal | | | |
|------------------------------------|---|----------------------------|-------|-------|-----|
| | | 0 | 1 | 2 | |
| Spacer width (in) | | 0.000 | 0.095 | 0.095 | |
| Number of spacers replacement seal | 0 | 0.000 | No | No | No* |
| | 1 | 0.095 | Yes | No | No* |
| | 2 | 0.095 | No | Yes | No* |

* Danfoss recommends replacing the shaft to extend the life of the new shaft seal .

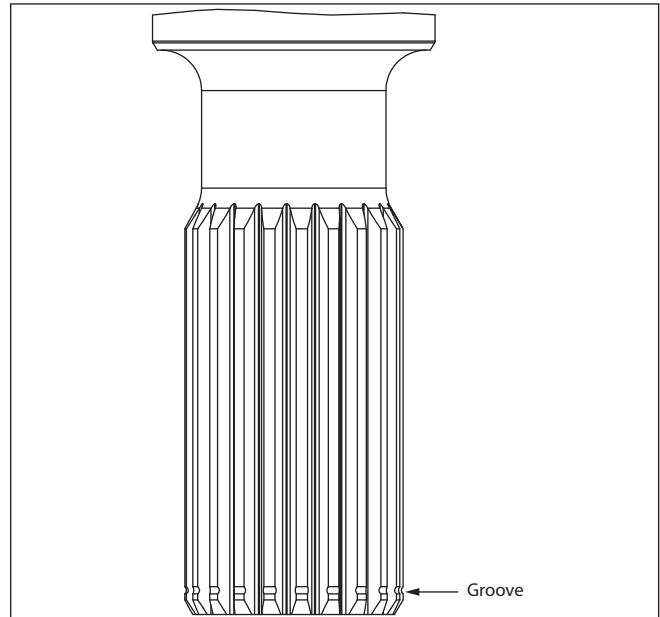

Figure 8. New shaft identification groove

5. New dust seal installation procedure:
 - a. Be sure to wipe away any grease and/or debris from the seal pocket inner diameter which the dust seal will be pressed into and the shaft seal diameter.
 - b. Use the dust seal no go gauge (Figure 14) to check the mounting flange bore for the proper press fit with the dust seal.
 - c. Insert the no go gauge in the bore (Figure 9).
 - i. Pass condition: The gauge will not fit into the bore indicating a reliable press fit between the dust seal and the bore.
 - ii. Fail condition: The gauge will fit into the bore indicating a clearance between the dust seal and the bore. If this happens, then you need to install a new pump for this application.
 - d. Apply petroleum jelly and or clean oil to the leading edge of the seal to lubricate the bullet as the seal is installed. The seal ID is pre-lubed with "Gr-2 Graphite" grease by the seal supplier.
 - e. Press the new greased dust seal over a shaft bullet (see Figure 12 - 6041669-001). The rubber face with lettering of the dust seal is to face the closed end of the bullet.
 - f. With the dust seal on the bullet, insert the bullet over the shaft and into the seal pocket.
 - g. Place the shaft seal installation tool (Figures 10 and 13) over the shaft and into the seal pocket. Using a rubber mallet, gently tap the tool until the dust seal stops off on the retaining ring. Care should be taken not to pound too hard and damage the retaining ring.
 - h. The retaining ring is not accessible when the dust seal is installed.
 - i. Wipe off any excess grease present after installing the dust seal.

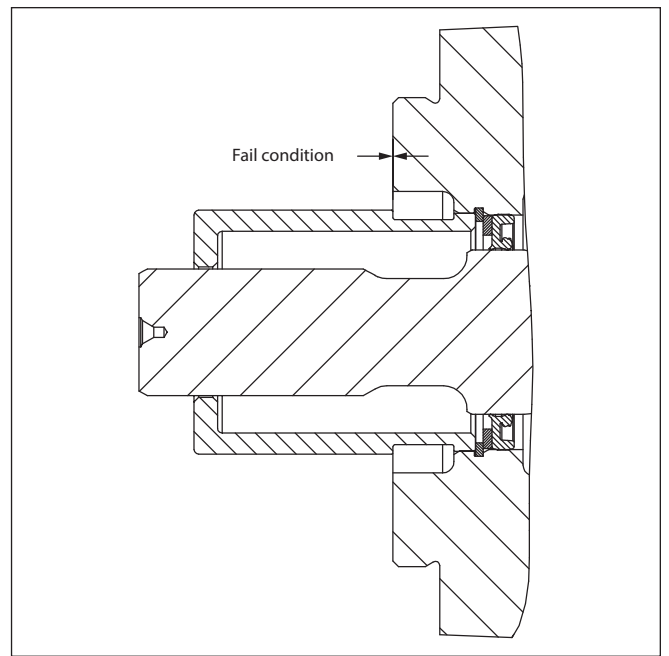
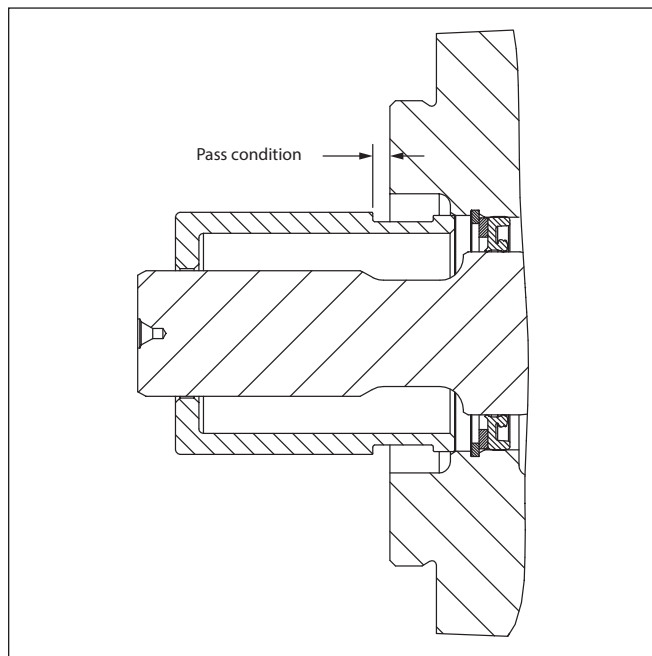

Figure 9. No go dust seal gauge conditions

Series 1 shaft seal installation instructions

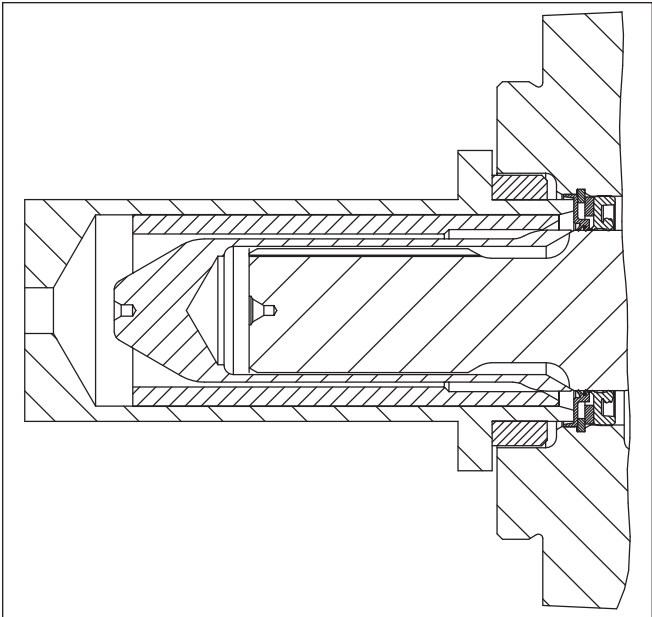

Figure 10. Dust seal installation

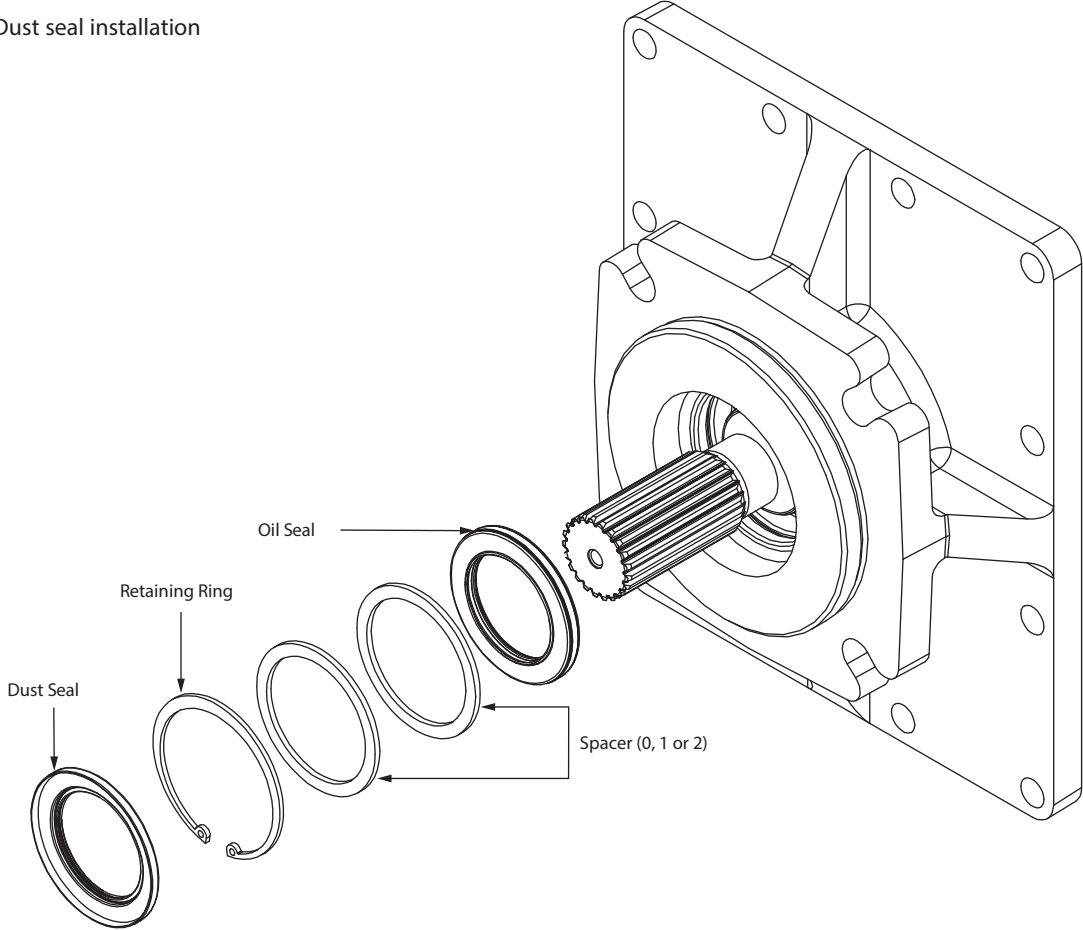

Figure 11. Parts exploded view

Installation tools

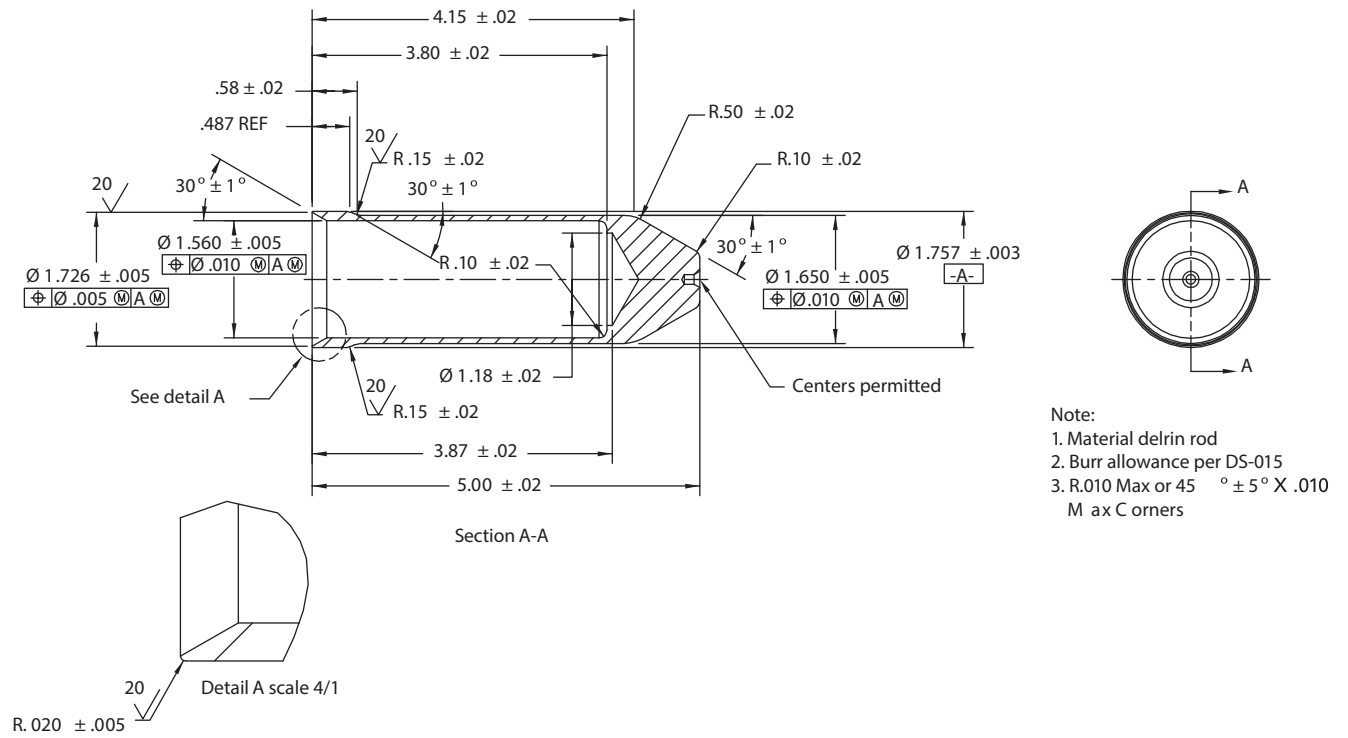

Figure 12. Seal bullet (6041669-001) for input shaft options equal to or smaller than 23Tooth 16/32 Pitch splines (Ø1.486" maximum diameter)

Series 1 shaft seal installation instructions

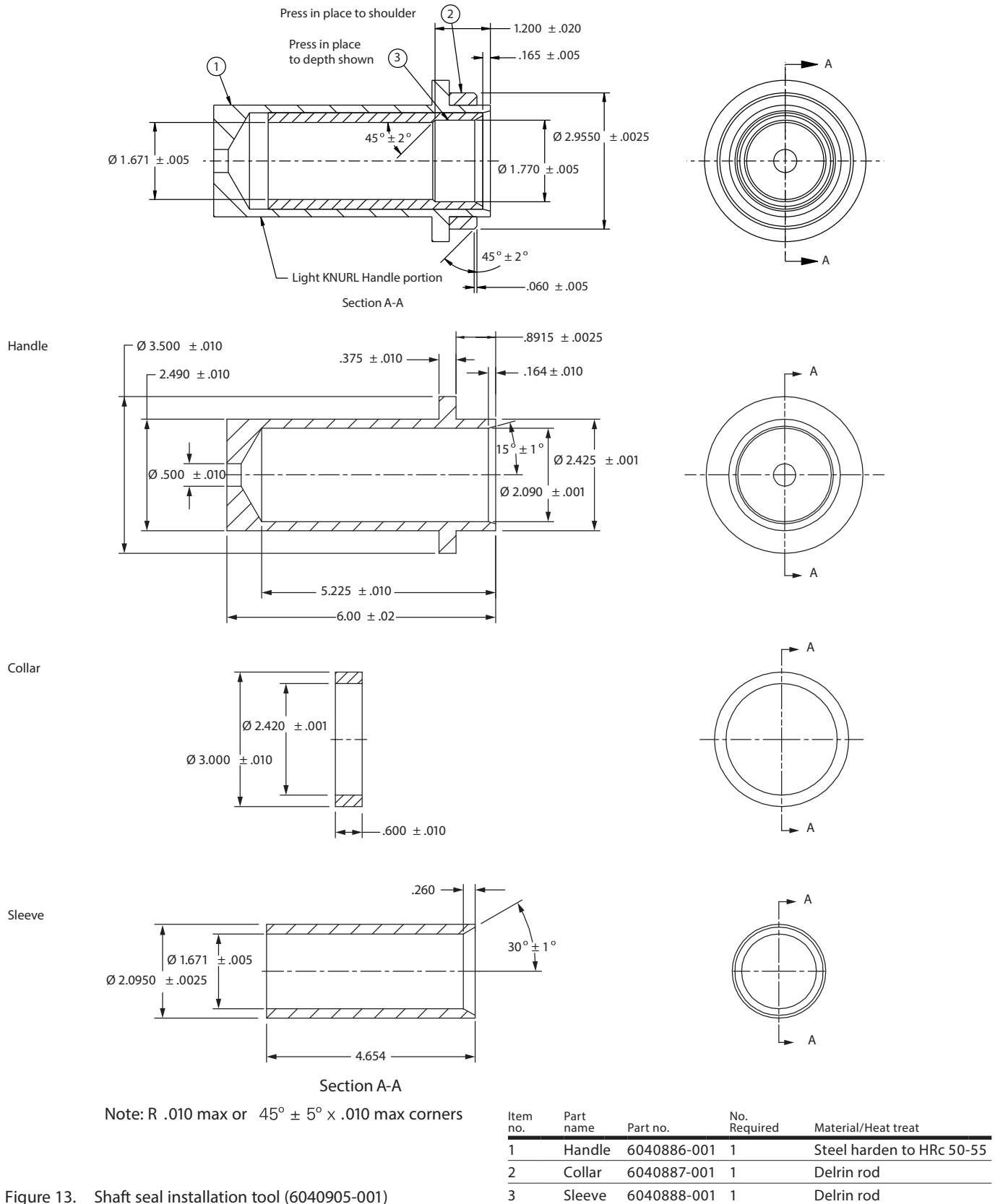
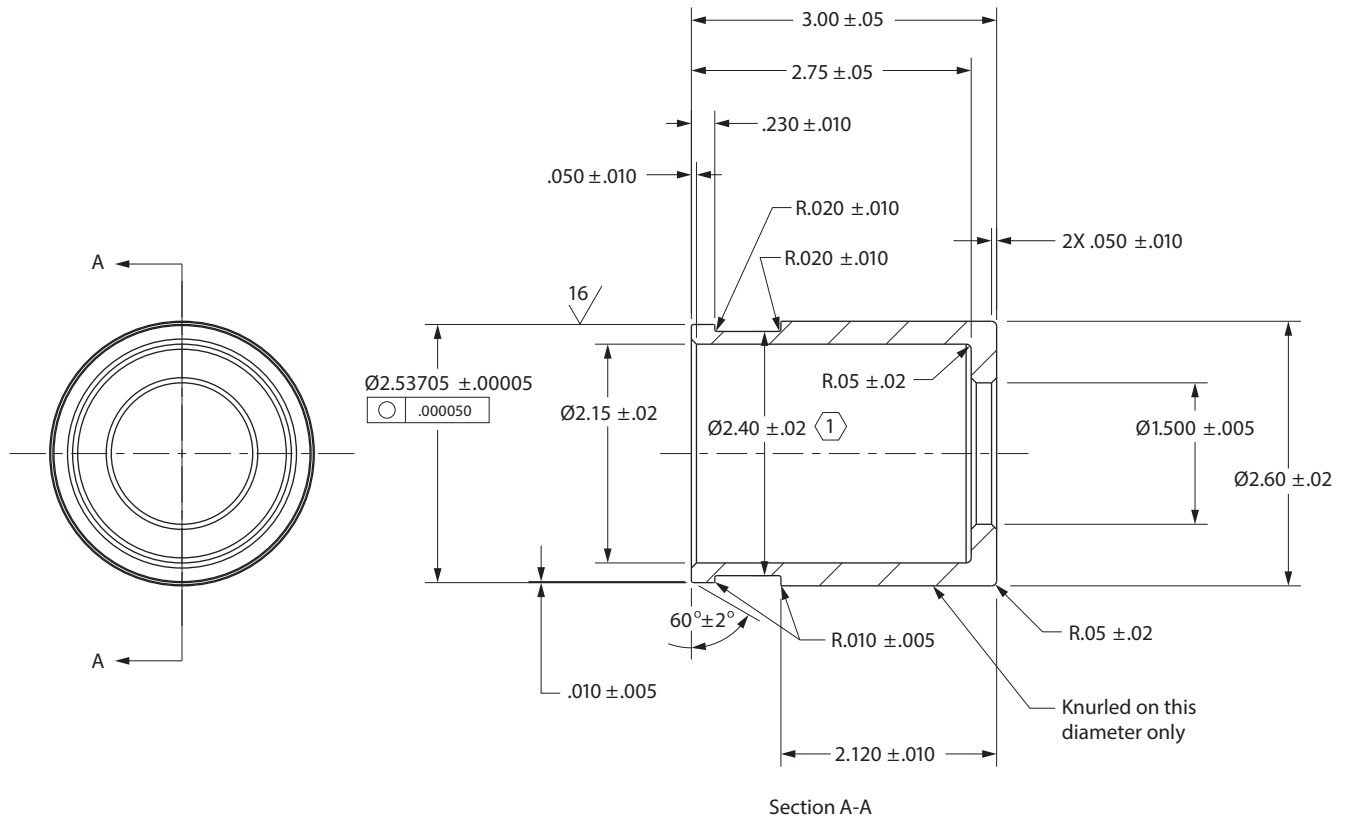

Figure 13. Shaft seal installation tool (6040905-001)



Burr allowance per DS-015
R.010 Max corners

1 Stamp part number and revision letter on tool diameter

Material/Heat treat:
8620 Steel 60-62 HRc
.015 Min effective case depth per PS-039

Figure 14. Dust Seal No Go Gauge (6040727-001)

Seal kit part number: 9901181-000

(For 33/39/46/54/64 Series 1 units and 33/39/46 Series 2 units .)

| Part no. | Qty. | Description |
|-------------|------|----------------------------|
| 6040479-001 | 1 | Drive shaft seal (Viton) |
| 107836-000 | 2 | Shaft seal spacer (0.095") |
| 5996961-001 | 1 | Shaft seal spacer (0.150") |
| 101680-250 | 1 | Retaining ring |
| 6040478-001 | 1 | Dust seal (Viton) |

Seal kit part number: 9901258-000 (without dust seal)

(For 33/39/46/54/64 Series 1 units and 33/39/46 Series 2 units .)

| Part no. | Qty. | Description |
|-------------|------|----------------------------|
| 6040479-001 | 1 | Drive shaft seal (Viton) |
| 107836-000 | 2 | Shaft seal spacer (0.095") |
| 5996961-001 | 1 | Shaft seal spacer (0.150") |
| 101680-250 | 1 | Retaining ring |

Products we offer:

- Cartridge valves
- DCV directional control valves
- Electric converters
- Electric machines
- Electric motors
- Gear motors
- Gear pumps
- Hydraulic integrated circuits (HICs)
- Hydrostatic motors
- Hydrostatic pumps
- Orbital motors
- PLUS+1® controllers
- PLUS+1® displays
- PLUS+1® joysticks and pedals
- PLUS+1® operator interfaces
- PLUS+1® sensors
- PLUS+1® software
- PLUS+1® software services, support and training
- Position controls and sensors
- PVG proportional valves
- Steering components and systems
- Telematics

Danfoss Power Solutions is a global manufacturer and supplier of high-quality hydraulic and electric components. We specialize in providing state-of-the-art technology and solutions that excel in the harsh operating conditions of the mobile off-highway market as well as the marine sector. Building on our extensive applications expertise, we work closely with you to ensure exceptional performance for a broad range of applications. We help you and other customers around the world speed up system development, reduce costs and bring vehicles and vessels to market faster.

Danfoss Power Solutions – your strongest partner in mobile hydraulics and mobile electrification.

Go to www.danfoss.com for further product information.

We offer you expert worldwide support for ensuring the best possible solutions for outstanding performance. And with an extensive network of Global Service Partners, we also provide you with comprehensive global service for all of our components.

Local address:

Hydro-Gear

www.hydro-gear.com

Daikin-Sauer-Danfoss

www.daikin-sauer-danfoss.com

**Danfoss
Power Solutions (US) Company**
2800 East 13th Street
Ames, IA 50010, USA
Phone: +1 515 239 6000

**Danfoss
Power Solutions GmbH & Co. OHG**
Krokamp 35
D-24539 Neumünster, Germany
Phone: +49 4321 871 0

**Danfoss
Power Solutions ApS**
Nordborgvej 81
DK-6430 Nordborg, Denmark
Phone: +45 7488 2222

**Danfoss
Power Solutions Trading
(Shanghai) Co., Ltd.**
Building #22, No. 1000 Jin Hai Rd
Jin Qiao, Pudong New District
Shanghai, China 201206
Phone: +86 21 2080 6201