



# Pilot Operated Check Valves Technical Information

## Quick Reference

Pilot to Open	Model No.	Cavity	Description	Flow*	Pressure	Page
	<b>RPC04</b>	<b>NCS04/3</b>	Pilot Operated Check Valve, Pilot to Open	20.5 l/min [5.4 US gal/min]	350 bar [5075 psi]	<b>PO - 6</b>
	<b>RPC06</b>	<b>NCS06/3</b>		35 l/min [9.3 US gal/min]	350 bar [5075 psi]	<b>PO - 7</b>
	<b>CP450-1</b>	<b>SDC10-3</b>		30 l/min [8 US gal/min]	240 bar [3480 psi]	<b>PO - 8</b>
	<b>RPC12</b>	<b>NCS12/3</b>		90 l/min [23.8 US gal/min]	315 bar [4570 psi]	<b>PO - 9</b>

Pilot to Open	Model No.	Cavity	Description	Flow*	Pressure	Page
	<b>CP458-2</b>	<b>SDC08-3</b>	Pilot Operated Check Valve, Reverse Pilot to Open	20 l/min [5 US gal/min]	210 bar [3045 psi]	<b>PO - 10</b>
	<b>MC10-RO</b>	<b>SDC10-3S</b>		45 l/min [12 US gal/min]	250 bar [3600 psi]	<b>PO - 11</b>
	<b>CP451-2</b>	<b>CP12-3S</b>		95 l/min [25 US gal/min]	210 bar [3045 psi]	<b>PO - 12</b>
	<b>CP452-2</b>	<b>SDC16-3S</b>		130 l/min [34 US gal/min]	210 bar [3045 psi]	<b>PO - 13</b>
	<b>CP453-2</b>	<b>CP20-3S</b>		230 l/min [61 US gal/min]	210 bar [3045 psi]	<b>PO - 14</b>

Pilot to Open	Model No.	Cavity	Description	Flow*	Pressure	Page
	<b>RPV 06</b>	<b>NCS06/4</b>	Pilot Operated Check Valve, Pilot-to-open with drain	30 l/min [8 US gal/min]	315 bar [4570 psi]	<b>PO - 15</b>

\* Flow ratings are based on a pressure drop of 7 bar [100 psi] unless otherwise noted. They are for comparison purposes only.



# Pilot Operated Check Valves Technical Information

## Quick Reference

Symbol	Model No.	Cavity	Description	Flow*	Pressure	Page
	<b>CP453-5</b>	<b>SDC20-2</b>	Pilot Operated Check Valve, Reverse Pilot-to-open with vent	250 l/min [66 US gal/min]	350 bar [5075 psi]	<b>PO - 16</b>

Pilot to Close	Model No.	Cavity	Description	Flow*	Pressure	Page
	<b>CP460-1</b>	<b>SDC10-3</b>	Pilot Operated Check Valve, Pilot to Close	45 l/min [12 US gal/min]	210 bar [3045 psi]	<b>PO - 17</b>
	<b>CP461-1</b>	<b>CP12-3S</b>		115 l/min [30 US gal/min]	210 bar [3045 psi]	<b>PO - 18</b>
	<b>CP462-1</b>	<b>SDC16-3S</b>		190 l/min [50 US gal/min]	210 bar [3045 psi]	<b>PO - 19</b>

Dual Pilot-Operated Checks	Model No.	Cavity	Description	Flow*	Pressure	Page
	<b>CP410-1</b>	none	Pilot Operated Check Valve, Catalog HIC	80 l/min [21.1 US gal/min]	210 bar [3045 psi]	<b>PO - 20</b>

\* Flow ratings are based on a pressure drop of 7 bar [100 psi] unless otherwise noted. They are for comparison purposes only.



### MOTION CONTROL VALVES

Motion control valves, also referred to as load holding valves, are used to control the motion of a load in the following ways:

- Prevent a load from dropping in case of hose or tube failure.
- Prevent a load from drifting caused by directional control valve spool leakage.
- Provide smooth, modulated motion when the load is in a lowering or run-away mode.
- Provide smooth, modulated motion when the directional control valve is suddenly closed.

There are two basic types of motion control valves:

- Pilot-operated, or pilot-to-open check valves will satisfy the first two of the above requirements.
- Counterbalance valves will satisfy all four of the above requirements.

Pilot operated check valves





### PILOT-OPERATED CHECK VALVES

Pilot-operated, or pilot-to-open check valves will positively hold a pressurized load and will release the load upon application of a pressure signal to the pilot port. Pilot-operated check valves are available as individual cartridges, standard **Cartridge-In-Body (CIB)** packages, or can be created in custom manifolds by using a standard check valve such as CV10-NP with a guided pilot piston. For more information on pilot pistons, see Accessories.

Individual cartridges

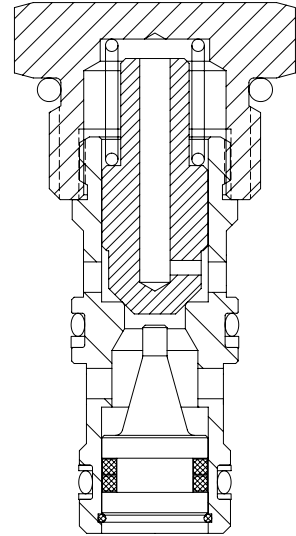

Cartridge in body

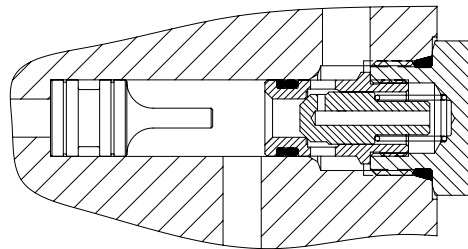

A typical circuit application for pilot-operated check valves contains a pump, directional control valve, and an actuator. Without a pilot-operated check valve the load will drift down due to spool leakage if the directional control valve is centered with the load raised. Additionally there is no protection against the load dropping in the event of hydraulic line failure. Adding a pilot-operated check valve helps prevent cylinder drift and provides protection against hose or tube failure. In this circuit, moving the directional control valve to the right causes the cylinder to extend. When the directional control valve is centered, the pilot-operated check valve will prevent leakage and lock the cylinder in position. Moving the directional control valve to the left sends pressure/flow to the rod end of the cylinder. This pressure also acts on the pilot piston to open the check valve and allow the load to be lowered.

Typical circuit application

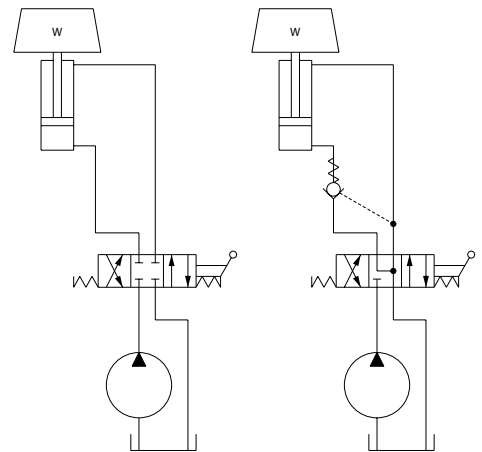

### PILOT-OPERATED CHECK VALVES

(continued)

The pressure required to pilot open the check valve can be calculated by:

$$P = \frac{W + (P_c \cdot A_b)}{(A_b \cdot R) - A_r} \quad \text{cylinder retracts}$$

$$P = \frac{W + (P_c \cdot A_r)}{(A_r \cdot R) - A_b} \quad \text{cylinder extends}$$

$W$  = Load

$P_c$  = Check valve crack pressure (typically 0.34-4.5 bar [5-65 psi]; consult catalog sheets for details)

$A_b$  = Cylinder bore area

$A_r$  = Cylinder rod area

$R$  = Check valve pilot ratio (typically 3:1 or 4:1; consult catalog sheets for details)

Note that these equations are idealized and do not consider any backpressure in the circuit, which is additive to the pressure required to pilot open the check valve.

Some additional guidelines for pilot-operated check valve applications:

- Use pilot-operated check valves for load holding, not for motion (speed) control. Pilot-operated check valves are on-off, non-modulating devices. Trying to use a pilot-operated check valve to control an overrunning load can result in severely unstable motion. For motion (speed) control of overrunning loads, use a counterbalance valve.
- Use caution when applying pilot-operated check valves to the rod end of a cylinder. Cylinders with large rod:bore diameter ratios may intensify rod pressure to a point where the required pilot pressure may be dangerously high—refer to the above equations. If intensification creates application concerns, consider using a counterbalance valve.
- Do not use pilot-operated check valves with closed-center, directional control valves. Pressure trapped between the directional control valve and the pilot-operated check valve can pilot the check valve open and result in undesired load motion.
- Locate pilot-operated check valves at or near the actuator to provide maximum load holding protection in the event of hydraulic line failure.

Closed center, directional control valves

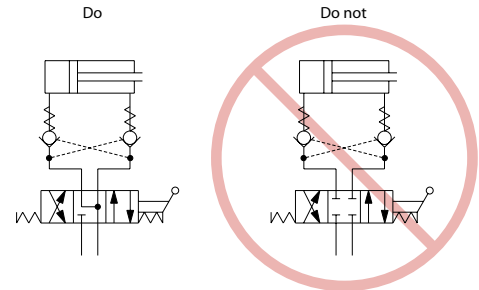



# Pilot Operated Check Valves Technical Information

## Pilot to Open RPC04

### OPERATION

This is a pilot-to-open check valve.

### Schematic

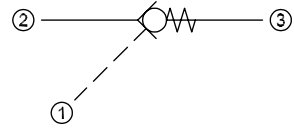

### SPECIFICATIONS

#### Theoretical performance

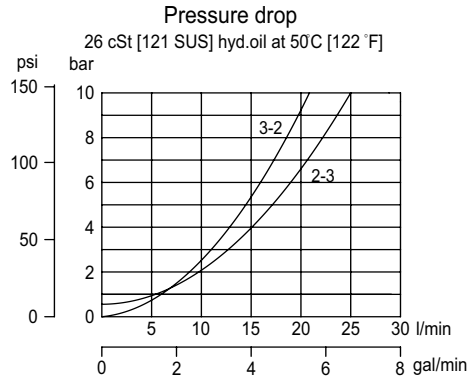

### Specifications

<b>Rated pressure*</b>	350 bar [5075 psi]
<b>Rated flow at 7 bar [100 psi]</b>	20.5 l/min [5.4 US gal/min]
<b>Weight</b>	0.06 kg [0.13 lb]
<b>Pilot ratio</b>	3.2:1
<b>Cavity</b>	<b>NCS04/3</b>

\*Rated Pressure based on NFPA fatigue test standard (at 1 million cycles)

Note: A piston seal requires a 5 bar [72.5 psi] or greater return spring.

### DIMENSIONS

mm [in]

#### Cross-sectional view

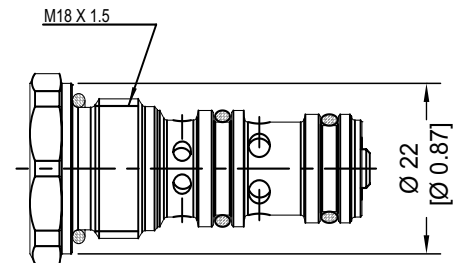
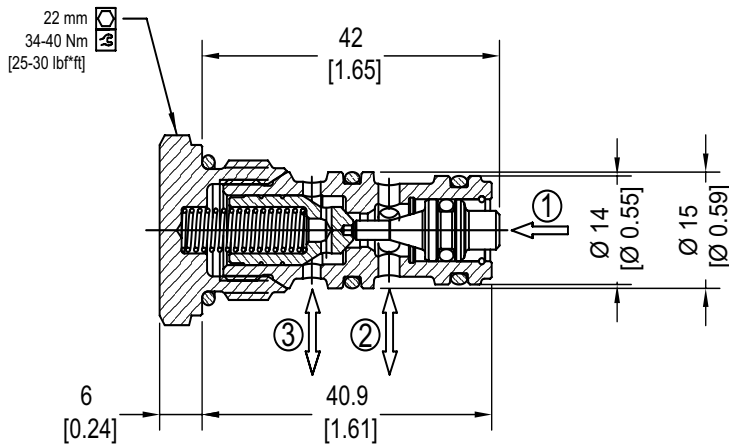

### ORDERING INFORMATION

#### RPC04-2.5-OR-00-V

Pilot to Open

Crack Pressure	
0.5	0.5 bar [7 psi]
2.5	2.5 bar [36.25 psi]
5	5 bar [72.5 psi]
8	8 bar [116 psi]
15	15 bar [217.5 psi]

#### Pilot Seal Option

Omit	No seals
OR	Seals

Seal Option	Seal Kit
Omit = Buna-N	230000160
V = Viton	230000450

Code	Ports & Material	Body Nomenclature
00	00 = Cartridge only	No Housing
SE1/4	AL, 1/4 BSP	NCS04/3-SE-1/4
SE4S	AL, #4 SAE	NCS04/3-SE-4S
SE6S	AL, #6 SAE	NCS04/3-SE-6S

\*\* Aluminum bodies are to be used for pressures less than 210 bar (3000 psi)

\*\*\*Other housings available



# Pilot Operated Check Valves Technical Information

## Pilot to Open RPC06

### OPERATION

This is a pilot-to-open check valve.

### Schematic

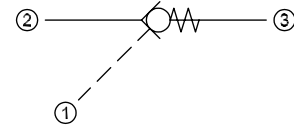

### SPECIFICATIONS

#### Theoretical performance

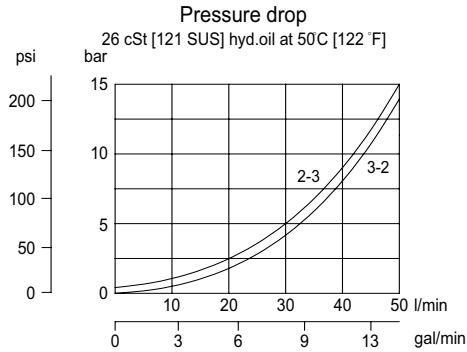

### Specifications

<b>Rated pressure*</b>	350 bar [5075 psi]
<b>Rated flow at 7 bar [100 psi]</b>	35 l/min [9.25 US gal/min]
<b>Weight</b>	0.10 kg [0.22 lb]
<b>Pilot ratio</b>	3.4:1
<b>Cavity</b>	<b>NCS06/3</b>

\*Rated pressure based on NFPA fatigue test standard (at 1 million cycles)

Note: A piston seal requires a 5 bar [72.5 psi] or greater return spring.

### DIMENSIONS

mm [in]

#### Cross-sectional view

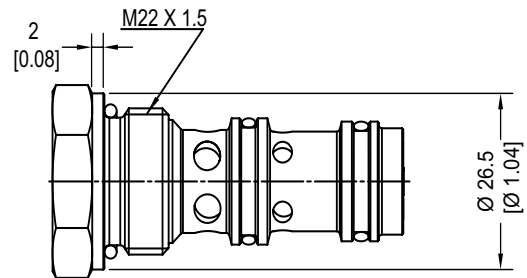
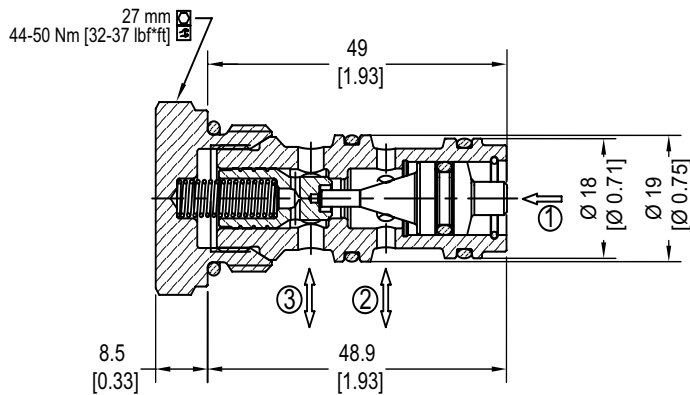

### ORDERING INFORMATION

RPC06-5-OR-00-V

Pilot to Open

Crack Pressure	
0.5	0.5 bar [7 psi]
2	2 bar [30 psi]
5	5 bar [72.5 psi]
10	10 bar [145 psi]

Pilot Seal Option	
Omit	No seals
OR	Seals

Seal Option	Seal Kit
Omit = Buna-N	230000070
V = Viton	230000110

Code	Ports & Material	Body Nomenclature
00	00 = Cartridge only	No Housing
SE3/8	AL, 3/8 BSP	NCS06/3-SE-3/8
SE1/2	AL, 1/2 BSP	NCS06/3-SE-1/2
SE6S	AL, #6 SAE	NCS06/3-SE-6S
SE8S	AL, #8 SAE	NCS04/3-SE-8S

\*\* Aluminum bodies are to be used for pressures less than 210 bar (3000 psi)  
\*\*\* Other housings available



# Pilot Operated Check Valves Technical Information

## Pilot to Open

### CP450-1

#### OPERATION

This valve is a pilot-to-open check valve.

#### Schematic

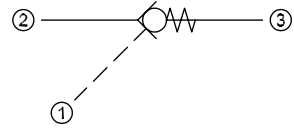

#### SPECIFICATIONS

#### Theoretical performance

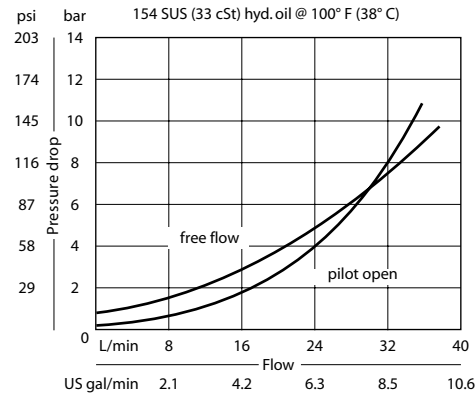

#### Specifications

<b>Rated pressure</b>	240 bar [3480 psi]
<b>Rated flow at 7 bar [100 psi]</b>	30 l/min [8 US gal/min]
<b>Leakage</b>	6 drops/min @ Rated pressure
<b>Weight</b>	0.09 kg [0.20 lb]
<b>Pilot ratio</b>	3.0:1
<b>Cavity</b>	<b>SDC10-3</b>

Note: A piston seal requires a 4.5 bar [65 psi] or greater return spring.

#### DIMENSIONS

mm [in]

#### Cross-sectional view

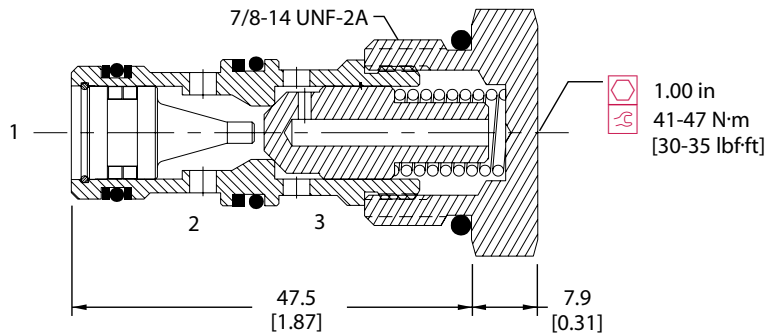

#### ORDERING INFORMATION

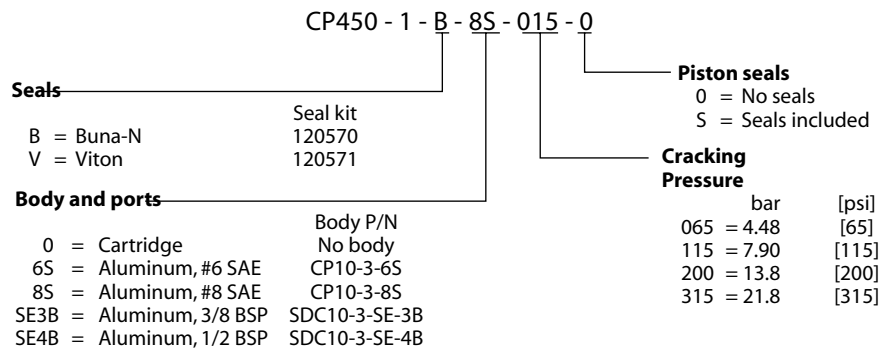





# Pilot Operated Check Valves Technical Information

## Pilot to Open RPC12

### OPERATION

This is a pilot-to-open check valve.

### Schematic

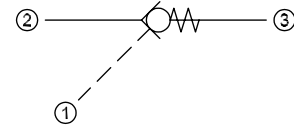

### SPECIFICATIONS

#### Theoretical performance

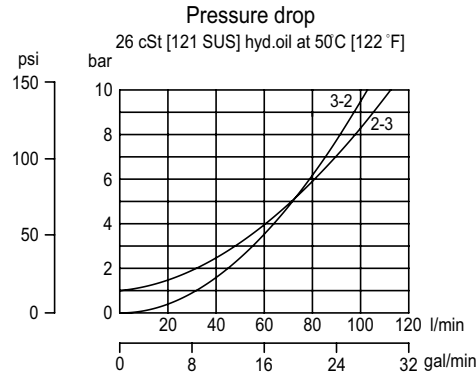

#### Specifications

<b>Rated pressure</b>	315 bar [4570 psi]
<b>Rated flow at 7 bar [100 psi]</b>	90 l/min [23.8 US gal/min]
<b>Weight</b>	0.20 kg [0.44 lb]
<b>Pilot ratio</b>	2.8:1
<b>Cavity</b>	<b>NCS12/3</b>

Note: A piston seal requires a 5 bar [72.5 psi] or greater return spring.

### DIMENSIONS

mm [in]

#### Cross-sectional view

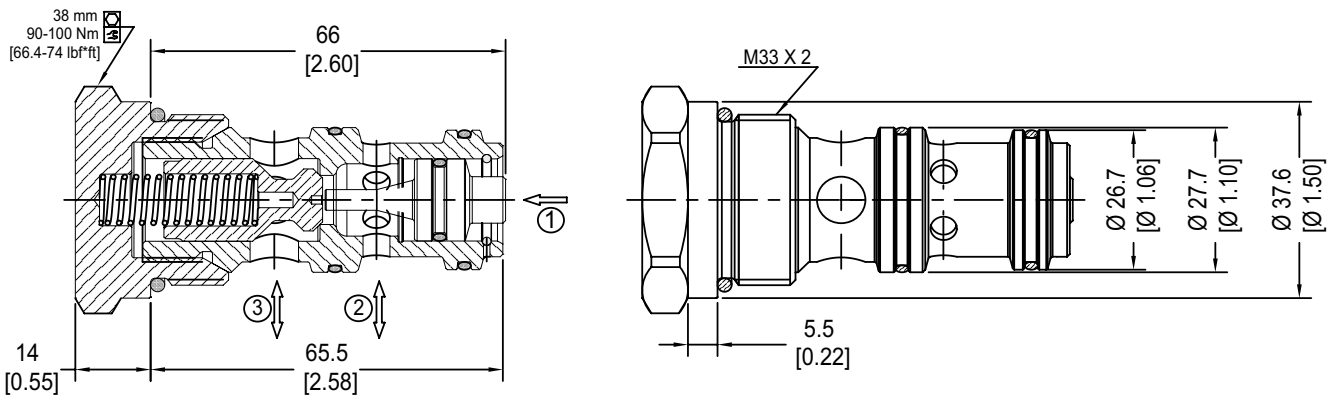

### ORDERING INFORMATION

#### RPC12-5-OR-00-V

Pilot to Open

Crack Pressure	
0.5	0.5 bar [7 psi]
2.5	2.5 bar [36.2psi]
5	5.0 bar [72.5 psi]
10	10 bar [145 psi]

Pilot Seal Option	
Omit	No Seals
OR	Seals

Seal Option	Seal Kit
Omit = Buna-N	230000130
V = Viton	230000360

Code	Ports & Material	Body Nomenclature
00	00 = Cartridge only	00 = Cartridge only
SE1/2	AL, 1/2 BSP	NCS12/3-SE-1/2
SE3/4	AL, 3/4 BSP	NCS12/3-SE-3/4
SE8S	AL, #8 SAE	NCS12/3-SE-8S
SE12S	AL, #12 SAE	NCS12/3-SE-12S

\*\*Aluminum bodies are to be used for pressures less than 210 bar (3000 psi)  
\*\*\*Other housings available



# Pilot Operated Check Valves Technical Information

## Reverse Pilot to Open

### CP458-2

#### OPERATION

This valve is a pilot-to-open check valve.

#### Schematic

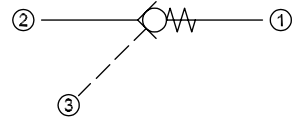

#### SPECIFICATIONS

#### Theoretical performance

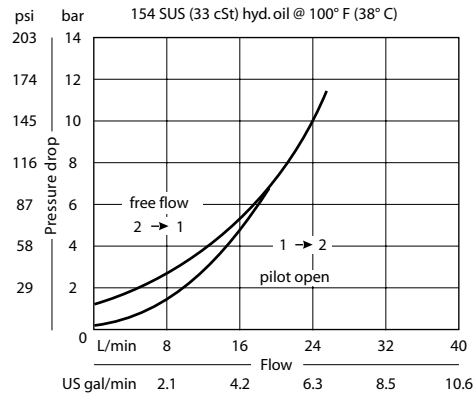

#### Specifications

<b>Rated pressure</b>	210 bar [3045 psi]
<b>Rated flow at 7 bar [100 psi]</b>	20 l/min [5 US gal/min]
<b>Leakage</b>	6 drops/min @ Rated pressure
<b>Weight</b>	0.07 kg [0.15 lb]
<b>Pilot ratio</b>	2.8:1
<b>Cavity</b>	<b>SDC08-3</b>

Note: A piston seal requires a 4.5 bar [65 psi] or greater return spring.

#### DIMENSIONS

mm [in]

#### Cross-sectional view

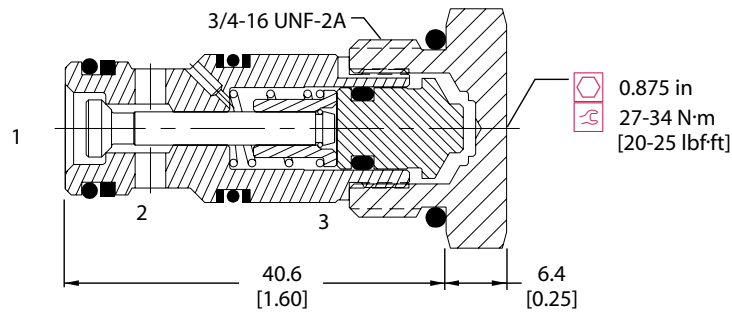

#### ORDERING INFORMATION

**CP458 - 2 - B - 6S - 065 - 0**

<b>Seals</b>	<b>Seal kit</b>	<b>Piston seals</b>
B = Buna-N	120250	0 = No seals
V = Viton	120253	S = Seals included
<b>Housing and ports</b>	<b>Housing P/N</b>	<b>Crack Pressure</b>
0 = No Housing	No Housing	bar [psi]
SE2B = Al, 1/4 BSP	SDC08-3-SE-2B	065 = 4.48 [65]
SE3B = Al, 3/8 BSP	SDC08-3-SE-3B	
4S = Al, #4 SAE	CP08-3-4S	
6S = Al, #6 SAE	CP08-3-6S	
Other housings available		



# Pilot Operated Check Valves Technical Information

## Reverse Pilot to Open

### MC10-RO

#### OPERATION

This is a pilot-to-open check valve.

#### Schematic

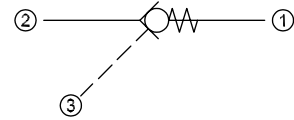

#### SPECIFICATIONS

#### Theoretical performance

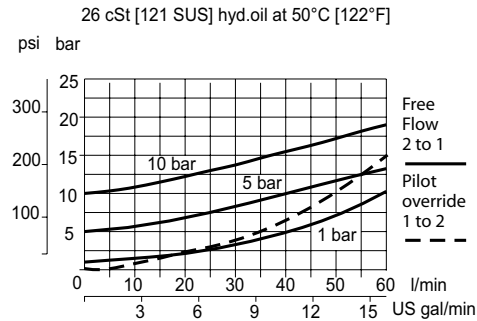

#### Specifications

<b>Rated pressure</b>	250 bar [3600 psi]
<b>Rated flow at 7 bar [100 psi]</b>	45 l/min [12 US gal/min]
<b>Leakage</b>	6 drops/min @ Rated pressure
<b>Weight</b>	0.12 kg [0.26 lb]
<b>Pilot ratio</b>	3.0:1
<b>Cavity</b>	<b>SDC10-3S</b>

Note: A piston seal requires a 4.5 bar [65 psi] or greater return spring.

#### DIMENSIONS

mm [in]

#### Cross-sectional view

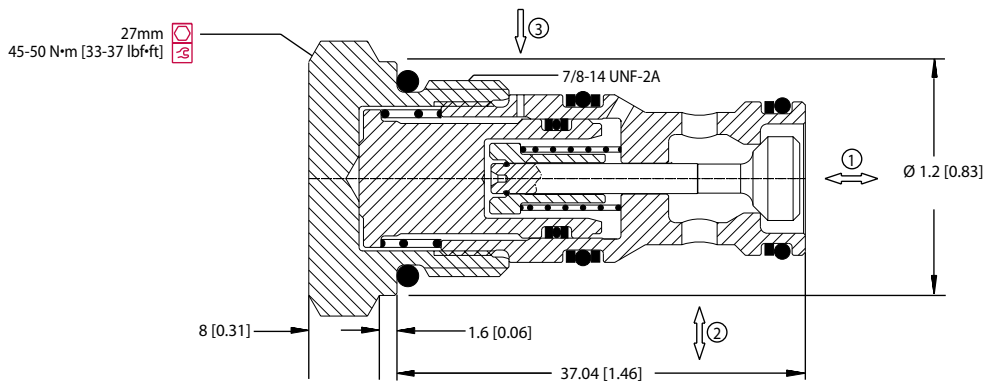

P103 753

#### ORDERING INFORMATION

#### MC10-RO-5-OR-A-B-6S

**Crack Pressure**  
1 = 1 bar [15 psi]  
5 = 5 bar [73 psi]  
10 = 10 bar [145 psi]

**Piston seals**  
Omit = No seal  
OR = Seals included

#### Housing and ports

00 = No Housing  
SE3B = Al, 3/8 BSP  
SE4B = Al, 1/2 BSP  
6S = Al, #6 SAE  
8S = Al, #8 SAE  
Other housings available

**Seals**      **Seal kit**  
B = Buna-N    35401419  
V = Viton      35401519

#### Housing P/N

No Housing  
SDC10-3S-SE-3B  
SDC10-3S-SE-4B  
SDC10-3S-6S/6S  
SDC10-3S-8S/6S



# Pilot Operated Check Valves Technical Information

## Reverse Pilot to Open

### CP451-2

#### OPERATION

This valve is a pilot-to-open check valve.

#### Schematic

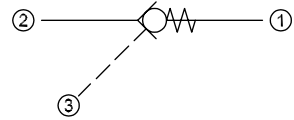

#### SPECIFICATIONS

#### Theoretical performance

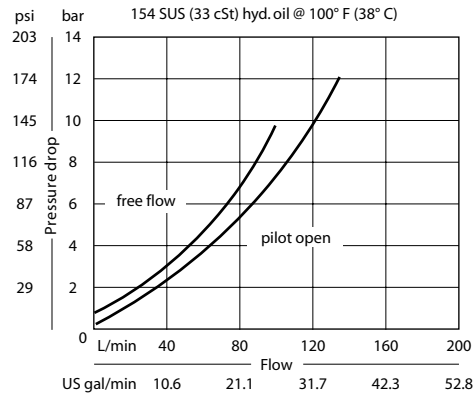

#### Specifications

<b>Rated pressure</b>	210 bar [3045 psi]
<b>Rated flow at 7 bar [100 psi]</b>	95 l/min [25 US gal/min]
<b>Leakage</b>	6 drops/min @ Rated pressure
<b>Weight</b>	0.21 kg [0.46 lb]
<b>Pilot ratio</b>	3:1
<b>Cavity</b>	<b>CP12-3S</b>

Note: A piston seal requires a 4.5 bar [65 psi] or greater return spring.

#### DIMENSIONS

mm [in]

#### Cross-sectional view

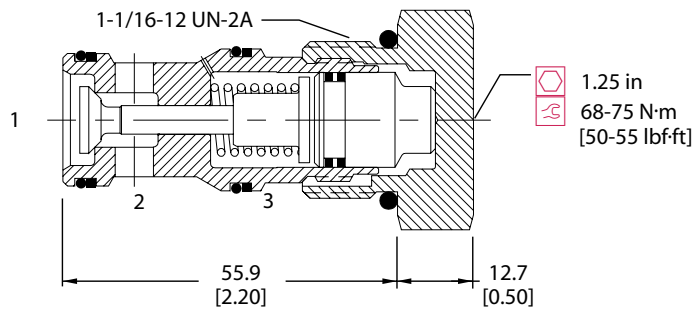

#### ORDERING INFORMATION

**CP451 - 2 - B - 12S - 065 - 0**

<p><b>Seals</b></p> <p>B = Buna-N V = Viton</p> <p><b>Housing and ports</b></p> <p>0 = No Housing 4B = Al, 1/2 BSP 6B = Al, 3/4 BSP 10S = Al, #10 SAE 12S = Al, #12 SAE Other housings available</p>	<p><b>Seal kit</b></p> <p>120335 120336</p> <p><b>Housing P/N</b></p> <p>No Housing CP12-3S-4B/2B CP12-3S-6B/2B CP12-3S-10S/4S CP12-3S-12S/4S</p>	<p><b>Piston seals</b></p> <p>0 = No seals S = Seals included</p> <p><b>Crack Pressure</b></p> <p>065 = 4.48 bar [65 psi]</p>
--	---	---



# Pilot Operated Check Valves Technical Information

## Reverse Pilot to Open

### CP452-2

#### OPERATION

This valve is a pilot-to-open check valve.

#### Schematic

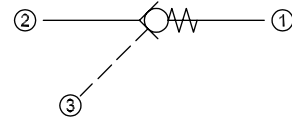

#### SPECIFICATIONS

#### Theoretical performance

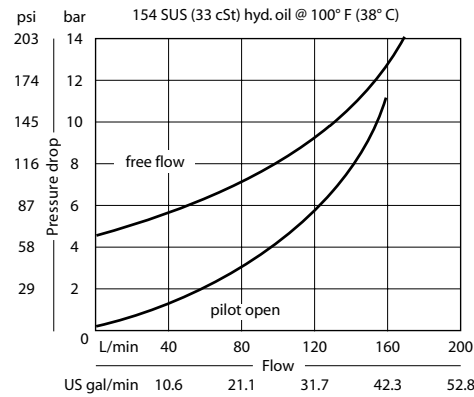

#### Specifications

<b>Rated pressure</b>	210 bar [3045 psi]
<b>Rated flow at 7 bar [100 psi]</b>	130 l/min [34 US gal/min]
<b>Leakage</b>	6 drops/min @ Rated pressure
<b>Weight</b>	0.29 kg [0.64 lb]
<b>Pilot ratio</b>	3:1
<b>Cavity</b>	<b>SDC16-3S</b>

Note: A piston seal requires a 4.5 bar [65 psi] or greater return spring.

#### DIMENSIONS

mm [in]

#### Cross-sectional view

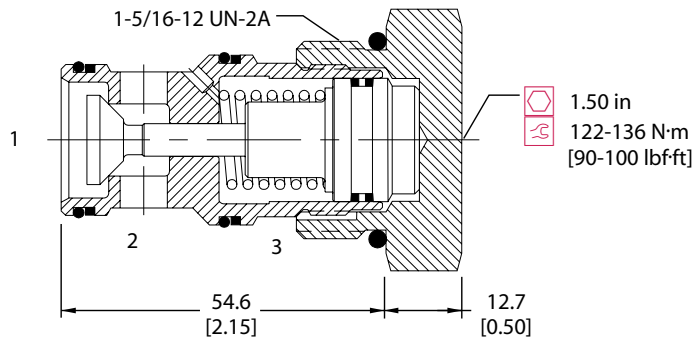

#### ORDERING INFORMATION

### CP452-2 - B - 16S - 065 - 0

#### Seal Option

Code	Seal Material	Seal kit
B	Buna	120033
V	Viton	120034

#### Piston Seals

Code	Description
0	No seals
S	Seals Included

Housings & Ports	Housing P/N
0: Cartridge Only	No Housing
6B: 3/4 BSP, AL	CP16-3S-6B/2B
8B: 1 BSP, AL	CP16-3S-8B/2B
12S: #12 SAE, AL	CP16-3S-12S/4S
16S: #16 SAE, AL	CP16-3S-16S/4S

Other Housings available

#### Crack Pressure

Code	bar	[psi]
065	4.48	[65]



# Pilot Operated Check Valves Technical Information

## Reverse Pilot to Open

### CP453-2

#### OPERATION

This valve is a pilot-to-open check valve.

#### Schematic

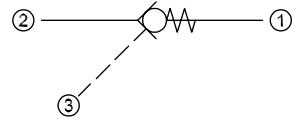

#### SPECIFICATIONS

##### Theoretical performance

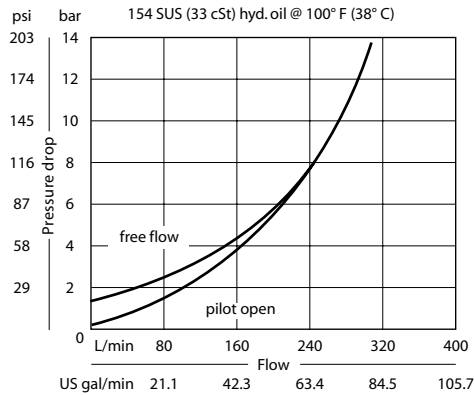

##### Specifications

<b>Rated pressure</b>	210 bar [3045 psi]
<b>Rated flow at 7 bar [100 psi]</b>	230 l/min [61 US gal/min]
<b>Leakage</b>	6 drops/min @ Rated pressure
<b>Weight</b>	0.66 kg [1.46 lb]
<b>Pilot ratio</b>	3:1
<b>Cavity</b>	<b>CP20-3S</b>

Note: A piston seal requires a 4.5 bar [65 psi] or greater return spring.

#### DIMENSIONS

mm [in]

##### Cross-sectional view

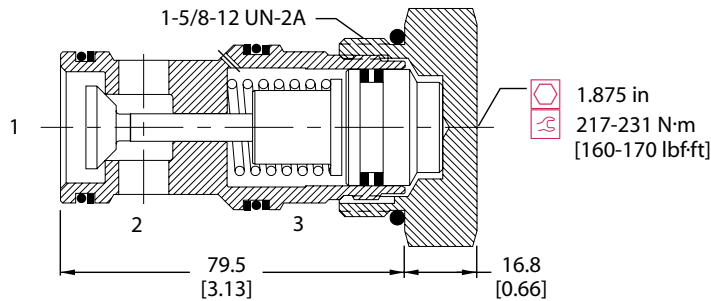

#### ORDERING INFORMATION

**CP453 - 2 - B - 20S - 065 - 0**

<b>Seals</b> B = Buna-N V = Viton	<b>Seal kit</b> 120380 120381	<b>Piston seals</b> 0 = No seals S = Seals included
<b>Housing and ports</b> 0 = No Housing 8B = Al, 1 BSP 10B = Al, 1-1/4 BSP 16S = Al, #16 SAE 20S = Al, #20 SAE Other housings available	<b>Housing P/N</b> No Housing CP20-3S-8B/2B CP20-3S-10B/2B CP20-3S-16S/4S CP20-3S-20S/4S	<b>Crack Pressure</b> bar [psi] 065 = 4.48 [65]



# Pilot Operated Check Valves Technical Information

## Pilot to Open with Drain

### RPV 06

#### OPERATION

This is a pilot-to-open check valve with an internal drain.

#### Schematic

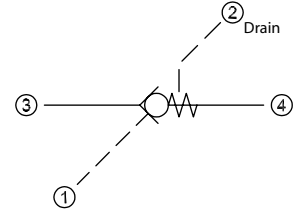

#### SPECIFICATIONS

#### Theoretical performance

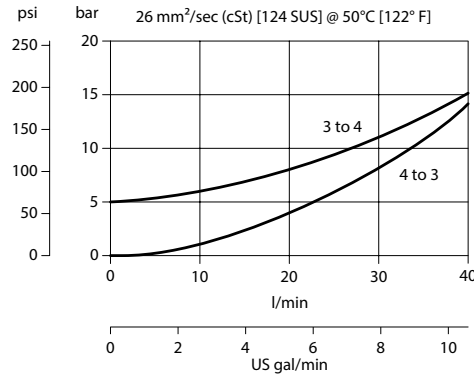

#### Specifications

<b>Rated pressure</b>	315 bar [4570 psi]
<b>Rated flow at 7 bar [100 psi]</b>	30 l/min [8 US gal/min]
<b>Weight</b>	0.13 kg [0.29 lb]
<b>Pilot ratio</b>	3.4:1
<b>Cavity</b>	<b>NCS06/4</b>

Note: A piston seal requires a 4.5 bar [65 psi] or greater return spring.

#### DIMENSIONS

mm [in]

#### Cross-sectional view

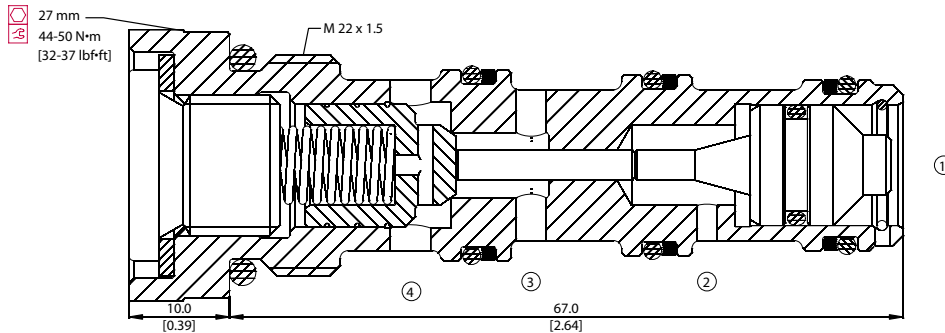

#### ORDERING INFORMATION

RPV 06 - 5 - OR - 00 - V

**Piston seals**  
OR = Seals  
Omit = No seals

**Housing and ports**  
00 = No Housing  
L3/8 = AL, 3/8 BSP  
L3/4 = AL, 3/4 BSP  
L6S = AL, #6 SAE  
L8S = AL, #8 SAE  
Other housings available

**Seals**  
V = Viton  
Omit = Buna-N

**Seal Kit**  
Consult factory  
230000080

**Housing P/N**  
No Housing  
NCS06/4-L-3/8  
NCS06/4-L-1/2  
NCS06/4-L-6S  
NCS06/4-L-8S



# Pilot Operated Check Valves Technical Information

## Reverse Pilot to Open with Vent

### CP453-5

#### OPERATION

This is a pilot-to-open check valve with an external pilot connection.

#### Schematic

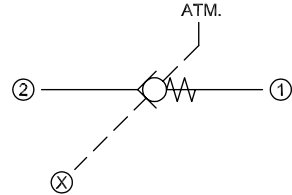

#### SPECIFICATIONS

#### Theoretical performance

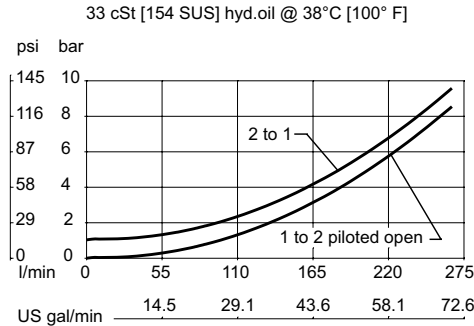

#### Specifications

<b>Rated pressure</b>	350 bar [5075 psi]
<b>Rated flow at 7 bar [100 psi]</b>	250 l/min [66 US gal/min]
<b>Leakage</b>	6 drops/min @ Rated pressure
<b>Weight</b>	1.23 kg [2.71 lb]
<b>Pilot ratio</b>	4:1
<b>Cavity</b>	<b>SDC20-2</b>

Note: A piston seal requires a 4.5 bar [65 psi] or greater return spring.

#### DIMENSIONS

mm [in]

#### Cross-sectional view

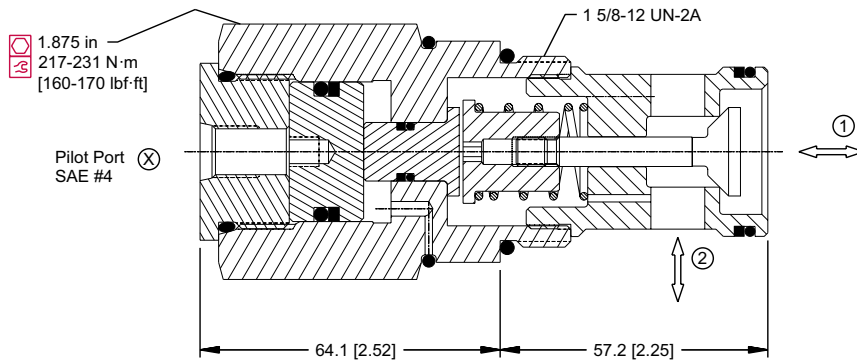

#### ORDERING INFORMATION

**CP453-5-B-16S-4-065**

<b>Seals</b>	<b>Seal kit</b>		<b>Crack Pressure</b>
B = Buna-N V = Viton	120011 120012		bar [psi] 065 = 4.3 65 100 = 6.9 100
<b>Housing and ports</b>		<b>Housing P/N</b>	<b>Pilot ratio</b>
0 = No Housing 8B = AL, 1 BSP 10B = AL, 1-1/4 BSP 16S = AL, #16 SAE 20S = AL, #20 SAE Other housings available		No Housing CP20-2-8B CP20-2-10B CP20-2-16S CP20-2-20S	4 = 4:1





# Pilot Operated Check Valves Technical Information

## Pilot to Close CP460-1

### OPERATION

This valve is a pilot-to-close check valve.

### Schematic

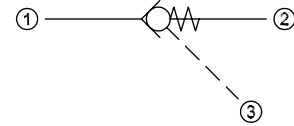

### SPECIFICATIONS

#### Theoretical performance

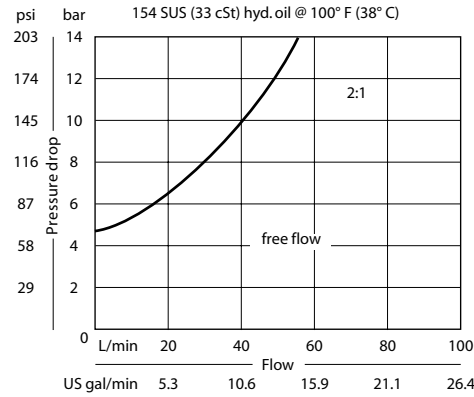

#### Specifications

<b>Rated pressure</b>	210 bar [3045 psi]
<b>Rated flow at 7 bar [100 psi]</b>	45 l/min [12 US gal/min]
<b>Leakage</b>	6 drops/min @ Rated pressure
<b>Weight</b>	0.10 kg [0.21 lb]
<b>Pilot ratio</b>	2:1
<b>Cavity</b>	<b>SDC10-3</b>

Note: A piston seal requires a 4.5 bar [65 psi] or greater return spring.

### DIMENSIONS

mm [in]

#### Cross-sectional view

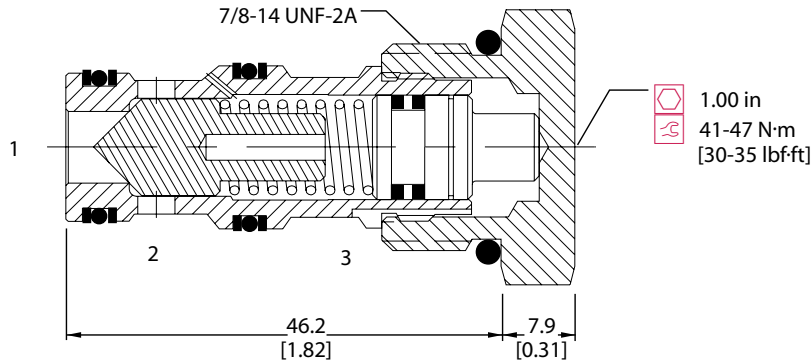

### ORDERING INFORMATION

**CP460 - 1 - B - 8S - 2 - 065 - 0**

<b>Seals</b>	Seal kit	<b>Piston seals</b>	0 = No seals
B = Buna-N	120009	S = Seals included	
V = Viton	120010		
<b>Housing and ports</b>	<b>Housing P/N</b>	<b>Crack Pressure</b>	bar [psi]
0 = No Housing	No Housing	065 = 4.48	[65]
SE3B = Al, 3/8 BSP	SDC10-3-SE-3B		
SE4B = Al, 1/2 BSP	SDC10-3-SE-4B		
6S = Al, #6 SAE	CP10-3-6S	<b>Pilot ratio</b>	
8S = Al, #8 SAE	CP10-3-8S	2 = 2:1	
Other housings available			



# Pilot Operated Check Valves Technical Information

## Pilot to Close

### CP461-1

### OPERATION

This valve is a pilot-to-close check valve.

### Schematic

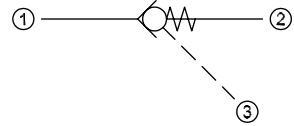

### SPECIFICATIONS

#### Theoretical performance

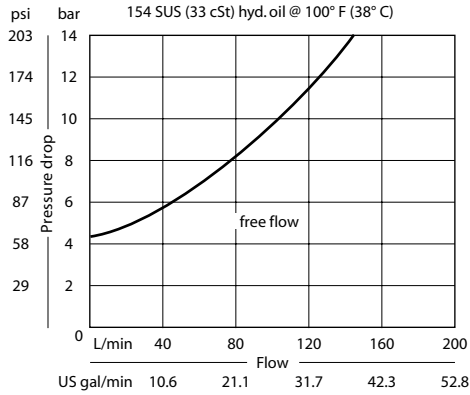

#### Specifications

<b>Rated pressure</b>	210 bar [3045 psi]
<b>Rated flow at 7 bar [100 psi]</b>	115 l/min [30 US gal/min]
<b>Leakage</b>	6 drops/min @ Rated pressure
<b>Weight</b>	0.21 kg [0.47 lb]
<b>Pilot ratio</b>	2.3:1
<b>Cavity</b>	<b>CP12-3S</b>

Note: A piston seal requires a 4.5 bar [65 psi] or greater return spring.

### DIMENSIONS

mm [in]

#### Cross-sectional view

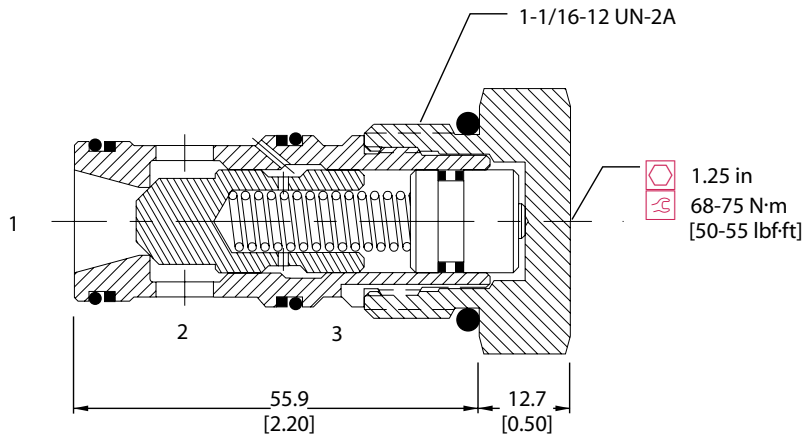

### ORDERING INFORMATION

**CP461 - 1 - B - 12S - 065 - 0**

#### Seals

B = Buna-N  
V = Viton

Seal kit  
120335  
120336

#### Piston seals

0 = No seals  
S = Seals included

#### Housing and ports

0 = No Housing  
4B = Al, 1/2 BSP  
6B = Al, 3/4 BSP  
10S = Al, #10 SAE  
12S = Al, #12 SAE

#### Housing P/N

No Housing  
CP12-3S-4B/2B  
CP12-3S-6B/2B  
CP12-3S-10S/4S  
CP12-3S-12S/4S

Other housings available

#### Crack Pressure

bar [psi]  
065 = 4.48 [65]



# Pilot Operated Check Valves Technical Information

## Pilot to Close

### CP462-1

#### OPERATION

This valve is a pilot-to-close check valve.

#### Schematic

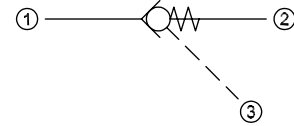

#### SPECIFICATIONS

##### Theoretical performance

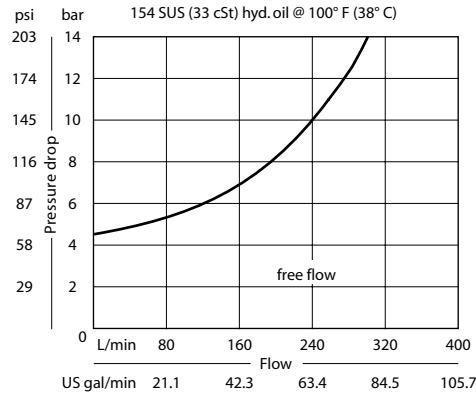

##### Specifications

<b>Rated pressure</b>	210 bar [3045 psi]
<b>Rated flow at 7 bar [100 psi]</b>	190 l/min [50 US gal/min]
<b>Leakage</b>	6 drops/min @ Rated pressure
<b>Weight</b>	0.29 kg [0.64 lb]
<b>Pilot ratio</b>	2.3:1
<b>Cavity</b>	<b>SDC16-3S</b>

Note: A piston seal requires a 4.5 bar [65 psi] or greater return spring.

#### DIMENSIONS

mm [in]

##### Cross-sectional view

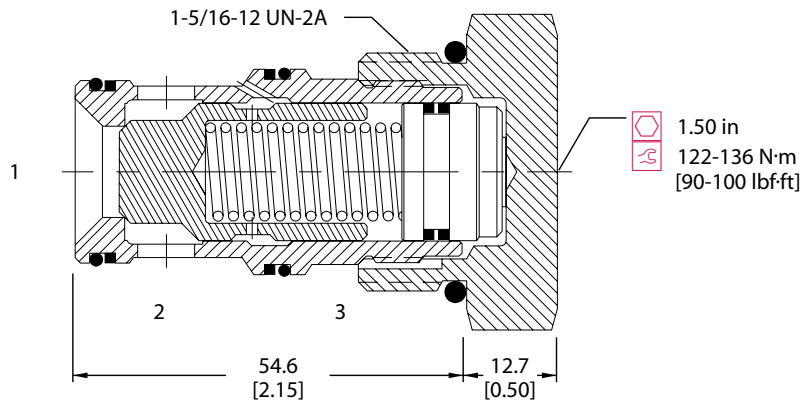

#### ORDERING INFORMATION

### CP462-1 - B - 16S - 065 - 0

##### Seal Option

Code	Seal Material	Seal kit
<b>B</b>	Buna	120033
<b>V</b>	Viton	120034

##### Piston Seals

Code	
<b>0</b>	No seals
<b>S</b>	Seals Included

Housings & Ports	Housing P/N
<b>0:</b> Cartridge Only	No Housing
<b>6B:</b> 3/4 BSP, AL	CP16-3S-6B/2B
<b>8B:</b> 1 BSP, AL	CP16-3S-8B/2B
<b>12S:</b> #12 SAE, AL	CP16-3S-12S/4S
<b>16S:</b> #16 SAE, AL	CP16-3S-16S/4S

Other Housings available

##### Crack Pressure

Code	bar	[psi]
<b>065</b>	4.48	[65]



# Pilot Operated Check Valves Technical Information

## Catalog HIC

### CP410-1

### OPERATION

This is a dual pilot operated check valve, which uses two CV10-NP check valves.

### Schematic

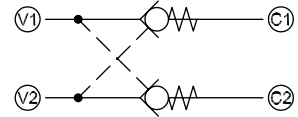

### SPECIFICATIONS

#### Theoretical performance

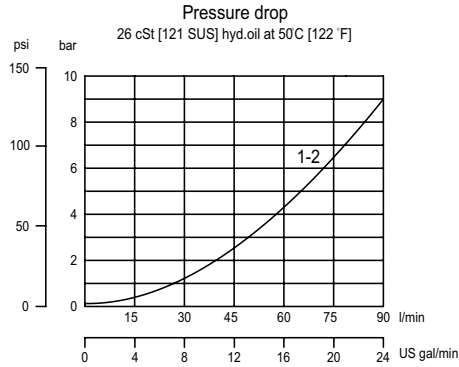

#### Specifications

<b>Rated pressure</b>	210 bar [3045 psi]
<b>Rated flow at 7 bar [100 psi]</b>	80 l/min [21.1 US gal/min]
<b>Leakage</b>	6 drops/min @ Rated pressure
<b>Weight</b>	0.67 kg [1.48 lb]
<b>Pilot ratio</b>	4:1
<b>Cavity</b>	none

Note: A piston seal requires a 4.5 bar [65 psi] or greater return spring.

### DIMENSIONS

mm [in]

#### Cross-sectional view

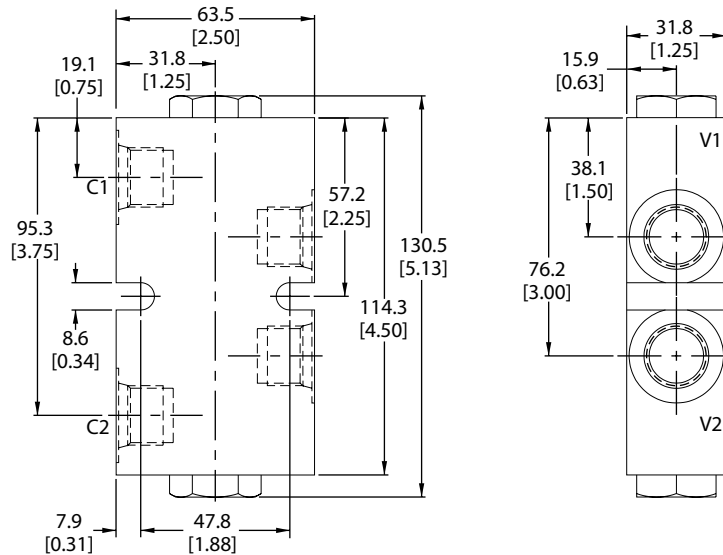

### ORDERING INFORMATION

CP410 - 1 - B - 8S - 0 - 065

#### Seals

	Seal kit	W/ piston seals
B = Buna-N	120072	120176
V = Viton	120161	120177

#### Crack Pressure

Crack Pressure	bar	[psi]
065	= 4.50	[65]

#### Housing and ports

	Housing P/N
6S = Aluminum, #6 SAE	220099
8S = Aluminum, #8 SAE	220100
3B = Al, 3/8 BSP	221794
4B = Al, 1/2 BSP	221652

#### Piston seals

0 = No seals  
S = Seals included