



## Directional Control Valves

DG3V-8/DG5V-8 Hydraulic/Solenoid Pilot Operated

# Contents

---

Section I. Introduction .....	3
Model Code Breakdown .....	4
Section II. Description .....	6
Section III. Valve Operation .....	7
Section IV. Pilot Valve Section .....	14
Section V. Internal Valve Functions .....	17
Section VI. Installation .....	18
Section VII. Service, Inspection & Maintenance .....	19
Section VIII. Overhaul .....	20
DG5V-8-S/H-*(C)-10 .....	20
DG3V-8-*(D) (2/8 / 28)-10 .....	21
DG4V-3(S)-*A(L)/B(L)-FJ/FW-60 .....	21
Section IX. Internal Body Passages & Plug Locations .....	28
Section X. Start-Up and Test .....	31

# Section I. - Introduction

## A. Purpose of Manual

This manual describes operational characteristics, maintenance requirements, and overhaul information for Vickers by Danfoss DG3V-8 and DG5V-8 series single stage and two stage pilot operated and hydraulic operated directional valves. The information contained herein pertains to the latest design series as listed in Table 1.

## B. Related Publications

Service parts and installation dimensions are not contained in this manual. The parts and installation drawings listed in Table 1 are available from any Vickers by Danfoss sales engineering office

## C. Model Codes

Variations within each basic model series are covered in the model code. See Table 2. Each unit has a model code marked on the main stage nameplate. Service inquiries should always include the complete model number as noted on the nameplate.

Model Description	Application Drawing	Parts Drawing
DG3V-8*A	5007.02/EN/0196/A	5007.03/EN/0496/S
DG3V-8*C		
DG3V-8*D		
DG5V-8*A		5007 04/EN/0496/
DG5V-8*B		
DG5V-8*C		
DG5V-8*D		
DG5V-8*F		
DG5V-8*N		

Table 1. Related Publications

# Model Code

(F\*) - DG5V - 8 - \* - (R) - (B) - \* \* (L) - (\*\*) - (X) - (\*) - (E) - (T) - (\*) -

1  
 2  
 3  
 4  
 5  
 6  
 7  
 8  
 9  
 10  
 11  
 12  
 13  
 14  
 15

- |  |   |   |
|--|---|---|
| <p><b>1</b> Special Seals<br/>(Omit if not required)<br/>F3 - Seals for fire resistant fluids<br/>F6 - Seals for water glycol</p>  | <p><b>8</b> Spool/Spring Arrangement<br/>A - Spring offset to 'A' port<br/>B - Spring centered with solenoid 'A' removed<br/>C - Spring centered<br/>D - Pressure centered<br/>F - Spring offset to 'A' port, shift to center<br/>N - No-spring detented (pilot valve only)</p>   | <p><b>12</b> Spool Control Modifications<br/>(Omit if not required)<br/>1 - Stroke adjustment (both ends) (not available on D models)<br/>2 - Pilot choke adjustment (available on all models)<br/>3 - Pilot choke and stroke adjustments (both ends) (available on D models)<br/>7 - Stroke adjusters on 'A' port end only (not available on D models)<br/>8 - Stroke adjusters on 'B' port end only (available on all models)<br/>27 - 2 and 7 combined (not available on D models)<br/>28 - 2 and 8 combined (available on all models)</p> |
| <p><b>2</b> Directional Control Valve<br/>DG5V - Subplate mounting; solenoid controlled; pilot operated. Pressure rating 350 bar (5000 psi) for all ports.</p>   | <p><b>9</b> Left Hand Build<br/>L - Single solenoid models only, omit if not required.</p>  | <p><b>13</b> External Pilot Pressure<br/>E - External pilot pressure. Omit for internal pilot pressure models.</p>  |
| <p><b>3</b> Valve Size<br/>8 - Valve size CETOP 8, NFPA D08</p>  | <p><b>10</b> Manual Override Options<br/>CETOP 3 piloted models only, omit if not required.<br/>Blank - Plain override in solenoid ends only<br/>H - Waterproof override in solenoid ends only<br/>H2 - Waterproof override in both ends of single solenoid<br/>P2 - Plain override in both ends of single solenoid<br/>Y - Lockable manual override in solenoid ends only (DC models only)<br/>Z - No override in either end</p> | <p><b>14</b> Internal Pilot Drain<br/>T - Internal pilot drain to 'T' port. Omit for external pilot drain models.</p>   |
| <p><b>4</b> Pilot Valve Type<br/>H - CETOP 3 High performance<br/>S - CETOP 3 Standard performance</p>   | <p><b>11</b> Fast Response<br/>X - Not available for pilot pressures above 210 bar (3000 psi). (Omit for standard internal pilot pressure models)</p>   | <p><b>15</b> Check Valve in Pressure Port<br/>Omit if not required.<br/>K - 0,3 bar (5 psi) check<br/>Q - 2,5 bar (35 psi) check<br/>R - 3,5 bar (50 psi) check<br/>S - 5,0 bar (75 psi) check</p>  |
| <p><b>5</b> Reducer Module<br/>(Omit if not required)</p> <p style="text-align: center;"><b>WARNING</b></p> <div style="display: flex; align-items: center;"> <p>When the standard performance pilot is selected, the reducer module is required to limit high drain line pressure transients generated during shifting.</p> </div>  |   |   |
| <p><b>6</b> Gauge Ports<br/>Blank - .4375-20 UNF-2B Thread<br/>B - 1/4 BSP Thread</p>  |   |   |
| <p><b>7</b> Spool Types<br/>0 - Open to T all ports<br/>1 - Open P&amp;A to T, closed B<br/>2 - Closed to T all ports<br/>3 - Closed P&amp;B, open A to T<br/>4 - Tandem P to T, closed crossover<br/>6 - Closed P only, open A&amp;B to T<br/>7 - Open P to A&amp;B, closed T<br/>8 - Tandem P to T, open crossover<br/>9 - Open to T all ports over tapers<br/>11 - Open P&amp;B to T, closed A<br/>31 - Closed P&amp;A, open B to T<br/>33 - Closed P, open A&amp;B to T over tapers<br/>52 - Closed center, regen. by sol. 'A'<br/>521 - Closed center, regen. by sol. 'B'</p> |   |   |

# Model Code (continued)

**(V) M - (S\*) - \* \*\* \* \* (L) - (\*) - \*\* - (\*\*\*) - 10 - (EN\*\*\*)**

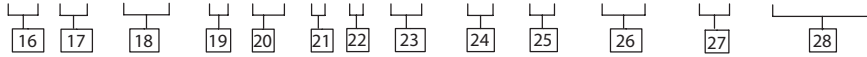

**16 Solenoid Energization Identity**

Blank - Standard arrangement for ANSI B93.9 (i.e. energize solenoid A to follow flow P to A).

V - Solenoid identification determined by position of solenoid (i.e. solenoid A at port A end/solenoid B at port B end).

**Note**

4 and 8 type spools are always V. Solenoid energization identity is independent of mainstage porting.

**17 Heading Electrical Flag Symbol**

M - Features and options for pilot valve.

**18 Pilot Valve Monitoring Switch**

(Omit if not required)

S3 - Limit switch normally open, wired to electrical connector with AC w//PA5 (H piloted models only)

S4 - Limit switch normally closed, wired to electrical connector with AC w//PA5 (H piloted models only)

S5 - Limit switch - unwired (H piloted models only)

S6 - Position switch with DC w/U coils (H piloted models only)

**19 Coil Type**

F - Flying lead (required for wiring housing option)

KU - Top exit flying lead

P - Plug in

SP1 - Single 6.3mm spade

SP2 - Dual 6.3mm spade

U - ISO 4400 (DIN 43650)

X1 - Flameproof solenoids

BASEEFA/CENELEC

(S piloted models only)

X2 - Explosion proof solenoids CSA/UL (S piloted models only)

X3 - Explosion proof solenoids BASEEFA ExS

(S piloted models only)

**20 Electrical Connections**

(F type coils only, omit if not required)

PA - Insta -plug, male receptacle only

PB - Insta -plug, male and female receptacle

PA3 - 3-pin connector

PA5 - 5-pin connector

T - Wired terminal block (wiring housing option also required)

**21 Wiring Housing**

W - 1/2" NPT threaded connection

J - 20mm threaded connection

G - 1/2" BSPP threaded connection

**22 Electrical Options**

(Omit if not required)

U-type coils only

1- Fitted connector

2- Fitted connector and variable grommet

6- Fitted connector with lights

**23 Solenoid Indicator Lights**

(Omit if not required)

**24 Surge Suppressor/Damper**

(DC voltages only, omit if not required)

D1- Encapsulated diode (industrial applications)

D2- Encapsulated diode (mobile applications)

D7- Encapsulated transzorb

**25 Coil Voltage Identification Letter**

**26 Pilot Valve Port Orifices**

(Omit if not required)

**27 Design Number**

**28 Special Modifications**

(Omit if not required)

## Section II. - Description

---

### A. General

Directional valves are devices used to change the flow direction of fluid within a hydraulic circuit. A valve is designed to control the direction of movement of a work cylinder or the direction of rotation of a fluid motor.

### B. Basic Four-Way Sliding Spool Directional Valve Construction

Vickers valve bodies have a precision machined bore in which a very close tolerance spool is suspended on a film of hydraulic fluid. Spool lands and body cavities are designed to divide the bore openings into separate chambers. Ports in the body lead into these chambers so that spool position determines which ports are open or closed. See Figure 1. Oil flow is directed from one port to another within the body and out of a port to the work

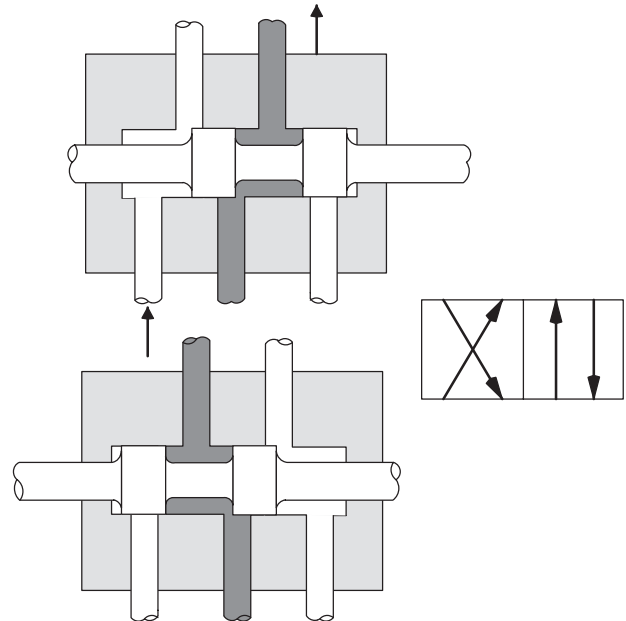

Figure 1. Spool Type Four-Way Valve

---

### C. Two Stage Directional Valve Construction

Two stage directional valves are pilot pressure operated. A two stage valve is constructed by combining a pilot valve and a larger main stage valve into one assembly. A DG4V-3(S) pilot valve is mounted on top of the main stage valve. When a pilot valve solenoid is energized (activated), the pilot spool moves and fluid is diverted to the mainstage; thus controlling main stage spool movement. Figure 2 illustrates the basic construction of a two stage, pilot operated directional valve.

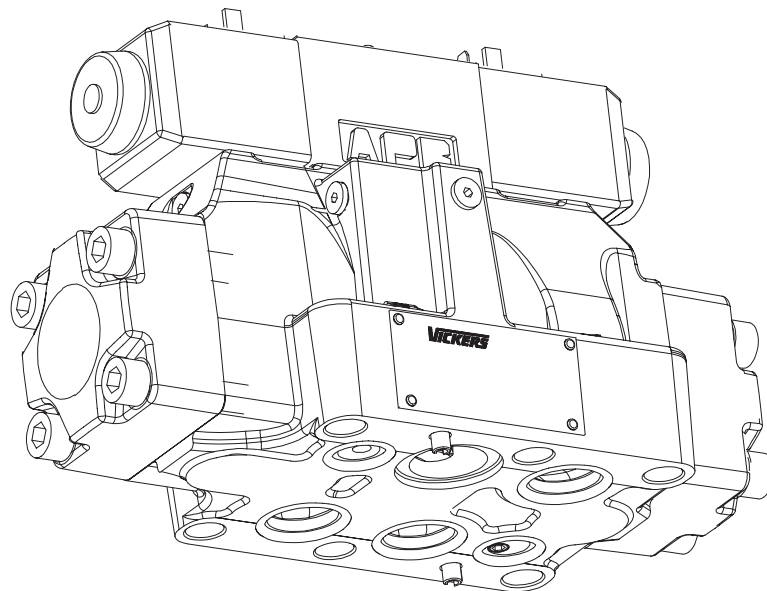

Figure 2. Typical 'DG5' Type Solenoid Controlled, Pilot Operated Valve

---

# Section III. - Valve Operation

## A. General

Directional valve operation is determined by four factors: spool type, spool positioning, method of control, and special features. Proper selection of the above factors establish and regulate desired flow paths through the internal ports of the valve. The following information discusses those factors with respect to valve operation.

## B. Spool Types - Main Stage Section

Operation of spools are governed by their design as well as the means of control. The most common designs are open center, closed center and tandem. During the following discussion, basic spool design is related to valve port openings, with the spool in center position. Port openings are stated as: P-Pressure Port, A&B-Actuator Ports, and T-Tank or Reservoir Port.

1. Open Center Spools (0, 1, 9 and 11 types): Open center valves are used in single operations where no other operation is performed by the same source of power and where cylinders do not have to be held by pressure. Open center spools are also used to minimize shock in a system. Shock develops when a valve spool is shifted from one position to another across center position. The smoothest possible minimum shock condition is obtained when fluid under pressure is allowed to discharge to tank as the spool passes center condition.

Open center with (A) or (B) ports blocked. A spool of this type is generally used to operate a cylinder. When the spool is centered, a cylinder port is blocked and the cylinder is held in a definite position. In some circuits, flow from the tank port is piped into the pressure port of another valve. This allows the same source of power to operate two different cylinders. This type of arrangement may be used in a system containing a number of operations. However, each operation must be performed in a certain sequence, with only one operation taking place at any one time.

A. Type '0' spool is designed with ports (P), (B), (A) and (T) interconnected when the spool is in center position. These ports are momentarily interconnected during spool crossover when the pilot valve solenoid is activated. This permits smooth rapid cycle operation.

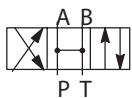
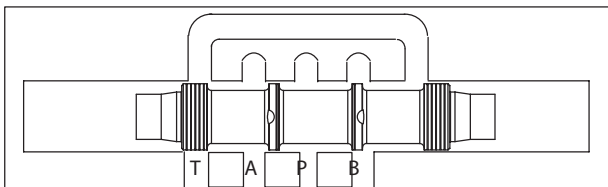

Open Center

B. Type '1' spool is designed with ports (P), (A) and (T) interconnected. Port (B) is blocked in center position.

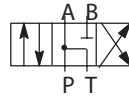
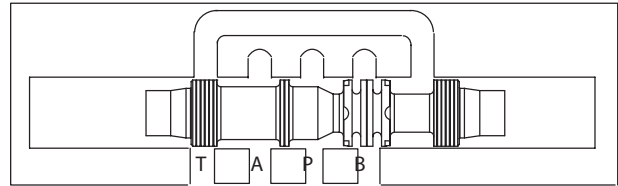

"B" Closed - Pressure Open to Tank through "A"

C. Type '9' spool is similar to type '0' spool except all ports are partially open in center position.

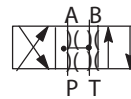
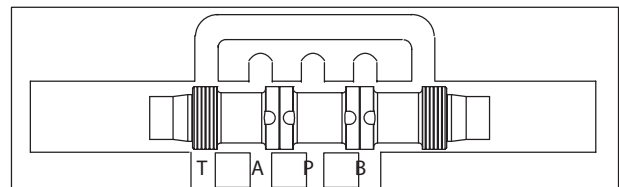

Open Center, Partial, All Ports

D. Type '11' spool is a type '1' spool reversed in the bore. The type '11' spool interconnects (P), (B) and (T) in center position with (A) blocked.

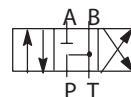
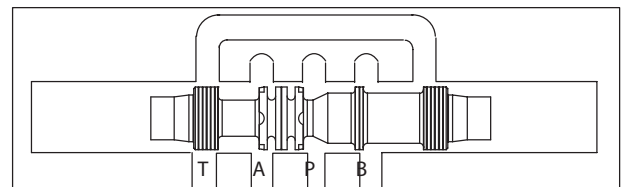

"A" Closed, Pressure Open to Tank through "B"

2. Closed Center Spools (2, 3, 6, 31, 33, 52 and 521 types):  
 Closed center spools are used where two or more operations are performed by a single pump or an accumulator. Closed center valves prevent the loss of fluid from the pump or accumulator when the spool crosses center.

A. Type '2' spool blocks ports (P), (A), (B) and (T) from one another in the center position. The ports are momentarily blocked during spool crossover.

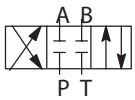
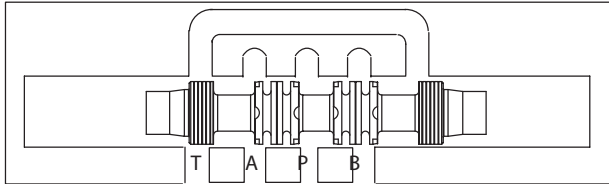

Closed Center  
 - All Ports Closed

B. Type '3' spool is designed with ports (A) and (T) interconnected and ports (P) and (B) blocked in the center position.

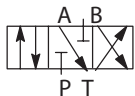
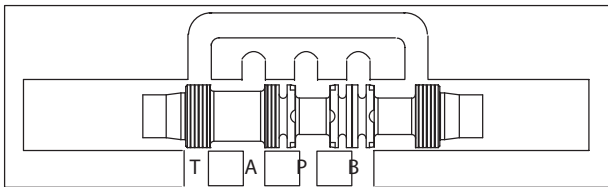

Pressure and "B" Closed -  
 "A" Open to Tank

C. Type '6' spool is interconnected at ports (A), (B) and (T). Port (P) is blocked in the center position.

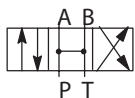
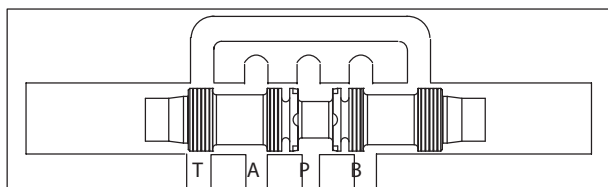

Pressure Closed -  
 "A" & "B" Open to Tank

D. Type '31' spool is a type '3' spool reversed in the bore. A type '31' spool is interconnected at ports (B) and (T), but blocked at ports (P) and (A) in the center position.

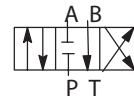
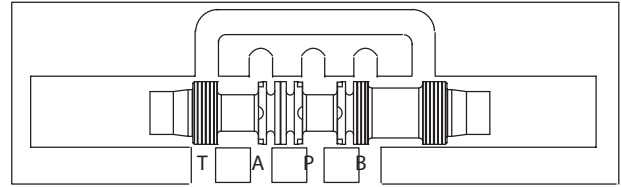

Pressure and "A" Closed  
 - "B" Open to Tank

E. Type '33' spool provides controlled leakage from port (A) and (B) to port (T). Port (P) is blocked in the center position.

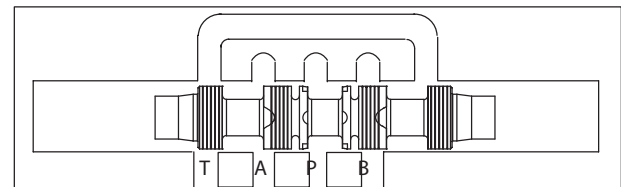

Closed Center  
 - Bleed "A" & "B"

F. Type '52' spool

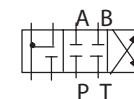
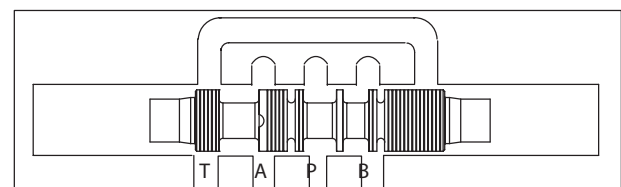

Closed Center,  
 Regen. by Solenoid 'A'

G. Type '521' spool

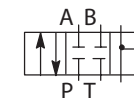
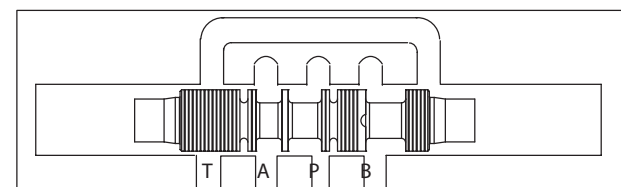

Closed Center,  
 Regen. by Solenoid 'B'

3. Tandem spools (4 and 8 types): Tandem spool valves are used in hydraulic circuits where two or more hydraulic cylinders or motors are controlled from a single source of power. The valve's spool is designed so that in center position, all cylinder connections are blocked and full pump delivery is connected to tank. The tank connection of one valve may be connected to the pressure connection of another valve and both valves operated simultaneously as long as the combined pressures developed by the two loads are within the capabilities of the power source.

A. Type '4' spool allows oil to circulate freely from port (P) to port (T) in the center position. Ports (A) and (B) are blocked to the workload.

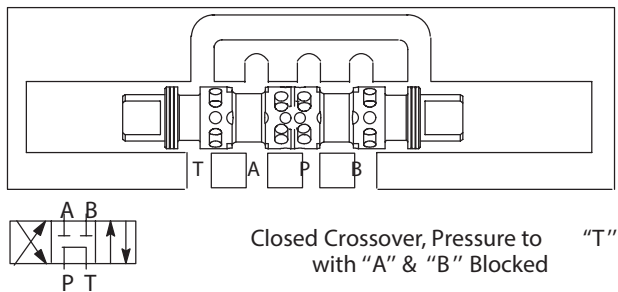

B. Type '8' spool is designed similar to type '4' spool. Ports (P) and (T) are connected in the center position. However, ports (A) and (B) are momentarily open during spool crossover.

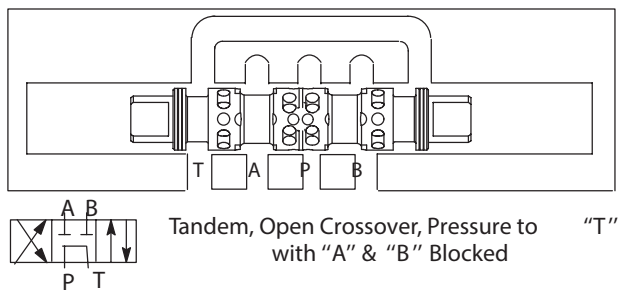

### C. Methods of Spool Control, Main Stage

1. Remote Pilot Source: Main stage valves are available for use with a remote source. This means that the valve is shifted from a remote pressure source by other valves in the logic circuit.
2. Integral Pilot Valve: The integral pilot type two stage valve is a very common valve used in the field today. Two stage valves allow large volumes of fluid to be switched to and from an actuator with minimum power required for control. Reference figures 3 through 7 shown in the following section.

### D. Main Stage Spool Position

Main stage spools are positioned within the valve by special arrangements. The four basic main stage positioning arrangements are: no spring-floating, spring centered, spring offset and pressure centered.

The following paragraphs (1 through 4) describe these arrangements. A fifth function can be obtained by the use of a detent pilot valve. This function is described in paragraph five.

1. No Spring-Floating: When centering springs are omitted from the main stage spool, the spool is said to be floating. If control pressure is removed, a floating spool can move from its last position under the influence of gravity or tank line pressure. This must be considered during the design of the system. Units with floating type spools have the model code letter omitted. Figure 3 illustrates floating spool positioning in a two-stage valve.

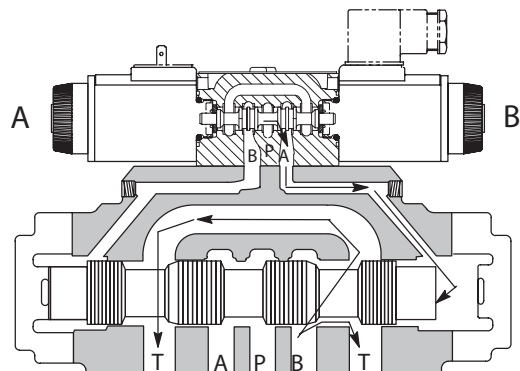

1. Solenoid "A" is energized and shifts pilot spool to the right. This opens pressure to pilot port "A" and the main stage spool.
2. When solenoid "A" is energized, the main stage spool will shift left. Flow from P → A and B → T is obtained.
3. Main stage spool will stay in this position until solenoid "B" is energized, but may float to other positions with both solenoids de-energized.

Figure 3. No Springs, Floating Model

2. Spring Centered: A spring and washer arrangement is used on both ends of the main stage spool in the spring centered configuration. If control pressure is removed from a spring centered spool, the valve will go to the center position due to spring force. Two configurations of a two-stage spring centered valve can be obtained, a type 'B' and a type 'C'. If one solenoid is used on a spring centered pilot valve, the model code is identified with the letter 'B'. When two solenoids are used, the model code is identified with the letter 'C'. Figure 4 illustrates spool positioning of a two-stage spring centered 'C' model.

3. Spring Offset: Single stage spring offset models use one spring to return the spool to an offset position. In two-stage models, the spring and washer is removed from the main stage and offset action is obtained from the pilot valve. Spring offset pilots control the main stage when the solenoid is de-energized, through spring action, so long as pilot pressure is available. Spring offset valves have the letter 'A' stamped into the nameplate. Figure 5 illustrates an offset two-stage valve.

4. Pressure Centered: Pressure centered valves provide more positive centering arrangement than normal spring centered valves. This is accomplished in the following manner:

Assume both pilot valve solenoids are de-energized and the main stage spool is positioned to the left (see Figure 6). Pilot pressure is applied to both ends of the main stage from the number seven (7) pilot spool. The sleeve moves to the right under the influence of the spring and pilot pressure until the position shoulder is contacted. Since the sleeve and piston areas are greater than the total spool area at the right hand end of the valve, the sleeve continues to move to the right carrying the piston with it until it contacts the valve body (center position).

**WARNING**

Loss of pilot pressure will not guarantee spool position.

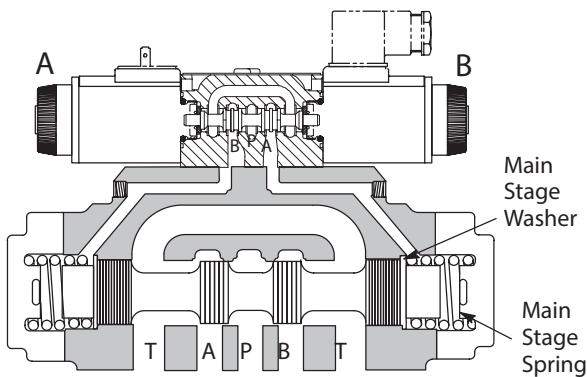

1. Solenoids are de-energized. Pilot spool is in center position due to spring force. Flow is A & B → T with → P blocked.
2. Main stage springs and washers keep main stage spool at center position. When solenoid "A" is energized, the pilot spool will shift to the right, causing the main stage spool to shift left. Main stage flow would then be P → A and B → T.

Figure 4. Spring Centered "C" Model

Assume the main stage spool was positioned to the right with both pilot valve solenoids de-energized, pilot pressure is applied to the sleeve and piston areas on the left side but the sleeve is bottomed against the valve body at this time. Only the piston area applies force to the left end of the spool. Since the spool land area at the right side is greater than the piston area, the spool will be forced to the left until the piston shoulder butts against the sleeve (center position).

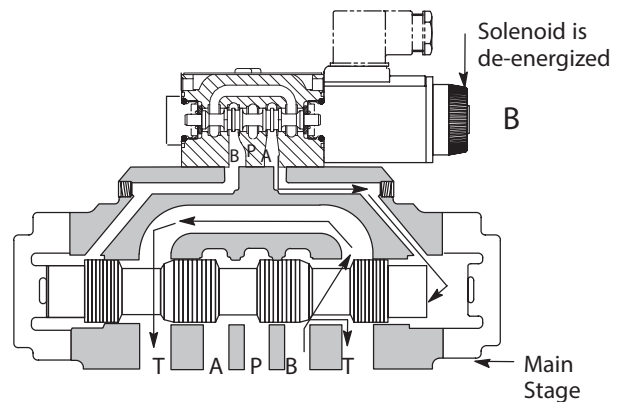

The spring returns pilot spool to "A" offset position and shifts main stage spool. Main stage oil flow is P → A and B → T.

Figure 5. Spring Offset "A" Model

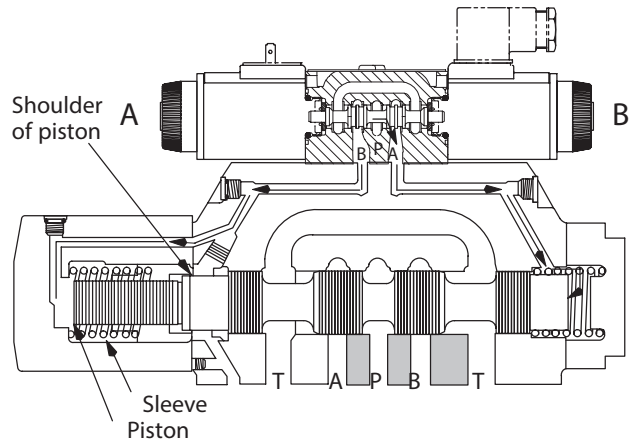

1. Solenoids are de-energized. Pilot spool is in center position. (P → A & B, T blocked) (shown).
2. Pilot pressure keeps main stage spool in center position. Flow is blocked to all ports.
3. When solenoid "B" is energized, the pilot spool shifts to the left. Oil under pressure enters piston area causing the main stage spool to shift to the right. Main stage flow from P → B and A → T is obtained.

Figure 6. Pressure Centered "D" Model

If pilot pressure falls below 20 bar (300 psi), the centering springs will cause the spool to center within the valve body.

Pressure centered models have the letter 'D' stamped into the unit nameplate. Figure 6 illustrates spool/spring arrangements on pressure centered models.

**Note**

A fifth condition of the main stage spool can be obtained through the use of a detent pilot stage. Refer to the following paragraph.

5. Detent Valve Operation: Detent valve operation can be achieved by installing a detent into the pilot valve. A detent is assembled on one or both ends of the pilot spool depending on the type of pilot valve used. When a pilot valve solenoid is de-energized, the detent holds the pilot spool in the last position attained and the main stage spool remains in its last position.



**WARNING**

If pilot pressure fails or falls below the minimum requirement of 5 bar (75 psi), the main stage spool will shift to center position even though the pilot valve remains in the last detent position. For this reason, flow conditions in center or neutral position must be selected with care.

Detent models are indicated by the letter 'N' stamped into the unit nameplate. Figure 7 illustrates the spool/spring arrangement on detent models.

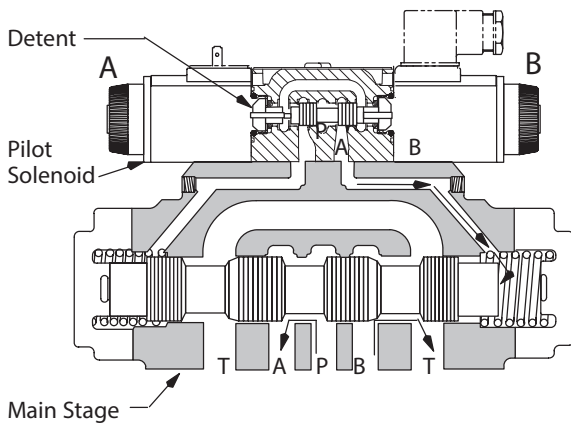

1. Solenoid "A" is energized and shifts pilot spool to the right.
2. Which causes main stage spool to shift left. Oil flow from P → A and B → T is obtained.
3. Main stage spool remains in position attained due to pilot valve detent until solenoid "B" is energized. (Note: If pilot pressure fails, the main stage will shift to center position.)

Figure 7. Detented "N" Model

**E. Optional Features (Main Stage)**

Control of the mainstage spool travel can be modified with certain optional features. The most common features are discussed in the following paragraphs.

1. Stroke Limiter Adjustment (Fig. 8): Main stage spool travel can be limited by using stroke adjust covers. Stroke adjust covers may be used on one or both ends of the main stage section. When the stroke is limited, maximum flow through the valve is reduced (assuming same inlet pressure). This slows the actuator movement. To limit the spool travel, loosen the jam nut and turn adjusting screw clockwise.

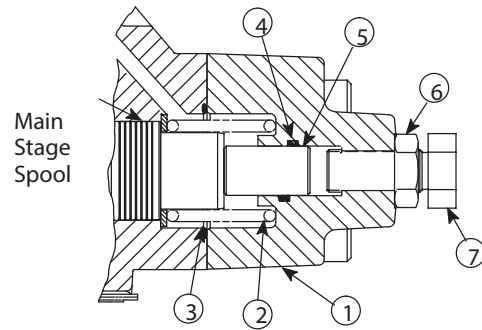

Part No.	Part Name	Part No.	Part Name
1	Cover	5	Piston
2	Spring	6	Jamnut
3	O-Ring	7	Adjuster Screw
4	Back-up Ring		

Figure 8. Stroke Adjuster Feature

2. Pilot Choke Option (Fig. 9): A pilot choke increases the amount of time it takes to shift the main stage spool from one position to another. Increasing shift time lowers the possibility of developing large flow transients in the circuit. A pilot choke is designed to allow free flow to one end of the main stage spool but restricts flow out of the opposite end. The rate of spool travel, in either direction, can be slowed by loosening a locknut and turning an adjusting screw clockwise. To increase the rate of spool travel, turn the adjusting screws counterclockwise. When a pilot choke is used, pilot pressure should be taken from a constant pressure source. The pilot choke is mounted between the pilot valve and the main stage sections.

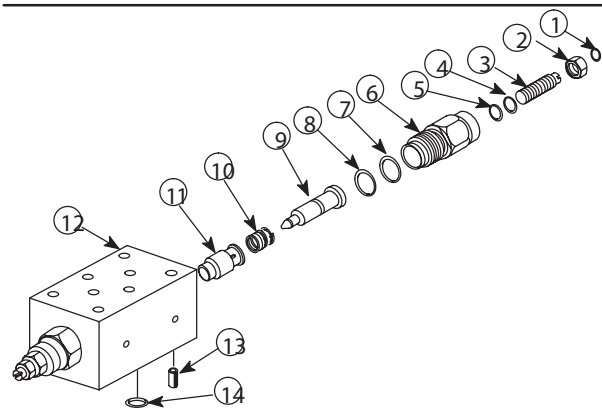

Part No.	Part Name	Part No.	Part Name
1	Retaining Ring	8	Back-up Ring
2	Nut	9	Needle
3	Adjusting Screw	10	Spring
4	"O" Ring	11	Sleeve
5	Back-up Ring	12	Body
6	Needle Housing	13	Dowel Pin
7	"O" Ring	14	"O" Ring

Figure 9. Pilot Choke

3. Reducer Module (Fig 10): The reducer module is required for piloted models when pilot pressure exceeds 210 bar (3000 psi). These two-stage spool valves maintain a reduced outlet pressure against variations in inlet pressure. These valves are able to act as relief valves (at 50% of the maximum flow) to prevent excess pressure being developed when an actuator is subject to a reactive load.

4. Fast Response Option: Some applications require the main stage spool to shift at a faster than normal rate. For such applications, the fast response option is used. This option requires the removal of an orifice plug within the main stage body. When the orifice plug is removed, larger volumes of fluid will enter the pilot valve section. When the pilot valve shifts, the main stage spool responds at a faster rate. However, this also generates transients that increase system shock. For this reason, the fast response option is not recommended when pilot pressures exceed 210 bar (3000 psi). Fast response models have the letter "X" stamped into the unit nameplate (i.e. DG5V8-\*\*X-\*\*-M-\*\*-10). Refer to catalog 5007.02/EN/0196/A for response time data. Figures 20 and 21 show the location of the orifice plugs that must be removed for the fast response option.

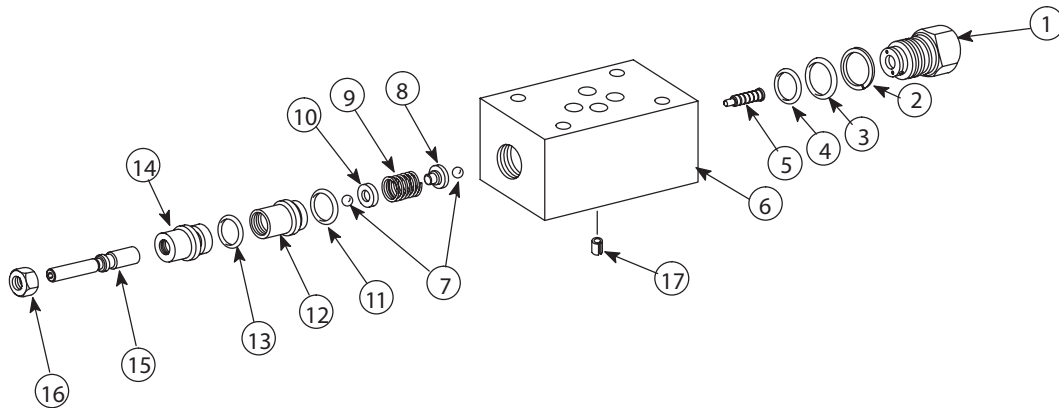

Part No.	Part Name	Part No.	Part Name
1	Plug	10	Spring Rest
2	Back-up Ring	11	"O" Ring
3	"O" Ring	12	Spring Housing
4	"O" Ring	13	"O" Ring
5	Spool	14	Adjuster Housing
6	Body	15	Adjuster
7	Ball (2)	16	Nut
8	Spring Rest	17	Dowel Pin
9	Spring		

Figure 10. Reducer Module

# Section IV - Pilot Valve Section

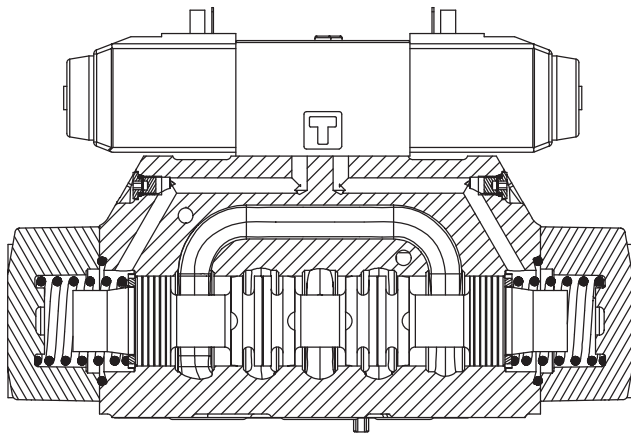

Figure 11. DG5V8 with DG4V-3(S) Pilot

## A. Spool Type - Pilot Valve Section

To maintain proper control, closed center pilot spools are normally used in two stage valves. In most cases, a number "6" type pilot spool is used.

When a type "4" or "8" main stage spool is used, the letter "V" is inserted into the pilot valve model code.

## B. Spool Positioning - Pilot Valve Section

Pilot spools are positioned within the valve by special spool arrangements. The three basic pilot valve spool arrangements are spring centered, spring offset and detents. The following paragraphs (1 through 3) describe pilot spool arrangements.

1. Spring Centered: A spring and washer are installed at each end of the pilot valve spool. The spring moves the spool until the washer contacts the end of the valve body. In the deenergized condition of the pilot valve, the spool is held in center position within the body by the springs and washers.

2. Spring Offset: Spring offset models use one spring and washer to return the pilot valve spool to an offset position. In this model, a solenoid is completely removed from the spring end of the pilot valve.

3. Detents: A detent mechanism is installed on one or both ends of the pilot valve spool. Detent valve solenoids can be momentarily energized to the correct position and then power may be removed from the solenoid. The detent(s) hold the pilot spool in the last position attained until the opposite solenoid is energized.

## C. Methods of Control - Pilot Valve

The following pilot control methods are available for pilot spool position.

Control	Model Codes
Electrical Solenoid	DG4V-3, DG4V-3S

1. Remote Pilot: Pilot valves, such as a DG4V-3, are available for use with a remote pilot source. This means that a valve can be shifted from a remote pressure source by other valves in the logic circuit. Refer to service parts drawing 5007.04/EN/0496/S.

2. Electrical Solenoid Pilot Operation: Electrical solenoids are attached to the pilot valve body. Internal push pins connect the solenoid to the pilot spool. When the magnetic field of solenoid "B" is energized, the solenoid armature moves the push pin and shifts the pilot spool towards solenoid "A" (see Figure 12a). When solenoid "A" is energized, the pilot spool shifts toward solenoid "B" (see Figure 12b). When both solenoids are de-energized, the pilot spool shifts to center position (see Figure 12c).

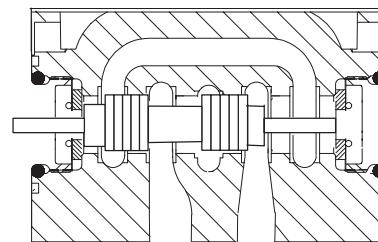

Figure 12a. Flow Conditions  
Pressure to "B" - "A" to Tank

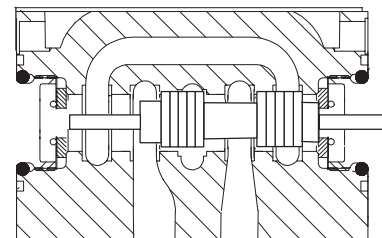

Figure 12b. Flow Conditions  
Pressure to "A" - "B" to Tank

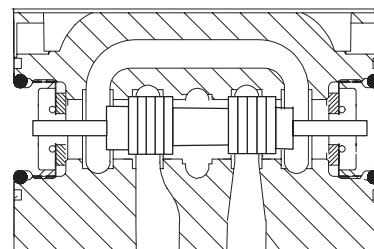

Figure 12c. Flow Conditions  
Flow Blocked (Center Condition #2 Spool)

### CAUTION

DO NOT energize both (AC) solenoids simultaneously. Sustained operation with both solenoids energized will cause excessive current in the coil and accelerates burnout.

A. Electrical Solenoid Types Available: Two basic types of electrical solenoids exist: Standard and high performance. The unit nameplate identifies the type of solenoid being used. See the model code in Table 2.

B. Electrical Solenoid Voltage Requirement: Electrical solenoids are available in various AC and DC voltage ranges. The standard voltage and frequency range is 115V AC, 60 Hz. Refer to parts and service drawings for units with non-standard voltage ranges. Ten (-10) design units use an identification letter for the coil voltage and frequency.

C. Electrical Solenoid Ground Connections and Wiring Housing: An electrical wiring housing with a  $\frac{1}{2}$ " NPTF thread connection is available on DG4V-3 pilot valves. Wire grounding screws are provided for convenience.

D. Manual Override: Each solenoid has a manual override plunger to shift the pilot spool. This feature allows a technician to shift the pilot spool when electricity is not available. Refer to Figure 13. To operate the manual override feature, obtain a small rod and push in on the plunger.

5. Accessories for Electrical Type Solenoids: The model code (Table 2) indicates the type of accessories used on directional valves. Obtain a parts and service drawing for your particular model (see Table 1). Most accessories pertain to the pilot section. The most common types of accessories are discussed in the following paragraphs (A through F).

A. Hazardous Location Solenoids: This type of is used at locations where added protection from electrical shortage failure is mandatory, the solenoid housing is designed to completely enclose all wiring connections to the valve. Hazardous location valves are approved Class 1, Group D or Class 2, Group E-F-G, for 1 various voltages.

B. Monitor (Limit) Switch Feature: The monitor switch feature can be incorporate into a basic spring offset directional valve. The switch monitors valve spool position and an be wired into control circuits. This permits electrical interlocking of various hydraulic controlled motions without resorting to external mechanical arrangements. The monitor switch is a single pole, double throw contact arrangement with -normally closed and - normally open connections. Switch ratings are noted on installation drawing (Table 1). The monitor switch housing does not provide a manual plunger for operation of the switch or valve.

C. Insta-Plug Connectors: Pilot valves can be supplied with electrical connectors called insta-plugs. These connectors allow quick disconnect of electrical power from the valve. The following data pertains to the insta-plug feature:

PA- A prefix of PA in the model code indicates the male plug section of the insta-plug feature is included on the valve.

PB- A prefix of PB in the model code indicates both the male plug and female receptacle are included with the valve. the insta-plug feature is available on the DG4V-3(S) directional valves.

#### Wiring Note

Connect white wires to "A" solenoid and black wires to the "B" solenoid. Refer to parts drawing (Table 1) for additional data.

D. Brad Harrison Connectors: Brad Harrison connectors thread into the  $\frac{1}{2}$ " NPTF opening in the wiring housing of a DG4V-3(S) directional valve.

PA3- A prefix of PA3 in the model code indicates the three pin male connector is included with the valve.

PA5- A prefix of PA5 in the model code indicates the five pin male connector is included with the valve.

Female Brad Harrison connectors are not available from Vickers and must be supplied by the customer.

E. Solenoid Indicator Lights: Solenoid indicator lights are available for installation on the DG4V-3(S) series directional valves. Indicator lights are connected across the solenoids and will light when voltage is present at the solenoid. This gives an indication to the technician which solenoid is energized and aids in troubleshooting a system. Refer to the appropriate parts drawing for additional information.

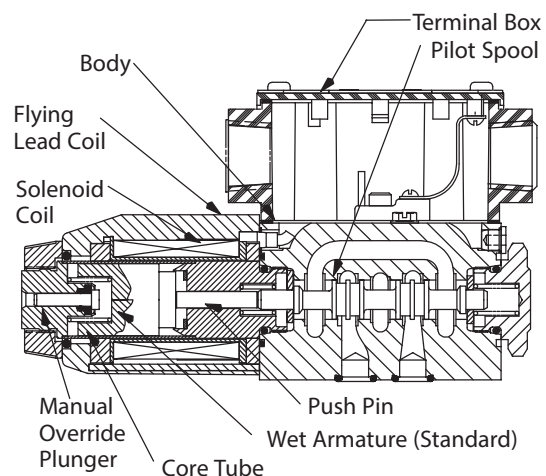

Figure 13. Typical DG4V-3(S)-C-FW-60

# Section V - Internal Valve Functions

## A. General

To insure the proper application of a two stage valve, pilot pressure, pilot drain and integral check valve options must be considered. The following paragraphs (B through D) discuss these options.

## B. Pilot Pressure

1. **Internal Pilot Pressure (Standard):** Internal pilot pressure can be obtained in two ways and must be tailored for the application. Models with closed center type spools automatically provide internal pilot pressure. Models that use open center spools require a check valve in the pressure (P) port to maintain minimum pilot pressure. In most cases, maximum internal pilot pressure is rated to 210 bar maximum (3000 PSI). Minimum pilot pressure ratings are noted in the installation drawings (see Table 1).

2. **External Pilot Pressure:** When pilot pressure from a separate source is used, it must be connected to the "X" port (external pilot pressure connection). Models that use external pilot pressure do not require a check valve at the pressure port. External pilot pressure models are identified with the letter "E" stamped in the unit nameplate (i.e. DG5V-8-S-2C-\*-E-M-\*-10). See installation drawings for maximum external pilot pressure.

3. **Pilot Pressure Conversions:** If it is necessary to convert your unit from external pilot pressure to internal pilot pressure or vice versa, internal plug(s) must be removed or added to the main stage body. See the figures noted in installation plug tables for internal plug locations.

## C. Pilot Valve Drains

1. **Internal Drain:** Internal drain models are used when pressure surges in the tank line are small and CAN NOT overcome pilot pressure.

To shift a pilot spool, pilot pressure must always exceed tank pressure by a minimum amount. Figure 14 is an example showing pilot pressure vs. tank pressure. Refer to the unit installation drawing for minimum pressure ratings. Internal pilot drain models have the letter "T" stamped on the unit nameplate (i.e. DG5V-8-S-2C-\*-T-M-\*-10).

### Note

A 10 bar (150 PSIG)  $\Delta P$  must always be maintained to shift closed center spools. A 5 bar (75 PSIG)  $\Delta P$  must always be maintained to shift open center pilot spools.

2. **External Drain (Standard):** External drain models are recommended if pressure surges in the tank line CAN overcome pilot pressure. Drain connection "Y" is used for externally drained models. Pressure centered "D" models use two drain connections "Y" and "W". All external drain connections MUST be piped directly to tank through surge free lines. Refer to the installation drawing (Table 1) for further information.

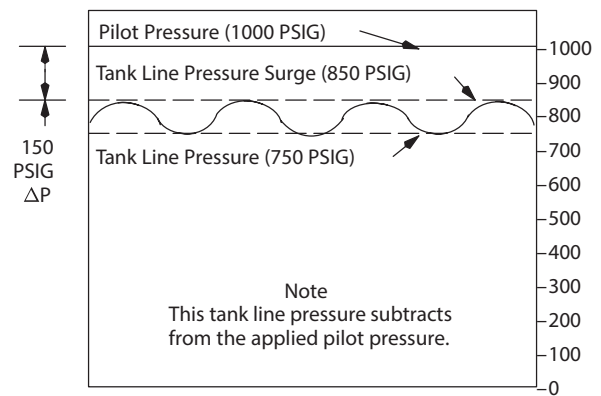

Figure 14. Pilot Valve-Internal Drain

3. **Drain Conversions:** If it is necessary to convert your unit from external drain to internal drain or vice versa, an internal "T" plug must be added or removed to the main body section. Figures 21 and 22 show internal "T" plug locations on various models.

## D. Integral Check Valves

Check valves are located within the pressure port of the main stage section. The purpose of the check valve is to develop back pressure, at the pressure port, when open center or tandem main stage spools are used. Back pressure is necessary to maintain internal pilot pressure when the main stage spool shifts to open center position. Table 3 indicates when an integral check valve is required.

Pilot Pressure Source	Integral Check Valve Required	Main Stage Spool Type
Internal	Yes	0, 1, 4, 8, 9, 11
	No	2, 3, 6, 31, 33
External	No	All spools

Table 3. Integral Check Valve Circuit Requirements

Integral check valves are available at various cracking pressure ranges. The unit nameplate identifies which check valve is used (i.e. DG5V-8-S-2C-\*-T-M-\*-10). Refer to installation drawing (Table 1) for additional check valve information.

### Note

As an alternate to the integral check valve, a 3.5/5 bar (50/75 PSI) check valve can be installed in the tank line of the valve to obtain pilot pressure.

# Section VI - Installation

## A. Installation Drawings

The installation drawings listed in Table 1 show installation dimensions, port locations and operating parameters. Manifold, subplate and bolt kit information is also included.

### Note

Detent valves must be installed with the valve spool in the horizontal position for good machine reliability. The mounting position of spring offset and spring centered models is unrestricted.

### Note

Make sure the "Y" drain port is piped directly to the tank. Back pressure cannot be tolerated at this valve port.

### CAUTION



On solenoid operated directional valves, ensure an electrical ground is connected to the valve. This prevents the possibility of a shock hazard if a coil develops a short circuit to the frame.

## B. Fluids and Seals

Standard seals (Nitrile) can be used with petroleum, water-glycols, and water-oil emulsion type fluids.

F1 seals (Butyl, EPR) must be used for alkyl phosphate-ester base fluids and aircraft type fire-resistant fluids. F1 seals cannot be used with petroleum or phosphate ester-hydrocarbon blends.

F3 seals (Viton ®) can be used with all commonly used industrial hydraulic fluids. Viton ® is compatible with petroleum, water-base and synthetic fire-resistant fluids.

® Viton is a registered trademark of E.I. Dupont

F6 seals (Nitrile) can be used with petroleum, water-glycols, and water-oil emulsion type fluids.

The following table summarizes the compatibilities of the most common phosphate ester fluids.

Fluid Type	F1	F3	F6
Skydrol	Yes	No	No
Pydraul 10-E	Yes	No	No
Pydraul 29-E-L-T, 50-E 65-E, 115-E	Yes	Yes	Yes
Pydraul 230-C, 312-C, 540-C	No	Yes	Yes
Fyrquel & Fyrlube	Yes	Yes	Yes
Fyrtek	No	Yes	Yes
Houghton Safe 1000 Series	Yes	Yes	Yes

## C. Piping and Tubing

1. All pipes and tubing must be thoroughly cleaned before installation. Recommended cleaning methods are sandblasting, wire brushing and pickling.
2. To minimize flow resistance and the possibility of external leakage, use only the necessary fittings and connections required for proper installation.
3. The number of bends in tubing should be kept to a minimum to prevent excessive turbulence and friction of fluid flow. Tubing must not be bent too sharply. The recommended radius for tube ends is three times the inside diameter.

## D. Hydraulic Fluid Recommendations

Hydraulic fluid within the systems performs the dual function of lubrication and transmission of power. To insure proper lubrication, system life, and component reliability, fluid selection should be made carefully with the assistance of a reputable supplier. Fluid selection should be acceptable for use with all valves, motors and pumps within the system.

The fluid recommendations noted in the data sheet are based on our experience in industry as a hydraulic component supplier. Where special considerations indicate a need to depart from these recommendations, see your Vickers sales representative.

## E. Cleanliness

To ensure your hydraulic system is clean, perform the following steps:

1. Clean (flush) the entire system to remove paint, metal chips, welding shot, etc.
2. Filter each oil change to prevent introduction of contaminants.
3. Provide continuous oil filtration to remove sludge, products of wear and corrosion generated during the life of the system.
4. Provide protection to all areas that can introduce airborne contaminants into the system.
5. Perform regular servicing procedures of filters, breathers, and reservoirs.

## F. Overload Protection

A relief valve must be installed in the system as close to the pump as possible. The relief valve limits pressure in the system to a prescribed maximum. The setting of the relief valve depends on the work requirements of the system.

# Section VII - Service, Inspection & Maintenance

## A. Service Tools

No special tools are required to service this valve series.

## B. Inspection

Periodic inspection of the fluid condition and tube or piping connections can save time consuming breakdown and unnecessary parts replacement. The following should be checked regularly.

1. All hydraulic connections must be kept tight. A loose connection in a pressure line will permit the fluid to leak out. If the fluid level becomes so low as to uncover the inlet pipe opening in the reservoir, extensive damage to the system can result. Loose connections also permit air to be drawn into the system resulting in a noisy and/or erratic operation.
2. Clean fluid is the best insurance for long service life. Therefore, check the reservoir periodically for dirt and other contaminants. If the fluid becomes contaminated, flush the entire system and add new fluid.
3. Filter elements should also be checked periodically. A clogged filter element will cause higher pressure drops within the system.
4. Air bubbles in the reservoir can ruin the valve and other components. If bubbles are seen, locate the source of the air and seal the leak.

## C. Adding Fluid to the System

When hydraulic fluid is added to replenish the system, pour it through a fine wire screen (200 mesh or finer). When applicable, pump the fluid through a 10 micron filter. DO

NOT use a cloth to strain the fluid or lint may enter the system.

## D. Adjustments

No periodic adjustments are required other than normal system maintenance,

## E. Replacement Parts

Reliable operation throughout the specified operating range is assured only if genuine Vickers parts are used. Sophisticated design processes and material are used in the manufacture of our parts. Substitutions may result in early failure. Part numbers are shown in the parts and service drawings listed in Table 1.

## F. Product Life

The service life of this product is dependent upon environment, duty cycle, operating parameters and system cleanliness. Since these parameters vary from application to application, the ultimate user must determine and establish the periodic maintenance required to maximize life and detect potential component failure.

## G. Troubleshooting

Table 4 lists the common difficulties experienced with directional valves and systems. It also indicates the probable causes and remedies for each of the troubles listed.

Also remember that many apparent failures may actually be the failure of other parts of the system. The cause of improper operation is best diagnosed with adequate testing equipment and a thorough understanding of the complete hydraulic system.

TROUBLE	PROBABLE CAUSE	REMEDY
Valve spool fails to move	Dirt in system	Disassemble, clean and flush.
	Solenoids inoperative	Check electrical source and solenoids.
	Improper assembly	Check proper assembly. Refer to appropriate figure and assembly procedure.
	Improper installation connections	Check installation drawings
Valve produces undesirable response	Improper valve assembly	Check parts drawing and installation drawing for proper assembly and installation connections
	Improper installation connections	
	Solenoid wiring reversed	Reverse connections to the solenoids

Table 4. Troubleshooting Chart

## Section VIII - Overhaul

### WARNING



Before breaking a circuit connection, ensure system power is off and system pressure has been relieved. Lower all vertical cylinders, discharge accumulators and block any load whose movement could generate pressure. Plug all units and cap all lines to prevent entry of dirt into the unit or system.

#### A. Unit Removal

1. Thoroughly clean the exterior of the valve and the area around the valve to prevent contamination of the system during removal.
2. Remove the valve from its subplate or mounting pad as follows:
  - A. If the valve is equipped with the insta-plug feature, loosen the two slotted screws and unplug the electrical wiring from the pilot section.
  - B. If the valve has an air operated section, turn off air supply and disconnect the pressure lines from the connection plate.

### WARNING



In the following step make sure electrical power is off, then disconnect the solenoid wiring. Label each wire to provide assembly information.

- C. If the valve has standard electrically operated solenoids, remove the four nameplate screws on top of the pilot section. Move nameplate and gasket aside to expose interior of the wire cavity. Disconnect solenoid wiring.
- D. Loosen the six mounting screws that hold the main stage section to the mounting pad. Be ready to catch the fluid retained inside the lines and valve.
- E. Remove the valve from the mounting pad and set it on a clean work bench. Use a chain lift when necessary.

#### B. Disassembly (General)

The manual describes the disassembly sequence of a typical DG5V8 two-stage directional valve. See Figures 17 and 18. Slight variations may be noted on your model depending on the type of accessories and unit design. Figure 17 may be used for all models, except pressure centered "D" models regardless of the design. Refer to Section E and Figure 18 for pressure centered "D" models. Figure 19 shows the disassembly sequence of a DG4V-3(S)-\*A(L)/B(L)-FJ/FW-60 standard performance pilot valve.

#### C. Pilot Valve Crossover Plate Removal

1. Remove the four attaching screws (1) from the pilot valve or crossover plate (2). Remove the pilot valve from the main stage body (3).

### Note

The following section pertains to main stage disassembly. If your unit does not require main stage disassembly, omit the following section.

#### D. General Main Stage Disassembly (Refer to Figure 17)

### WARNING



Spring in end cover is under tension. Slowly remove end cover screws alternatively to avoid damage to equipment and injury to personnel

### Note

Repeat steps 1 and 2 for opposite side cover disassembly.

1. Loosen the four end cover screws (5) from end cover (6). Be ready to catch any oil trapped inside the unit. Remove the end cover and discard "O" ring (7).

### Note

Spring (8) and washer (9) do not exist on spring offset "A" or floating type models.

2. Remove spring (8) and washer (9) from the main stage spool (10).
3. Remove main stage spool (10) from body (3).
4. Turn the body (3) on its side and remove "O" rings (11 and 12) and plugs (14) and (15) from mounting face.
5. Remove plugs (16) and (17) and "O" Rings (18) and (19) from body (3).
6. If necessary, remove rest pins (13) with vise grip pliers.

**E. Pressure Centered Main Stage Disassembly**  
(Refer to Figure 18)

1. Remove the four attaching screws (1) from the crossover plate (2) and remove the crossover plate from the main stage body (3).

**Note**

The following section pertains to main stage disassembly. If your unit does not require main stage disassembly, omit the following section.

2. Loosen the four end cover screws (6) from end cover (7). Be ready to catch any oil trapped inside the unit. Remove the end cover, spring (10) and discard "O" ring (8).
3. Remove sleeve (11) and piston (12) from the main stage spool (9).
4. Remove main stage spool (9) from body (3).

**Note**

Perform step 5 for opposite side cover disassembly. Note that centering springs are different.

5. Loosen the four end cover screws (13) from end cover (14). Be ready to catch any oil trapped inside the unit. Remove the end cover, spring (15), centering washer (16) and "O" Ring (17).
6. Remove plug (18) and "O" Ring (19) from cover (7).
7. Turn the body (3) on its side and remove "O" rings (20, 24, 25 and 26) from mounting face.
8. If necessary, remove rest pins (27) with vise grip pliers.

**Note**

The following step pertains to integral check valve models only. DO NOT remove check valve parts unless inspection or unit operation indicates a check valve problem. If check valve removal is necessary, perform step 9.

9. See Table 7 for screw information. Obtain a piece of pipe or tubing with an inside diameter that is slightly larger than the outside diameter of the seat. Also obtain a flat washer. Remove seat (21), Figure 15, per instructions noted in Figure 15. Remove poppet (22) and spring (23).

Model	Screw Dia./ Thread Type	Screw Length
DG4V-3(S)	.5625-18 UNF-2B	76.2mm (3 in.)

Table 7. Screw Tabulation for Seat Removal

**Note**

DO NOT remove the internal plugs of body unless inspection reveals a problem.

10. Remove "O" rings (4) and (29), set screw (5) and plug (28) from body (3).

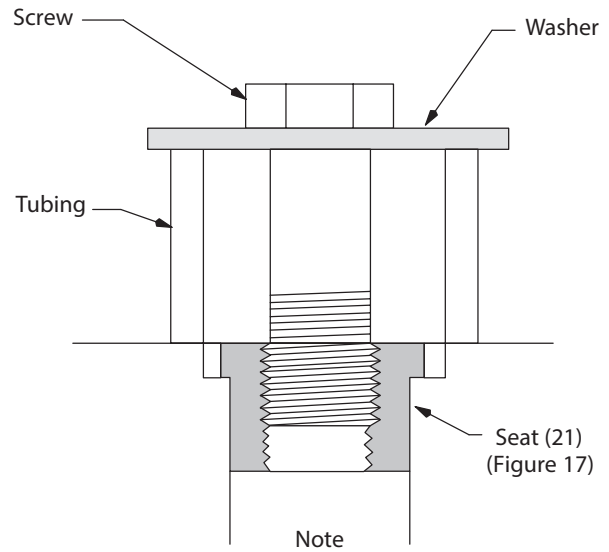

**Note**  
Thread seat (21), then place tubing and washer over seat area as shown. Thread the screw into seat (21). Tighten the screw to remove seat.

Figure 15. Check Valve Seat Removal

**F. High/Standard Performance Pilot Valve Disassembly**  
(Refer to Figure 19)

**Note**

The following steps describe the disassembly sequence of a DG4V-3(S)-\*A(L)/B(L)-FJ/FW-60 pilot valve.

1. Remove the four screws (1) from name plate (2) and remove the nameplate, cover (3) and gasket (4) from the terminal box (5). Discard gasket (4).
2. Remove two screws (7) and strap (8) from the terminal box (5).
3. Remove two screws (9), ground screw (11), terminal box (5) and gasket (6) from body (10). Discard gasket (6).

**Note**

If the pilot valve is equipped with two solenoids, perform steps 3 through 6 for opposite end of body (10).

4. Remove knob (12) from core tube S/A (21). Remove coil (14) from body (10) and discard "O" Rings (13) and (15). Unscrew core tube.
5. Remove push pin (18), spring 917, washer (19) or (20) and "O" Ring (15) from body (10). Remove "O" Ring (16) from core tube S/A (21).

6. Remove pilot spool (22) from body (10).
7. Secure the body and remove plug (24) and "O" Ring (25) from body (10). Discard "O" Ring (25).
8. If necessary, remove rest pins (26) with vise grip pliers.

#### H. Cleaning

All parts must be thoroughly cleaned and kept clean during inspection and assembly. Close tolerance of valve bodies and spools make this requirement critical. Clean all parts with a commercial solvent that is compatible with system fluid. Compressed air may be used to clean valve, but it must be filtered to remove water and contamination. Clean compressed air is particularly useful for cleaning spool orifices, body passages and drying parts.

#### I. Inspection, Repair and Replacement

1. Check that all internal passages are clean and free from obstruction. Examine all mating surfaces for nicks and burrs. Minor nicks and burrs can be removed with crocus cloth or an India stone.

#### CAUTION



DO NOT stone the edges of spool sealing lands. Remove minor burrs with #500 grit paper. Use the paper very lightly on the outer diameter of each spool.

2. Inspect all screws for evidence of damaged threads. If threads are damaged, replace the screws.
3. Inspect all springs for distortion or wear. The ends of the springs shall be square and parallel to each other. Replace springs that are damaged or distorted.
4. Check push pins, pole faces, washers, and manual plungers for burrs, cracks or mushrooming. Replace all parts that show evidence of wear.
5. Visually inspect the internal coring (bore) of each body for large scratches or erosion across the spool land sealing areas. If such evidence is found, replace valve. If the body bore passes inspection, check bore to spool clearance as follows:
  - A. Lubricate spools and body bores with clean system fluid. make sure the parts are clean.
  - B. Insert the spool into its body bore. Rotate the spool 360 ° while moving it back and forth. Observe the following:

If the spool does not move freely, the spool is sticking inside the body bore. Remove the spool and recheck the spool and body bore for scratches and/or burrs. remove any minor scratches or burrs with India stone or crocus cloth. Repeat steps A and B.

#### Note

An alternate test is to turn the body on end and allow gravity to pull the spool from the body into your hand. if the spool does not move under the influence of gravity, the spool is sticking inside the body bore.

If the spool binding persists, replace the valve.

Check the feel of the spool. If side movement of the spool can be felt within the body bore, the body/spool clearances are excessive. A new spool and body have a select fit of approximately 0.0002-0.0003 inch. Body/spool clearances in excess of this value may still work satisfactorily in your system; however, limitations are dependant on how much leakage your valve system can tolerate. Normally, excessive body/spool clearances dictate replacing the entire valve.

#### Note

If a new spool is installed into a new or used body, break the feathered edges of the spool balancing grooves with a three or four cornered India stone. See Figure 20. Lightly polish the spool with #500 grit paper. Wash the spool in clean solvent. Repeat steps A and B.

Step 6 pertains to detented "N" pilot valves only.

6. Check the detent by moving the spool through the detent. A steady frictional force should be observed. If the detent force is weak (less than 1 lb.), replace the detent subassembly. The detent should be assembled on both ends of the spool.
7. Perform a continuity test on each solenoid coil S/A. Resistance values will vary with the voltage rating of the coil. Refer to Table 8. This test is superficial, but a more rigorous test requires special equipment. If the coil seems to be burned or extreme heat is encountered during operation, the coil may be shorted. make sure the correct voltage is being applied to the coil.

Land Balancing Grooves

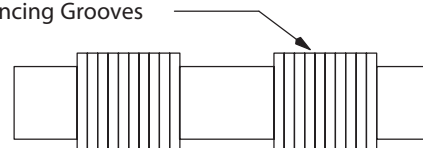

Figure 16. Spool Balancing Grooves

Voltage	Coil Resistance
6 DC	1.3 Ohms
12 DC	4.9 Ohms
24 DC	19.6 Ohms
48 DC	78.4 Ohms
115 DC	412 Ohms
230 DC	1680 Ohms
115 AC (60 Hz)	37 (3S) 30.5 (3) Ohms
230 AC (60 Hz)	154 (3S) 129 (3) Ohms
460 AC (60 Hz)	637 (3S) Ohms

Table 8. Coil Resistance

## J. Assembly

Before assembly, obtain the correct seal kit as noted in the parts drawing. Lubricate all "O" rings and internal parts with clean system fluid to provide initial lubrication and facilitate assembly.

Check the model code to determine correct assembly of units. If a L.H. suffix appears in the model code, the pilot valve solenoid is assembled left hand. Refer to service drawing for parts orientation.

Assembly will be in reverse of the disassembly sequence shown in Figures 17 and 18 unless otherwise specified.

## K. General Main Stage Assembly (Refer to Figure 17)

1. Install "O" rings (18 and 19) on plugs (16 and 17). Lubricate plug threads and install plugs into body (3). Torque plugs to value noted in parts drawing. Refer to Table 1.
2. Tap new rest pin(s) (13) into place if removed during disassembly.
3. Install "O" ring (11) into 'X' and 'Y' port mounting grooves.
4. Install "O" rings (12) into port mounting grooves 'A', 'B', 'P' and 'T'.
5. Lubricate spool lands with clean system fluid and then carefully install spool (10) into main body bore. Make sure the spool moves freely inside the body bore and is oriented properly. (See parts drawing).

### Note

Spring (8) and washer (9) do not exist on spring offset 'A' or 'floating' type models.

6. Install washer (9) and spring (8) on end of spool (10).
7. Install "O" ring (7) into body (3) as shown.

8. Install cover (6) on body (3) with four screws (5). Torque the screws to value noted in parts drawing. Refer to Table 1. Make sure cover is oriented properly (in line with body contours).

### Note

Repeat steps 6 through 8 for opposite side cover assembly.

## L. Pressure Centered Main Stage Assembly (Refer to Figure 18)

1. Install "O" rings on plugs. Lubricate plug threads and install plugs and set screws into body (3). Torque plugs to value noted in parts drawing. Refer to Table 1.
2. Tap new rest pin(s) (27) into place if removed during disassembly.

## L. Check Valve Models (Refer to Figure 18)

### Note

The following step pertains to integral check valve models only.

3. Place spring (23) into poppet (22) and then install poppet into pressure port (P) cavity as shown. Obtain a suitable push rod and press seat (21) into pressure port (P) cavity. (See assembly drawing for seat orientation.) Use an arbor press for this operation. Install "O" ring (20) into pressure port mounting groove.
4. Install "O" ring (26) into 'X' and 'Y' port mounting grooves.
5. Install "O" rings (25) into port mounting grooves 'A', 'B' and 'T'.
6. Install "O" ring (24) in port mounting groove 'W'.
7. Lubricate spool lands with clean system fluid and then carefully install spool (9) into main body bore. Make sure the spool moves freely inside the body bore and is oriented properly. (See parts drawing).
8. Install piston (12), sleeve (11) and spring (10) into cover (7).
9. Install "O" ring (8) in body (3).
10. Install cover (7) on body (3) with four screws (6). Torque the screws to the value noted in parts drawing. Refer to Table 1.
11. Install "O" ring (17), centering washer (16) and spring (15) in body (3).

---

12. Install cover (14) on body (3) with four screws (13).  
Torque the screws to the value noted in parts drawing.  
Refer to Table 1.

13. Install plugs (18) and "O" rings (19) into cover (7).

14. For DG3V8 models, install crossover plate (2) on body (3) with four screws (1). Torque screws to value noted in parts drawing. Refer to Table 1.

#### M. High/Standard Performance Pilot Valve Assembly (Refer to Figure 19)

1. Install "O" rings (25) on plugs (24). Lubricate plug threads and install into body (10). Install remaining "O" rings (25) into body (10). Torque plugs to the value shown in parts drawing. Refer to Table 1.

2. Lubricate pilot spool (22), then carefully install spool into the body (10).

#### Note

If pilot valve is equipped with two solenoids, repeat steps 3 through 7.

3. Assemble washer (19) or (20) on end of spool (22) with sharp break edge toward outside of body.

4. Install spring (18), push pin (17) and "O" ring (15) into body (10).

5. Install "O" ring (16) on core tube S/A (21) and install core tube S/A into body (10).

6. Install "O" ring (13) on core tube S/A (20).

7. Install coil (14) on body (10) and secure to core tube S/A (20) with knob (12).

8. Install gasket (6) and terminal box (5) on body (10) and secure with ground screw (11) and two screws (9).

9. Install strap (8) on terminal box (5) with two screws (7).

10. Install gasket (4), cover (3) and nameplate (2) on terminal box (5) with four screws (1).

# DG5V-8-S/H-\*(C)-10

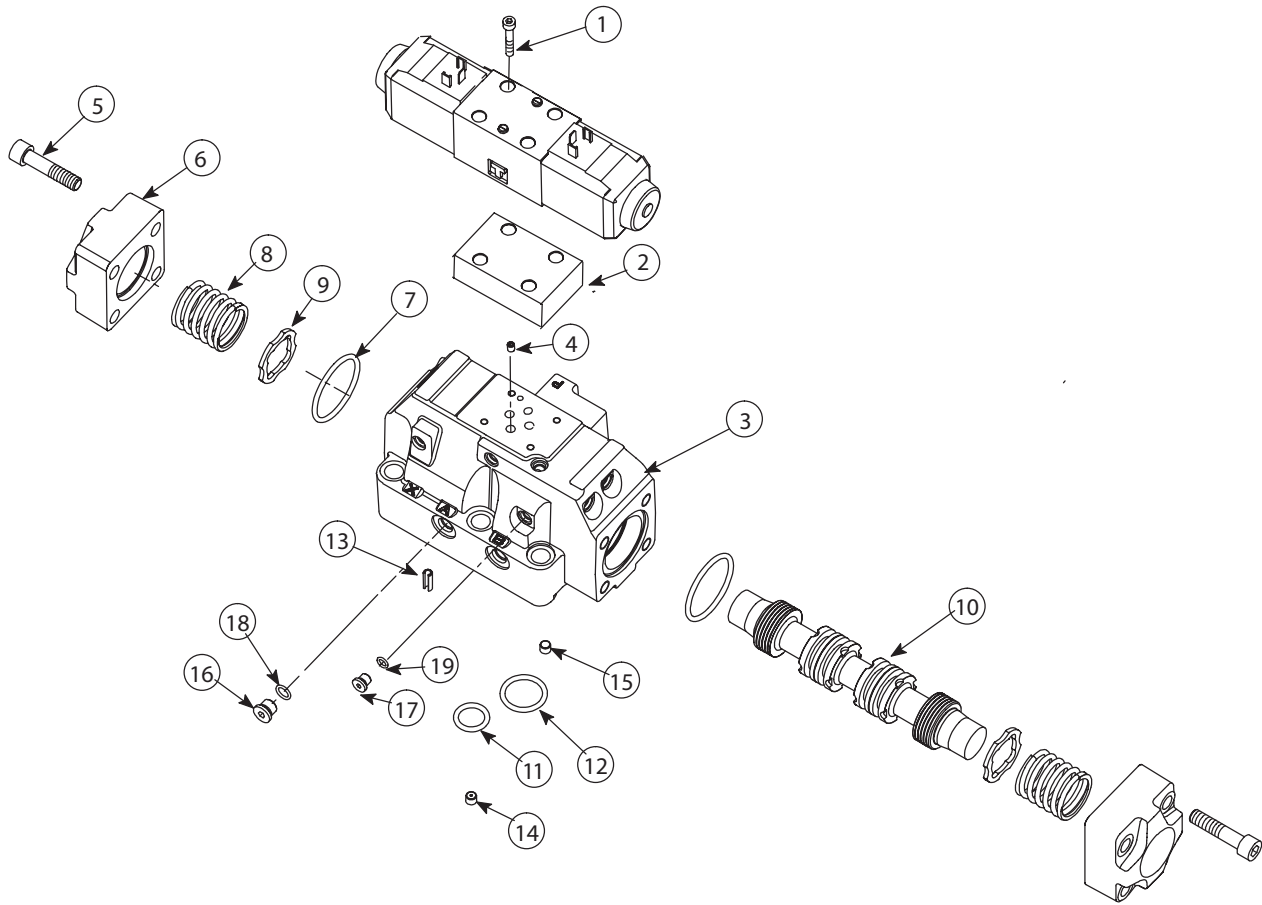

Item	Nomenclature	Quantity	Item	Nomenclature	Quantity
1	Screw	4	11	"O" Ring	2
2	Pilot Valve	1	12	"O" Ring	4
3	Body	1	13	Pin	2
4	Plug	1	14	Plug	1
5	Screw	8	15	Plug	1
6	Cover	2	16	Plug	2
7	"O" Ring	2	17	Plug	8
8	Spring	2	18	"O" Ring	2
9	Washer	2	19	"O" Ring	8
10	Spool	1			

Figure 17. Main Stage Section, Spring Centered "C" Model, DG5V-\*-S/H -\*(C)-10

# DG3V-8-\*(D)-10

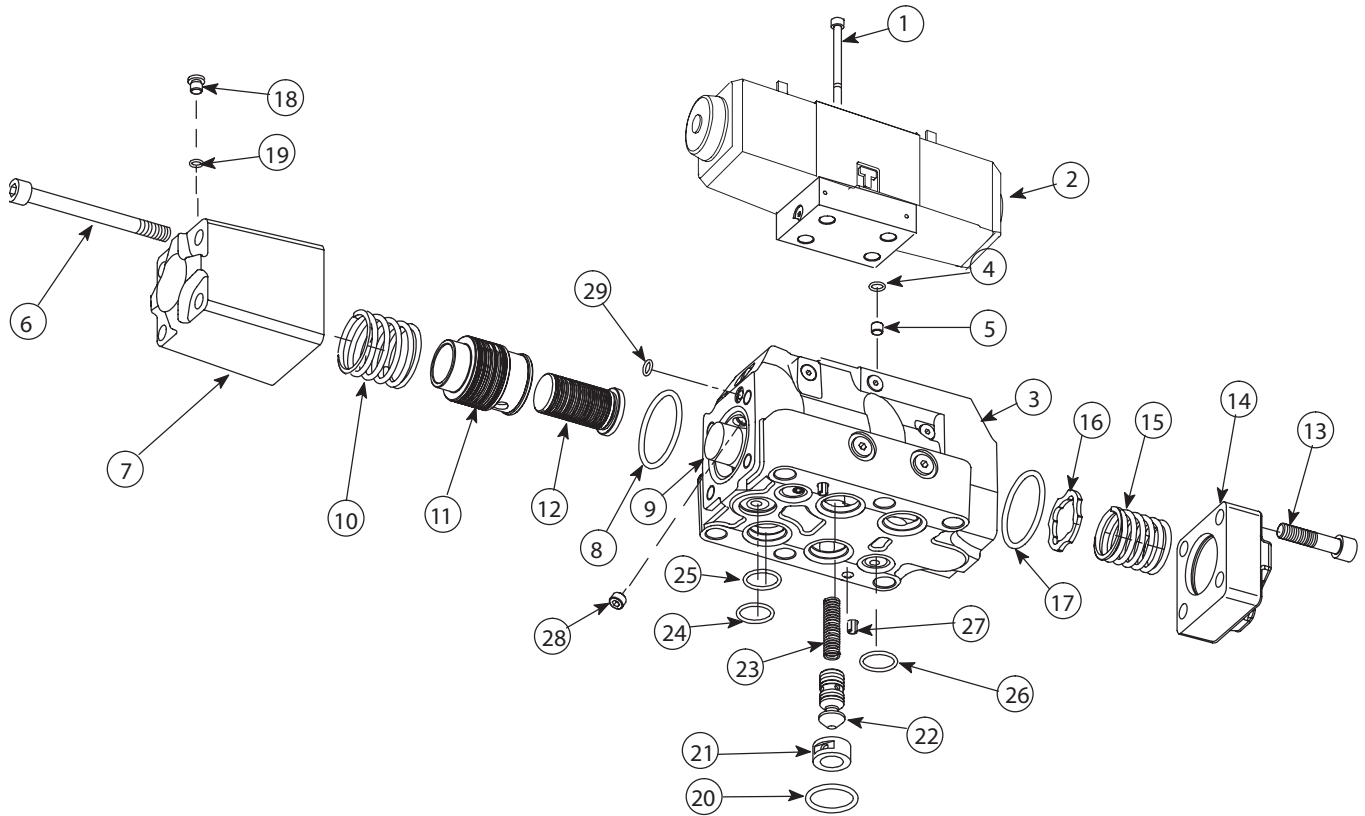

Item	Nomenclature	Quantity	Item	Nomenclature	Quantity
1	Screw	4	16	Centering Washer	1
2	Crossover Plate	1	17	"O" Ring	1
3	Body	1	18	Plug	4
4	"O" Ring	4	19	"O" Ring	1
5	Set screw	1	20	"O" Ring	1
6	Screw	4	21	Seat	1
7	Cover	1	22	Poppet	1
8	"O" Ring	2	23	Spring	1
9	Spool	2	24	"O" Ring	1
10	Spring	2	25	"O" Ring	3
11	Sleeve	1	26	"O" Ring	2
12	Piston	1	27	Rest Pin	2
13	Screw	4	28	Plug	1
14	Cover	1	29	"O" Ring	1
15	Spring	1			

Figure 18. DG3V-8-\*(D) (2/8/28)-10 Pressure Centered with Check Valve Options

# DG4V-3(S)-\*A(L)/B(L)-FJ/FW-60

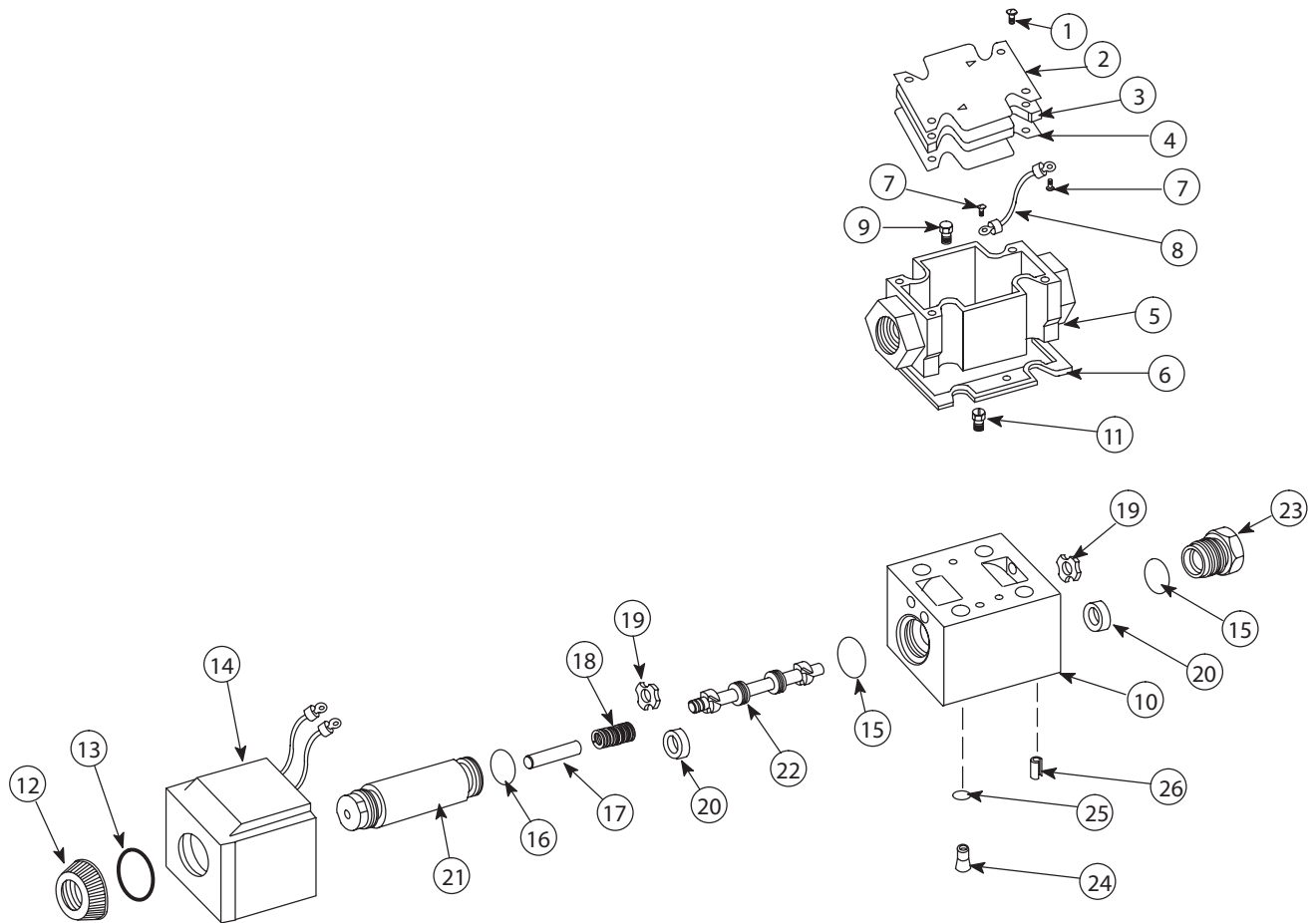

Item	Nomenclature	Qty	Item	Nomenclature	Qty
1	Screw	4	14	Coil	1
2	Nameplate	1	15	"O" Ring	2
3	Cover	1	16	"O" Ring	1
4	Gasket	1	17	Push Pin	1
5	Terminal Box	1	18	Spring	1
6	Gasket	1	19	Washer (DC models)	2
7	Screw	2	20	Washer (AC models)	2
8	Strap	1	21	Core Tube S/A	1
9	Screw	2	22	Spool	1
10	Body	1	23	Plug	1
11	Screw	1	24	Plug	1
12	Knob	1	25	"O" Ring	4
13	"O" Ring	1	26	Pin	1

Figure 19. Standard/High Performance Pilot Valve, DG4V-3(S)-\*A(L)/B(L)-FJ/FW-60

# Section IX - Internal Body Passages & Plug Locations

Two stage directional valves can be converted to different operational modes, i.e. internal/external, pilot pressure or drain, fast response, etc. To accomplish this, internal plugs must be removed or added within the main stage body passages.

Table 9 is a list of basic models with the incorporated operational model changes. Each model is referenced to a particular figure. The figure illustrates internal passages and plug locations.

Operational Mode Change  
(Reference Model Code, Table 2)

- \* - Standard
- X - Fast response option
- E - External pilot pressure
- K/Q/R/S - Integral check valve
- T - Internal pilot drain



**CAUTION**

DO NOT change internal plugs within mainstage unless power is off and system pressure is relieved.

Plug / Orifice Installation Table			
DG3V-8-(R)	"A" Plug/ Orifice	"B" Plug	"C" Plug
10	In	In	In
X-10	Out	In	
X-K/Q/R/S-10	In	In	
X-K/Q/R/S10	Out	In	

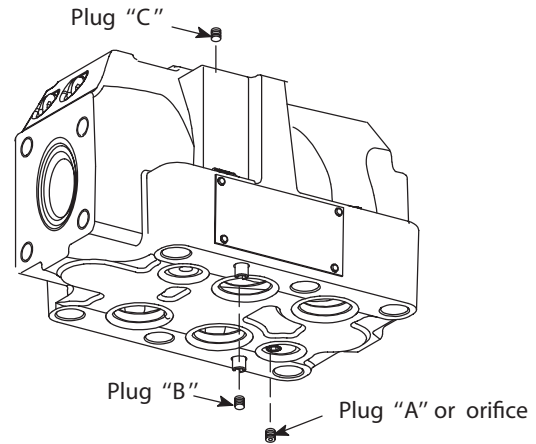

Figure 21

Basic Model Description	Ref.
DG3V-8-(R)-10 DG3V-8-(R)-E-10 DG3V-8-(R)-X-10 DG3V-8-(R)-E-K/Q/R/S-10 DG3V-8-(R)-X-E-K/Q/R/S-10 DG3V-8-(R)-X-K/Q/R/S-10 DG3V-8-(R)-X-E-K/Q/R/S-10 (OmitT) DG3V-8-(R)-X-E-T-K/Q/R/S-10	Fig. 21
DG5V-8-(R)-10 DG5V-8-(R)-E-10 DG5V-8-(R)-X-10 DG5V-8-(R)-E-K/Q/R/S-10 DG5V-8-(R)-X-E-K/Q/R/S-10 DG5V-8-(R)-X-K/Q/R/S-10 DG5V-8-(R)-X-E-K/Q/R/S-10 (Omit T) DG5V-8-(R)-X-E-T-K/Q/R/S-10	Fig. 21

Table 9. Basic Models

Plug / Orifice Installation Table			
DG5V-8-(R)	"A" Plug / Orifice	"B" Plug	"C" Plug
10	Out	In	In
E-10	In		
X-10	Out	Out	
E-K/Q/R/S-10	In	In	
X-E-K/Q/R/S-10	Out		
X-K/Q/R/S10		Out	
X-E-K/Q/R/S-10 (T omitted)		In	
X-E-T-K/Q/R/S-10		In	Out

# Section X - Start-Up and Test

---

## A. Start-Up

Start the system and sequence the unit through all positions while watching for appropriate movement of actuators. Improper or erratic movement of the actuators may indicate incorrect assembly of the unit or presence of trapped air.

## B. Test

A test stand having regulated flow, temperature control and special fixtures is required to fully test the performance of the rebuilt unit. Because of this, only the functional test shown in the start-up paragraph is given. If such a test stand is available, test the unit to the requirements set forth in the installation drawings.

### Products we offer:

- Cartridge valves
- DCV directional control valves
- Electric converters
- Electric machines
- Electric motors
- Gear motors
- Gear pumps
- Hydraulic integrated circuits (HICs)
- Hydrostatic motors
- Hydrostatic pumps
- Orbital motors
- PLUS+1® controllers
- PLUS+1® displays
- PLUS+1® joysticks and pedals
- PLUS+1® operator interfaces
- PLUS+1® sensors
- PLUS+1® software
- PLUS+1® software services, support and training
- Position controls and sensors
- PVG proportional valves
- Steering components and systems
- Telematics

**Danfoss Power Solutions** is a global manufacturer and supplier of high-quality hydraulic and electric components. We specialize in providing state-of-the-art technology and solutions that excel in the harsh operating conditions of the mobile off-highway market as well as the marine sector. Building on our extensive applications expertise, we work closely with you to ensure exceptional performance for a broad range of applications. We help you and other customers around the world speed up system development, reduce costs and bring vehicles and vessels to market faster.

Danfoss Power Solutions – your strongest partner in mobile hydraulics and mobile electrification.

### Go to [www.danfoss.com](http://www.danfoss.com) for further product information.

We offer you expert worldwide support for ensuring the best possible solutions for outstanding performance. And with an extensive network of Global Service Partners, we also provide you with comprehensive global service for all of our components.

Local address:

### Hydro-Gear

[www.hydro-gear.com](http://www.hydro-gear.com)

### Daikin-Sauer-Danfoss

[www.daikin-sauer-danfoss.com](http://www.daikin-sauer-danfoss.com)

**Danfoss  
Power Solutions (US) Company**  
2800 East 13th Street  
Ames, IA 50010, USA  
Phone: +1 515 239 6000

**Danfoss  
Power Solutions GmbH & Co. OHG**  
Krokamp 35  
D-24539 Neumünster, Germany  
Phone: +49 4321 871 0

**Danfoss  
Power Solutions ApS**  
Nordborgvej 81  
DK-6430 Nordborg, Denmark  
Phone: +45 7488 2222

**Danfoss  
Power Solutions Trading  
(Shanghai) Co., Ltd.**  
Building #22, No. 1000 Jin Hai Rd  
Jin Qiao, Pudong New District  
Shanghai, China 201206  
Phone: +86 21 2080 6201

Danfoss can accept no responsibility for possible errors in catalogues, brochures and other printed material. Danfoss reserves the right to alter its products without notice. This also applies to products already on order provided that such alterations can be made without subsequent changes being necessary in specifications already agreed. All trademarks in this material are property of the respective companies. Danfoss and the Danfoss logotype are trademarks of Danfoss A/S. All rights reserved.