

Data sheet

Thermostatic actuator QT

- return temperature control with AB-QM 4.0 valves

Description



QT is a self-acting thermostatic actuator designed to be used as return temperature control thermostat in one-pipe heating systems. QT is dedicated to be used with AB-QM 4.0 dynamic balancing & control valve.

AB-QM 4.0 together with QT is a complete one-pipe solution: AB-QT.

Main data:

- Setting range: 35-50 °C, 45-60 °C, 65-85 °C
- Designed for AB-QM 4.0 DN 15-32
- Easy-to-install external surface sensor

Benefits

- Reduces actual riser flow to match heat demand
- Improved room temperature control
- Reduced overheating of the building
- Reduced heating cost

Ordering

QT thermostatic actuator

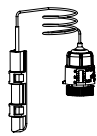

	Setting range (°C)	fit to AB-QM 4.0	Code No.
	35 ... 50	DN 15-32	003Z0397
	45 ... 60		003Z0398
	65 ... 85		003Z0399

Accessories

Type	Code No.
Pocket for submersible sensor	003Z0391
Sensor pocket kit	003Z0394
QT flow setting tag	003Z0395
Stroke limiter *	003Z1239

* Limits 5 % of nominal flow.

AB-QM 4.0 valves

	DN	Q _{max.} (L/h)	Ext. thread (ISO 228/1)	Int. thread (ISO 7/1)		DN	Q _{max.} (L/h)	Ext. thread (ISO 228/1)	Int. thread (ISO 7/1)
	15 LF	200	003Z8200	003Z8300		15 LF	200	003Z8220	003Z8320
	15	650	003Z8201	003Z8301		15	650	003Z8221	003Z8321
	20	1,100	003Z8203	003Z8303		20	1,100	003Z8223	003Z8323
	25	2,200	003Z8205	003Z8305		25	N/A	N/A	N/A
	32	3,600	003Z8207	003Z8307		32	N/A	N/A	N/A

For details on AB-QM and accessories please refer to AB-QM datasheet.

Applications

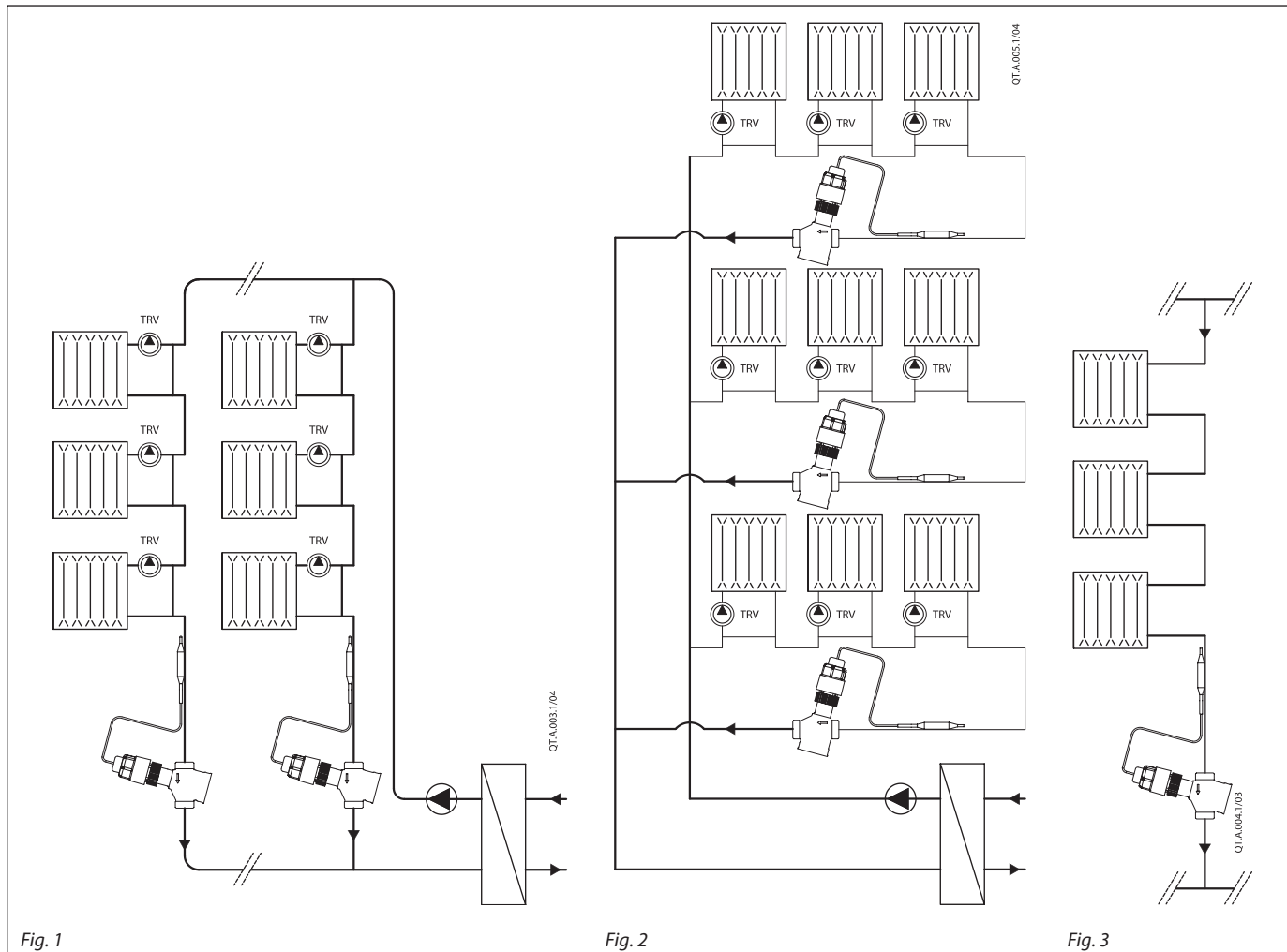

Fig. 1

Fig. 2

Fig. 3

QT is designed to be used in combination with AB-QM 4.0 in one-pipe heating systems. AB-QM 4.0 together with QT converts one-pipe heating system into energy efficient variable flow system, where flow in the risers is dynamically adjusted to match the load in the riser by control of return water temperature.

In one-pipe systems flow in the riser is always present. TRV on the radiator controls room temperature by controlling flow through radiator. However, by reducing flow through the radiator, water flow is not reduced but diverted to a by-pass and thus total water flow in the riser remains permanent. **Therefore at partial loads water temperature in the pipe is increasing.** As a result the riser itself with the by-pass pipe continues to heat the room. This can cause overheating of the room.

After the building is renovated the heating system becomes oversized since the heat losses of the building decrease. As a result overheating issue increases even more.

AB-QM 4.0 mounted in the riser provides a robust solution that offers reliable balance of one-pipe heating system at all system conditions. As a result, every riser gets design flow – and never more than that. Each riser becomes independent part of installation.

In addition, QT as a self-acting return temperature thermostat installed on AB-QM 4.0 provides flow control through the temperature of return water in the riser. By this water flow in the riser is dynamically controlled to match the actual load in the riser. This results in improved room temperature control and greatly reduced overheating of the building. Thus one-pipe systems become energy efficient variable flow systems, similar as Two-pipe systems are.

Typical applications are:

- one-pipe vertical riser based heating system (Fig. 1)
- one-pipe horizontal loop based heating system (Fig. 2)
- two-pipe vertical riser based heating system without TRV's, such as staircase or bathroom risers (Fig. 3)

Technical data

General data				
Setting range		35 ... 50	45 ... 60	65 ... 85
Temperature tolerance	°C	±3		
P-band ¹⁾		7		
Max adm temperature at sensor		90		
Capillary tube length	m	0.6		
Materials				
Housing	CuZn36Pb2As (CW 602N)			
Cone and diaphragm support	MPPE (Noryl)			
Main spindle	(CW 614N) Zn39Pb3			
Sensor cap	Polypropylene (Borealis HF 700-SA)			
Temperature sensor	Copper, mat. No. 2.0090			
Adapter	CuZn39Pb3 (CW 614N), coated with Cu Zn8B			
Nut	CuZn39Pb3 (CW 614N)			

¹⁾ at 50 % flow setting

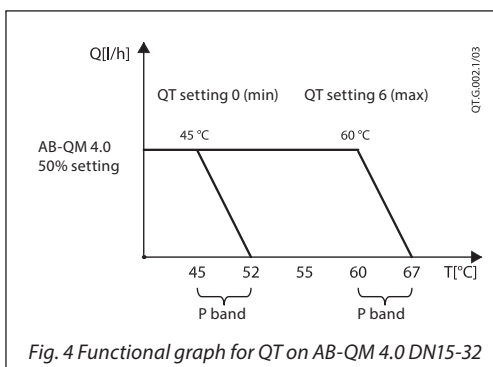

Fig. 4 Functional graph for QT on AB-QM 4.0 DN15-32

Mounting

When used in vertical based one-pipe heating system (Fig.1) AB-QM 4.0 is to be installed after the last radiator in the riser.

In horizontal based heating system (Fig.2) AB-QM 4.0 can be mounted also elsewhere in the loop, as long as the temperature sensor can be mounted after the last radiator in that loop.

QT should be mounted on the AB-QM 4.0 by hand. Maximum allowed torque is 5 Nm.

It is recommended to insulate the sensor if the thermostat is installed in a very cold place (< 5 °C).

Installation of the sensor

For proper heat transfer between a heating water pipe and the thermostad sensor, it is very important to apply thermo paste (included in the box) on the surfaces in contact.

Sensor itself can be mounted in any direction. For best performance of QT it is recommended to install sensor facing up (Fig. 7). It can be mounted either above or below sensor head.

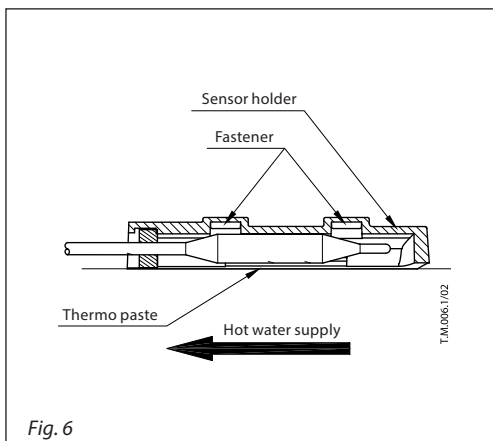

Fig. 6

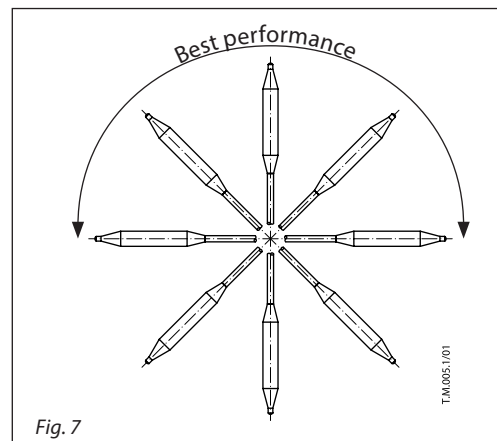

Fig. 7

Settings

QT temperature setting depends on AB-QM 4.0 flow setting.

It is necessary to set the AB-QM 4.0 according to required setting before the thermostat is mounted. It is recommended to set AB-QM 4.0 between 30 and 70 % flow setting.

QT thermostat is set to the desired setting by hand. When minimum or maximum setting is required, QT setting knob is to be moved slightly in opposite direction to ensure optimal performance of the thermostat.

AB-QM 4.0 DN 15-32 (45-60°C)

Temp. setting (°C)	QT Sensor setting (turns)							
	0	1	2	3	4	5	6	
AB-QM 4.0 (flow setting)	20 %	49.0	52.0	54.0	56.0	58.0	60.5	64.0
	30 %	48.0	50.0	52.5	54.5	56.0	59.5	63.0
	40 %	46.5	48.5	51.0	53.5	55.5	58.0	61.5
	50 %	45.0	47.0	49.5	52.0	54.5	57.0	60.0
	60 %	43.0	45.5	47.5	50.0	52.5	55.0	58.0
	70 %	41.0	43.0	45.5	48.0	50.5	53.0	56.5
	80 %	39.0	41.0	43.5	46.5	49.5	52.0	55.0
	90 %	38.0	39.5	42.0	44.5	47.0	50.0	53.0
	100 %	37.0	38.5	40.0	43.0	46.0	48.5	51.0

Factory setting of the thermostat is 4.

AB-QM 4.0 DN 15-32 (35-50°C)

Temp. setting (°C)	QT Sensor setting (turns)							
	0	1	2	3	4	5	6	
AB-QM 4.0 (flow setting)	20 %	40.0	43.0	46.5	49.0	52.0	54.5	57.0
	30 %	38.5	41.0	43.5	46.0	49.0	52.0	55.5
	40 %	37.5	39.5	41.0	43.5	46.5	49.5	52.5
	50 %	35.0	37.0	39.0	41.5	44.0	47.0	50.0
	60 %	34.0	36.0	38.0	40.5	42.5	45.5	48.5
	70 %	32.5	35.0	37.0	39.0	41.0	44.0	47.0
	80 %	31.5	33.5	36.0	37.5	39.5	42.5	45.5
	90 %	30.0	32.5	35.0	36.5	38.5	41.0	44.0
	100 %	29.0	31.5	34.0	35.5	37.5	40.0	43.0

Factory setting of the thermostat is 4.

AB-QM 4.0 DN 15-32 (65-85°C)

Temp. setting (°C)	QT Sensor setting (turns)							
	0	1	2	3	4	5	6	
AB-QM 4.0 (flow setting)	20 %	71.0	73.0	76.5	80.0	83.0	86.5	91.0
	30 %	69.0	71.5	75.5	78.0	81.0	84.5	88.5
	40 %	67.5	70.0	73.0	76.0	79.5	82.5	87.0
	50 %	65.0	68.0	71.5	74.5	78.0	81.0	85.0
	60 %	62.5	66.0	69.0	72.5	76.0	80.0	84.0
	70 %	60.5	64.0	66.5	70.0	74.5	78.5	83.0
	80 %	58.0	61.5	64.5	67.5	73.0	77.0	82.0
	90 %	54.0	58.0	62.0	66.0	70.5	75.5	81.0
	100 %	50.0	53.0	56.5	61.0	67.0	72.5	80.0

Factory setting of the thermostat is 4.

Commissioning

Flow on AB-QM 4.0 and temperature setting on QT need to be set to achieve best performance and efficiency of one-pipe heating system.

Recommended is a following 3 steps setting procedure:

1. AB-QM 4.0 setting
2. QT setting
3. follow up

There are 2 main reasons that influence one-pipe system efficiency and therefore AB-QM 4.0 and QT setting:

1. renovation status of the building since renovation is a major reason for a heating system to become oversized; generally, after building is renovated (wall & roof insulation, new windows) existing heating system becomes significantly oversized
2. a dynamic nature of the heating load that is changing unpredictably in the building due to partial loads, internal gains and weather conditions.

Note:

After renovation, one of possible steps to improve efficiency of the one-pipe heating system is also optimization (reduction) of supply water temperature. Together with AB-QT it offers additional efficiency improvements where influences mostly upper radiators in the riser/loop. In such case QT setting would practically not need to change.

1. AB-QM 4.0 setting

Required flow after building renovation is generally much lower than design flow that was calculated at the time building was designed. Flow is to be calculated based on actual heat losses—after renovation. Needed flow calculation is recommended to be based on original Δt . For best performance, recommended flow setting on AB-QM 4.0 is between 30 and 70 % flow setting.

2. QT setting – D_f Dynamic factor method

Temperature setting of the QT is influenced by dynamic factor D_f. Last radiator in the riser is normally the one which influences dynamic factor D_f at most. **D_f is to be selected from the table A.** Having dynamic factor selected, the correction value of return temperature can be chosen from Fig. B.

There are 2 factor that influence dynamic factor D_f:

1. ϕ_r , Renovation effectiveness [%]
2. Room type [A or B]

D_f can be selected for a building as a whole. However, various risers in the same building can have different characteristics (for example: kitchen compared to sleeping room, riser in the middle of the building compared to the one in the corner, etc). Therefore, for best efficiency also dynamic factor D_f on various riser within the same building can be different.

Commissioning (continuous)

1st factor, Renovation effectiveness ϕ_r , describes how much actual heat losses have been reduced after building renovation compared to original, design value. ϕ_r can be derived by:

$$\phi_r = 100 \times \left(1 - \frac{Q_r}{Q_n} \right) [\%]$$

$[Q_n]$ - design heat losses (nominal)
 $[Q_r]$ - actual heat losses (after renovation)

2nd factor depends on the what kind of room is heated by a particular riser. It is based on ISO 13790:

- Room type A: bedroom room, utility, other rooms with low average internal gains of cca 3 W/m²
 - Room type B: kitchen or living room, with high average internal gains of cca 9 W/m²
- Table A gives an overview of D_f values, based on value of both factors respectively.

Table A

Df - Dynamic factor	ϕ_r =renovation effectiveness [%]						
	0	10	20	30	40	50	60
Room type A (3 W/m ²)	8	19	31	43	54	66	78
Room type B (9 W/m ²)	17	29	41	52	64	76	88

Having dynamic factor selected for a particular building/riser, the correction value of return temperature can be chosen from Fig. B.

QT setting is calculated so that "return temperature correction" value is combined (summed up) with design return temperature (see examples).

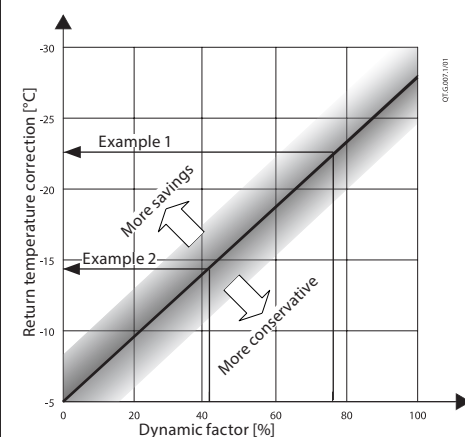

Fig. B - Return temperature correction

3. Follow up

Achieved energy efficiency of AB-QT solution depends on QT setting. For maximum results it is strongly recommended to perform follow up on the installation during first year of operation.

For further details please contact Danfoss representative or visit <http://www.danfoss.com/onepipesolutions>

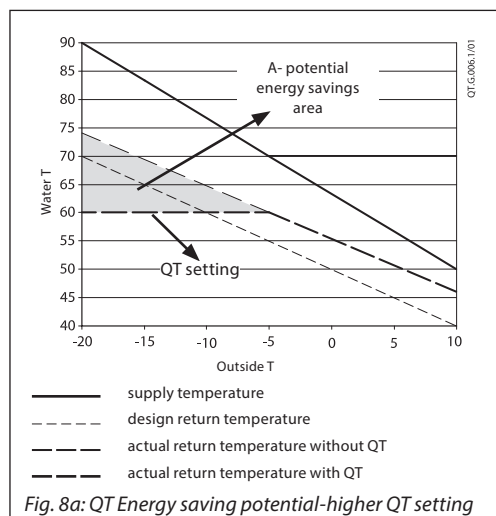

Fig. 8a: QT Energy saving potential-higher QT setting

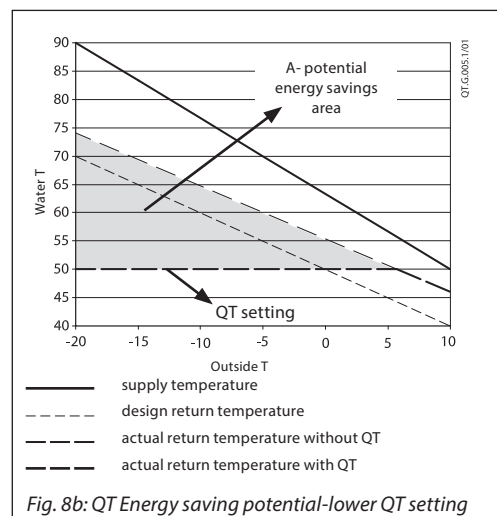

Fig. 8b: QT Energy saving potential-lower QT setting

Sizing – QT setting design examples

1. Example

Fig. 9 “Typical one-pipe riser with AB-QM 4.0 & QT installed”

A well renovated building.

Given:
 Design temperature system 90/70 °C
 Room type living room
 Design specific heat losses (before renovation) q_n 33 W/m²
 Specific heat losses (after renovation) q_r 17 W/m²

Required
 Temperature setting for QT

Solution:
 Based on:
 • Room type B (for living room)
 • And $\phi_r = 50\%$, where renovation effectiveness ϕ_r can be calculated as

$$\phi_r = 100 \times \left(1 - \frac{q_r}{q_n}\right) = 100 \times \left(1 - \frac{17}{33}\right) \approx 50\%$$

dynamic factor D_f 76 % can be identified from table A.

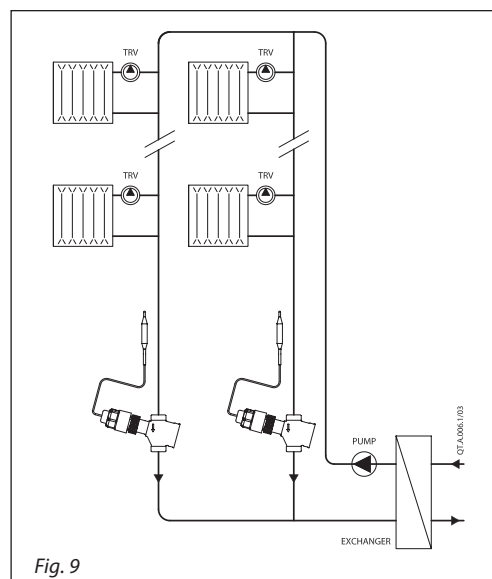

Based on $D_f = 76\%$, Fig. B gives return temperature correction of -23 °C .

Required QT setting is:
47 °C ($70\text{ °C} + (-23\text{ °C}) = 47\text{ °C}$)

2. Example

A partly renovated building (for example windows renovated only)

Given:
 Design temperature system 90/70 °C
 Room type bedroom
 Design specific heat losses q_n (before renovation) 49 W/m²
 Actual specific heat losses q_r (after renovation) 37 W/m²
 Actual riser heat losses Q_r 10.950 W

Required:
 1. AB-QM 4.0 size & setting
 2. QT temperature setting
 3. QT sensor setting (turns)

Solution
 1. AB-QM 4.0 setting is calculated based on actual heat losses after renovation and design ΔT .

$$q = \frac{Q_r}{\rho \times C_p \times \Delta t} = \frac{10950}{975 \times 4190 \times 20} \left[\text{m}^3/\text{s} \right]$$

$$q = 1.34 \times 10^{-5} \text{ m}^3/\text{s} = 482 \text{ l/h}$$

AB-QM 4.0 DN 20 is selected, where needed flow setting is 40 % for required 482 l/h.

2. QT temperature setting
 Riser type 2 in table A is a proper match:
 • Room type A (bedroom)
 • And $\phi_r = 25\%$, where renovation effectiveness ϕ_r can be calculated as

$$\phi_r = 100 \times \left(1 - \frac{Q_n}{Q_r}\right) = 100 \times \left(1 - \frac{37}{49}\right) = 25\%$$

Dynamic factor D_f 37% can be identified from table, based on ϕ_r value of 25% (between 20 and 30%)

Based on $D_f = 37\%$, Fig B gives return temperature correction of -13 °C .

Required QT setting is:
57 °C ($70\text{ °C} + (-13\text{ °C}) = 57\text{ °C}$)

3. QT sensor setting

Required
 QT temperature setting
 AB-QM 4.0 size DN 20
 AB-QM 4.0 setting 40 %

Solution
 On page 3, left setting table is selected. In a 40% AB-QM 4.0 setting row, required 57 °C QT temperature setting corresponds to 4.5 turns.

4.5 turns for QT sensor setting is selected.

AB-QM 4.0 DN 15-32 (45-60°C)

Temp. setting (°C)	QT Sensor setting (turns)						
	0	1	2	3	4	5	6
20 %	49.0	52.0	54.0	56.0	58.0	60.5	64.0
30 %	48.0	50.0	52.5	54.5	56.0	59.5	63.0
40 %	46.5	48.5	51.0	53.5	55.5	58.0	61.5
50 %	45.0	47.0	49.5	52.0	54.5	57.0	60.0
60 %	43.0	45.5	47.5	50.0	52.5	55.0	58.0
70 %	41.0	43.0	45.5	48.0	50.5	53.0	56.5
80 %	39.0	41.0	43.5	46.5	49.5	52.0	55.0
90 %	38.0	39.5	42.0	44.5	47.0	50.0	53.0
100 %	37.0	38.5	40.0	43.0	46.0	48.5	51.0

Design

1. Setting knob
2. Adapter
3. AB-QM 4.0 valve
4. Hot-water pipe
5. Temperature sensor

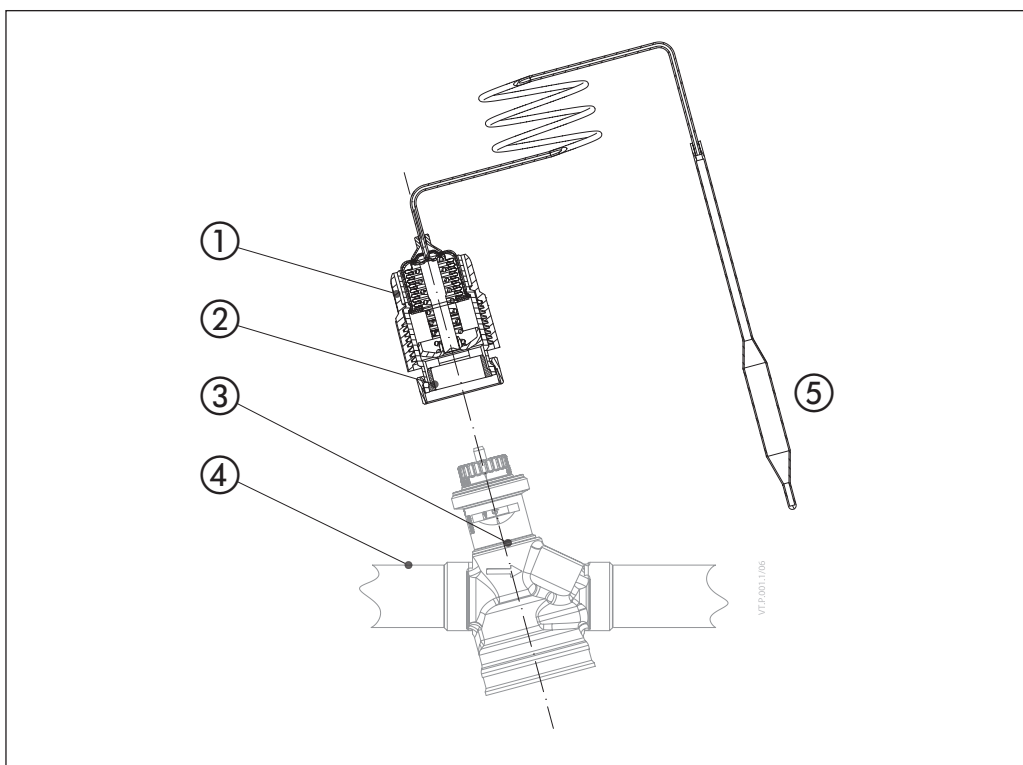

Dimensions

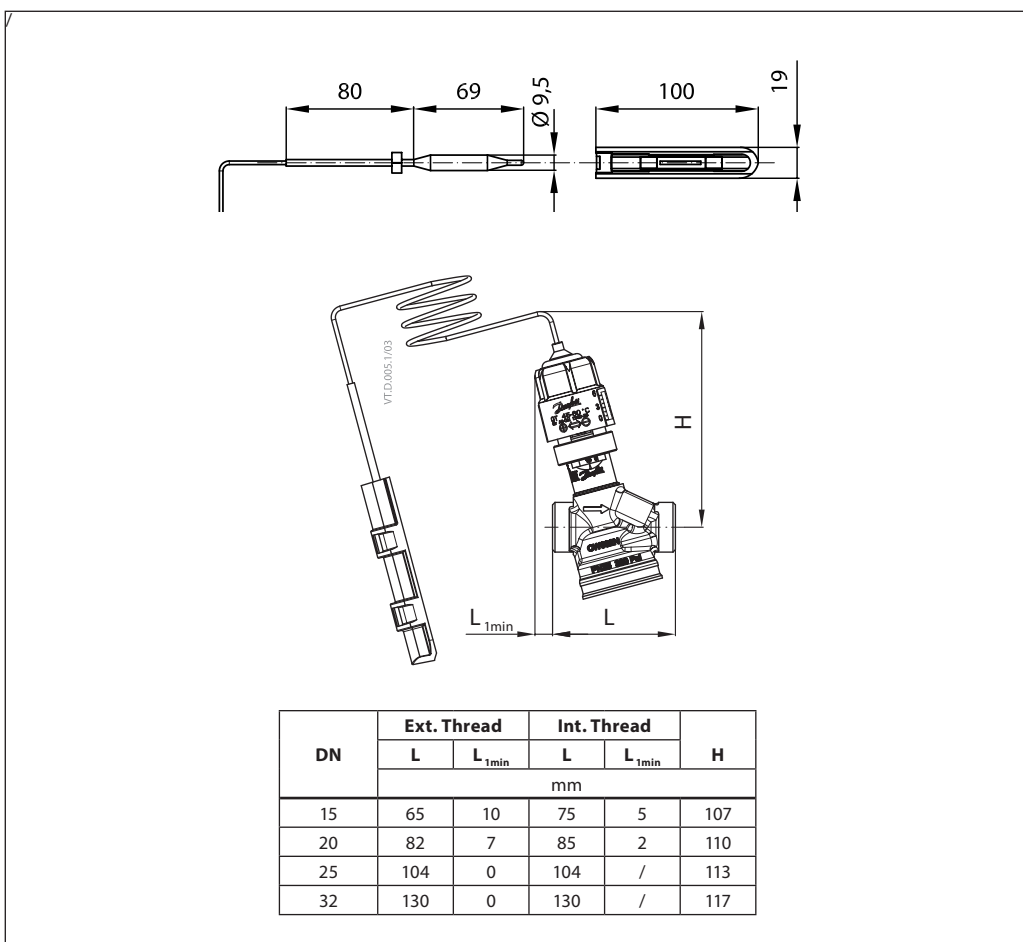



Danfoss A/S

Climate Solutions • danfoss.com • +45 7488 2222

Any information, including, but not limited to information on selection of product, its application or use, product design, weight, dimensions, capacity or any other technical data in product manuals, catalogues descriptions, advertisements, etc. and whether made available in writing, orally, electronically, online or via download, shall be considered informative, and is only binding if and to the extent, explicit reference is made in a quotation or order confirmation. Danfoss cannot accept any responsibility for possible errors in catalogues, brochures, videos and other material. Danfoss reserves the right to alter its products without notice. This also applies to products ordered but not delivered provided that such alterations can be made without changes to form, fit or function of the product.

All trademarks in this material are property of Danfoss A/S or Danfoss group companies. Danfoss and the Danfoss logo are trademarks of Danfoss A/S. All rights reserved.