

Technical Information

GearMe

Aluminum Group 2 and Group 3

Fan Drive Motor

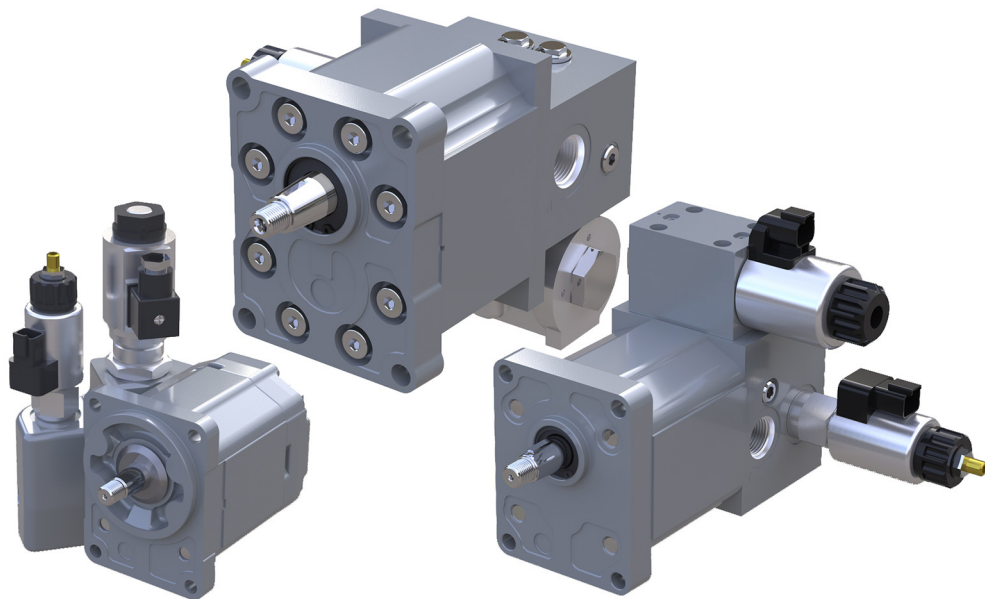

Revision history*Table of revisions*

Date	Changed	Rev
February 2023	Fixed typo	0104
January 2023	Renamed product	0103
December 2020	Unavailable options removed from page 20	0102
October 2019	First edition.	0101

Contents

General Information

Introduction.....5
 Typical Applications.....6
 Features and Benefits.....7
 Quick reference chart for fan drive motors.....7
 Determination of nominal motor size.....8
 Fan Drive Motors Circuit Illustrations.....9
 Fan Drive Motor Hydraulic Schematics..... 11

System Requirements

Pressure..... 12
 Speed..... 13
 Hydraulic Fluids..... 13
 Temperature and Viscosity..... 14
 Filtration..... 15
 Filters..... 15
 Selecting a filter..... 15
 Reservoir..... 15
 Line sizing..... 16
 Motor Shaft Connection..... 16
 Motor Life..... 16

Group 2

Model Code for Group 2 Fan Drive Motors..... 17
 Model Code for Integral Relief Valve Pressure Setting..... 20
 Model Code for Mounting Flange/Drive Gears (Group 2)..... 21

SGM2NC Fan Drive Motors (Group 2)

SGM2NC Technical Data..... 22
 SGM2NC Model Code Examples..... 22
 SGM2NC 02AA Dimensions..... 23
 SGM2NC 06BA Dimensions..... 25
 SGM2NC 06GB Dimensions..... 27

SGM2YN Fan Drive Motors (Group 2)

SGM2YN Technical Data..... 29
 SGM2YN Model Code Examples..... 29
 SGM2YN Electric Proportional Relief Valve Data..... 30
 SGM2YN 02AA Dimensions..... 31
 SGM2YN 06BA Dimensions..... 33
 SGM2YN 06GB Dimensions..... 35
 SGM2YN Outrigger Bearing Dimensions..... 37

SGM2VC Fan Drive Motors (Group 2)

SGM2VC Technical Data..... 38
 SGM2VC Model Code Examples..... 38
 SGM2VC Electric Proportional Relief and D03 Directional Valves Data..... 39
 SGM2VC 02AA Dimensions..... 40
 SGM2VC 06BA Dimensions..... 42
 SGM2VC 06GB Dimensions..... 44
 SGM2VC Outrigger Bearing Dimensions..... 46

Group 3

Model Code for Group 3 Fan Drive Motors..... 47
 Model Code for Integral Relief Valve Pressure Setting..... 50
 Model Code for Mounting Flange/Drive Gears (Group 3)..... 51

SGM3NC Fan Drive Motors (Group 3)

SGM3NC Technical Data..... 52
 SGM3NC Model Code Examples..... 52
 SGM3NC 07BC Dimensions..... 53
 SGM3NC 07GB Dimensions..... 55

Contents**SGM3YN Fan Drive Motors (Group 3)**

SGM3YN Technical Data.....	57
SGM3YN Model Code Examples.....	57
SGM3YN Electric Proportional Relief Valve Data.....	58
SGM3YN 07BC Dimensions.....	59
SGM3YN 07GB Dimensions.....	61
SGM3YN Outrigger Bearing Dimensions.....	63

SGM3VC Fan Drive Motors (Group 3)

SGM3VC Technical Data.....	64
SGM3VC Model Code Examples.....	64
SGM3VC Electric Proportional Relief and D03 Directional Valves Data.....	65
SGM3VC 07BC Dimensions.....	66
SGM3VC 07GB Dimensions.....	68
SGM3VC Outrigger Bearing Dimensions.....	70

General Information

Introduction

Danfoss has for many years built up a wealth of experience with its hydraulic and electro-hydraulic fan drive systems for vehicles and machines operating both on- and off-highway.

Modern fan drives require proportional electronic control to meet new emissions legislation. SGM2 and SGM3 fan drive motors are based on the proven high performance Danfossgear motors.

A proportional pressure relief valve with pilot operated spool (normally closed) is integrated in the cast-iron rear cover of the motor. A gear pump supplies oil to the fan drive motor. The PWM signal to the solenoid pressure relief valve controls the oil flow through the motor which determines the fan speed. The fan speed is controlled to maintain optimum engine and hydraulic system temperatures. The SGM2YN, SGM3YN, SGM2VC and SGM3VC provide this proportional control in an integrated package within the rear cover.

Bi-directional fan motor capability is necessary when it is desired to switch the rotation of the fan blade for such reasons as cleaning debris from a radiator. This allows for more efficient cooling of the machine engine and functions. The SGM2NC and SGM3NC provide the bidirectional capability for use with remote, inline mounted HIC manifolds that provide the reversing flow. The SGM2VC and the SGM3VC integrate the reversing valve capability in the rear cover of the motor.



General Information**Typical Applications**

Due to the versatility, flexibility and reliability of Danfoss fan drive systems, they may be applied in numerous applications, including the following.

Agriculture Machinery

- On-Off and fully modulating controls
- Increased engine reliability
- Automatic or On-demand reversing

Construction Machinery

- Backhoe loaders
- Crawler dozer - Crawler loader
- Wheel loaders
- Dump trucks - Haulers
- Excavators
- Skid steer loaders

Material Handling Vehicles

- Fork lift trucks
- Rough terrain trucks
- Telehandlers

Road Building Vehicles

- Pavers
- Graders
- Road rollers
- Crawlers

Forestry Machinery

- Feller bunchers
- Forwarders
- Harvesters
- Log skidders

On Highway Vehicles

- Buses
- RV motorhomes
- Garbage trucks
- Sweepers

High Power Specialty Vehicles

- Marine
- Oil and Gas drilling/Fracking
- Mining

General Information

Features and Benefits

- Two groups of frame size (Group 2 and 3)
- Steel and cast iron rear covers for 250 bar [3626 psi] continuous performance and 270 bar [3916 psi] peak pressure for all port configurations
- Displacement from 8 to 44 cm³/rev [from 0.51 to 2.69 in³/rev]
- Maximum speed 3500 min⁻¹ (rpm) for Group 2 and 2500 min⁻¹ (rpm) for Group 3
- Extreme temperature seals for continuous operation from -20°C [-4°F] up to 95°C [203°F], for today's more demanding applications.
- Two electro-hydraulic proportional valve options: PRV for standard fan speed modulation and optional flat curve valves for such applications as fan motors in series.
- DEUTSCH electrical connectors as standard to withstand dust and debris in the environment.
- 12 V_{DC} and 24 V_{DC} coils.
- Fail safe function - full fan speed if electrical signal fails.
- Pressure settings factory pre-set for individual system performance.
- High efficiency gear motors to reduce system losses and retain useful hydraulic power work functions
- Outrigger bearings available for all 3 models to provide increased bearing capacity and therefore more durability or extended life in applications such as slewing, tracked machines, vibe and shock load applications that possess gyroscopic and impact loads or heavy steel fan blades
- Shaft seal dust protector standard on all models for extended seal life in fan drive applications
- 2 Anti-Cavitation High Pressure Shock Valves, to clip pressure spikes in both directions of motor rotation, while reversing, where the competition uses only 1
- Integrated Reversing Directional Control Valves with open spool transitions to reduce system pressure spikes
- High performance valves and the use of steel / cast iron allows for full system pressure capability without de-rating the SGM product during reversing or proportional control
- Integrated valves packages and factory sealed outrigger bearings with high speed capability to preserve engine space
- PLUS+1[®] Compliant electronic interface allows for integration with PLUS+1[®] micro-controllers and other compliant products including sensors and graphical displays

Quick reference chart for fan drive motors

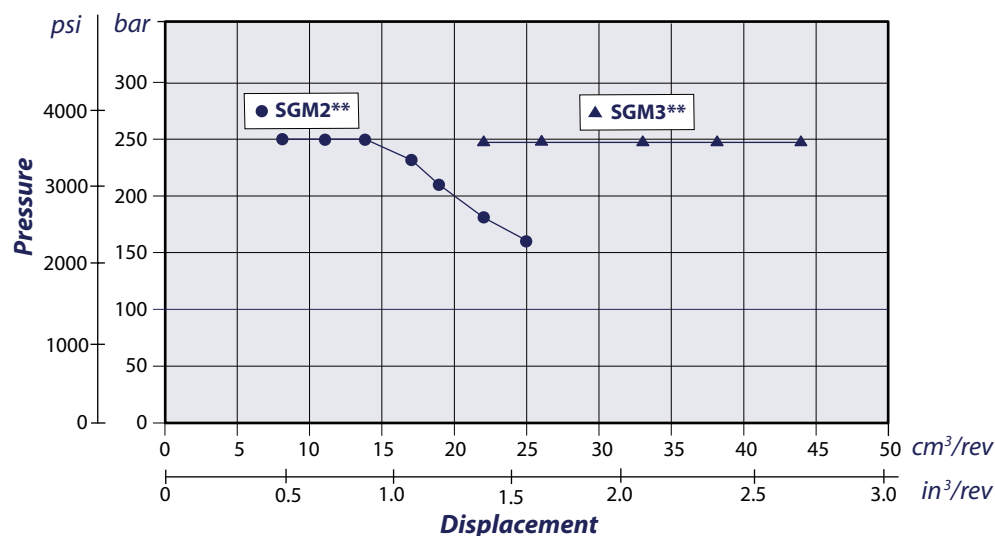

General Information
Determination of nominal motor size
Based on SI units

$$Q_e = \frac{V_g \cdot n}{1000 \cdot \eta_v}$$

$$M_e = \frac{V_g \cdot \Delta p \cdot \eta_{mh}}{20 \cdot \pi}$$

$$P_e = \frac{M_e \cdot n}{9550} = \frac{Q_e \cdot \Delta p \cdot \eta_t}{600}$$

$$n = \frac{Q_e \cdot 1000 \cdot \eta_v}{V_g}$$

Where:

Q_e	Input flow (l/min)
M_e	Output torque (N·m)
P_e	Output power (kW)
n	Speed (min ⁻¹)
V_g	Motor displacement per rev. (cm ³ /rev)
P_{high}	High pressure (bar)
P_{low}	Low pressure (bar)
Δp	High pressure minus Low pressure (bar)
η_v	Motor volumetric efficiency
η_{mh}	Mechanical-hydraulic efficiency
η_t	Motor total efficiency (η _v · η _{mh})

Based on US units

$$Q_e = \frac{V_g \cdot n}{231 \cdot \eta_v}$$

$$M_e = \frac{V_g \cdot \Delta p \cdot \eta_{mh}}{2 \cdot \pi}$$

$$P_e = \frac{V_g \cdot n \cdot \Delta p \cdot \eta_t}{396\,000}$$

$$n = \frac{Q_e \cdot 231 \cdot \eta_v}{V_g}$$

Where:

Q_e	Input flow [US gal/min]
M_e	Output torque [lb·in]
P_e	Output power [hp]
n	Speed [rpm]
V_g	Motor displacement per rev. [in ³ /rev]
P_{high}	High pressure [psi]
P_{low}	Low pressure [psi]
Δp	High pressure minus Low pressure [psi]
η_v	Motor volumetric efficiency
η_{mh}	Mechanical-hydraulic efficiency
η_t	Motor total efficiency (η _v · η _{mh})

General Information

Fan Drive Motors Circuit Illustrations

Gear pump/gear motor with HIC electrical control

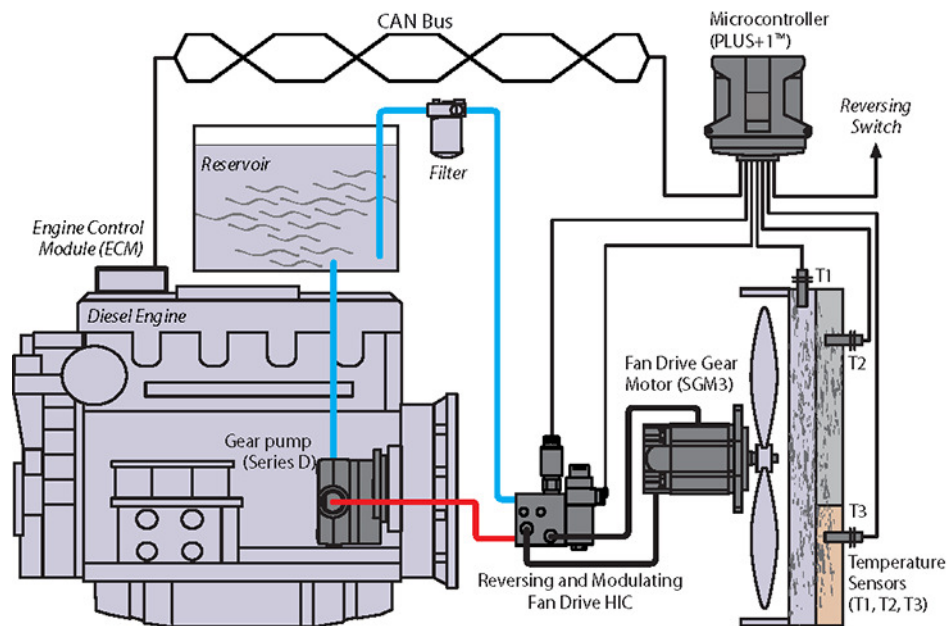

Gear pump/gear motor with electro-proportional relief valve

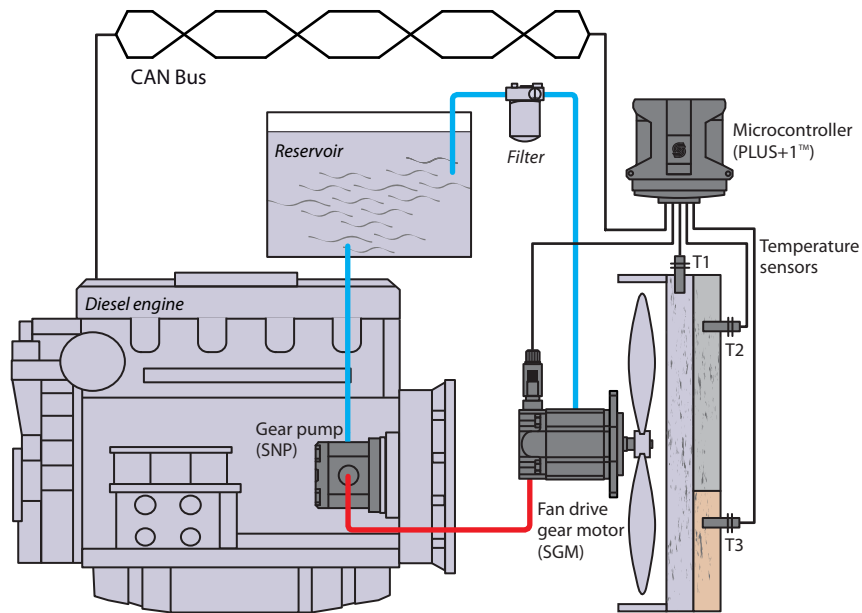

General Information

Gear pump/gear motor with integrated reversing control valve

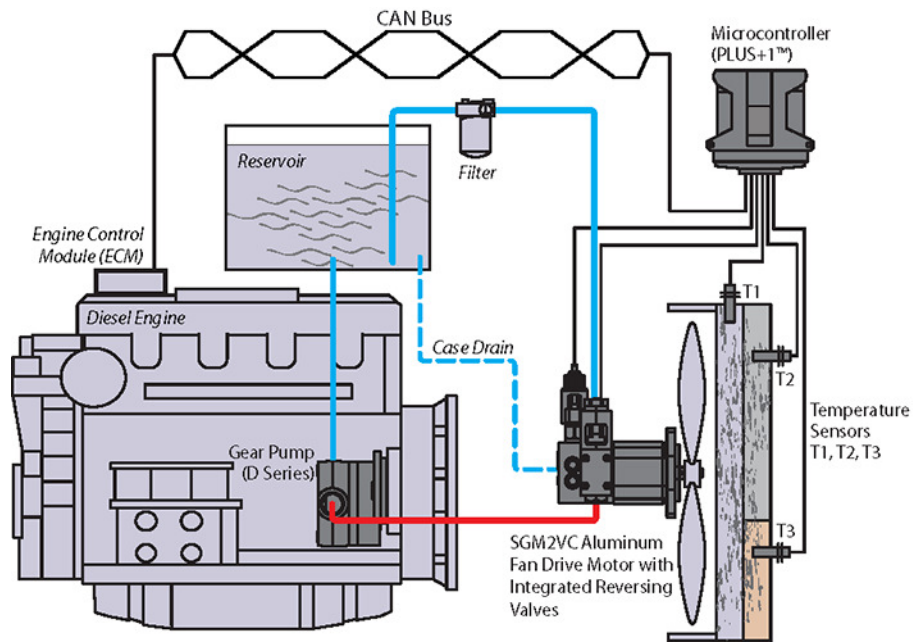

General Information

Fan Drive Motor Hydraulic Schematics

*SGM*NC Schematic*

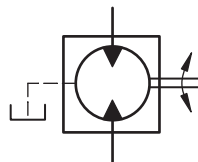

*SGM*Y Schematic*

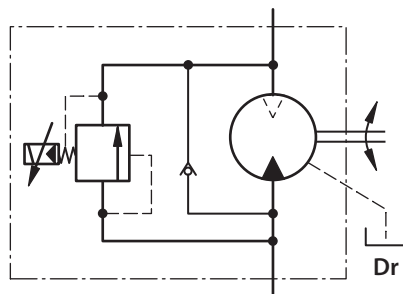

*SGM*VC Schematic*

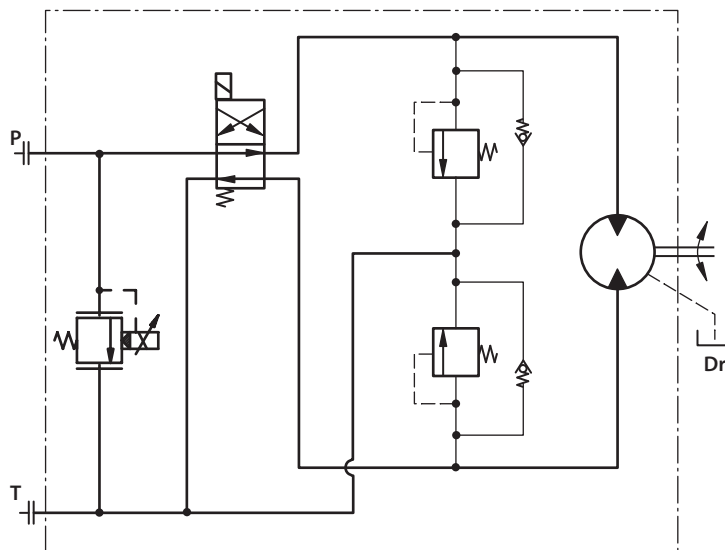

System Requirements

Pressure

Peak pressure is the highest intermittent pressure allowed at the pump's outlet. The relief valve overshoot (reaction time) determines peak pressure. It is assumed to occur for less than 100 ms.

Rated pressure is the average, regularly occurring operating inlet pressure that should yield satisfactory product life. The maximum machine load at the motor shaft determines rated pressure.

The illustration below shows peak pressure in relation to rated pressure and reaction time (100 ms maximum).

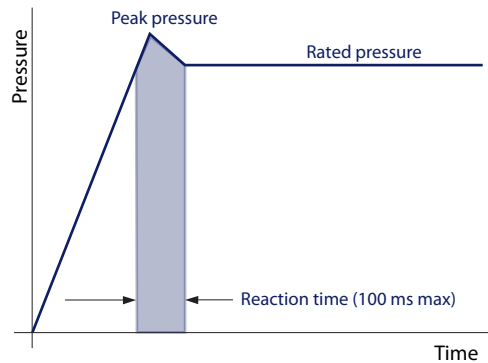

System pressure is the differential between the inlet and outlet ports. It is a dominant operating variable affecting hydraulic unit life. High system pressure, resulting from high load at the motor shaft, reduces expected life. System pressure must remain at, or below, rated pressure during normal operation to achieve expected life.

Back pressure is the average, regularly occurring operating outlet pressure that should yield satisfactory motor life. The hydraulic load demand downstream of the motor determines the back pressure. The fan drive gear motor can work with back pressure and the maximum back pressure allowed is 60% of the maximum rated pressure.

Case drain pressure is the regularly occurring case drain line pressure that should yield satisfactory motor life. It is recommended to design the case drain piping connecting the case drain direct to the tank in order to keep the case drain pressure as low as possible. Max. continuous case drain pressure allowed is 5 bar [72.5 psi] with a peak of 7 bar [101.5 psi].

System Requirements

Speed

Maximum speed is the limit recommended by Danfoss for a particular gear motor when operating at rated pressure. It is the highest speed at which normal life can be expected.

N_2 is max. speed related to the RV valve setting (p_2) and type of fan.

Minimum speed is the lowest operating speed limit at which normal life can be expected. The minimum speed increases according to operating pressure increase.

When operating at higher pressures, a higher minimum speed must be maintained, see below:

Speed versus pressure

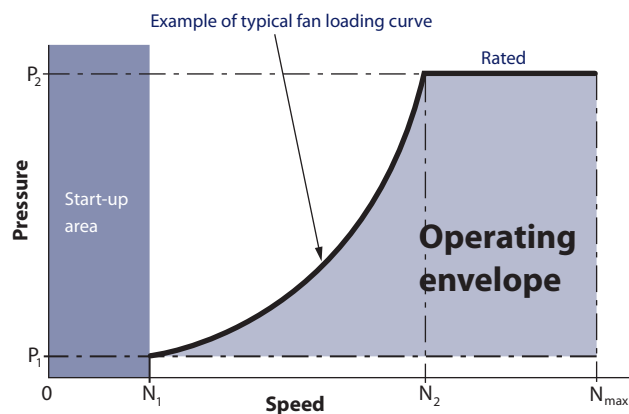

Hydraulic Fluids

Ratings and data for SGM2, SGM3 gear motors are guaranteed when the hydraulic system operates with premium hydraulic fluids without containing oxidation, rust, or foam inhibitors.

These fluids have to work with good thermal and hydrolytic stability to prevent wear, erosion, or corrosion of internal components. They include:

- Hydraulic fluids following DIN 51524, part 2 (HLP) and part 3 (HVLP) specifications
- API CD engine oils conforming to SAE J183
- M2C33F or G automatic transmission fluids
- Certain agricultural tractor fluids

! Caution

Use only clean fluid in the gear motors and hydraulic circuit. Never mix hydraulic fluids.

System Requirements

Temperature and Viscosity

Temperature and viscosity requirements must be concurrently met. Use of petroleum/mineral-based fluids is highly recommended.

High temperature limits apply at the inlet port of the motors. The motors should run at or below the maximum continuous temperature.

Minimum (cold start) temperature relates to the physical properties of component materials.

Maximum continuous temperature allowed at which normal life can be expected.

Peak (intermittent) temperature is the overheating temperature that is tolerable by the machine for a transient/limited time.

Cold oil, generally, doesn't affect the durability of motors components. It may affect the ability of oil to flow and transmit power. For this reason, keep the temperature at 16°C [60 °F] above the pour point of the hydraulic fluid.

Temperature limits

Minimum (cold start)	Maximum continuous	Peak (intermittent)
-20°C [-4°F]	95°C [203°F]	110°C [230°F]

Minimum viscosity occurs only during brief occasions of maximum ambient temperature and severe duty cycle operation. It's the minimum acceptable viscosity to allow normal motor life.

Maximum viscosity occurs only during cold start at very low ambient temperatures. It's the upper limit of viscosity that allows the motor to start.

- Size heat exchangers to keep the fluid within these limits
- Test regularly to verify that these temperatures and viscosity limits aren't exceeded
- Keep the fluid viscosity in the recommended viscosity range for maximum unit efficiency and bearing life

Fluid viscosity limits, in mm²/s [SUS]

Maximum (cold start)	Recommended range	Range for high efficiency	Minimum
1600 [7273]	12-100 [66-456]	20-50 [97-231]	10 [60]

System Requirements

Filtration

Filters

Use a filter that conforms to Class 22/18/13 of ISO 4406 (or better). It may be on the motor outlet (discharge filtration) or inlet (pressure filtration).

Selecting a filter

When selecting a filter, please consider:

- Contaminant ingress rate (determined by factors such as the number of actuators used in the system)
- Generation of contaminants in the system
- Required fluid cleanliness
- Desired maintenance interval
- Filtration requirements of other system components

Measure filter efficiency with a Beta ratio (β_x). β_x ratio is a measure of filter efficiency defined by ISO 4572. It is the ratio of the number of particles greater than a given diameter (in microns) upstream of the filter to the number of these particles downstream of the filter.

- For discharge filtration with controlled reservoir ingress rate, use a $\beta_{35-45} = 75$ filter
- For pressure filtration, use a filtration with an efficiency of $\beta_{10} = 75$

The filtration requirements for each system are unique. Evaluate filtration system capacity by monitoring and testing prototypes.

Fluid cleanliness level and β_x ratio

Fluid cleanliness level (per ISO 4406)	Class 22/18/13 or better
β_x ratio (discharge filtration)	$\beta_{35-45} = 75$ and $\beta_{10} = 2$
β_x ratio (pressure or return filtration)	$\beta_{10} = 75$
Recommended inlet screen size	100 – 125 μm [0.004 – 0.005 in]

Reservoir

The **reservoir** provides clean fluid, dissipates heat, removes entrained air, and allows fluid volume changes associated with fluid expansion and cylinder differential volumes. A correctly sized reservoir accommodates maximum volume changes during all system operating modes. It promotes de-aeration of the fluid as it passes through, and accommodates a fluid dwell-time between 60 and 180 seconds, allowing entrained air to escape.

Minimum reservoir capacity depends on the volume required to cool and hold the oil from all retracted cylinders, allowing for expansion due to temperature changes. A fluid volume of 1 to 3 times the pump output flow (per minute) is satisfactory. The minimum reservoir capacity is 125% of the fluid volume.

Install the suction line above the bottom of the reservoir to take advantage of gravity separation and prevent large foreign particles from entering the line. Cover the line with a 100-125 micron screen. The pump should be below the lowest expected fluid level.

Put the return-line below the lowest expected fluid level to allow discharge into the reservoir for maximum dwell and efficient deaeration. A baffle (or baffles) between the return and suction lines promotes deaeration and reduces fluid surges.

System Requirements

Line sizing

Choose pipe sizes that accommodate minimum fluid velocity to reduce system noise, pressure drops and overheating in order to maximize system life and performance. Line velocity should not exceed 5.0 m/s [16.4 ft/s].

Most systems use hydraulic oil containing 10% dissolved air by volume. Over-aeration, or entrained air, is the result of flow line restrictions, where the dissolved air comes out of solution, or when air is allowed to leak into the hydraulic circuit. These include inadequate pipe sizes, sharp bends, or elbow fittings, causing a reduction of flow-line cross-sectional area. This problem will not occur if these circuit recommendations are followed, rated speed requirements are maintained, and reservoir size and location are adequate.

Motor Shaft Connection

Allowable radial shaft loads are a function of the load position, load orientation, and operating pressure of the hydraulic motor. All external shaft loads have an effect on bearing life, and may affect motor performance.

Shaft options for fan drive gear motors include tapered (1:5 and 1:8) and parallel.

In applications where the external shaft loads cannot be avoided, minimize the impact on the motor by optimizing the orientation and the magnitude of the load. Danfoss fan drive gear motors are capable of carrying most manufacturer's plastic fans up to 7.27 kg (16 lb) fan blades for the Group 2 and 11.75 kg (26 lb) fan blades for the Group 3.

For fan drives exceeding these loads, with presence of shock loads, or for slewing (swing) and oscillating applications such as excavators, wheel loaders, harvesters, and windrowers, please consult your Danfoss technical representative for the potential usage of an outrigger bearing.

Motor Life

Motor life is a function of speed, system pressure, and other system parameters (such as fluid quality and cleanliness).

All Danfoss gear motors use hydrodynamic journal bearings that have an oil film maintained between the gear/shaft and bearing surfaces at all times. If the oil film is sufficiently sustained through proper system maintenance and operating within recommended limits, long life can be expected.

High pressure impacts motor life. When submitting an application for review, provide machine duty cycle data that includes percentages of time at various loads and speeds.

[B₁₀ life expectancy number is generally associated with rolling element bearings. It does not exist for hydrodynamic bearings.](#)

[Danfoss strongly recommends a prototype testing program to verify operating parameters and their impact on life expectancy before finalizing any system design.](#)

Group 2

Model Code for Group 2 Fan Drive Motors



A – Family

SGM2NC	Fan Drive Bi-directional Motor; External Axial Drain
SGM2GC	Fan Drive Uni-directional Motor; Anti-cavitation Check valve
SGM2YN	Fan Drive Motor with Proportional Pressure Valve, Axial Drain
SGM2YL	Fan Drive Motor with Proportional Pressure Valve, Radial Drain
SGM2VC	Reversible Fan Drive Motor with Proportional Pressure Valve

B – Frame size and displacement

8,0	8.4 cm ³
011	10.8 cm ³
014	14.4 cm ³
017	16.8 cm ³
019	19.2 cm ³
022	22.8 cm ³
025	25.2 cm ³

C – Direction of rotation

B	Bi-directional (SGM2NC) or Uni-directional (SGM2GC)
L	Left hand (Counter-clockwise)
R	Right hand (Clockwise)

D – Project version

A	High temperature sealing, dust protector, rust protected screws
----------	---

E – Mounting flange

01	European 01: Pilot Ø36.5 mm; 4 holes, special for fan drive (without dust protector)
02	European 02: Pilot Ø80 mm; 4 holes
06	SAE A pilot Ø82.55 mm; 2 holes
9Y	SAE A pilot Ø82.55 mm; 2 holes; outrigger bearing with dust cover

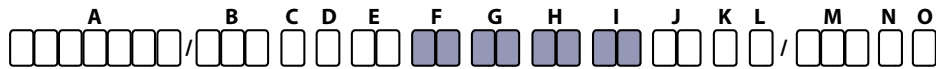
Group 2
Model Code for Group 2 Fan Drive Motors

F – Drive gear

AA	Taper 1:5; M12x1.25 with Key 3
BA	Taper 1:8; M12x1.25 with Key 4
FA	Parallel Ø15 x 36,5 mm; with Key 4x25
GB	Parallel SAE Ø15.875 x 50.8 mm; with Key 4x40

 For more details about configuration, see [Model Code for Mounting Flange/Drive Gears \(Group 2\)](#) on page 21.

G – Rear cover

C5	Cast Iron cover: 7/8–14 UNF–2B; In/Out Ports: 9/16–18 UNF–2B Axial Drain (idler gear side)
CX	Cast Iron cover: 7/8–14 UNF–2B; In/Out Ports: 9/16–18 UNF–2B Radial Drain (idler gear side)
CZ	Cast Iron cover: 7/8–14 UNF–2B; In/Out Ports: 9/16–18 UNF–2B Radial Drain (shaft side)
Y6	Cast Iron cover: 7/8–14 UNF–2B; In Port: 9/16–18 UNF–2B Axial Drain (idler gear side)
Y4	Cast Iron cover: 7/8–14 UNF–2B; In Port: 9/16–18 UNF–2B Radial Drain (idler gear side)
YX	Cast Iron cover: 7/8–14 UNF–2B; In Port: 9/16–18 UNF–2B Radial Drain (shaft side)
RA	Proportional PRV Reversing Valve Cover, 12 V _{DC} V03 DEUTSCH connector, Anti-Shock-MakeUp Valve, 7/8–14 UNF Work Ports, 9/16–18 UNF Radial Drain Port
RB	Proportional PRV Reversing Valve Cover, 24 V _{DC} V03 DEUTSCH connector, Anti-Shock-MakeUp Valve, 7/8–14 UNF Work Ports, 9/16–18 UNF Radial Drain Port

H – Inlet ports

NN	Without inlet on body
-----------	-----------------------

I – Outlet ports

Code	Dimensions	Ports	Code	Thread Dimensions
B5	15x35xM6		D7	M22x1.5
			D9	M26x1.5
B6	15x40xM6		E5	7/8-14UNF
			E6	1 ¹ / ₁₆ -12UN
			F4	1/2 Gas
B7	20x40xM6		F5	3/4 Gas
			H5	M18 x 1.5 per ISO6149
NN	Without outlet on body		H7	M22 x 1.5 per ISO6149
		H8	M27 x 2 per ISO6149	

Group 2
Model Code for Group 2 Fan Drive Motors

J – Ports positions and special body

NN	Standard from catalogue
-----------	-------------------------

K – Seals

N	Standard seals for high temperature (11172969)
W	Standard seals for high temperature without dust cover

L – Screws

N	Rust protected screws
----------	-----------------------

M – Valve setting

NNN XNN	No valve
***	Integral relief valve pressure setting*

* For more details see [Model Code for Integral Relief Valve Pressure Setting](#) on page 20.

N – Type marking

N	Standard Danfoss marking
A	Standard Danfoss marking + Customer code
Z	No marking
*	Special customer marking

O – Marking position

N	Standard marking on the top
A	Special marking position at the bottom

Group 2

Model Code for Integral Relief Valve Pressure Setting



M – Valve setting

XNN	No valve											
XA*	Standard relief valve with coil voltage 12 V_{DC} , DT connector											
XB*	Standard relief valve with coil voltage 24 V_{DC} , DT connector											
X**	<table border="1"> <tr> <td>X*F</td> <td rowspan="10"> Three color curves represent three types of valves. Each valve is characterized by different nominal spring ranges. Select requirements using the graph Pressure vs. Bypass flow below: </td> </tr> <tr> <td>X*I</td> </tr> <tr> <td>X*M</td> </tr> <tr> <td>X*O</td> </tr> <tr> <td>X*Q</td> </tr> <tr> <td>X*S</td> </tr> <tr> <td>X*U</td> </tr> <tr> <td>X*W</td> </tr> <tr> <td>X*Y</td> </tr> </table>	X*F	Three color curves represent three types of valves. Each valve is characterized by different nominal spring ranges. Select requirements using the graph Pressure vs. Bypass flow below:	X*I	X*M	X*O	X*Q	X*S	X*U	X*W	X*Y	<p>The graph plots Δ Pressure (psi and bar) against Bypass flow (l/min and US gal/min). It shows curves for valves F through Y. Curves F, I, M, and O are black and blue dashed lines. Curves Q, S, U, and W are red lines. Curve Y is a black line. All curves show an upward trend of pressure with increasing flow.</p>
X*F	Three color curves represent three types of valves. Each valve is characterized by different nominal spring ranges. Select requirements using the graph Pressure vs. Bypass flow below:											
X*I												
X*M												
X*O												
X*Q												
X*S												
X*U												
X*W												
X*Y												

Group 2

Model Code for Mounting Flange/Drive Gears (Group 2)

Danfoss offers two types of industry standard mounting flange:

- **02** European, Pilot Ø80 mm; 4 holes
- **06** SAE A pilot Ø82.55 mm; 2 holes

Spline configuration is not available for fan drive motors. Other shaft options may exist. Contact your Danfoss representative for availability. The table below shows order codes for each available mounting flange and shaft:

Model code sections: E and F

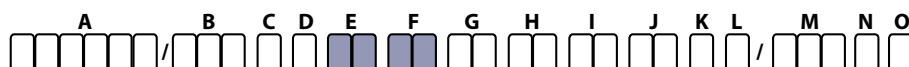

Mounting flange/Drive gear availability with max. torque

Mounting Flange			Drive Gear		
Code E	Description		Code F	Description	Maximum torque
01	European, Pilot Ø 36.5 mm; 4 holes Special for fan drive		BA	Taper 1:8; M12x1.25 with Key 4	 150 N•m [1328 lbf•in]
			FA	Parallel Ø15 mm; 36.5 mm long	 90 N•m [797 lbf•in]
02	European Pilot Ø80 mm; 4 holes		AA	Taper 1:5; M12x1.25 with Key 3	 140 N•m [1239 lbf•in]
06	SAE A pilot Ø82.55 mm; 2 holes		BA	Taper 1:8; M12x1.25 with Key 4	 150 N•m [1328 lbf•in]
			GB	Parallel Ø15.875 mm; 50.8 mm long	 80 N•m [708 lbf•in]
9Y	Outrigger Bearing with dust cover SAE A pilot Ø82.55 mm; 2 holes		DB	Taper 1:8; M12x1.25 with Key 4	 130 N•m [1151 lbf•in]

! Caution

Shaft torque capability may limit allowable pressure. Torque ratings assume no external radial loading. Applied torque must not exceed these limits, regardless of stated pressure parameters. Maximum torque ratings are based on shaft torsional fatigue strength.

SGM2NC Fan Drive Motors (Group 2)

SGM2NC is Group 2 bidirectional fan drive motor with inlet/outlet on cast iron rear cover and axial drain line, PLUS+1 compliant.

Group 2 fan drive motors are available in displacements from 8.4 cm³/rev [0.51 in³/rev] to 25 cm³/rev [1.54 in³/rev].

Configurations include European and SAE flanges; taper 1:8, 1:5, and straight shafts Ø15.875 mm [0.62 in].

Outtrigger bearing available as SAE A flange with taper shaft 1:8 and European flange with taper shaft 1:5.

SGM2NC Technical Data

	Units	Frame size						
		8.0	011	014	017	019	022	025
Displacement	cm ³ /rev [in ³ /rev]	8.4 [0.51]	10.8 [0.66]	14.4 [0.88]	16.8 [1.03]	19.2 [1.17]	22.8 [1.39]	25.2 [1.54]
Peak pressure	bar [psi]	270 [3916]	270 [3916]	270 [3916]	250 [3626]	230 [3336]	200 [2900]	180 [2610]
Rated pressure		250 [3626]	250 [3626]	250 [3626]	230 [3336]	210 [3046]	180 [2610]	160 [2320]
Back pressure		250 [3626]	250 [3626]	250 [3626]	230 [3336]	210 [3046]	180 [2610]	160 [2320]
Maximum speed	min ⁻¹ [rpm]	3500	3500	3500	3500	3200	3200	3200
Minimum speed		700	700	700	500	500	500	500
Weight	kg [lb]	3.2 [7.05]	3.75 [8.26]	3.9 [8.60]	4.05 [8.93]	4.15 [9.15]	4.3 [9.48]	4.4 [9.70]
Moment of inertia of rotating components	x 10 ⁻⁶ kg·m ² [x 10 ⁻⁶ lbf·ft ²]	32.4 [796]	38.4 [911]	47.3 [1122]	53.3 [1265]	59.2 [1405]	68.1 [1616]	74.1 [1758]

SGM2NC Model Code Examples

Model code examples with maximum shaft torque

Flange/shaft	Model code example	Maximum shaft torque
02AA	SGM2NC/011BA02AAC5NNNNNNNN/NNNNN	140 N·m [1239 lb·in]
06BA	SGM2NC/011BA06BAC5NNNNNNNN/NNNNN	150 N·m [1328 lb·in]
06GB	SGM2NC/011BA06GBC5NNNNNNNN/NNNNN	80 N·m [708 lb·in]

[For further details on ordering, see *Model Code for Group 2 Fan Drive Motors* on page 17.](#)

SGM2NC Fan Drive Motors (Group 2)

SGM2NC 02AA Dimensions

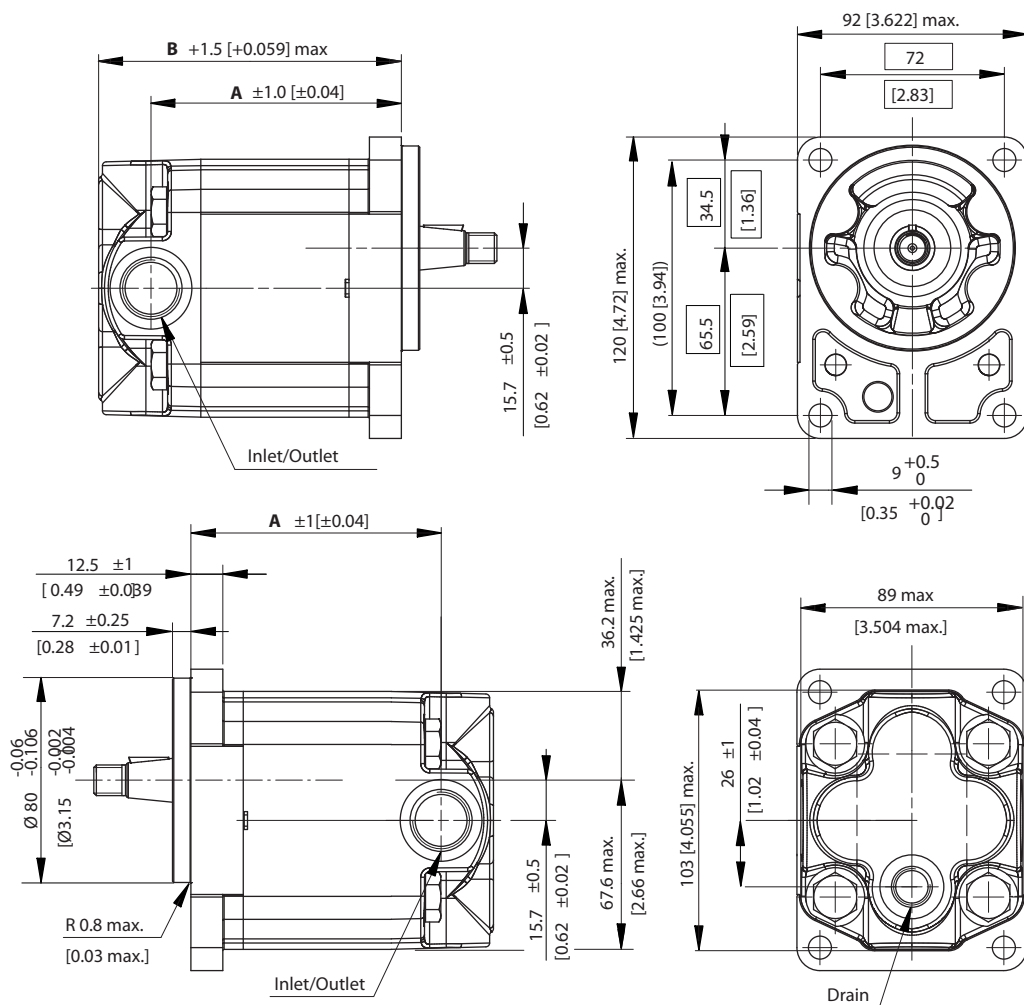

SGM2NC – 02AA dimensions

Dimension	Frame size						
	8,0	011	014	017	019	022	025
A	98 [3.86]	102 [4.01]	108 [4.25]	112 [4.41]	116 [4.57]	122 [4.80]	126 [4.96]
B	118.5 [4.66]	122.5 [4.83]	128.5 [5.05]	132.5 [5.22]	136.5 [5.37]	142.5 [5.61]	146.5 [5.77]
Inlet/Outlet	7/8–14UNF–2B (SAE J1926/1, O-Ring boss); 16.7 [0.66] min. full thread						
Drain port	9/16–18UNF–2B (SAE J1926/1 O-Ring boss); 12.7 [0.5] min. full thread						

SGM2NC Fan Drive Motors (Group 2)

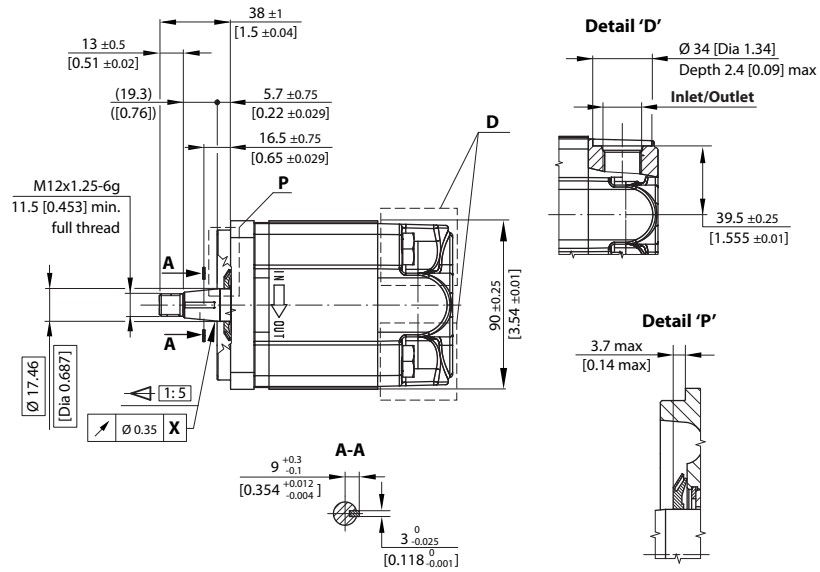

SGM2NC Fan Drive Motors (Group 2)

SGM2NC 06BA Dimensions

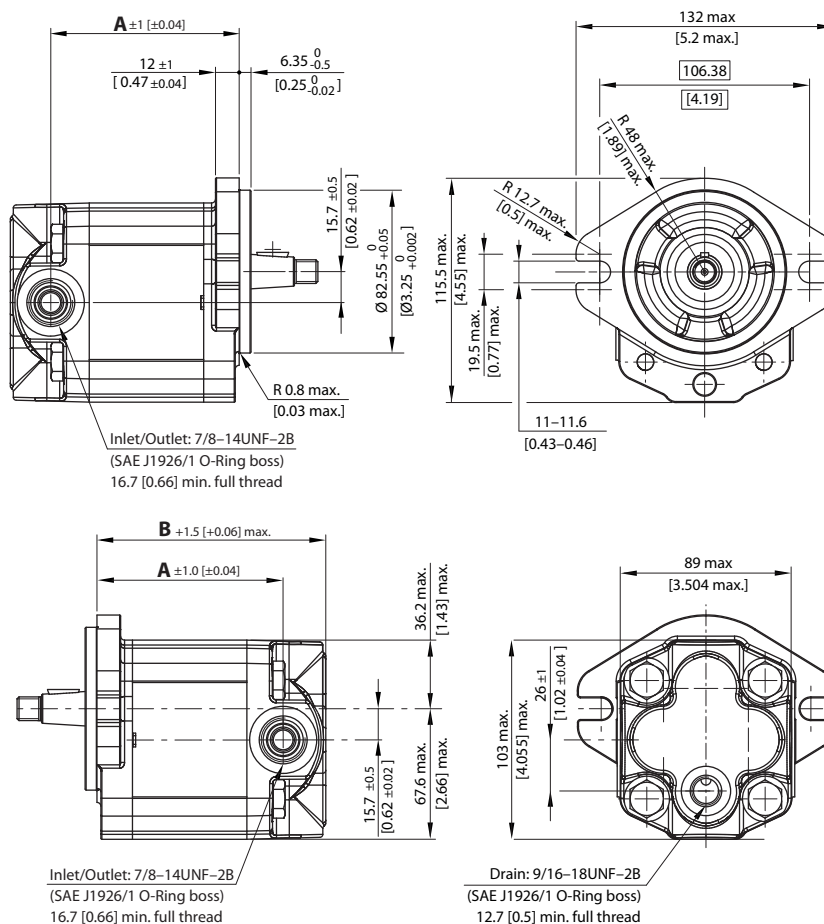

SGM2NC – 06BA dimensions

Dimension	Frame size						
	8,0	011	014	017	019	022	025
A	95.5 [3.76]	99.5 [3.92]	105.5 [4.15]	109.5 [4.31]	113.5 [4.47]	119.5 [4.70]	123.5 [4.86]
B	116 [4.57]	120 [4.72]	126 [4.96]	130 [5.11]	134 [5.28]	140 [5.51]	144 [5.67]
Inlet/Outlet	7/8-14UNF-2B (SAE J1926/1, O-Ring boss); 16.7 [0.66] min. full thread						
Drain port	9/16-18UNF-2B (SAE J1926/1 O-Ring boss); 12.7 [0.5] min. full thread						

SGM2NC Fan Drive Motors (Group 2)

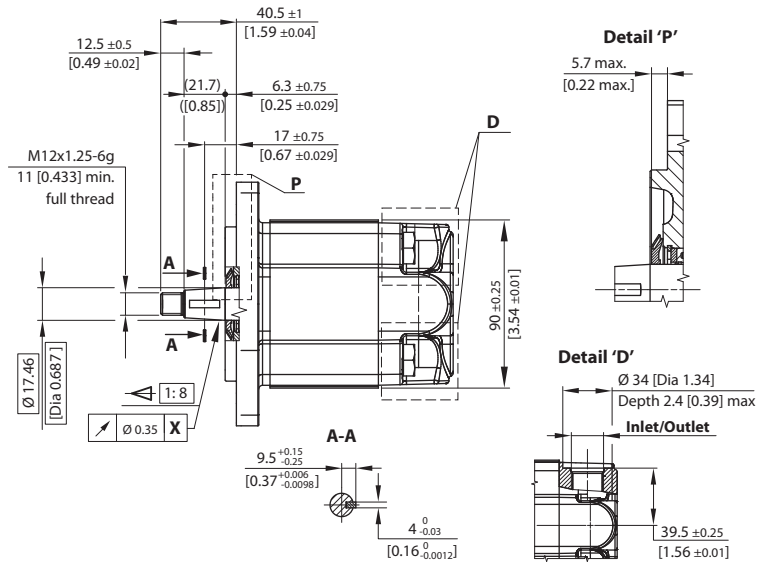

SGM2NC Fan Drive Motors (Group 2)

SGM2NC 06GB Dimensions

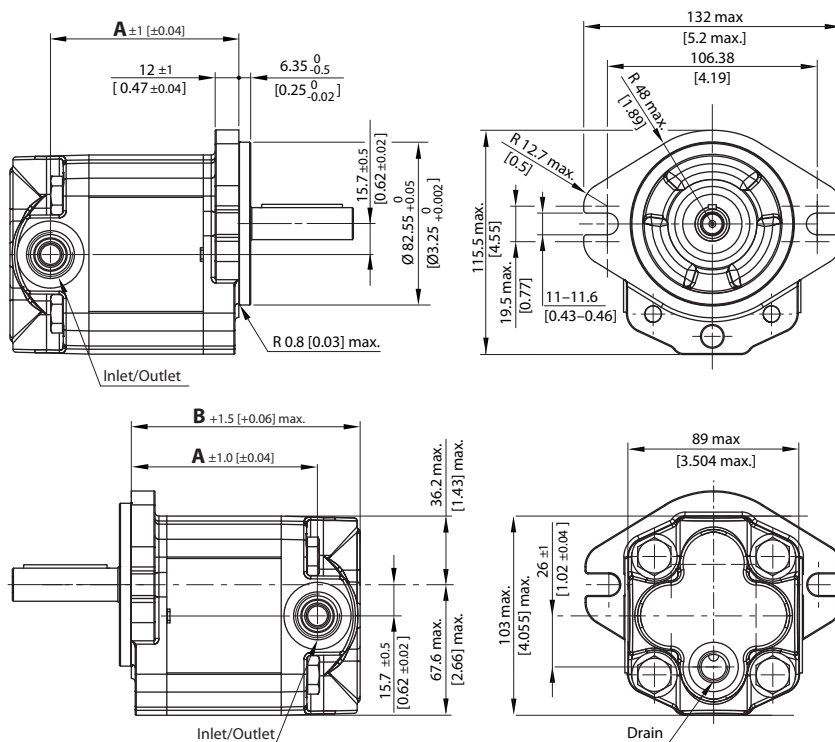

SGM2NC – 06BA dimensions

Dimension	Frame size						
	8,0	011	014	017	019	022	025
A	95.5 [3.76]	99.5 [3.92]	105.5 [4.15]	109.5 [4.31]	113.5 [4.47]	119.5 [4.70]	123.5 [4.86]
B	116 [4.57]	120 [4.72]	126 [4.96]	130 [5.11]	134 [5.28]	140 [5.51]	144 [5.67]
Inlet/Outlet	7/8–14UNF–2B (SAE J1926/1, O-Ring boss); 16.7 [0.66] min. full thread						
Drain port	9/16–18UNF–2B (SAE J1926/1 O-Ring boss); 12.7 [0.5] min. full thread						

SGM2YN Fan Drive Motors (Group 2)

SGM2YN is Group 2 fan drive motor with inlet on rear cover and outlet on body. Integrated proportional relief valve, anti-cavitation check valve and axial drain line.

Group 2 fan drive motors are available in displacements from 8.4 cm³/rev [0.51 in³/rev] to 25 cm³/rev [1.54 in³/rev].

Configurations include European and SAE flanges; taper 1:8, 1:5, and straight shafts Ø15.875 mm [0.62 in].

Outrigger bearing available as SAE A flange with taper shaft 1:8 and European flange with taper shaft 1:5.

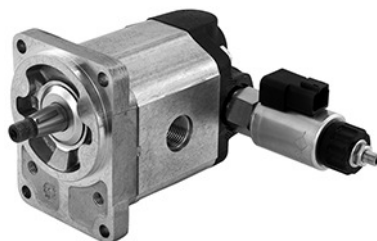
SGM2YN Technical Data

	Units	Frame size						
		8.0	011	014	017	019	022	025
Displacement	cm ³ /rev [in ³ /rev]	8.4 [0.51]	10.8 [0.66]	14.4 [0.88]	16.8 [1.03]	19.2 [1.17]	22.8 [1.39]	25.2 [1.54]
Peak pressure	bar [psi]	270 [3916]	270 [3916]	270 [3916]	250 [3626]	230 [3336]	200 [2900]	180 [2610]
Rated pressure		250 [3626]	250 [3626]	250 [3626]	230 [3336]	210 [3046]	180 [2610]	160 [2320]
Back pressure		150 [2176]	150 [2176]	150 [2176]	150 [2176]	130 [1885]	100 [1450]	100 [1450]
Maximum speed	min ⁻¹ [rpm]	3500	3500	3500	3500	3200	3200	3200
Minimum speed		700	700	700	500	500	500	500
Weight	kg [lb]	4.73 [10.43]	4.83 [10.65]	5.03 [11.1]	5.18 [11.42]	5.23 [11.53]	5.33 [11.75]	5.53 [12.2]
Moment of inertia of rotating components	x 10 ⁻⁶ kg·m ² [x 10 ⁻⁶ lbf·ft ²]	32.4 [796]	38.4 [911]	47.3 [1122]	53.3 [1265]	59.2 [1405]	68.1 [1616]	74.1 [1758]

SGM2YN Model Code Examples

Model code examples with maximum shaft torque

Flange/shaft	Model code example	Maximum shaft torque
02AA	SGM2YN/014LA02AAY6NNE5NNNN/XNNNN	140 N·m [1239 lb·in]
06BA	SGM2YN/025RA06BAY6NNE6NNNN/XNNNN	150 N·m [1328 lb·in]
06GB	SGM2YN/022L406GBY6NNE6NNNN/XNNNN	80 N·m [708 lb·in]

For further details on ordering, see [Model Code for Group 2 Fan Drive Motors](#) on page 17.

SGM2YN Fan Drive Motors (Group 2)

SGM2YN Electric Proportional Relief Valve Data

Electric Proportional Relief Valve use DEUTSCH DT 04-2P connector with protection rate IP 69K per DIN 40050.

Relief valve – Standard

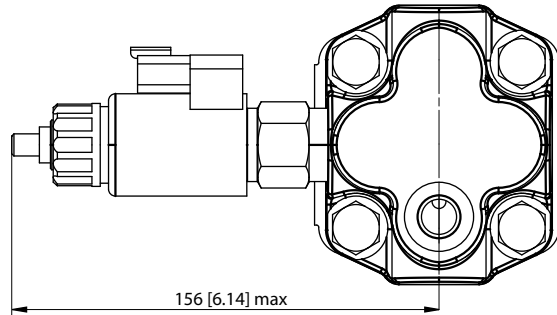

Relief valve with flat curve

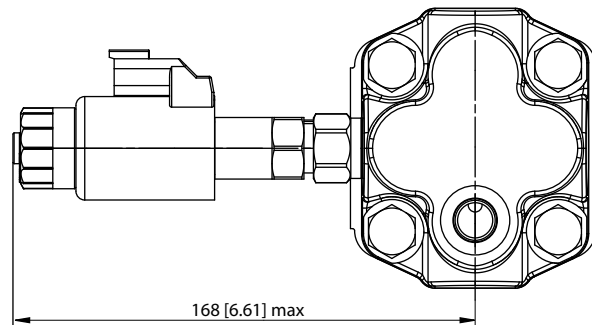

Description	Standard	Flat Curve
PWM frequency range	100 to 200 Hz	100 to 250 Hz
Supply 0 to 1.1 A @ 12 V _{DC}	Coil resistance of 7.2 Ω @ 20 °C [68 °F]	Coil resistance of 6.4 Ω @ 20 °C [68 °F]
Supply 0 to 0.55 A @ 24 V _{DC}	Coil resistance of 28.8 Ω @ 20 °C [68 °F]	Coil resistance of 26.2 Ω @ 20 °C [68 °F]

SGM2YN Fan Drive Motors (Group 2)

SGM2YN 02AA Dimensions

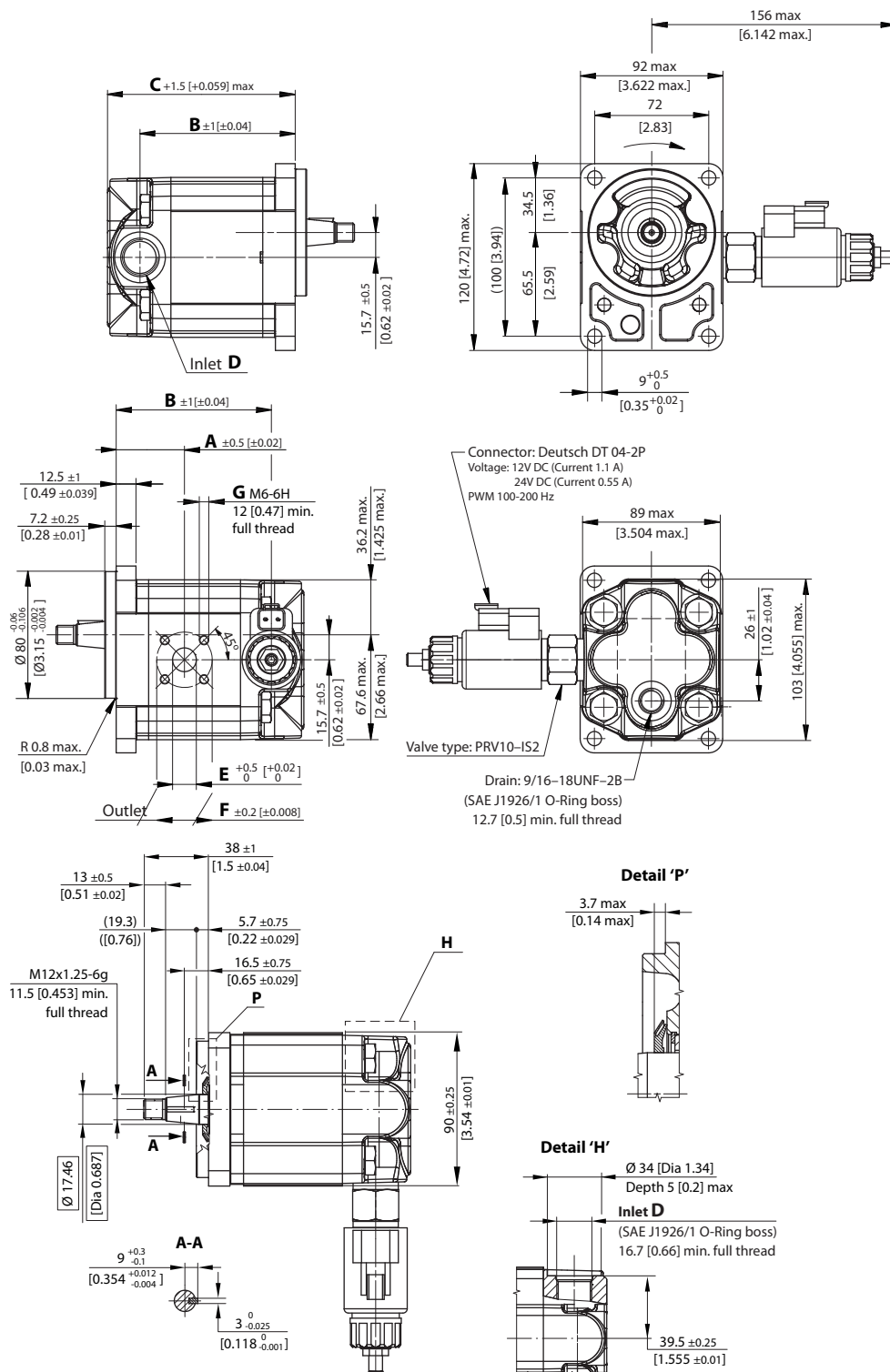

SGM2YN Fan Drive Motors (Group 2)
SGM2YN – 02AA dimensions

Dimension	Frame size						
	8,0	011	014	017	019	022	025
A	43.1 [1.70]	47.5 [1.87]	47.5 [1.87]	47.5 [1.87]	47.5 [1.87]	55.0 [2.17]	64.5 [2.54]
B	98 [3.86]	102 [4.01]	108 [4.25]	112 [4.41]	116 [4.57]	122 [4.80]	126 [4.96]
C	118.5 [4.66]	122.5 [4.83]	128.5 [5.05]	132.5 [5.22]	136.5 [5.37]	142.5 [5.61]	146.5 [5.77]
D	7/8–14UNF–2B (SAE J1926/1, O-Ring boss); 16.7 [0.66] min. full thread						
E	15 [0.59]		20 [0.79]				
F	35 [0.38]		40 [0.57]				
G	M6–6H; 12 [0.47] min. full thread						
Drain port	9/16–18UNF–2B (SAE J1926/1 O-Ring boss); 12.7 [0.5] min. full thread						

SGM2YN Fan Drive Motors (Group 2)

SGM2YN 06BA Dimensions

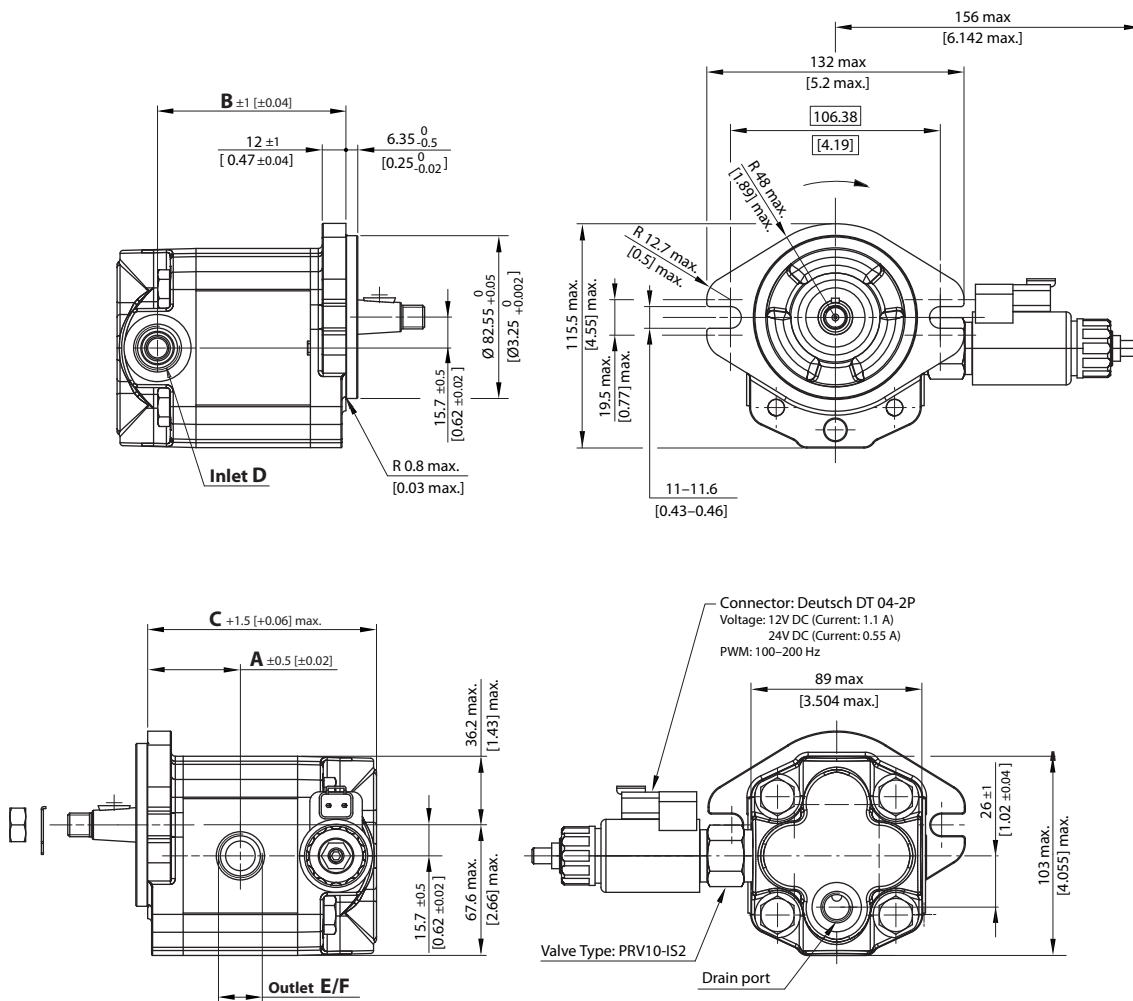

SGM2YN – 06GB dimensions

Dimension	Frame size						
	8,0	011	014	017	019	022	025
A	47 [1.85]	49 [1.93]	52 [2.05]	54 [2.13]	56 [2.21]	59 [2.32]	61 [2.40]
B	95.5 [3.76]	99.5 [3.92]	105.5 [4.15]	109.5 [4.31]	113.5 [4.47]	119.5 [4.70]	123.5 [4.86]
C	116 [4.57]	120 [4.72]	126 [4.96]	130 [5.11]	134 [5.28]	140 [5.51]	144 [5.67]
D	7/8-14UNF-2B (SAE J1926/1, O-Ring boss); 16.7 [0.66] min. full thread						
E/F	7/8-14UNF-2B (SAE J1926/1, O-Ring boss); 16.7 [0.66] min. full thread				1-1/16-12UN-2B (SAE J1926/1, O-Ring boss); 19 [0.75] min. full thread		
Drain	9/16-18UNF-2B (SAE J1926/1 O-Ring boss); 12.7 [0.5] min. full thread						

SGM2YN Fan Drive Motors (Group 2)

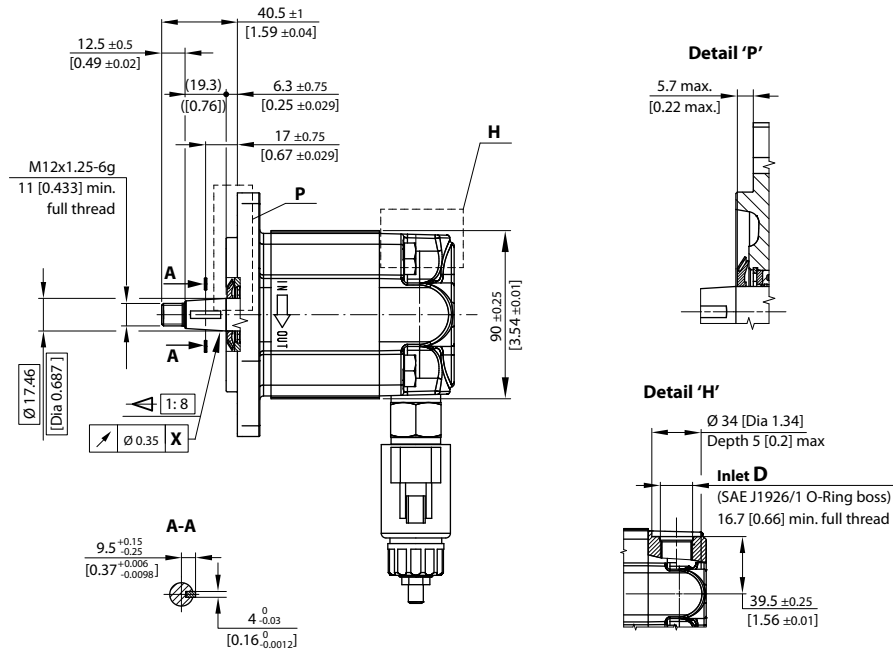

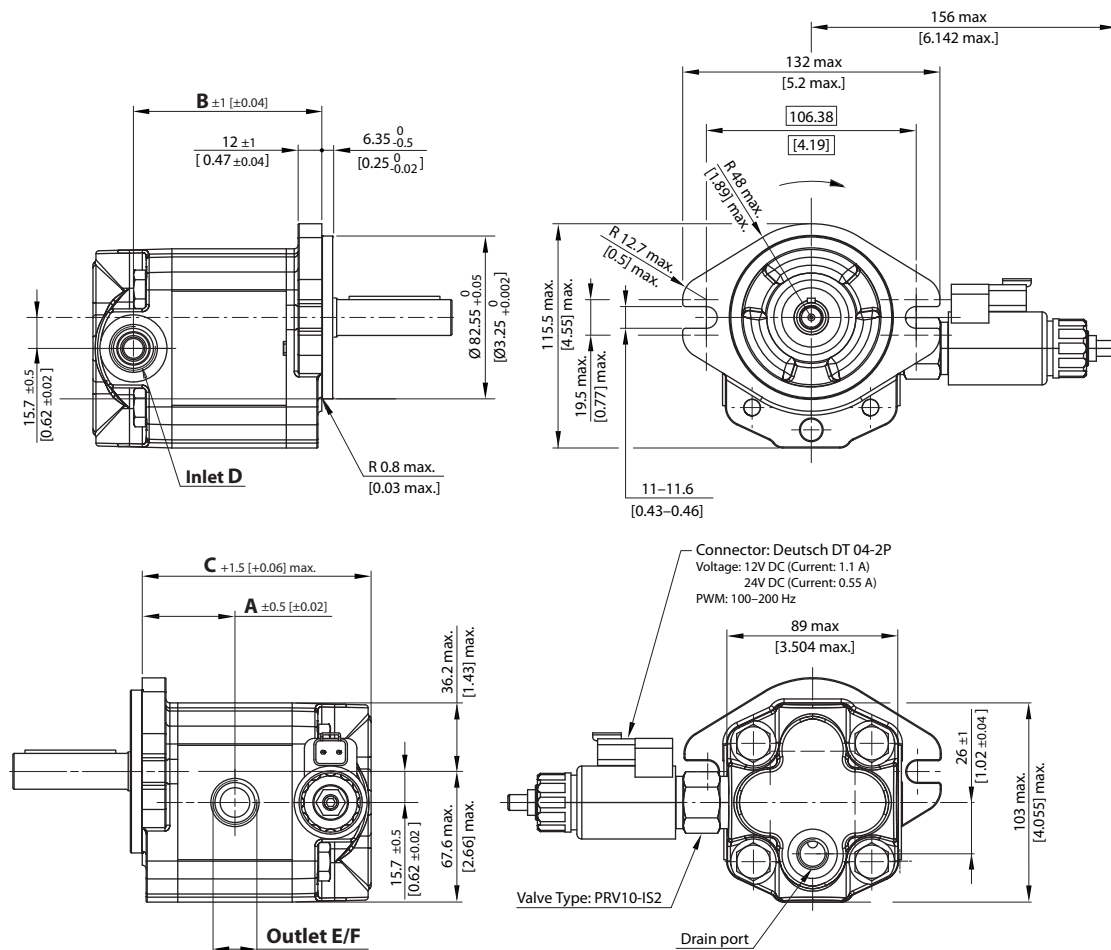
SGM2YN Fan Drive Motors (Group 2)
SGM2YN 06GB Dimensions

SGM2YN – 06GB dimensions

Dimension	Frame size						
	8,0	011	014	017	019	022	025
A	47 [1.85]	49 [1.93]	52 [2.05]	54 [2.13]	56 [2.21]	59 [2.32]	61 [2.40]
B	95.5 [3.76]	99.5 [3.92]	105.5 [4.15]	109.5 [4.31]	113.5 [4.47]	119.5 [4.70]	123.5 [4.86]
C	116 [4.57]	120 [4.72]	126 [4.96]	130 [5.11]	134 [5.28]	140 [5.51]	144 [5.67]
D	7/8–14UNF–2B (SAE J1926/1, O-Ring boss); 16.7 [0.66] min. full thread						
E/F	7/8–14UNF–2B (SAE J1926/1, O-Ring boss); 16.7 [0.66] min. full thread				1–1/16–12UN–2B (SAE J1926/1, O-Ring boss); 19 [0.75] min. full thread		
Drain	9/16–18UNF–2B (SAE J1926/1 O-Ring boss); 12.7 [0.5] min. full thread						

SGM2YN Fan Drive Motors (Group 2)

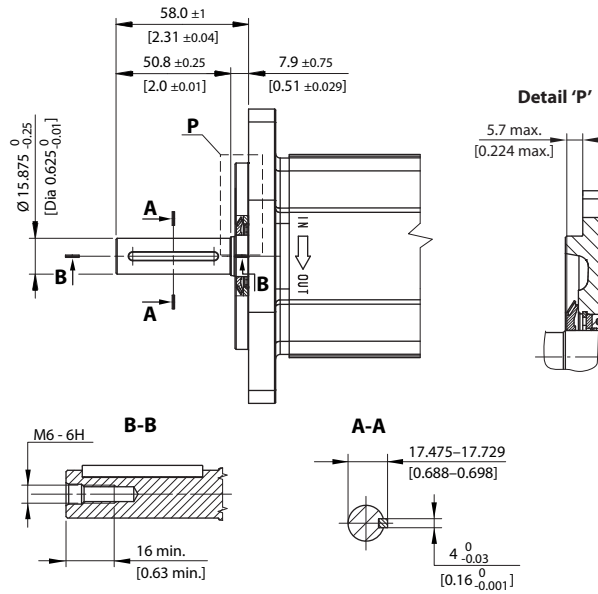

SGM2YN Fan Drive Motors (Group 2)

SGM2YN Outrigger Bearing Dimensions

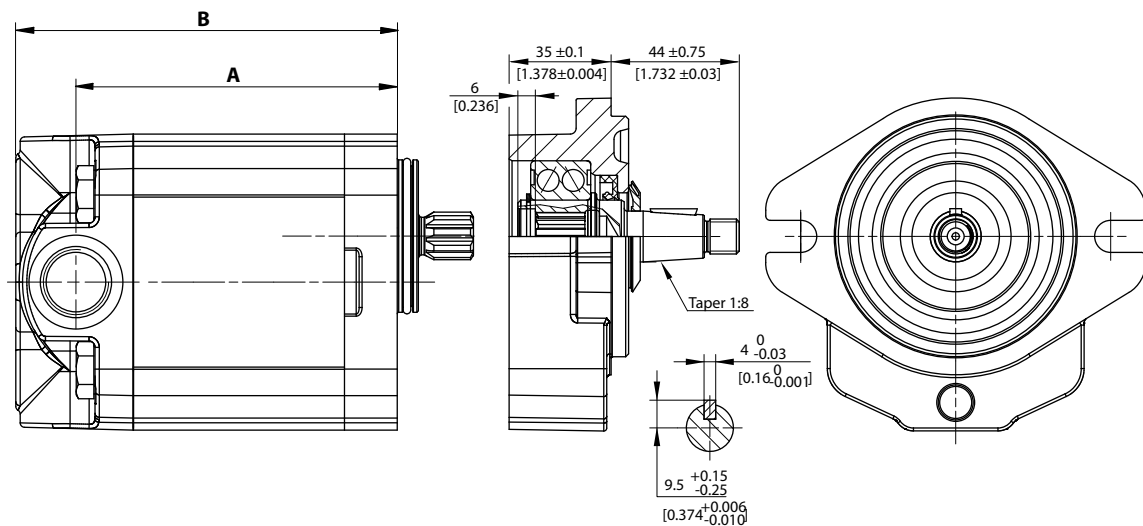

Dimension	Frame size						
	8,0	011	014	017	019	022	025
A	95.5 [3.76]	99.5 [3.92]	105.5 [4.15]	109.5 [4.31]	113.5 [4.47]	119.5 [4.70]	123.5 [4.86]
B	116 [4.66]	120 [4.83]	126 [5.05]	130 [5.22]	134 [5.37]	140 [5.61]	144 [5.77]

SGM2VC Fan Drive Motors (Group 2)

SGM2VC is Group 2 fan drive motor with integrated DCV valve for “reverse function”, anti-shock and proportional relief valve. Inlet/outlet and radial drain line are on cast iron rear cover.

Displacement range from 8.4 up to 25.2 cm³/rev [from 0.51 up to 1.54 in³/rev].

Configurations include European and SAE flanges; taper 1:8, taper 1:5 and parallel Ø15.875 mm [Dia 0.62 in] shafts.

Outtrigger bearing available as SAE A flange with taper shaft 1:8 and European flange with taper shaft 1:5.

SGM2VC 9YBA Outtrigger bearing with dust cover

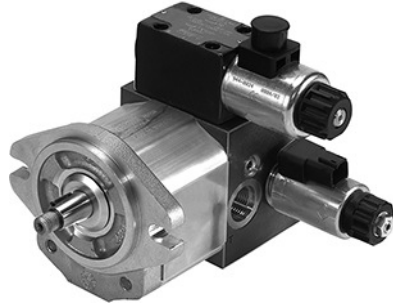
SGM2VC Technical Data

	Units	Frame size						
		8.0	011	014	017	019	022	025
Displacement	cm ³ /rev [in ³ /rev]	8.4 [0.51]	10.8 [0.66]	14.4 [0.88]	16.8 [1.03]	19.2 [1.17]	22.8 [1.39]	25.2 [1.54]
Peak pressure	bar [psi]	270 [3916]	270 [3916]	270 [3916]	250 [3626]	230 [3336]	200 [2900]	180 [2610]
Rated pressure		250 [3626]	250 [3626]	250 [3626]	230 [3336]	210 [3046]	180 [2610]	160 [2320]
Back pressure		150 [2176]	150 [2176]	150 [2176]	150 [2176]	130 [1885]	100 [1450]	100 [1450]
Maximum speed	min ⁻¹ [rpm]	3500	3500	3500	3500	3200	3200	3200
Minimum speed		700	700	700	500	500	500	500
Weight	kg [lb]	8.41 [18.54]	8.96 [19.75]	9.11 [20.08]	9.26 [20.41]	9.36 [20.63]	9.51 [20.96]	9.61 [21.19]
Moment of inertia of rotating components	x 10 ⁻⁶ kg·m ² [x 10 ⁻⁶ lbf·ft ²]	32.4 [796]	38.4 [911]	47.3 [1122]	53.3 [1265]	59.2 [1405]	68.1 [1616]	74.1 [1758]

SGM2VC Model Code Examples

Model code examples with maximum shaft torque

Flange/shaft	Model code example	Maximum shaft torque
02AA	SGM2VC/014LA02AARANNNNNNN/XASNN	140 N·m [1239 lb·in]
06BA	SGM2VC/014LA06BARANNNNNNN/XASNN	150 N·m [1328 lb·in]
06GB	SGM2VC/014RA06GBRANNNNNNN/SASNN	80 N·m [708 lb·in]

[For further details on ordering, see Model Code for Group 2 Fan Drive Motors on page 17.](#)

SGM2VC Fan Drive Motors (Group 2)

SGM2VC Electric Proportional Relief and D03 Directional Valves Data

Electric Proportional Relief Valve and Directional Valve (D03) use DEUTSCH DT 04-2P connector with protection rate IP 69K per DIN 40050.

Relief and directional valve – Standard

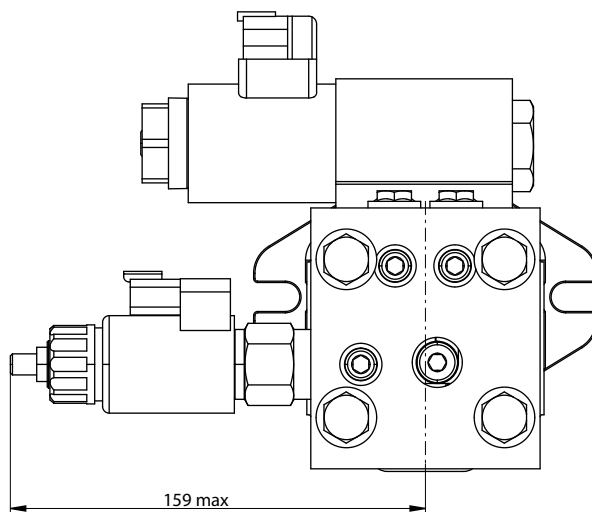

Relief valve and D03 directional valve with flat curve

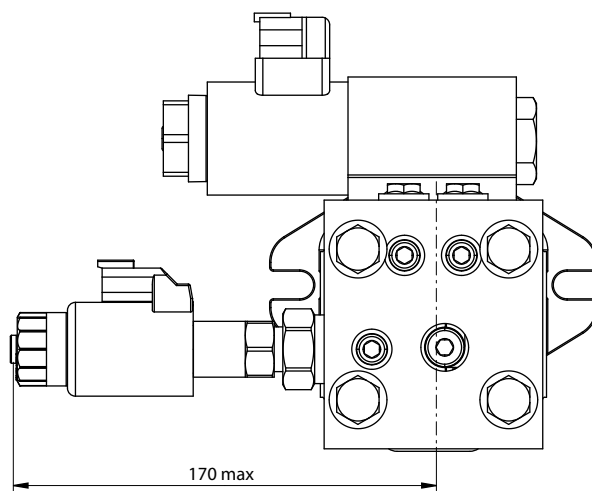

Description	Standard	Flat Curve
PWM frequency range	100 to 200 Hz	100 to 250 Hz
Supply 0 to 1.1 A @ 12 V _{DC}	Coil resistance of 7.2 Ω @ 20 °C [68 °F]	Coil resistance of 6.4 Ω @ 20 °C [68 °F]
Supply 0 to 0.55 A @ 24 V _{DC}	Coil resistance of 28.8 Ω @ 20 °C [68 °F]	Coil resistance of 26.2 Ω @ 20 °C [68 °F]

SGM2VC Fan Drive Motors (Group 2)

SGM2VC 02AA Dimensions

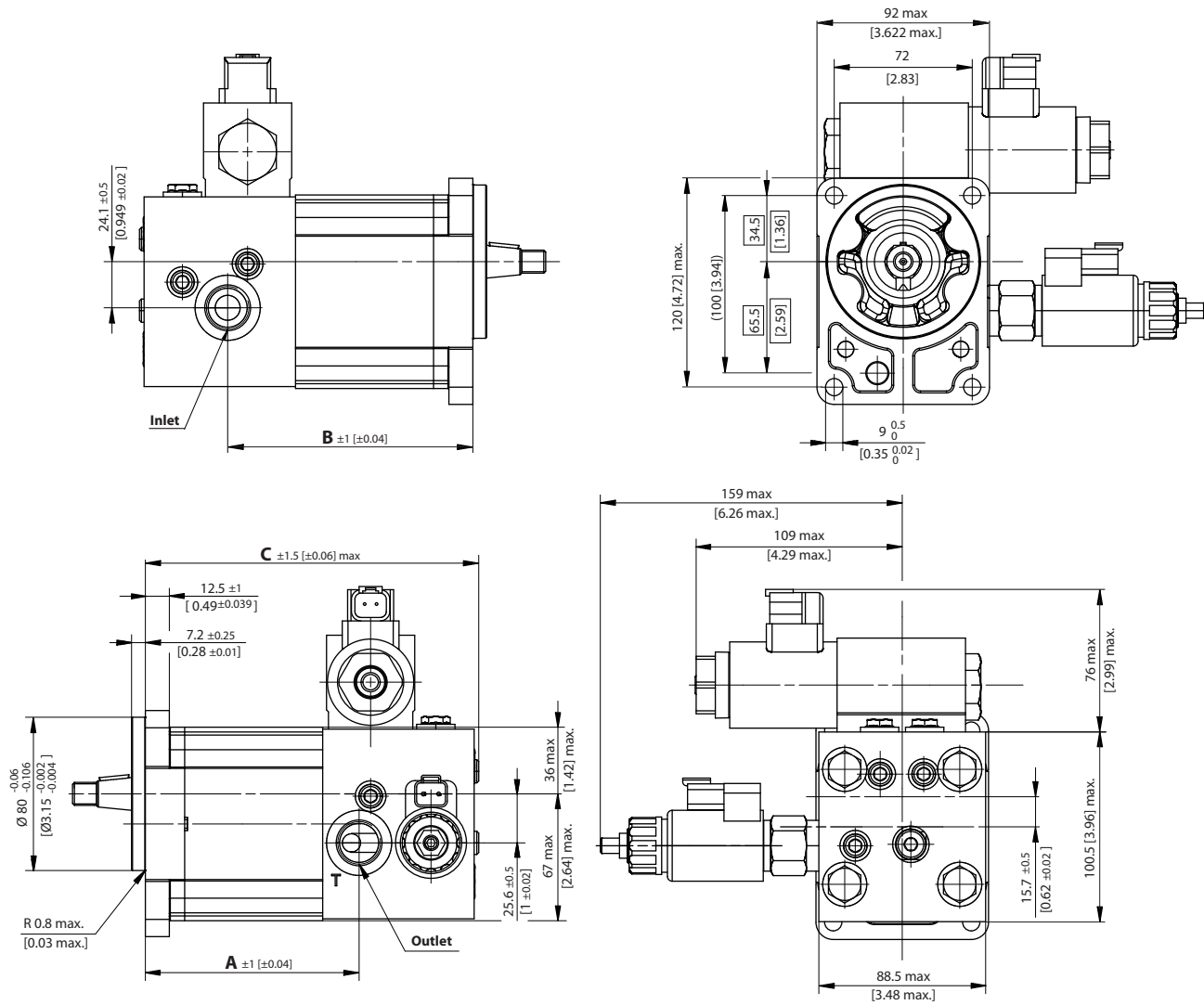

SGM2VC – 02AA dimensions

Dimension	Frame size						
	8,0	011	014	017	019	022	025
A	97.5 [3.84]	101.5 [4.0]	107.5 [4.23]	111.5 [4.39]	115.5 [4.55]	121.5 [4.78]	125.5 [4.94]
B	114 [4.49]	118 [4.65]	124 [4.88]	128 [5.04]	132 [5.20]	138 [5.43]	142 [5.59]
C	160 [6.30]	164 [6.46]	170 [6.69]	174 [6.85]	178 [7.0]	184 [7.24]	188 [7.40]
D	98.5 [3.88]	102.5 [4.04]	108.5 [4.27]	112.5 [4.43]	116.5 [4.59]	122.5 [4.82]	126.5 [4.98]
Inlet/Outlet	7/8–14UNF–2B (SAE J1926/1, O-Ring boss); 16.7 [0.66] min. full thread						
Drain port	9/16–18UNF–2B (SAE J1926/1 O-Ring boss); 12.7 [0.5] min. full thread						

SGM2VC Fan Drive Motors (Group 2)

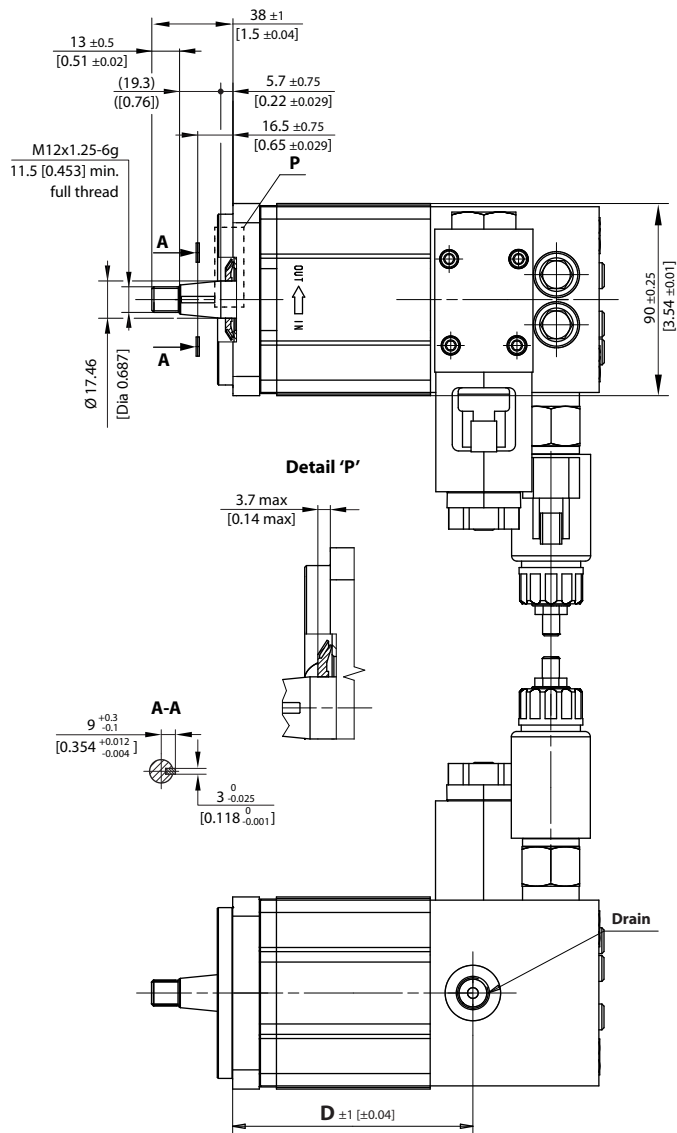

SGM2VC Fan Drive Motors (Group 2)

SGM2VC 06BA Dimensions

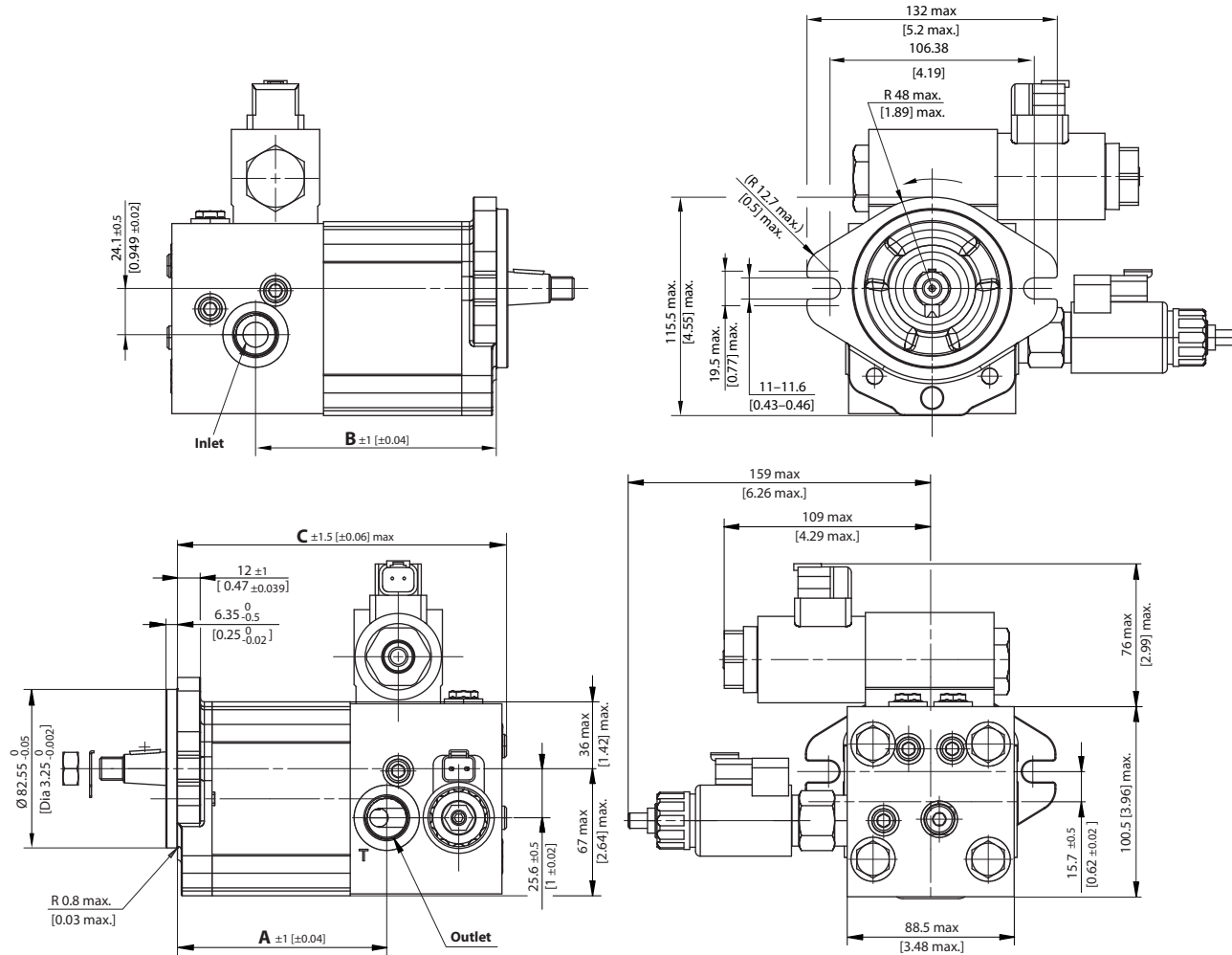

SGM2VC – 06BA dimensions

Dimension	Frame size						
	8,0	011	014	017	019	022	025
A	95 [3.74]	99 [3.9]	105 [4.13]	109 [4.29]	113 [4.45]	119 [4.69]	123 [4.84]
B	114.4 [4.45]	115.4 [4.54]	121.4 [4.78]	125.4 [4.94]	129.4 [5.09]	135.4 [5.33]	139.4 [5.49]
C	157.4 [6.20]	161.4 [6.35]	167.4 [6.59]	171.4 [6.75]	175.4 [6.90]	181.4 [7.14]	185.4 [7.30]
D	96 [3.78]	100 [3.94]	106 [4.17]	110 [4.33]	114 [4.49]	120 [4.72]	124 [4.88]
Inlet/Outlet	7/8–14UNF–2B (SAE J1926/1, O-Ring boss); 16.7 [0.66] min. full thread						
Drain port	9/16–18UNF–2B (SAE J1926/1 O-Ring boss); 12.7 [0.5] min. full thread						

SGM2VC Fan Drive Motors (Group 2)

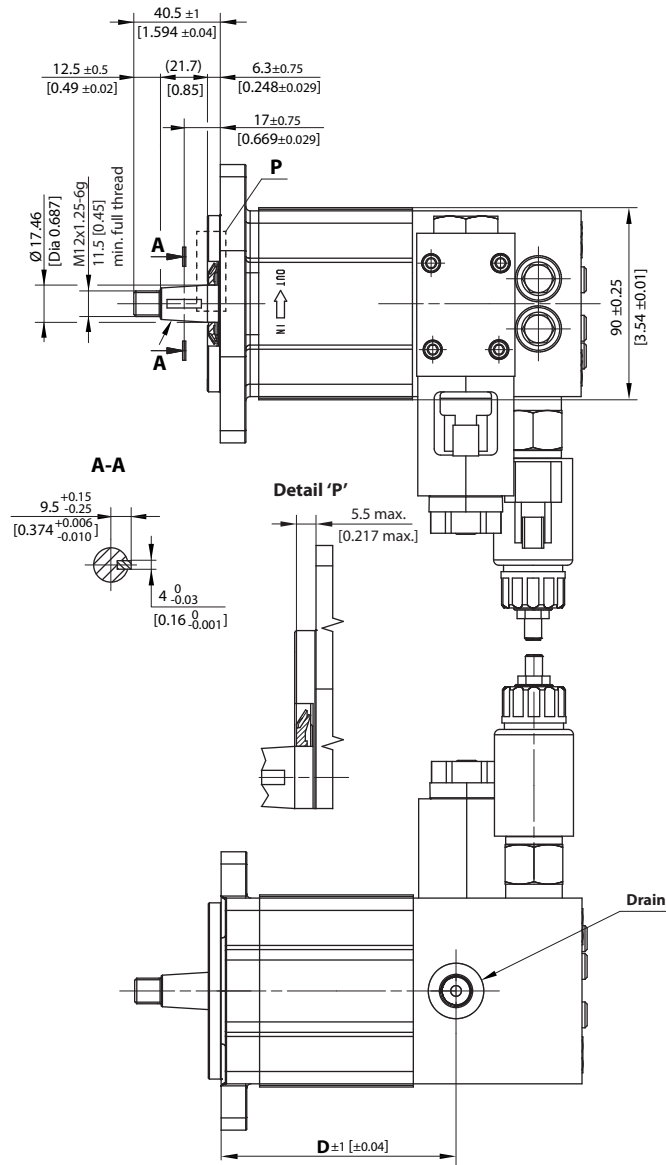

SGM2VC Fan Drive Motors (Group 2)

SGM2VC 06GB Dimensions

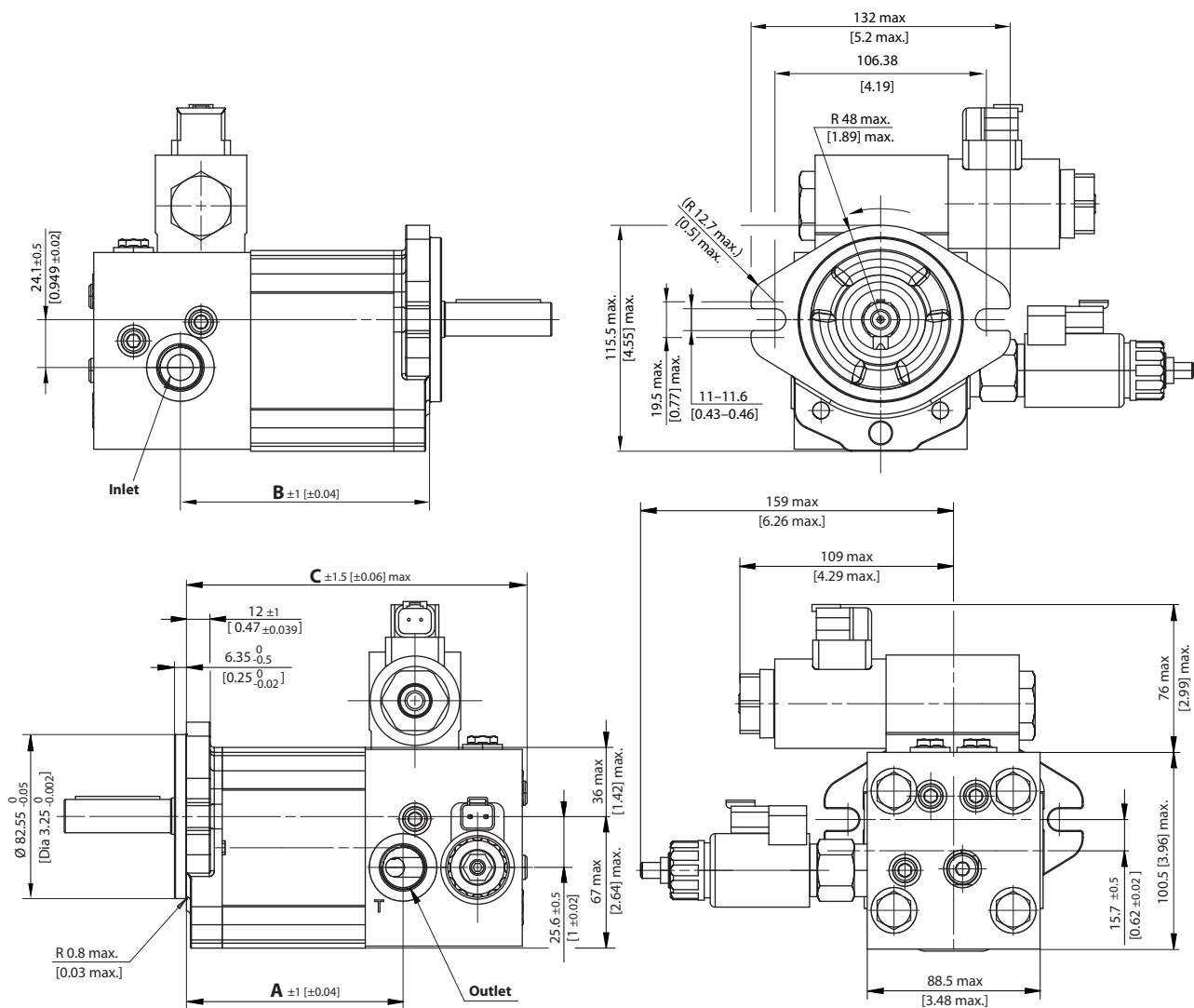

SGM2VC – 06GB dimensions

Dimension	Frame size						
	8,0	011	014	017	019	022	025
A	95 [3.74]	99 [3.9]	105 [4.13]	109 [4.29]	113 [4.45]	119 [4.69]	123 [4.84]
B	114.4 [4.45]	115.4 [4.54]	121.4 [4.78]	125.4 [4.94]	129.4 [5.09]	135.4 [5.33]	139.4 [5.49]
C	157.4 [6.20]	161.4 [6.35]	167.4 [6.59]	171.4 [6.75]	175.4 [6.90]	181.4 [7.14]	185.4 [7.30]
D	96 [3.78]	100 [3.94]	106 [4.17]	110 [4.33]	114 [4.49]	120 [4.72]	124 [4.88]
Inlet/Outlet	7/8–14UNF–2B (SAE J1926/1, O-Ring boss); 16.7 [0.66] min. full thread						
Drain port	9/16–18UNF–2B (SAE J1926/1 O-Ring boss); 12.7 [0.5] min. full thread						

SGM2VC Fan Drive Motors (Group 2)

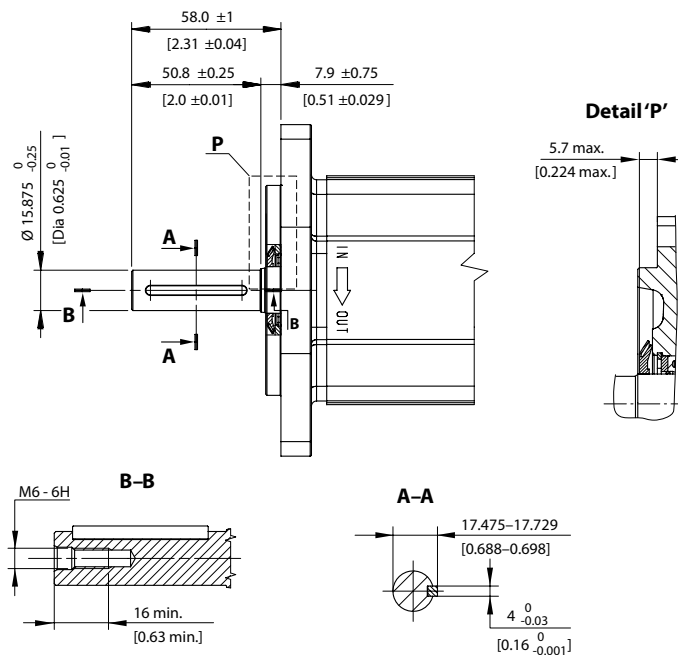

SGM2VC Fan Drive Motors (Group 2)

SGM2VC Outrigger Bearing Dimensions

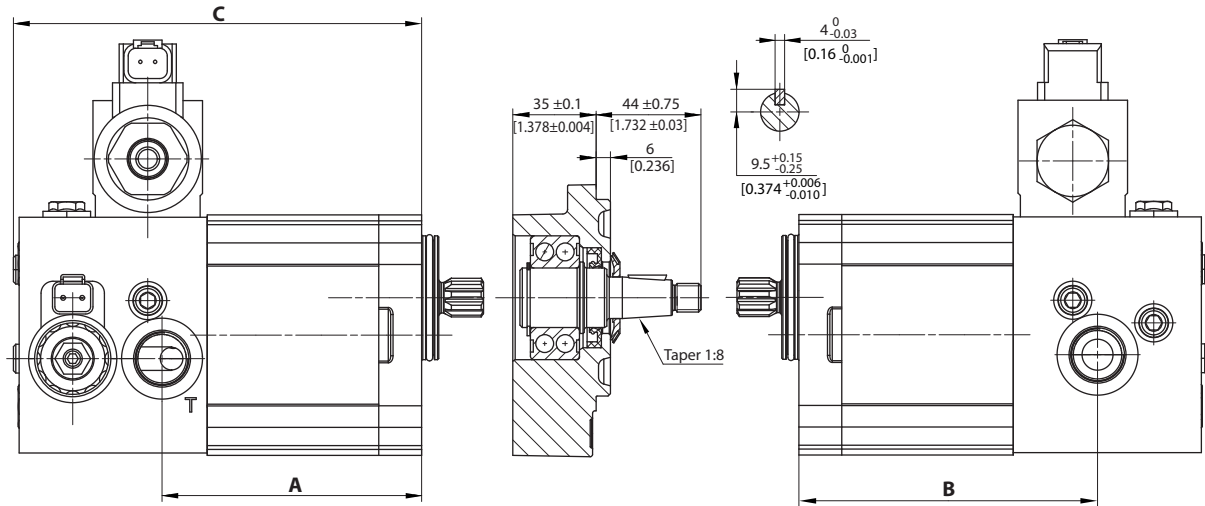

Dimension	Frame size						
	8,0	011	014	017	019	022	025
A	95 [3.74]	99 [3.90]	105 [4.13]	109 [4.29]	113 [4.45]	119 [4.69]	123 [4.84]
B	111.4 [4.39]	115.4 [4.54]	121.4 [4.78]	125.4 [4.94]	129.4 [5.09]	135.4 [5.33]	139.4 [5.49]
C	157.4 [6.20]	161.4 [6.35]	167.4 [6.59]	171.4 [6.75]	175.4 [6.90]	181.4 [7.14]	185.4 [7.30]

Group 3
Model Code for Group 3 Fan Drive Motors

A – Family

SGM3NC	Fan Drive Bi-directional Motor; External Axial Drain
SGM3GC	Fan Drive Uni-directional Motor; Anti-cavitation Check valve
SGM3YN	Fan Drive Motor with Proportional Pressure Valve, Axial Drain
SGM3YL	Fan Drive Motor with Proportional Pressure Valve, Radial Drain
SGM3VC	Reversible Fan Drive Motor with Proportional Pressure Valve

B – Frame size and displacement

022	22.1 cm ³
026	26.2 cm ³
033	33.1 cm ³
038	37.9 cm ³
044	44.1 cm ³

C – Direction of rotation

B	Bi-directional (SGM3NC) or Uni-directional (SGM3GC)
L	Left hand (Counter-clockwise)
R	Right hand (Clockwise)

D – Project version

A	High temperature sealing, dust protector, rust protected screws
----------	---

E – Mounting flange

01	European 01: Pilot Ø50.8 mm; 4 holes (98.4 x 128.1)
07	SAE B: Pilot Ø101.6 mm; 2 holes,
91	Outrigger bearing flange 01; M14x1.5 Key 4x7.5
9Y	SAE B: Pilot Ø101.6 mm; 2 holes; outrigger bearing with dust cover

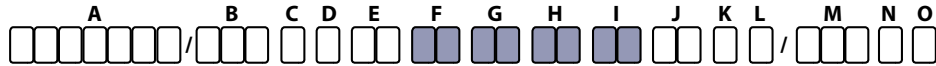
Group 3
Model Code for Group 3 Fan Drive Motors

F – Drive gear

BA	Taper 1:8; M14x1.5; Key 4 (Special for flange 01 and Outrigger Bearing 91)
BC	Taper 1:8; 5/8–18UNF–2A; Key 6.375
BP	Taper 1:8; 5/8–18UNF–2A; Key 6.375 with Nut and Washer (Special for SAE B flange)
GB	Parallel Ø22.225 x 25.4; Key 6.375 x 6.375 x 25.4 + thread hole: 1/4–20UNC–2B

For more details about configuration, see [Model Code for Mounting Flange/Drive Gears \(Group 3\)](#) on page 51.

G – Rear cover

C6	Cast iron cover: 1-1/16–12 UN; In/Out ports: 9/16–18 UNF–2B Axial Drain (idler gear side)
CX	Cast iron cover: 1-1/16–12 UN; In/Out ports: 9/16–18 UNF–2B Radial Drain (idler gear side)
CZ	Cast iron cover: 1-1/16–12 UN; In/Out ports: 9/16–18 UNF–2B Radial Drain (shaft side)
Y6	Cast iron cover: 1-1/16–12 UN; In port: 9/16–18 UNF–2B Axial Drain (idler gear side)
Y4	Cast iron cover: 1-1/16–12 UN; In port: 9/16–18 UNF–2B Radial Drain (idler gear side)
YX	Cast iron cover: 1-1/16–12 UN; In port: 9/16–18 UNF–2B Radial Drain (shaft side)
RA	Proportional PRV Reversing Valve Cover, 12 V_{DC} V03 DEUTSCH connector, Anti-Shock-MakeUp Valve, 1-1/16–12 UN Work Ports, 9/16–18 UNF Radial Drain Port
RB	Proportional PRV Reversing Valve Cover, 24 V_{DC} V03 DEUTSCH connector, Anti-Shock-MakeUp Valve, 1-1/16–12 UN Work Ports, 9/16–18 UNF Radial Drain Port

H – Inlet ports

NN	Without inlet on body
-----------	-----------------------

I – Outlet ports

Code	Dimensions	Ports	Code	Thread Dimensions
A3	25x26,19x52,37x3/8-16UNC		E6	1 ¹ / ₁₆ –12UN
M5	25x52.37x26.19xM10		E8	1 ⁵ / ₁₆ –12UN
M6	31x30.18x58.72xM10		E9	1 ⁵ / ₈ –12UN
M7	37.5x35.71x69.85xM12		E1	1 ⁷ / ₈ –12UN
C7	20x40xM8		F5	BSP 3/4 Gas
CA	27x51xM10		F6	BSP 1 Gas
BB	27x55xM8		F7	BSP 1-1/4 Gas
NN	Without outlet on body		H8	M27x2 per ISO6149

Group 3

Model Code for Group 3 Fan Drive Motors



J – Ports positions and special body

NN	Standard from catalogue
-----------	-------------------------

K – Seals

N	Standard seals for high temperature
W	Standard seals for high temperature without dust cover

L – Screws

N	Rust protected screws
----------	-----------------------

M – Valve setting

NNN XNN	No valve
***	Integral relief valve pressure setting*

* For more details see [Model Code for Integral Relief Valve Pressure Setting](#) on page 50.

N – Type marking

N	Standard Danfoss marking
A	Standard Danfoss marking + Customer code
Z	No marking
*	Special customer marking

O – Marking position

N	Standard marking on the top
A	Special marking position at the bottom

Group 3

Model Code for Integral Relief Valve Pressure Setting



M – Valve setting

XNN	No valve	
XA*	Standard relief valve with coil voltage 12 V_{DC} , DT connector	
XB*	Standard relief valve with coil voltage 24 V_{DC} , DT connector	
X**	X*F	<p>Three color curves represent three types of valves. Each valve is characterized by different nominal spring ranges. Select requirements using the graph Pressure vs. Bypass flow below:</p> <p>The graph plots Δ Pressure (bar) on the y-axis (0 to 300) against Bypass flow (l/min) on the x-axis (0 to 160). It shows several curves: a black curve (F) starting at ~50 bar; a blue curve (I) starting at ~100 bar; a blue curve (M) starting at ~120 bar; a blue curve (O) starting at ~140 bar; a red curve (Q) starting at ~160 bar; a red curve (U) starting at ~180 bar; and a red curve (W) starting at ~200 bar. All curves show an upward trend as bypass flow increases.</p>
	X*I X*M X*O X*Q X*R X*S X*U X*W	

Group 3

Model Code for Mounting Flange/Drive Gears (Group 3)

Danfoss offers two types of industry standard mounting flange:

- **07** SAE B pilot Ø101.6 mm; 2 holes
- **9Y** Outrigger Bearing with dust cover; Taper 1:8; 5/8–18UNF; Key 6.375 mm

Spline configuration is not available for fan drive motors. Other shaft options may exist. Contact your Danfoss representative for availability. The table below shows order codes for each available mounting flange and shaft:

Model code sections: E and F

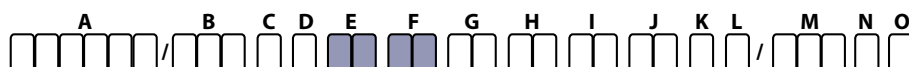

Mounting flange/Drive gear availability with max. torque

Mounting Flange			Drive Gear			
Code E	Description		Code F	Description	Maximum torque	
07	SAE B pilot Ø101.6 mm; 2 holes;		BC	Taper 1:8; 5/8–18UNF; Key 6.375 mm		300 N·m [2655 lbf·in]
			BP	Taper 1:8; 5/8–18UNF; Key 6.375 mm with washer and nut		
			GB	Parallel drive Ø 22.225; 25.4 mm long; Key 6.375 mm		
91	Outrigger Bearing with dust cover European pilot Ø 50.8 mm; 4 holes		BA	Tapered shaft thread M14x1.5; Key 4x7.5		350 N·m [3097 lbf·in]
9Y	Outrigger Bearing with dust cover SAE B pilot Ø101.6 mm; 2 holes		DA	Taper 1:8; 5/8–18UNF; Key 6.375 mm		

⚠ Caution

Shaft torque capability may limit allowable pressure. Torque ratings assume no external radial loading. Applied torque must not exceed these limits, regardless of stated pressure parameters. Maximum torque ratings are based on shaft torsional fatigue strength.

SGM3NC Fan Drive Motors (Group 3)

SGM3NC is Group 3 bidirectional fan drive motor with inlet/outlet on cast iron rear cover and axial drain line.

Displacement range from 22.1 cm³/rev up to 44.1 cm³/rev [from 1.34 in³/rev up to 2.69 in³/rev].

Configurations include European and SAE flanges; taper 1:8, taper 1:5 and parallel Ø15.875 mm [Dia 0.62 in] shafts.

Outrigger bearing available as SAE A flange with taper shaft 1:8 and European flange with taper shaft 1:5.

SGM3NC 01BC

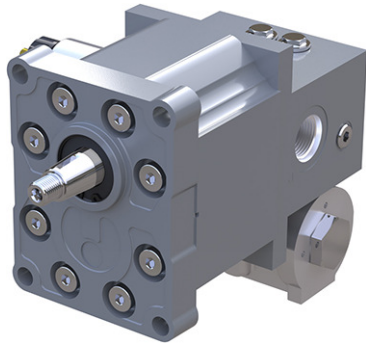

SGM3NC 9YDA

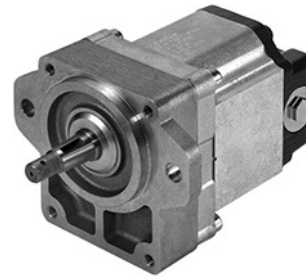
SGM3NC Technical Data

	Units	Frame size				
		022	026	033	038	044
Displacement	cm ³ /rev [in ³ /rev]	22.1 [1.34]	26.2 [1.60]	33.1 [2.02]	37.9 [2.31]	44.1 [2.69]
Peak pressure	bar [psi]	270 [3916]	270 [3916]	270 [3916]	270 [3916]	270 [3916]
Rated pressure		250 [3626]	250 [3626]	250 [3626]	250 [3626]	250 [3626]
Back pressure		250 [3626]	250 [3626]	250 [3626]	250 [3626]	250 [3626]
Maximum speed	min ⁻¹ [rpm]	2500	2500	2500	2500	2300
Minimum speed		800	800	800	800	800
Weight	kg [lb]	8.62 [19.0]	8.72 [19.23]	8.82 [19.45]	8.88 [19.58]	9.02 [19.89]
Moment of inertia of rotating components	x 10 ⁻⁶ kg·m ² [x 10 ⁻⁶ lbf·ft ²]	198 [4699]	216 [5126]	246 [5838]	267.2 [6341]	294.2 [6981]

SGM3NC Model Code Examples

Model code examples with maximum shaft torque

Flange/shaft	Model code example	Maximum shaft torque
07BC	SGM3NC/026BA07BCC6NNNNNNNN/NNNNN	300 N·m [2655 lb·in]
07GB	SGM3NC/026BA07GBC6NNNNNNNN/NNNNN	230 N·m [2036 lb·in]

[For further details on ordering, see Model Code for Group 3 Fan Drive Motors on page 47.](#)

SGM3NC Fan Drive Motors (Group 3)

SGM3NC 07BC Dimensions

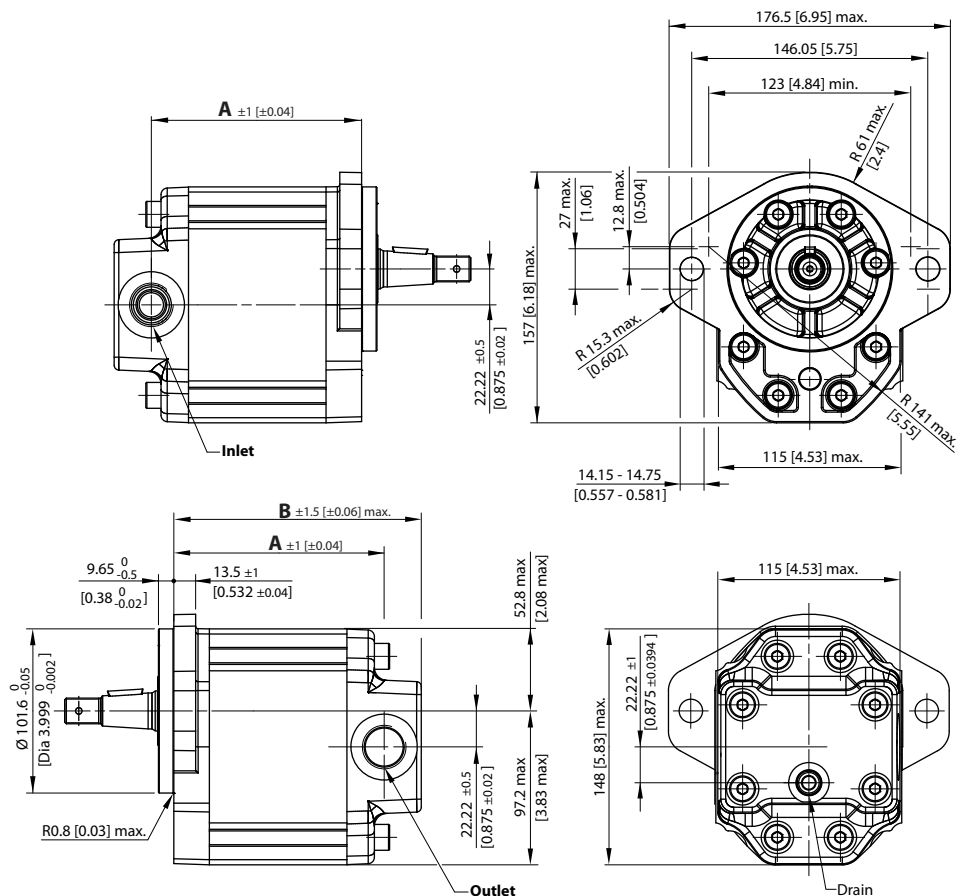

SGM3NC – 07BC dimensions

Dimension	Frame size				
	022	026	033	038	044
A	127.1 [5.04]	130.1 [5.12]	135.1 [5.32]	138.6 [5.46]	143.1 [5.63]
B	150.1 [5.91]	153.1 [6.03]	158.1 [6.22]	161.6 [6.36]	166.1 [6.54]
Inlet/Outlet	1-1/16-12UN-2B (SAE J1926/1, O-Ring boss); 19 [0.75] min. full thread				
Drain port	9/16-18UNF-2B (SAE J1926/1 O-Ring boss); 12.7 [0.5] min. full thread				

SGM3NC Fan Drive Motors (Group 3)

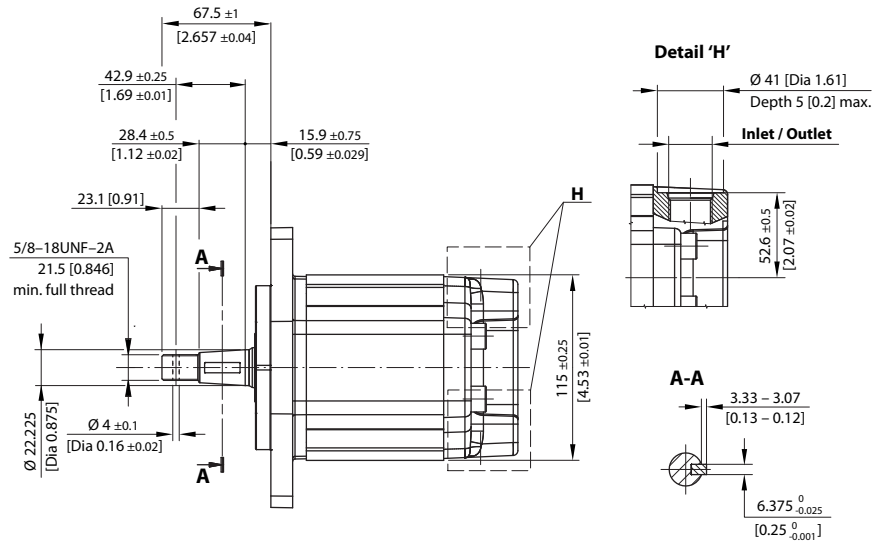

SGM3NC Fan Drive Motors (Group 3)

SGM3NC 07GB Dimensions

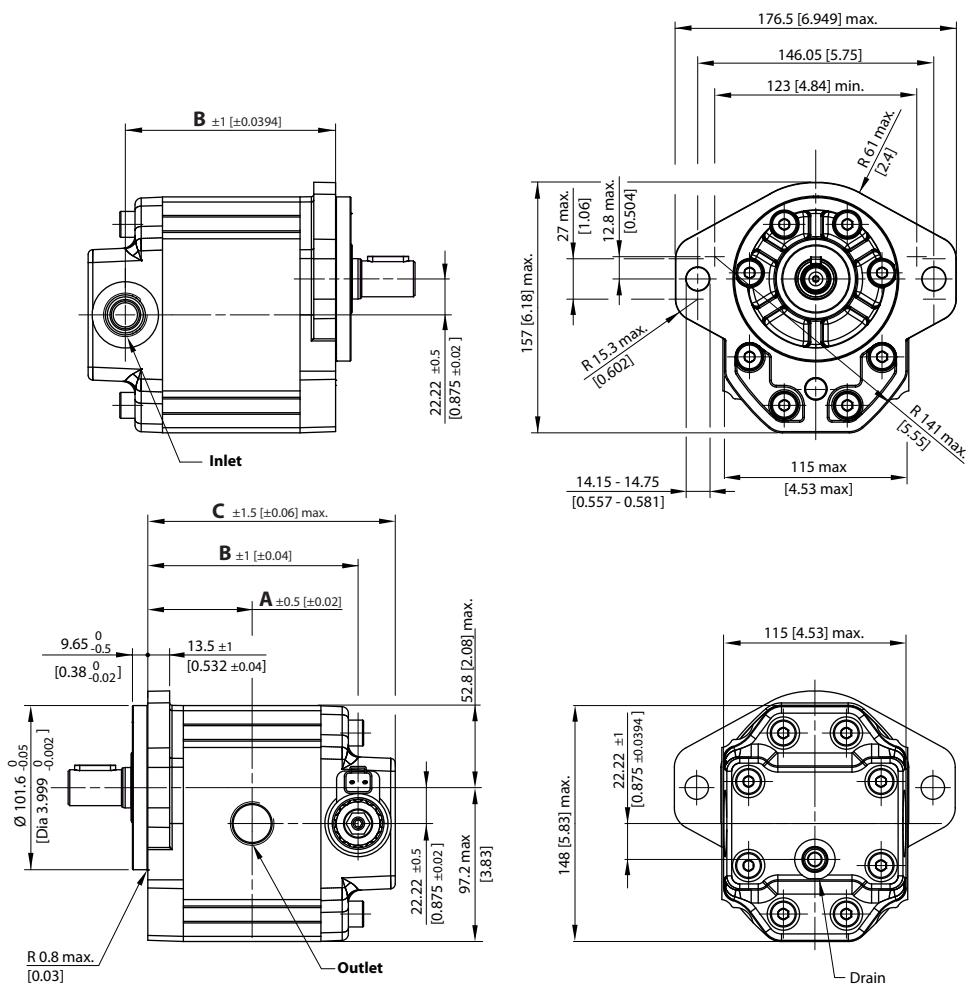

SGM3NC – 07GB dimensions

Dimension	Frame size				
	022	026	033	038	044
A	127.1 [5.04]	130.1 [5.12]	135.1 [5.32]	138.6 [5.46]	143.1 [5.63]
B	150.1 [5.91]	153.1 [6.03]	158.1 [6.22]	161.6 [6.36]	166.1 [6.54]
Inlet/Outlet	1-1/16-12UN-2B (SAE J1926/1, O-Ring boss); 19 [0.75] min. full thread				
Drain port	9/16-18UNF-2B (SAE J1926/1 O-Ring boss); 12.7 [0.5] min. full thread				

SGM3NC Fan Drive Motors (Group 3)

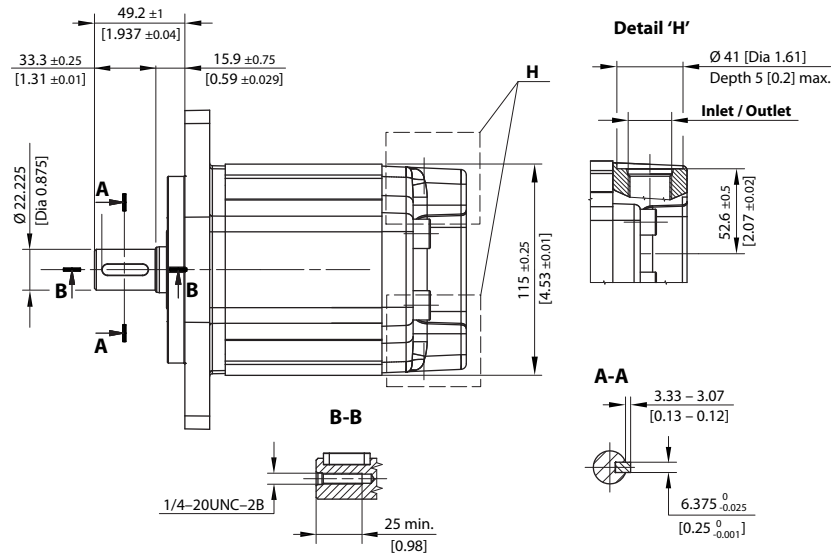

SGM3YN Fan Drive Motors (Group 3)

SGM3YN is Group 3 fan drive motor with inlet on rear cover and outlet on body. Integrated proportional relief valve, anti-cavitation check valve and axial drain line.

Displacement range from 22.1 cm³/rev up to 44.1 cm³/rev [from 1.34 in³/rev up to 2.69 in³/rev].

Configurations include European and SAE flanges; taper 1:8, taper 1:5 and parallel Ø15.875 mm [Dia 0.62 in] shafts.

Outrigger bearing available as SAE A flange with taper shaft 1:8 and European flange with taper shaft 1:5.

SGM3YN 07GB

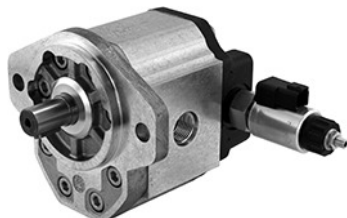
SGM3YN Technical Data

	Units	Frame size				
		022	026	033	038	044
Displacement	cm ³ /rev [in ³ /rev]	22.1 [1.34]	26.2 [1.60]	33.1 [2.02]	37.9 [2.31]	44.1 [2.69]
Peak pressure	bar [psi]	270 [3916]	270 [3916]	270 [3916]	270 [3916]	270 [3916]
Rated pressure		250 [3626]	250 [3626]	250 [3626]	250 [3626]	250 [3626]
Back pressure		150 [2176]	150 [2176]	150 [2176]	150 [2176]	150 [2176]
Maximum speed	min ⁻¹ [rpm]	2500	2500	2500	2500	2300
Minimum speed		800	800	800	800	800
Weight	kg [lb]	8.62 [19.0]	8.72 [19.23]	8.82 [19.45]	8.88 [19.58]	9.02 [19.89]
Moment of inertia of rotating components	x 10 ⁻⁶ kg·m ² [x 10 ⁻⁶ lbf·ft ²]	198 [4699]	216 [5126]	246 [5838]	267.2 [6341]	294.2 [6981]

SGM3YN Model Code Examples

Model code examples with maximum shaft torque

Flange/shaft	Model code example	Maximum shaft torque
07BC	SGM3YN/033LA07BCY6NNE6NNNN/XNNNN	300 N·m [2655 lb·in]
07GB	SGM3YN/022RA07GBY6NNE6NNNN/XNNNN	230 N·m [2036 lb·in]

[For further details on ordering, see *Model Code for Group 3 Fan Drive Motors* on page 47.](#)

SGM3YN Fan Drive Motors (Group 3)

SGM3YN Electric Proportional Relief Valve Data

Electric Proportional Relief Valve use Danfoss DT 04-2P connector with protection rate IP 69K per DIN 40050.

Relief valve – Standard

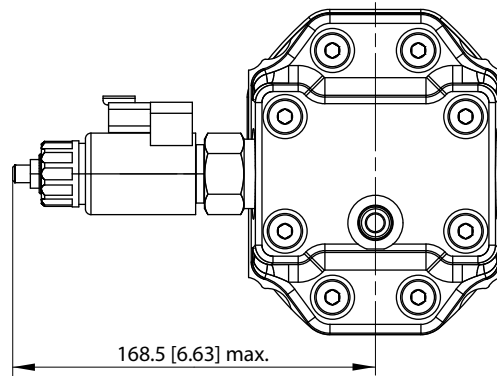

Relief valve with flat curve

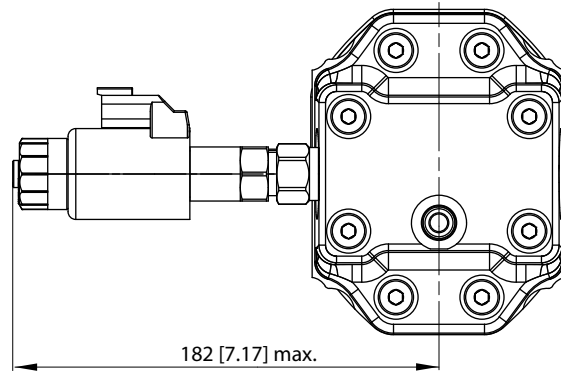

Description	Standard	Flat Curve
PWM frequency range	100 to 200 Hz	100 to 250 Hz
Supply 0 to 1.1 A @ 12 V _{DC}	Coil resistance of 7.2 Ω @ 20 °C [68 °F]	Coil resistance of 6.4 Ω @ 20 °C [68 °F]
Supply 0 to 0.55 A @ 24 V _{DC}	Coil resistance of 28.8 Ω @ 20 °C [68 °F]	Coil resistance of 26.2 Ω @ 20 °C [68 °F]

SGM3YN Fan Drive Motors (Group 3)

SGM3YN 07BC Dimensions

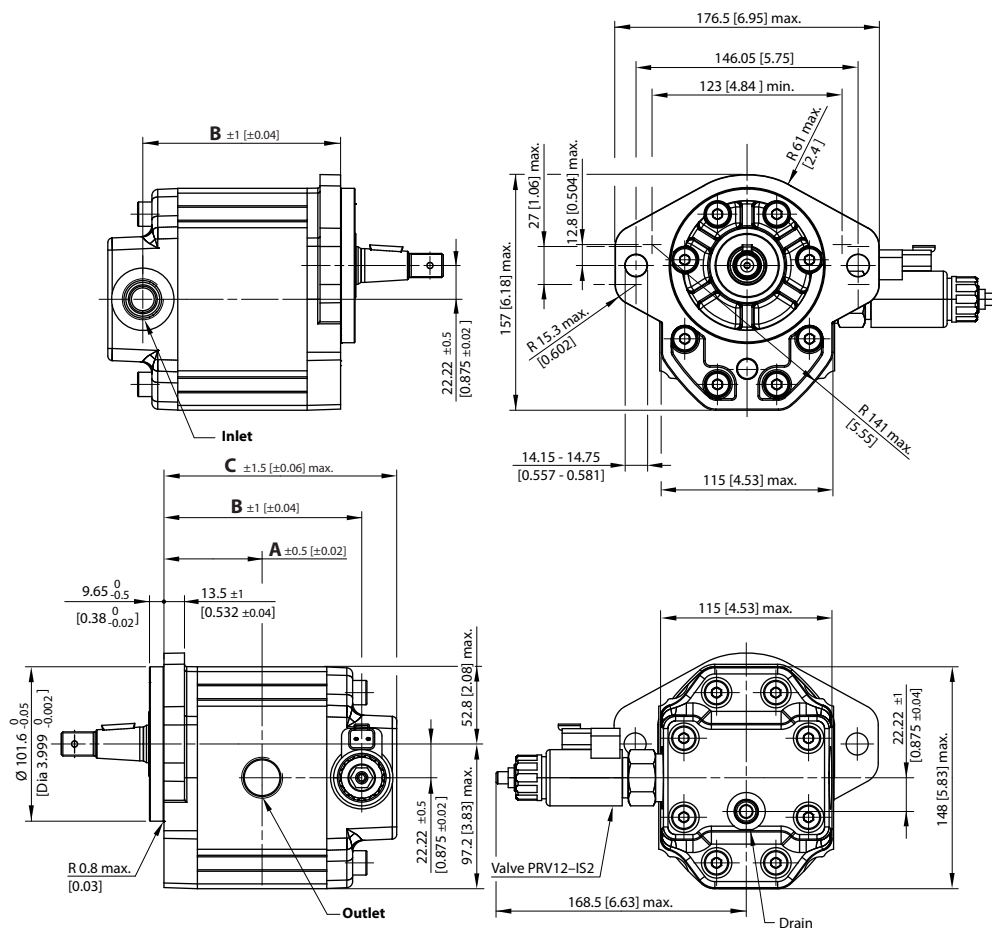

SGM3YN – 07GB dimensions

Dimension	Frame size				
	022	026	033	038	044
A	63 [2.48]	64.5 [2.54]	67 [2.64]	68.8 [2.71]	71 [2.8]
B	127.1 [5.04]	130.1 [5.12]	135.1 [5.32]	138.6 [5.46]	143.1 [5.63]
C	150.1 [5.91]	153.1 [6.03]	158.1 [6.22]	161.6 [6.36]	166.1 [6.54]
Inlet/Outlet	1-1/16-12UN-2B (SAE J1926/1, O-Ring boss); 19 [0.75] min. full thread				
Drain port	9/16-18UNF-2B (SAE J1926/1 O-Ring boss); 12.7 [0.5] min. full thread				

SGM3YN Fan Drive Motors (Group 3)

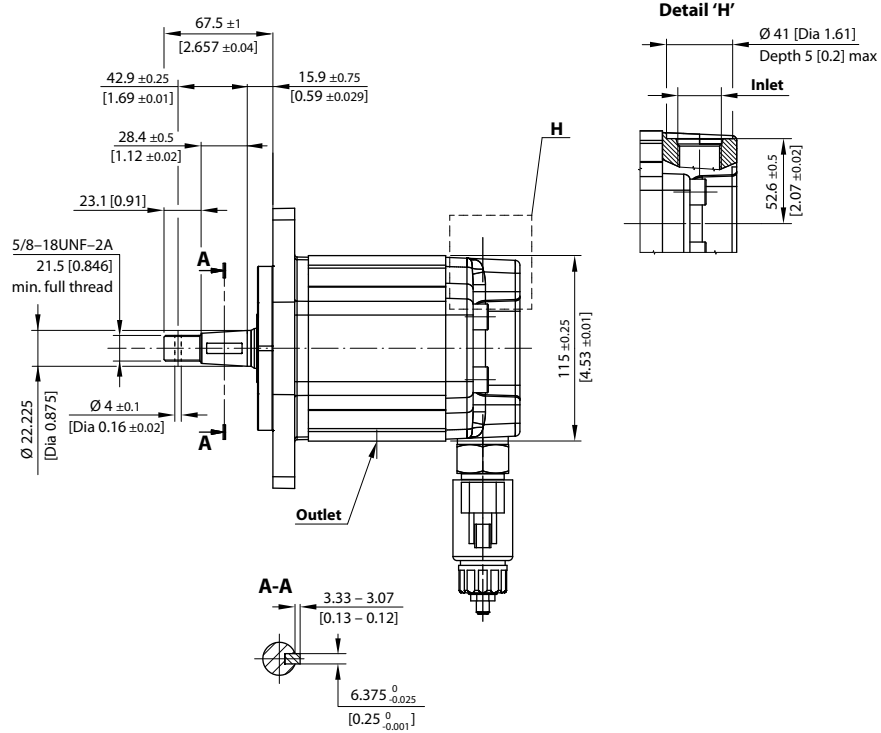

SGM3YN Fan Drive Motors (Group 3)

SGM3YN 07GB Dimensions

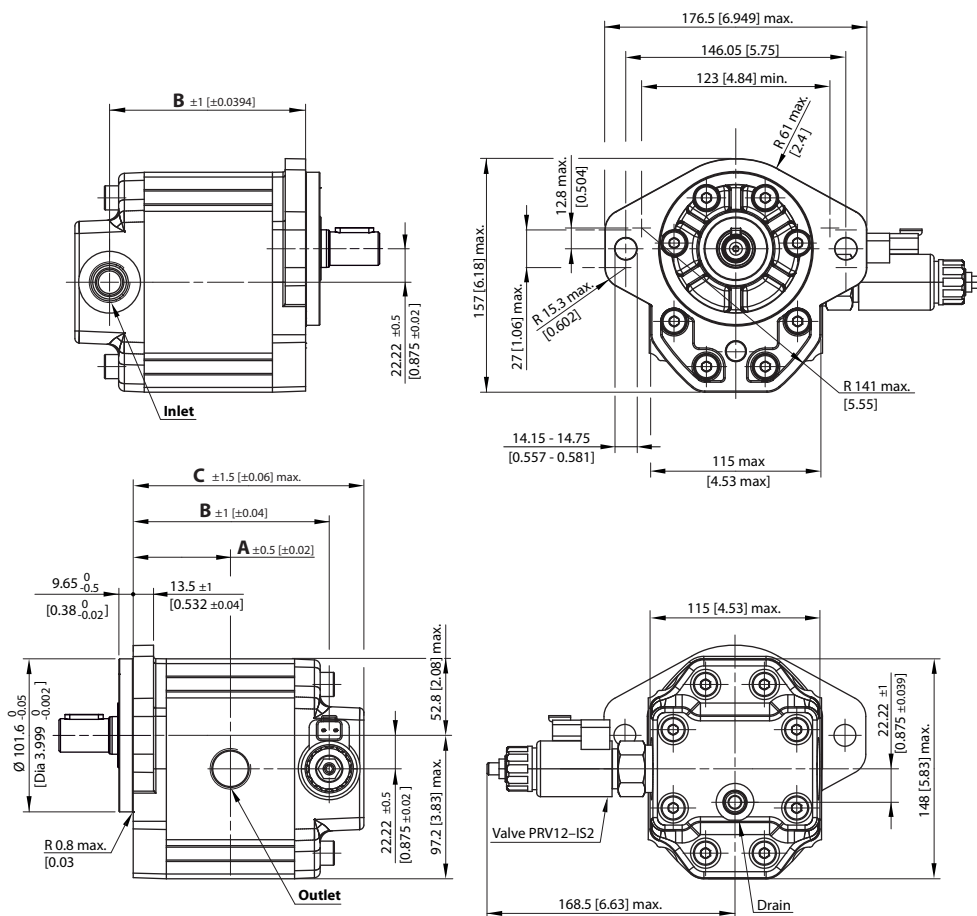

SGM3YN – 07GB dimensions

Dimension	Frame size				
	022	026	033	038	044
A	63 [2.48]	64.5 [2.54]	67 [2.64]	68.8 [2.71]	71 [2.8]
B	127.1 [5.04]	130.1 [5.12]	135.1 [5.32]	138.6 [5.46]	143.1 [5.63]
C	150.1 [5.91]	153.1 [6.03]	158.1 [6.22]	161.6 [6.36]	166.1 [6.54]
Inlet/Outlet	1-1/16-12UN-2B (SAE J1926/1, O-Ring boss); 19 [0.75] min. full thread				
Drain port	9/16-18UNF-2B (SAE J1926/1 O-Ring boss); 12.7 [0.5] min. full thread				

SGM3YN Fan Drive Motors (Group 3)

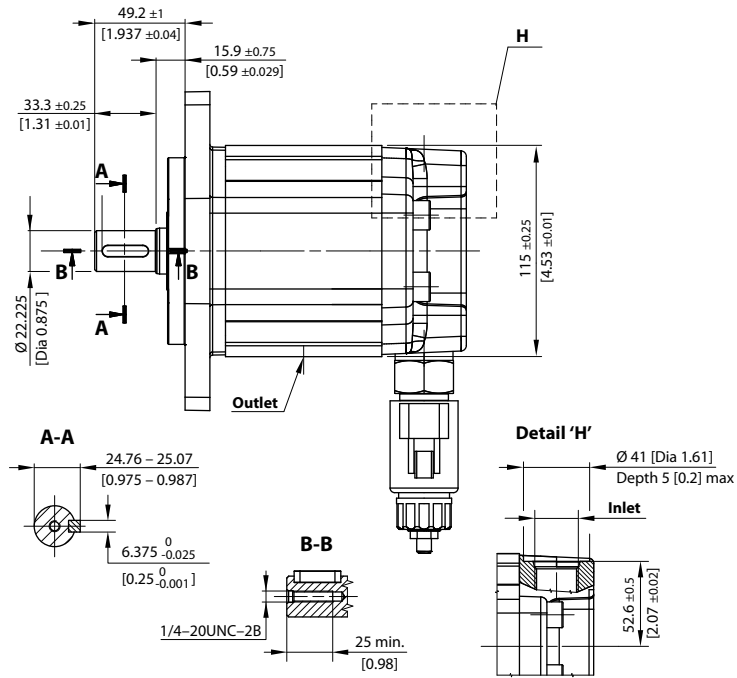

SGM3YN Fan Drive Motors (Group 3)

SGM3YN Outrigger Bearing Dimensions

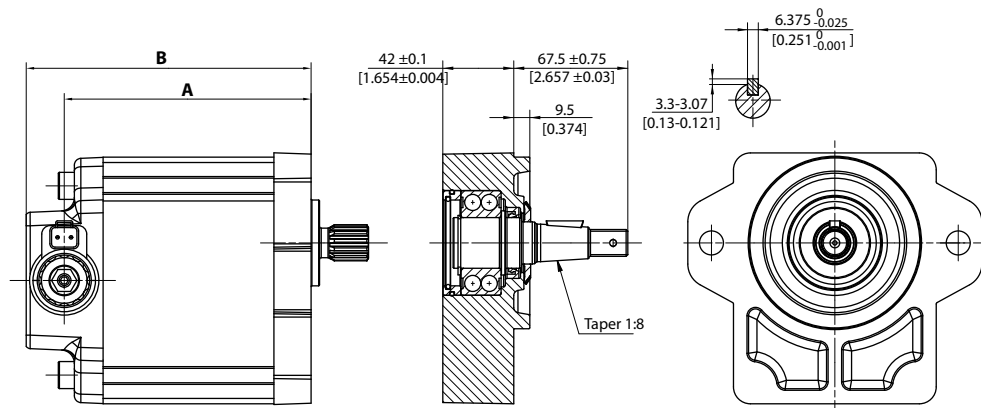

Dimension	Frame size				
	022	026	033	038	044
A	127.1 [5.04]	130.1 [5.12]	135.1 [5.32]	138.6 [5.46]	143.1 [5.63]
B	150.1 [5.91]	153.1 [6.03]	158.1 [6.22]	161.6 [6.36]	166.1 [6.54]

SGM3VC Fan Drive Motors (Group 3)

SGM3VC is Group 3 fan drive motor with integrated DCV valve for reverse function, anti-shock and proportional relief valve. Inlet/outlet and radial drain line are on cast iron rear cover.

Displacement range from 22.1 cm³/rev up to 44.1 cm³/rev [from 1.34 in³/rev up to 2.69 in³/rev].

Configurations include European and SAE flanges; taper 1:8, taper 1:5 and parallel Ø15.875 mm [Dia 0,62 in] shafts.

Outrigger bearing available as SAE A flange with taper shaft 1:8 and European flange with taper shaft 1:5.

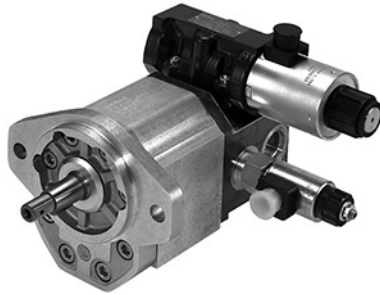
SGM3VC Technical Data

	Units	Frame size				
		022	026	033	038	044
Displacement	cm ³ /rev [in ³ /rev]	22.1 [1.34]	26.2 [1.60]	33.1 [2.02]	37.9 [2.31]	44.1 [2.69]
Peak pressure	bar [psi]	270 [3916]	270 [3916]	270 [3916]	270 [3916]	270 [3916]
Rated pressure		250 [3626]	250 [3626]	250 [3626]	250 [3626]	250 [3626]
Back pressure		150 [2176]	150 [2176]	150 [2176]	150 [2176]	150 [2176]
Maximum speed	min ⁻¹ [rpm]	2500	2500	2500	2500	2300
Minimum speed		800	800	800	800	800
Weight	kg [lb]	16.32 [35.8]	16.42 [36.2]	16.52 [36.42]	16.62 [36.64]	16.72 [36.86]
Moment of inertia of rotating components	x 10 ⁻⁶ kg·m ² [x 10 ⁻⁶ lbf·ft ²]	198 [4699]	216 [5126]	246 [5838]	267.2 [6341]	294.2 [6981]

SGM3VC Model Code Examples

Model code examples with maximum shaft torque

Flange/shaft	Model code example	Maximum shaft torque
07BC	SGM3VC/033LA07BCYENNE6NNNN/XNNNN	300 N·m [2655 lb·in]
07GB	SGM3VC/022RA07GBY6NNE6NNNN/XNNNN	230 N·m [2036 lb·in]

[For further details on ordering, see *Model Code for Group 3 Fan Drive Motors* on page 47.](#)

SGM3VC Fan Drive Motors (Group 3)

SGM3VC Electric Proportional Relief and D03 Directional Valves Data

Electric Proportional Relief Valve and Directional Valve (D03) use DEUTSCH DT 04-2P connector with protection rate IP 69K per DIN 40050.

Relief and directional valve – Standard

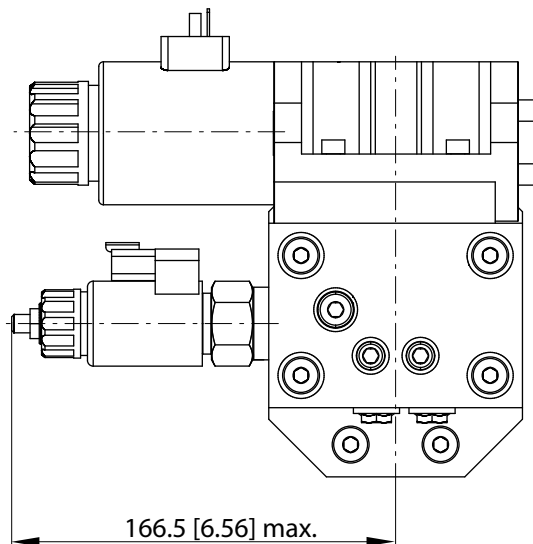

Relief valve and D03 directional valve with flat curve

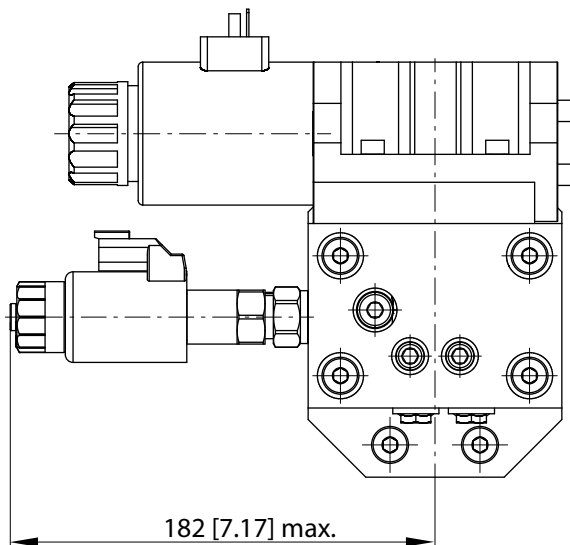

Description	Standard	Flat Curve
PWM frequency range	100 to 200 Hz	100 to 250 Hz
Supply 0 to 1.1 A @ 12 V _{DC}	Coil resistance of 7.2 Ω @ 20 °C [68 °F]	Coil resistance of 6.4 Ω @ 20 °C [68 °F]
Supply 0 to 0.55 A @ 24 V _{DC}	Coil resistance of 28.8 Ω @ 20 °C [68 °F]	Coil resistance of 26.2 Ω @ 20 °C [68 °F]

SGM3VC Fan Drive Motors (Group 3)

SGM3VC 07BC Dimensions

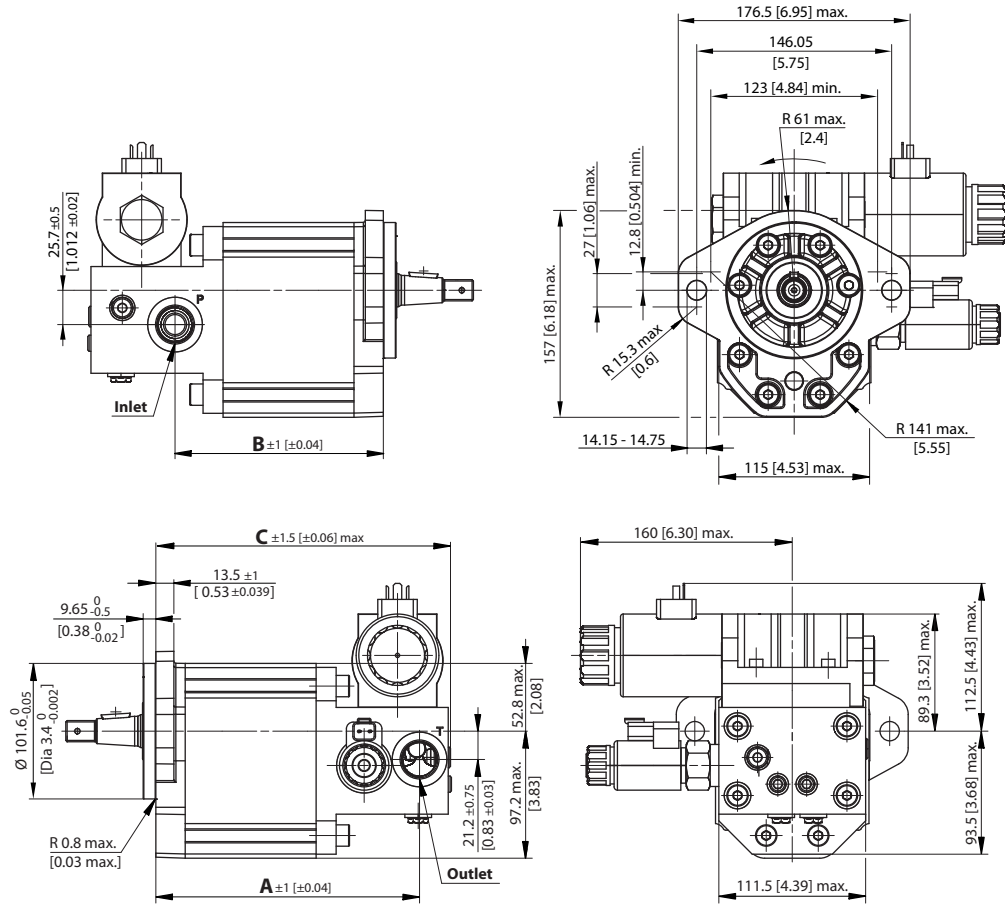

SGM3VC – 07BC dimensions

Dimension	Frame size				
	022	026	033	038	044
A	181.6 [7.15]	184.6 [7.27]	189.6 [7.46]	193.1 [7.62]	197.6 [7.78]
B	140.1 [5.52]	143.1 [5.63]	148.1 [5.83]	151.1 [5.95]	156.1 [6.15]
C	204.8 [8.06]	207.8 [8.18]	212.8 [8.38]	216.3 [8.52]	220.1 [8.67]
D	149.1 [5.87]	152.1 [5.99]	157.1 [6.19]	160.6 [6.32]	165.1 [6.50]
Inlet/Outlet	1-1/16-12UN-2B (SAE J1926/1, O-Ring boss); 19 [0.75] min. full thread				
Drain port	9/16-18UNF-2B (SAE J1926/1 O-Ring boss); 12.7 [0.5] min. full thread				

SGM3VC Fan Drive Motors (Group 3)

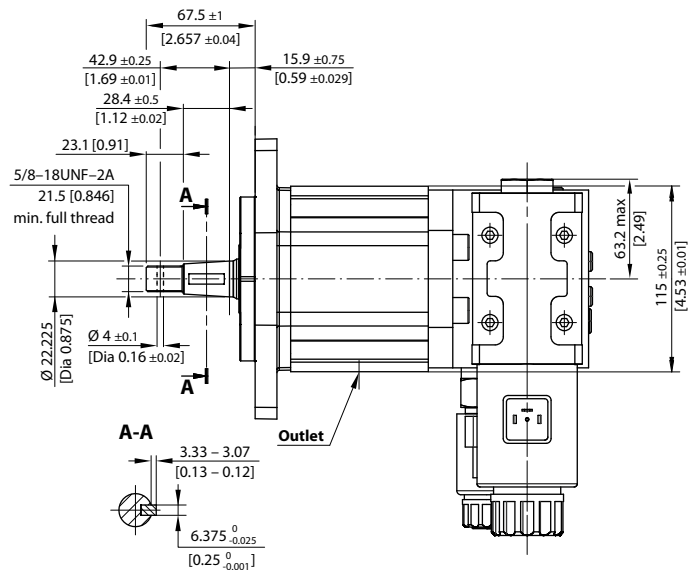

SGM3VC Fan Drive Motors (Group 3)

SGM3VC 07GB Dimensions

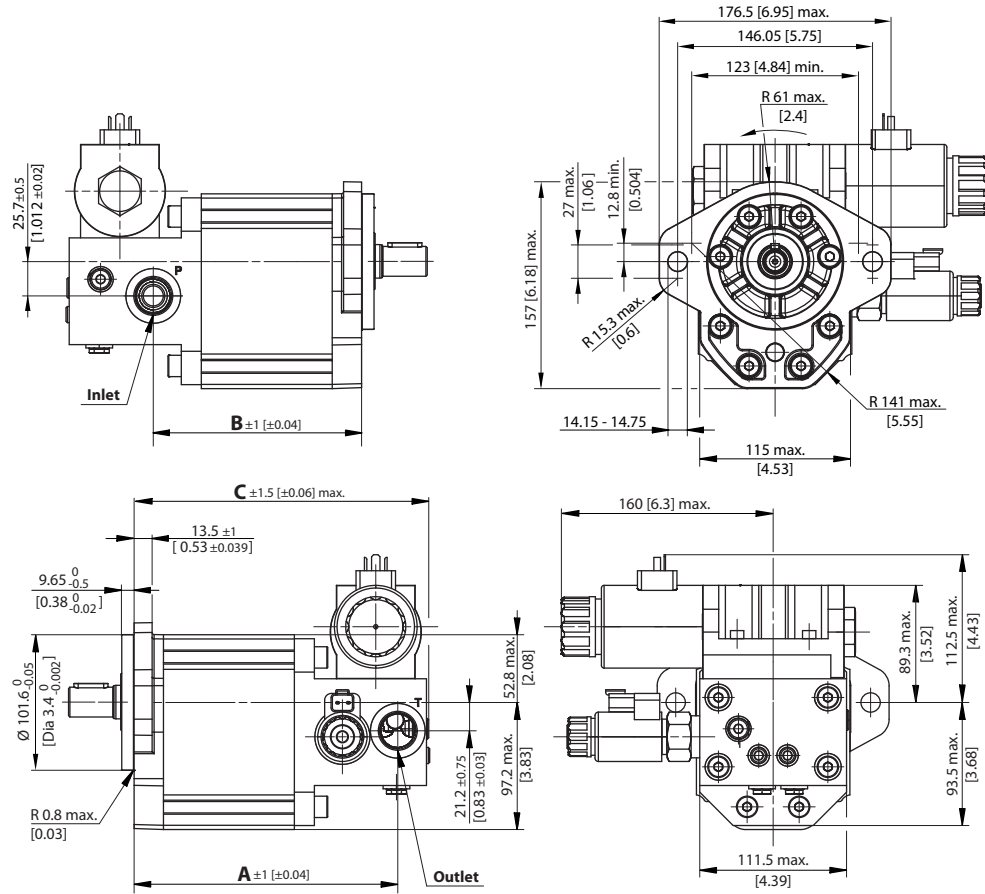

SGM3VC – 07GB dimensions

Dimension	Frame size				
	022	026	033	038	044
A	181.6 [7.15]	184.6 [7.27]	189.6 [7.46]	193.1 [7.62]	197.6 [7.78]
B	140.1 [5.52]	143.1 [5.63]	148.1 [5.83]	151.1 [5.95]	156.1 [6.15]
C	204.8 [8.06]	207.8 [8.18]	212.8 [8.38]	216.3 [8.52]	220.1 [8.67]
D	149.1 [5.87]	152.1 [5.99]	157.1 [6.19]	160.6 [6.32]	165.1 [6.50]
Inlet/Outlet	1-1/16-12UN-2B (SAE J1926/1, O-Ring boss); 19 [0.75] min. full thread				
Drain port	9/16-18UNF-2B (SAE J1926/1 O-Ring boss); 12.7 [0.5] min. full thread				

SGM3VC Fan Drive Motors (Group 3)

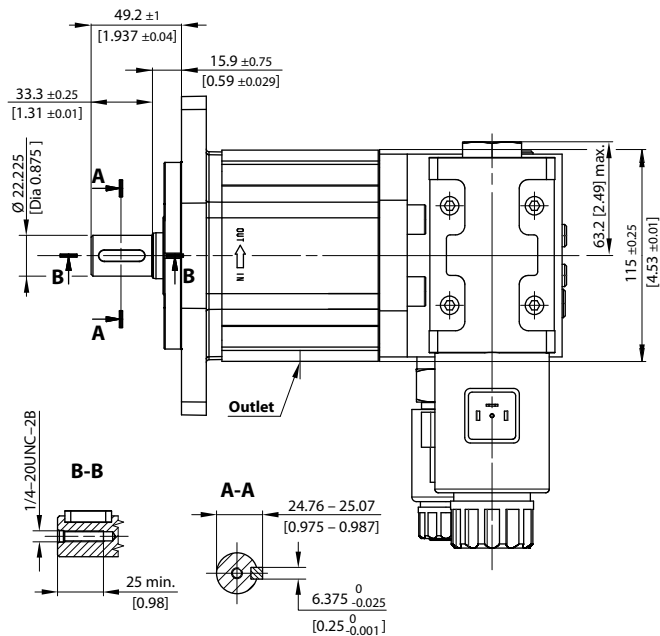

SGM3VC Fan Drive Motors (Group 3)

SGM3VC Outrigger Bearing Dimensions

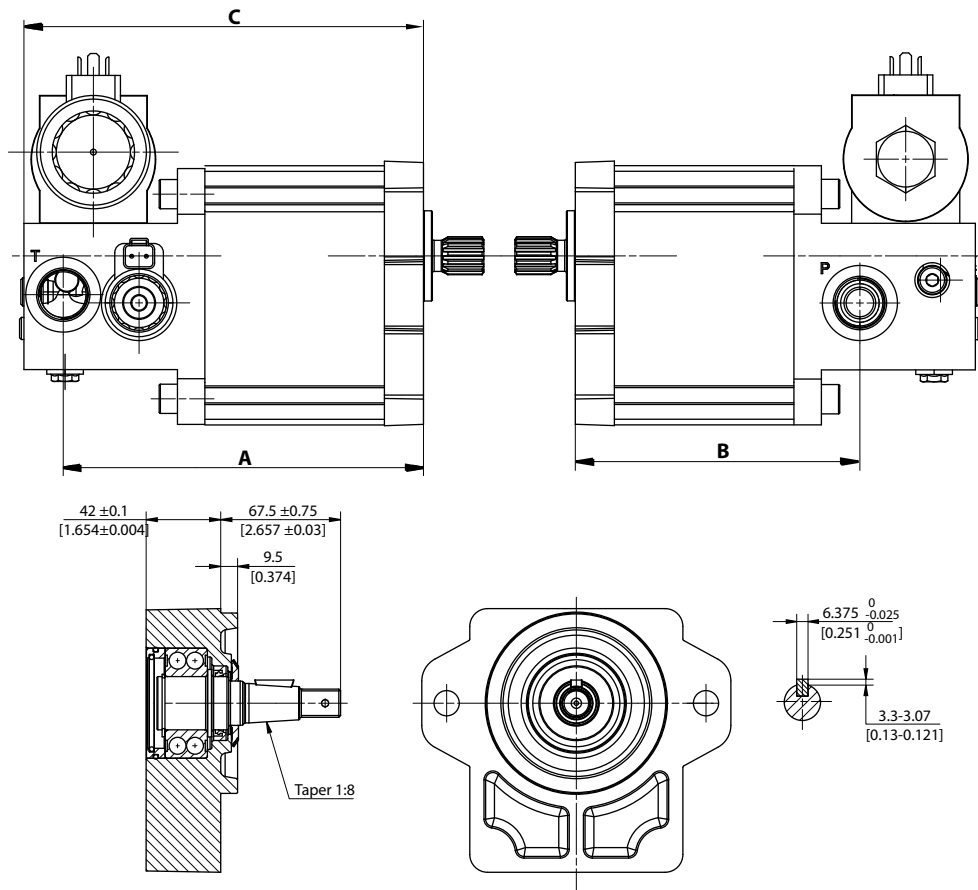

Dimension	Frame size				
	022	026	033	038	044
A (inlet)	181.6 [7.15]	184.6 [7.27]	189.6 [7.46]	193.1 [7.60]	197.6 [7.78]
B (outlet)	140.1 [5.52]	143.1 [5.63]	148.1 [5.83]	151.1 [5.95]	156.1 [6.15]
C (overall)	204.8 [8.06]	207.8 [8.18]	212.8 [8.38]	216.3 [8.52]	220.1 [8.67]

Products we offer:

- Cartridge valves
- DCV directional control valves
- Electric converters
- Electric machines
- Electric motors
- Gear motors
- Gear pumps
- Hydraulic integrated circuits (HICs)
- Hydrostatic motors
- Hydrostatic pumps
- Orbital motors
- PLUS+1® controllers
- PLUS+1® displays
- PLUS+1® joysticks and pedals
- PLUS+1® operator interfaces
- PLUS+1® sensors
- PLUS+1® software
- PLUS+1® software services, support and training
- Position controls and sensors
- PVG proportional valves
- Steering components and systems
- Telematics

Danfoss Power Solutions is a global manufacturer and supplier of high-quality hydraulic and electric components. We specialize in providing state-of-the-art technology and solutions that excel in the harsh operating conditions of the mobile off-highway market as well as the marine sector. Building on our extensive applications expertise, we work closely with you to ensure exceptional performance for a broad range of applications. We help you and other customers around the world speed up system development, reduce costs and bring vehicles and vessels to market faster.

Danfoss Power Solutions – your strongest partner in mobile hydraulics and mobile electrification.

Go to www.danfoss.com for further product information.

We offer you expert worldwide support for ensuring the best possible solutions for outstanding performance. And with an extensive network of Global Service Partners, we also provide you with comprehensive global service for all of our components.

Local address:

Hydro-Gear

www.hydro-gear.com

Daikin-Sauer-Danfoss

www.daikin-sauer-danfoss.com

**Danfoss
Power Solutions (US) Company**
2800 East 13th Street
Ames, IA 50010, USA
Phone: +1 515 239 6000

**Danfoss
Power Solutions GmbH & Co. OHG**
Krokamp 35
D-24539 Neumünster, Germany
Phone: +49 4321 871 0

**Danfoss
Power Solutions ApS**
Nordborgvej 81
DK-6430 Nordborg, Denmark
Phone: +45 7488 2222

**Danfoss
Power Solutions Trading
(Shanghai) Co., Ltd.**
Building #22, No. 1000 Jin Hai Rd
Jin Qiao, Pudong New District
Shanghai, China 201206
Phone: +86 21 2080 6201

Danfoss can accept no responsibility for possible errors in catalogues, brochures and other printed material. Danfoss reserves the right to alter its products without notice. This also applies to products already on order provided that such alterations can be made without subsequent changes being necessary in specifications already agreed. All trademarks in this material are property of the respective companies. Danfoss and the Danfoss logotype are trademarks of Danfoss A/S. All rights reserved.