

Data sheet

Manual Presetting Valves LENO™ MSV-D

Description

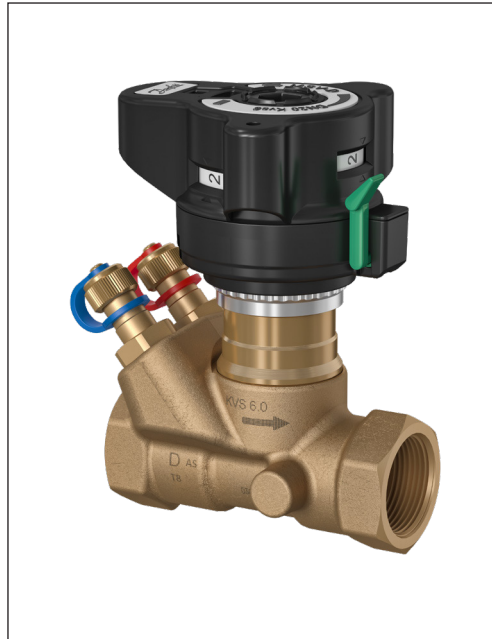

LENO MSV-D is a new generation of manual valves for balancing flow in heating and cooling systems.

LENO™ MSV-D is a combined presetting and shut off valve with a range of unique features:

- Removable hand wheel for easy mounting.
- Numeric presetting scale, visible from more angles.
- Easy locking of presetting.
- Built-in measuring nipples for 3mm needles.
- Open-close with Allen key in emergency.
- Open-closed colour indicator.

Dynamic balancing valves are the preferred option for hydronic balancing in constant and variable flow systems. If manual balancing valves are used for hydronic balancing they are better suited for constant flow systems. Manual balancing valves can be used in both constant and variable flow systems for flow verification, shut off function for service and repair. The valve may be mounted in flow or return.

Danfoss PFM 100/1000 are Danfoss recommended measuring devices.

Application

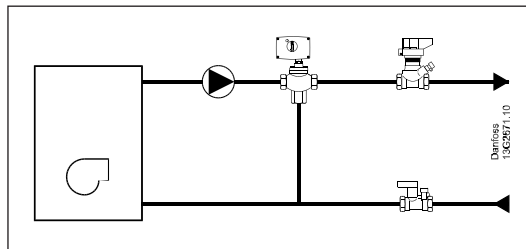

Boiler, flat station or heat pump.

- For balancing.
- Shut-off function for service/repair.

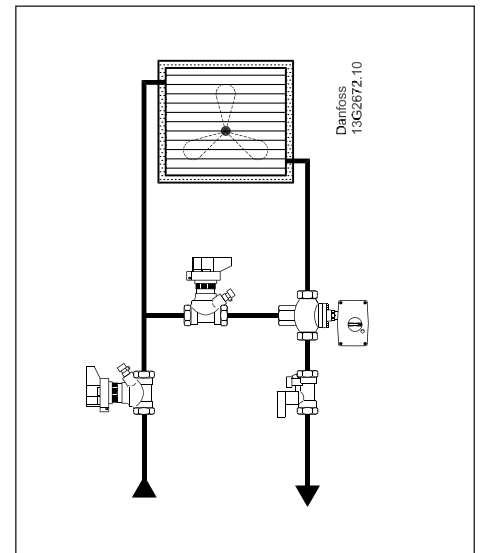

Air handling unit

- For constant flow.
- For balancing.
- Shut-off function for service/ repair.

Application (continuous)

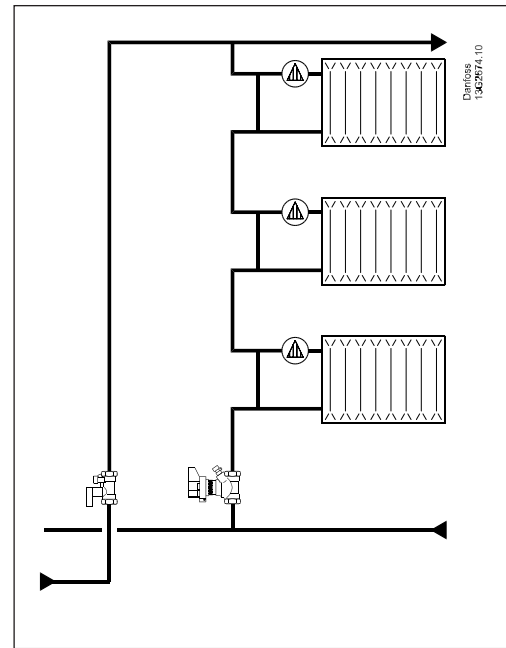
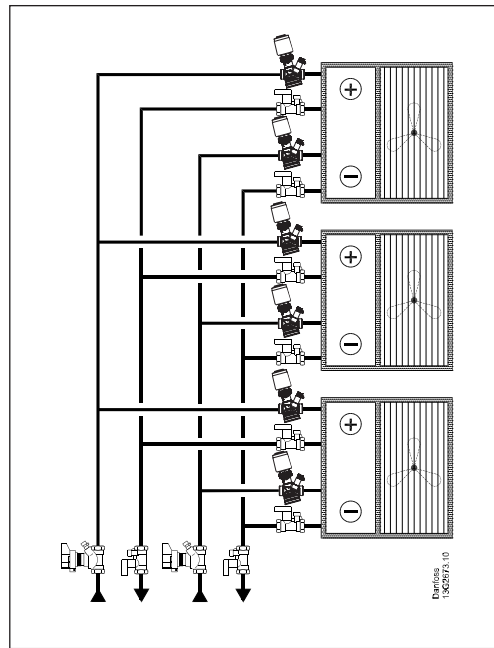

Fan coils

- For flow indication.
- Shut-off function for service/repair.

1-pipe system

- For balancing.
- Shut-off function for service/repair.

Ordering

LENO™ MSV-D valve with internal thread

Type	Material	Size	k_{vs} (m ³ /h)	Connections (ISO 228/2)	Code No.
	CW617N	DN 15 LF	2.5	G ½	003Z7000
		DN 15	3.0	G ½	003Z7001
		DN 20	6.0	G ¾	003Z7002
		DN 25	9.5	G 1	003Z7003
		DN 32	18	G 1¼	003Z7004
		DN 40	26	G 1½	003Z7005
DN 50	40	G 2	003Z7006		

Accessories

Type	Code No.
Operating handle	003Z4652
Flow measuring instrument PFM 100 (10 bar)	003L8260
Flow measuring instrument PFM 1000 (10 bar)	003Z8260
Flow measuring instrument PFM 1000 (20 bar)	003Z8261
Identification tag & strips, 10 pcs.	003Z4660

Accessories - Fittings

Type	Comments	to pipe	to valve	Code No.
	Tailpiece threaded (1 pcs.)	R ½	DN 15	003Z0232
		R ¾	DN 20	003Z0233
		R 1	DN 25	003Z0234
		R 1 ¼	DN 32	003Z0235
		R 1 ½	DN 40	003Z0273
		R 2	DN 50 (2 ¼")	003Z0274

Design

- 1. Valve body
- 2. Ball
- 3. Ball seat
- 4. Support screw
- 5. Throttle bush
- 6. Spindle head
- 7. Spindle
- 8. Shut off bush
- 9. Spring
- 10. Rotation lock
- 11. Top
- 12. Measuring nipple
- 13. Handle
- 14. Gasket for support screw

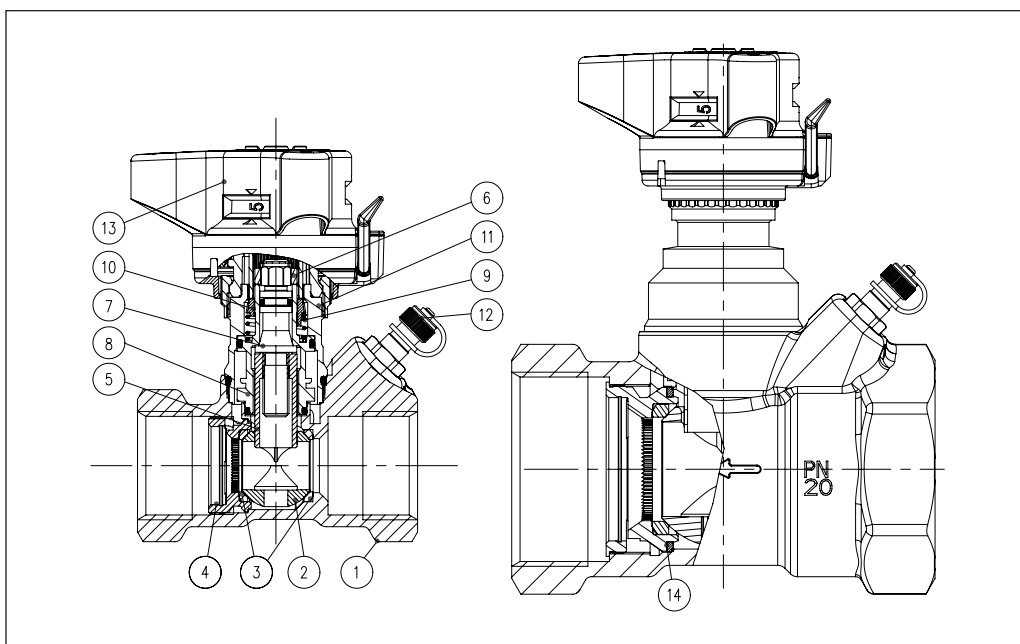

Technical Data

Materials and parts in contact with water

Valve body	Brass - CW617N
O-rings	EPDM
Ball	Brass/chromium plated
Ball sealing	Teflon

Max. static working pressure	20 bar
Static test pressure	30 bar
Max. differential pressure across valve	2.5 bar (250 kPa)
Max. flow temperature	120 °C
Min. temperature	-20 °C
Cooling liquids	Ethylene glycol / propylene glycol and HYCOOL (max. 30 %)

Fitting

Before fitting the valve the installer must ensure that the pipe system is clean and:

- 1. the valve can be turned 360 degrees (if threaded pipe is used).
- 2. the valve is fitted according to the flow direction arrow.

Removal of the handle

- 1. Set the handle at 0/0.
- 2. Release the setting lock (green).
- 3. Unscrew the union nut.

Calibration of the handle

Before refitting, ensure that the handle setting is 0/0.

Bi-directional functionality

If necessary (due to space constraints or any other reason), the MSV-D valve can be installed in the reversed orientation. The design of the valve means that kv of the valve remains the same in both orientation. For additional explanation of bi-directional functionality please use the link below or scan the QR code on the box label.

DN	R1/R2 (mm)
15	92/57
20	95/60
25	98/63
32	121/86
40	125/90
50	129/94

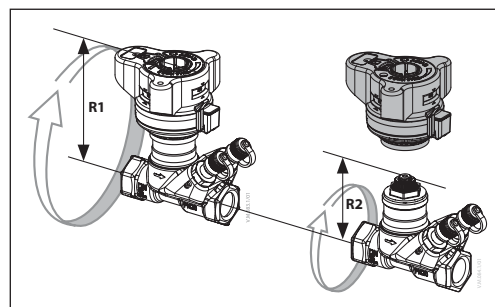

Shut-Off

In order to shut-off the valve the handle must be pressed down.

The shut-off function features a ball valve, which only requires a 90 degree turn to shut the valve completely.

An indicator window shows the actual setting:

- red = closed
- white = open

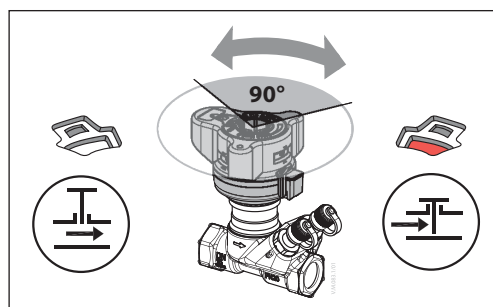

Setting and Locking

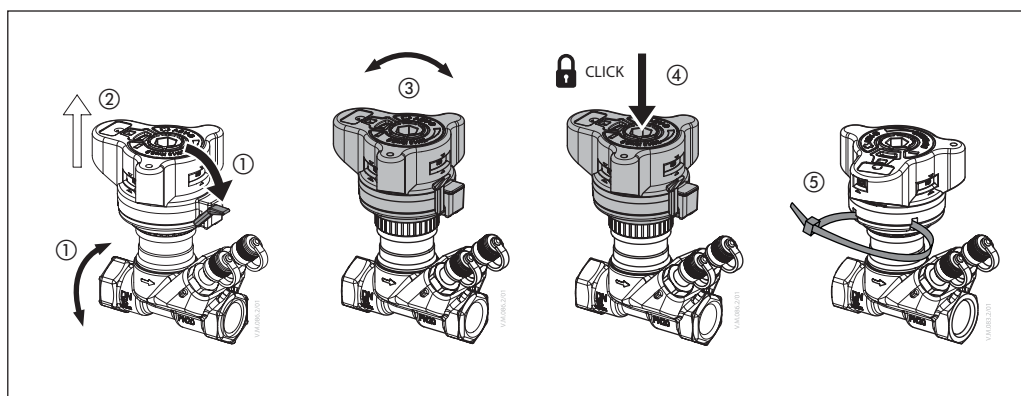

The valve has a built-in presetting feature for accurate flow ratings.

Setting the required flow is made in 5 steps:

1. Release the lock using the green lever or a 3 mm Allen key.

2. The handle pops up automatically.
3. The calculated value can now be set.
4. The setting is locked when the handle is pressed to click.
5. Seal - the setting can be protected by using a strip as shown.

Bi-directional functionality

Due to the valve's design it can be installed in the system so that the medium flows through the valve in same direction as is marked on the valve body (Flow arrow), or it can be installed in the system in the opposite direction, so that medium flows through the valve in the opposite direction to the marking on the valve body. The valve k_v values will remain unchanged, regardless of valve orientation.



Please, scan QR code or click on link to see animation:
<https://youtu.be/4zLTNO-jc4Y>

Measuring

The flow through the LENO™ MSV-D valve can be measured using Danfoss PFM 100/1000 or other brands of measuring instruments. The LENO™ MSV-D valve is supplied with two measuring test ports for 3 mm needles.

Procedure for flow measuring:

1. Select flow measuring
2. Select valve brand
3. Select valve type and dimension
4. Enter presetting
5. Connect valve and instrument
6. Calibrate static pressure
7. Measure the flow

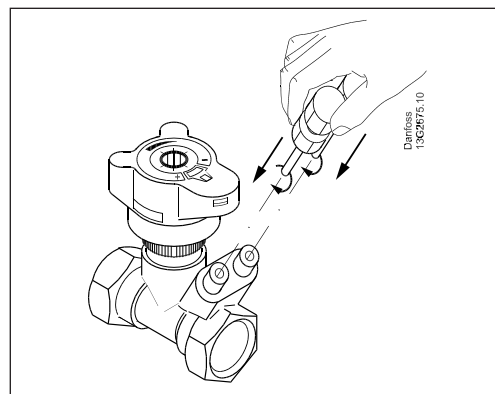

Measuring Accuracy

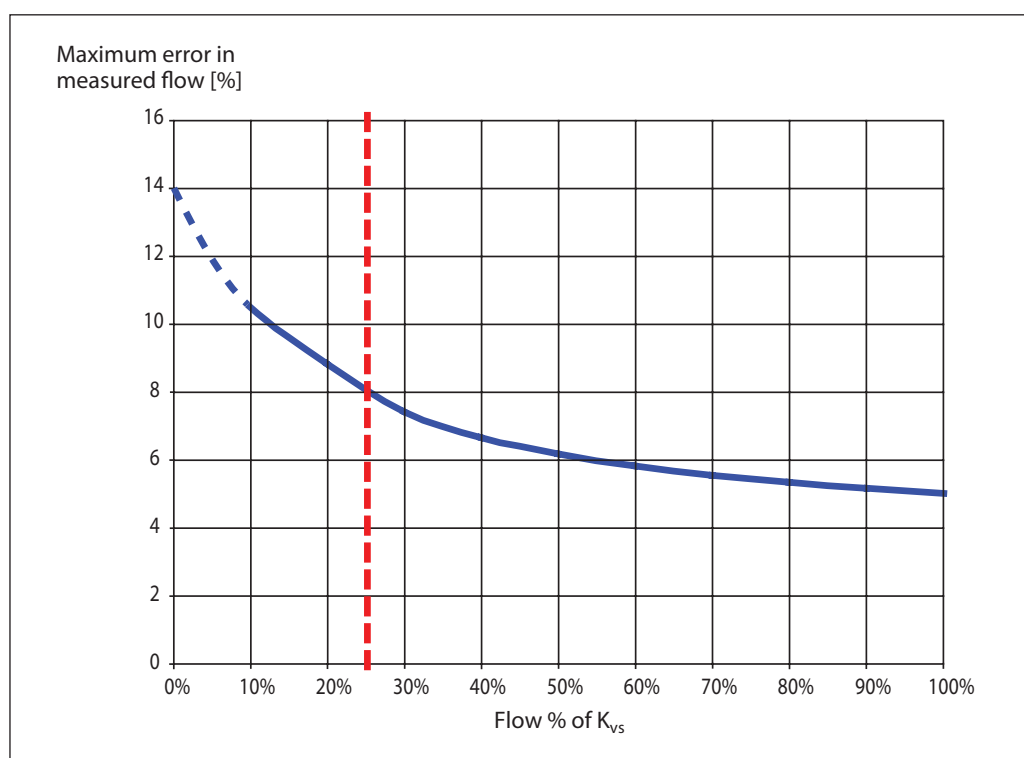

The red line indicates 25% of max. flow.

According to BS7350:1990 flow rates must be within following values:

- ± 18 % at 25 % open position
- ± 10 % at fully open position

LENO™ MSV-D is very accurate, due to the separate functions for presetting and shut-off.

K_v-Signal

K_v-signal values are used for non-Danfoss measuring instruments. Danfoss PFM1000 have all data in memory, and the instruments are using this formula:

$$P_{val} = P_{sig} \left(1 + 4 \cdot \frac{k_{v-sig}}{k_{v-val}} \right)^2$$

Δp across the measuring nipples (k_{v-sig}) and Δp across the valve (k_{v-val}) is not the same due to turbulence influence for pressure measuring.

K_v-Signal Values

Setting	DN 15LF	DN 15	DN 20	DN 25	DN 32	DN 40	DN 50
0.0	0.07	0.10	0.12	0.34	0.51	1.05	1.75
0.1	0.08	0.11	0.16	0.44	0.73	1.20	2.01
0.2	0.09	0.12	0.20	0.53	0.92	1.36	2.25
0.3	0.11	0.13	0.26	0.61	1.10	1.55	2.47
0.4	0.12	0.14	0.32	0.67	1.26	1.74	2.69
0.5	0.13	0.16	0.38	0.73	1.43	1.95	2.91
0.6	0.15	0.19	0.45	0.79	1.60	2.17	3.12
0.7	0.16	0.21	0.53	0.84	1.78	2.40	3.35
0.8	0.17	0.24	0.60	0.90	1.97	2.64	3.58
0.9	0.19	0.26	0.67	0.95	2.18	2.88	3.82
1.0	0.20	0.29	0.74	1.01	2.39	3.13	4.07
1.1	0.21	0.32	0.82	1.08	2.62	3.39	4.33
1.2	0.23	0.34	0.89	1.14	2.87	3.64	4.60
1.3	0.25	0.37	0.96	1.22	3.12	3.90	4.89
1.4	0.27	0.40	1.03	1.29	3.38	4.16	5.18
1.5	0.30	0.44	1.09	1.37	3.64	4.43	5.49
1.6	0.32	0.47	1.16	1.46	3.92	4.69	5.80
1.7	0.35	0.51	1.23	1.55	4.18	4.96	6.13
1.8	0.37	0.54	1.30	1.65	4.48	5.24	6.46
1.9	0.40	0.58	1.38	1.75	4.76	5.51	6.80
2.0	0.43	0.61	1.45	1.85	5.05	5.80	7.14
2.1	0.46	0.65	1.53	1.96	5.35	6.08	7.49
2.2	0.49	0.69	1.61	2.07	5.65	6.38	7.84
2.3	0.52	0.73	1.69	2.18	5.96	6.68	8.19
2.4	0.56	0.77	1.78	2.29	6.27	6.99	8.55
2.5	0.59	0.80	1.87	2.41	6.60	7.30	8.91
2.6	0.62	0.85	1.97	2.53	6.94	7.63	9.27
2.7	0.66	0.89	2.07	2.65	7.29	7.98	9.64
2.8	0.69	0.93	2.17	2.77	7.67	8.33	10.00
2.9	0.73	0.97	2.29	2.89	8.06	8.70	10.37
3.0	0.76	1.01	2.40	3.01	8.48	9.08	10.74
3.1	0.80	1.04	2.52	3.13	8.92	9.48	11.11
3.2	0.83	1.08	2.65	3.25	9.38	9.90	11.49
3.3	0.87	1.12	2.78	3.37	9.87	10.33	11.88
3.4	0.90	1.16	2.91	3.49	10.38	10.79	12.27
3.5	0.94	1.20	3.05	3.62	10.91	11.26	12.67
3.6	0.97	1.25	3.19	3.74	11.46	11.74	13.09
3.7	1.01	1.30	3.33	3.87	12.02	12.25	13.51
3.8	1.06	1.35	3.47	4.00	12.58	12.77	13.95
3.9	1.10	1.41	3.61	4.13	13.12	13.30	14.41
4.0	1.14	1.47	3.75	4.26	13.64	13.85	14.88
4.1	1.18	1.53	3.89	4.39	14.12	14.41	15.38
4.2	1.23	1.59	4.02	4.53	14.52	14.98	15.89
4.3	1.27	1.66	4.15	4.68	14.84	15.55	16.44
4.4	1.31	1.73	4.28	4.82	-	16.13	17.00
4.5	1.35	1.81	4.40	4.98	-	16.69	17.59
4.6	1.39	1.91	4.52	5.13	-	17.25	18.21
4.7	1.43	2.00	4.62	5.29	-	17.80	18.86
4.8	1.47	2.08	4.72	5.46	-	18.32	19.54
4.9	1.51	2.16	4.82	5.64	-	18.80	20.24
5.0	1.54	2.23	4.90	5.81	-	19.25	20.97
5.1	1.60	2.30	4.97	6.00	-	19.65	21.73
5.2	1.66	2.36	5.04	6.19	-	19.98	22.51
5.3	1.72	2.41	5.09	6.38	-	20.24	23.30
5.4	1.79	2.46	5.14	6.57	-	20.41	24.12
5.5	1.87	2.50	5.18	6.77	-	20.48	24.94
5.6	1.93	2.54	5.21	6.96	-	-	25.76
5.7	1.99	2.57	5.24	7.15	-	-	26.58
5.8	2.04	-	5.27	7.34	-	-	27.38
5.9	2.09	-	-	7.52	-	-	28.16
6.0	2.14	-	-	7.69	-	-	28.90
6.1	2.18	-	-	7.85	-	-	29.59
6.2	2.22	-	-	7.98	-	-	30.21
6.3	2.26	-	-	8.09	-	-	30.74
6.4	-	-	-	8.17	-	-	31.17
6.5	-	-	-	8.22	-	-	31.47
6.6	-	-	-	-	-	-	31.61

K_v-Signal

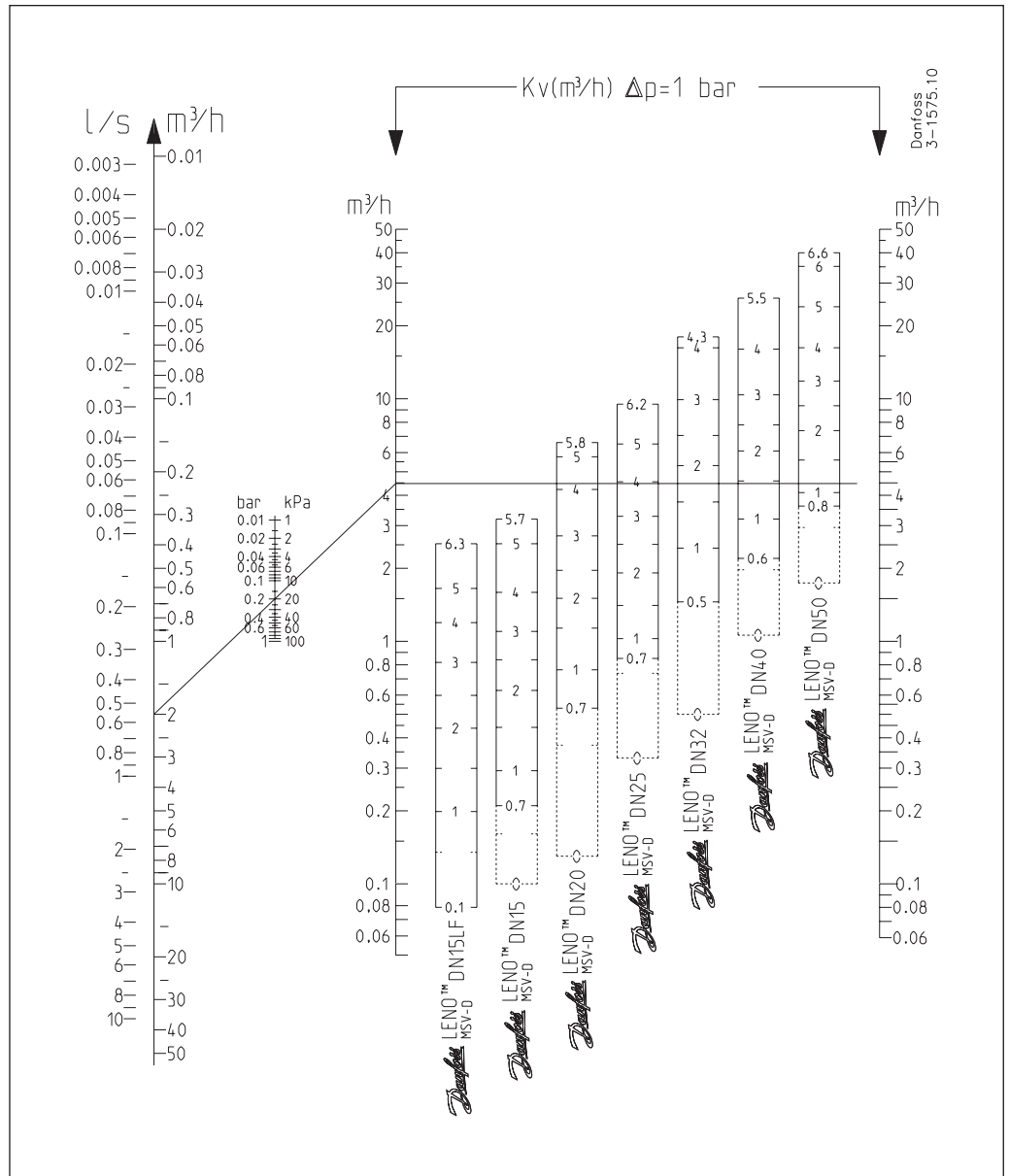

Correction Factors

Temp. °C	Correction factors, ethylene glycol / propylene glycol percentage (max. 30 %)						
	25	30	40	50	60	65	100
-40.0	¹⁾	¹⁾	¹⁾	¹⁾	0.89	0.88	¹⁾
-17.8	¹⁾	¹⁾	0.93	0.91	0.90	0.89	0.86
4.4	0.95	0.95	0.93	0.92	0.91	0.90	0.87
26.6	0.96	0.95	0.94	0.93	0.92	0.91	0.88
48.9	0.97	0.96	0.95	0.94	0.93	0.92	0.90
71.1	0.98	0.98	0.96	0.95	0.94	0.94	0.95
93.3	1.00	0.99	0.97	0.96	0.95	0.95	0.92
115.6	²⁾	²⁾	²⁾	²⁾	²⁾	²⁾	0.94

¹⁾ Below freezing point
²⁾ Above boiling point

Example: Flow needed = 30 m³/h
 Flow after correction:
 30 x 0.95 = 28 m³/h

Valve Size and Presetting

Example:

Given

Max. pipe flow Q = 2 m³/h
 $\Delta p_r = 15 \text{ kPa}$
 $\Delta p_a = 45 \text{ kPa}$
 $\Delta p_m = 10 \text{ kPa}$
 $\Delta p_i = \Delta p_a - \Delta p_r - \Delta p_m$
 $\Delta p_i = 45 - 15 - 10 = 20 \text{ kPa}$

Correct valve size and presetting is found in flow diagramme, page 7.

Q = 2.0 m³/h and $\Delta p_i = 20 \text{ kPa}$

On page 10 intersect guides and presetting is found to be 4.2 (DN 20 valve)

Setting can be also calculated from the formula:

$$k_v = \frac{Q[\text{m}^3/\text{h}]}{\sqrt{p_i[\text{bar}]}} = \frac{2.0}{\sqrt{0.2}} = 4.5 \text{ m}^3/\text{h}$$

which corresponds to presetting 4.2 as shown on pages 7 and 11.

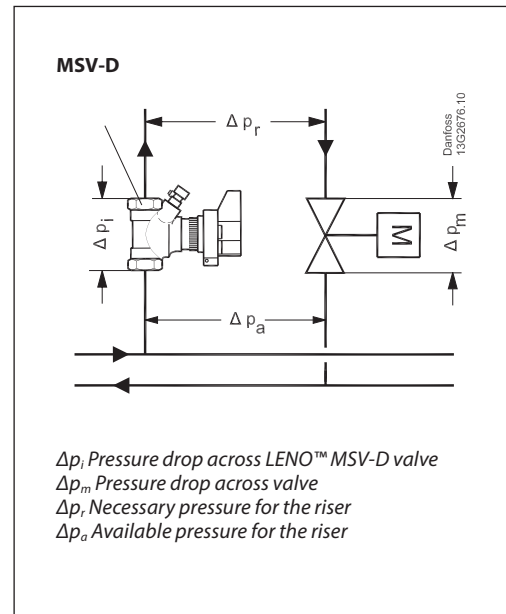

Flow Diagrammes, DN 15 LF

Setting	k_v -value
0.0	0.07
0.1	0.08
0.2	0.09
0.3	0.11
0.4	0.12
0.5	0.13
0.6	0.15
0.7	0.16
0.8	0.17
0.9	0.19
0.10	0.20
1.1	0.22
1.2	0.23
1.3	0.25
1.4	0.28
1.5	0.30
1.6	0.32
1.7	0.35
1.8	0.38
1.9	0.41
2.0	0.44
2.1	0.47
2.2	0.50
2.3	0.53
2.4	0.56
2.5	0.60
2.6	0.63
2.7	0.67
2.8	0.71
2.9	0.74
3.0	0.78
3.1	0.82
3.2	0.86
3.3	0.89
3.4	0.93
3.5	0.97
3.6	1.01
3.7	1.05
3.8	1.10
3.9	1.15
4.0	1.19
4.1	1.24
4.2	1.29
4.3	1.33
4.4	1.38
4.5	1.43
4.6	1.48
4.7	1.52
4.8	1.56
4.9	1.61
5.0	1.65
5.1	1.72
5.2	1.78
5.3	1.86
5.4	1.94
5.5	2.03
5.6	2.10
5.7	2.17
5.8	2.23
5.9	2.30
6.0	2.36
6.1	2.42
6.2	2.47
6.3	2.53

LENO™ MSV-D DN 15 LF

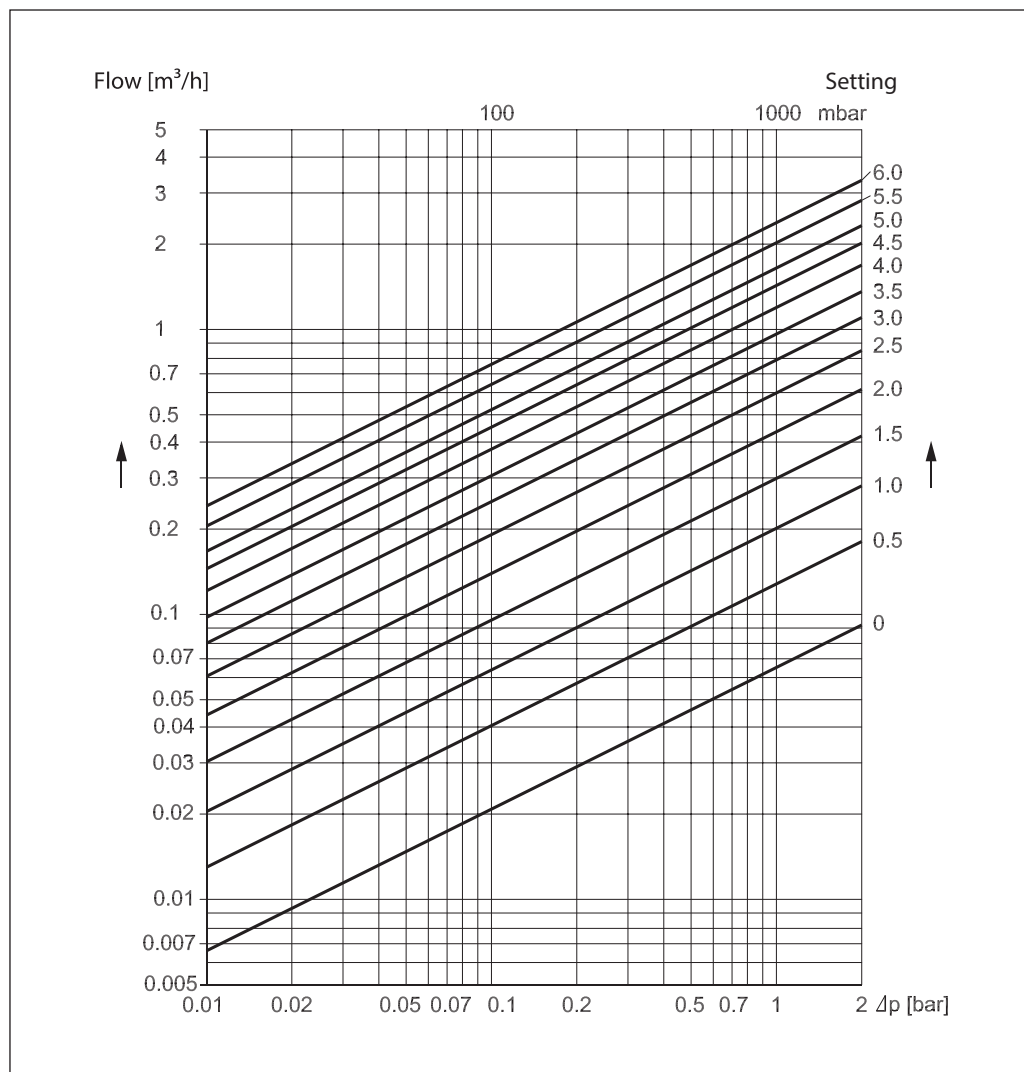

Flow characteristics

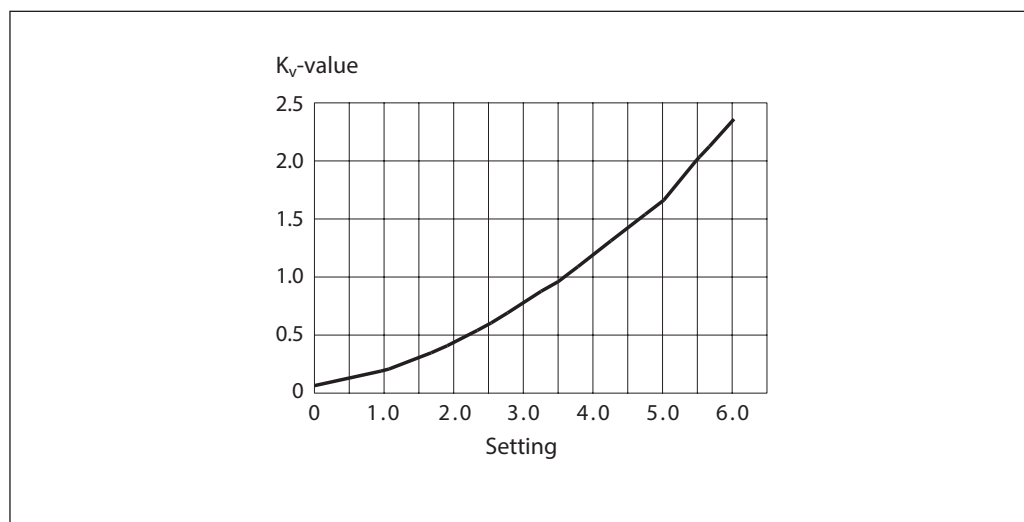

Flow Diagrammes, DN 15

Setting	k_v -value
0.0	0.11
0.1	0.12
0.2	0.13
0.3	0.14
0.4	0.16
0.5	0.19
0.6	0.20
0.7	0.21
0.8	0.24
0.9	0.27
1.0	0.29
1.1	0.32
1.2	0.35
1.3	0.38
1.4	0.41
1.5	0.44
1.6	0.48
1.7	0.51
1.8	0.55
1.9	0.59
2.0	0.63
2.1	0.67
2.2	0.71
2.3	0.75
2.4	0.80
2.5	0.84
2.6	0.88
2.7	0.93
2.8	0.97
2.9	1.02
3.0	1.06
3.1	1.10
3.2	1.14
3.3	1.19
3.4	1.23
3.5	1.28
3.6	1.34
3.7	1.40
3.8	1.46
3.9	1.52
4.0	1.59
4.1	1.66
4.2	1.74
4.3	1.82
4.4	1.91
4.5	2.00
4.6	2.12
4.7	2.23
4.8	2.33
4.9	2.43
5.0	2.53
5.1	2.61
5.2	2.70
5.3	2.77
5.4	2.84
5.5	2.90
5.6	2.95
5.7	3.00

LENO™ MSV-D DN 15

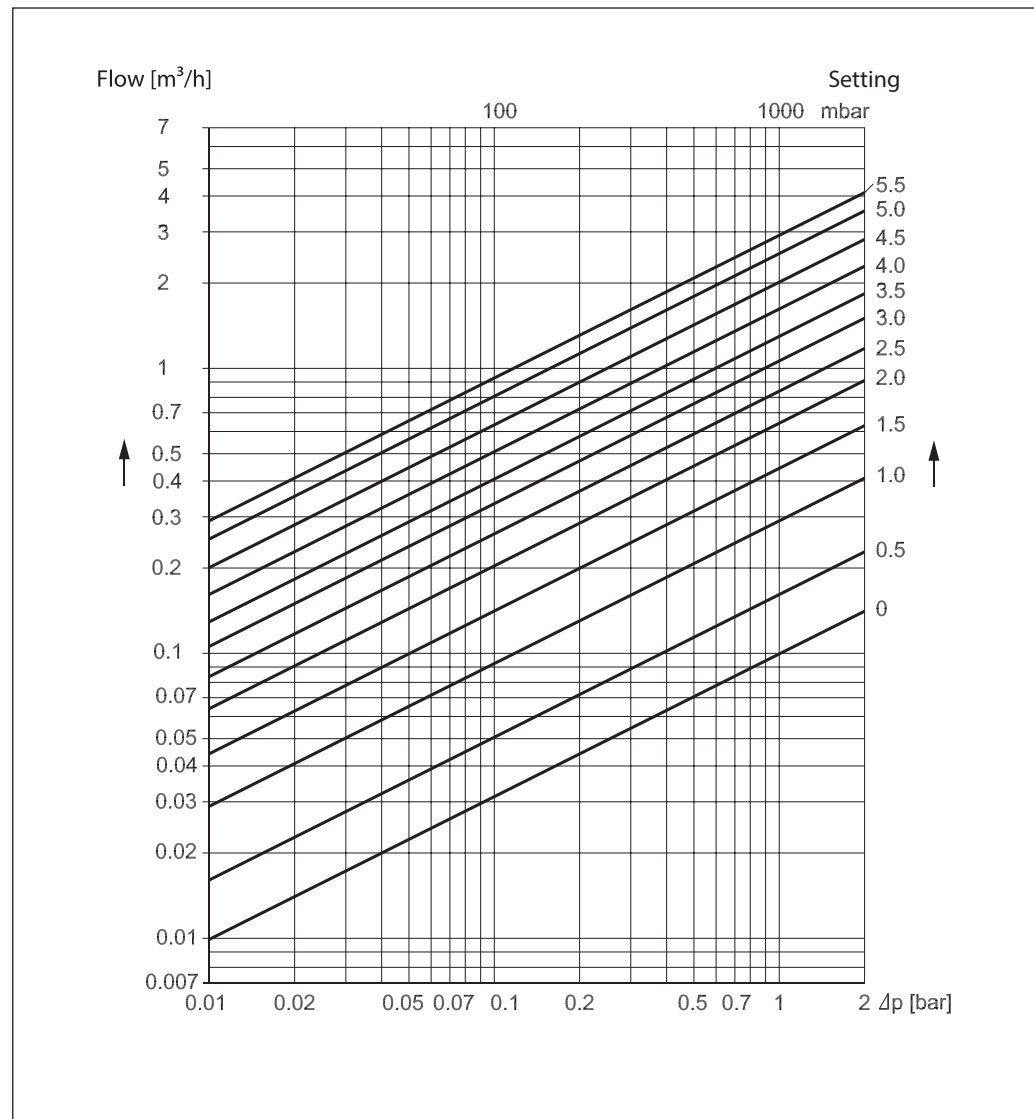

Flow characteristics

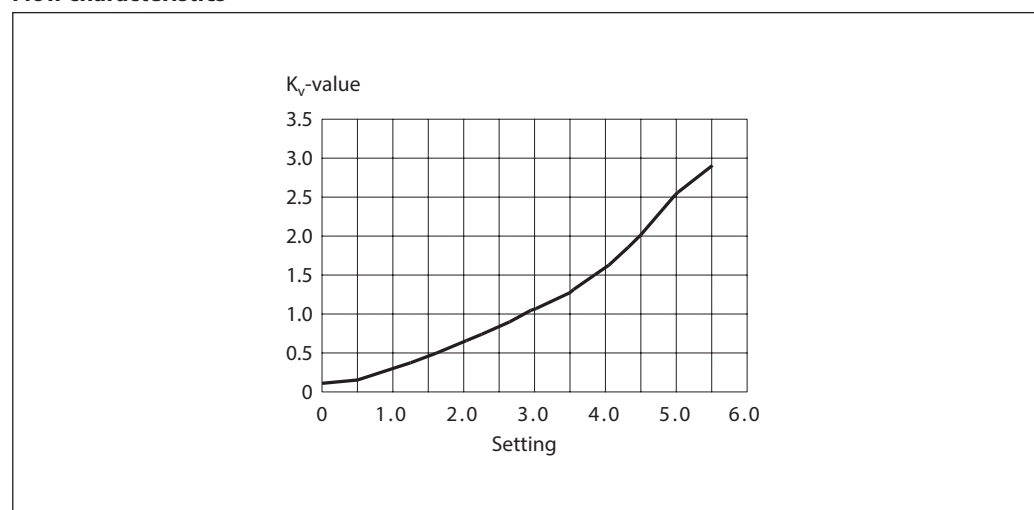

Flow Diagrammes, DN 20

Setting	k_v -value
0.0	0.13
0.1	0.15
0.2	0.19
0.3	0.24
0.4	0.30
0.5	0.37
0.6	0.45
0.7	0.53
0.8	0.61
0.9	0.68
0.10	0.76
1.1	0.84
1.2	0.92
1.3	0.99
1.4	1.06
1.5	1.13
1.6	1.21
1.7	1.28
1.8	1.35
1.9	1.43
2.0	1.50
2.1	1.59
2.2	1.67
2.3	1.76
2.4	1.86
2.5	1.96
2.6	2.07
2.7	2.19
2.8	2.31
2.9	2.44
3.0	2.58
3.1	2.72
3.2	2.87
3.3	3.03
3.4	3.19
3.5	3.36
3.6	3.53
3.7	3.70
3.8	3.87
3.9	4.05
4.0	4.23
4.1	4.40
4.2	4.58
4.3	4.75
4.4	4.91
4.5	5.07
4.6	5.22
4.7	5.37
4.8	5.51
4.9	5.64
5.0	5.77
5.1	5.88
5.2	5.99
5.3	6.09
5.4	6.19
5.5	6.29
5.6	6.39
5.7	6.49
5.8	6.60

LENO™ MSV-D DN 20

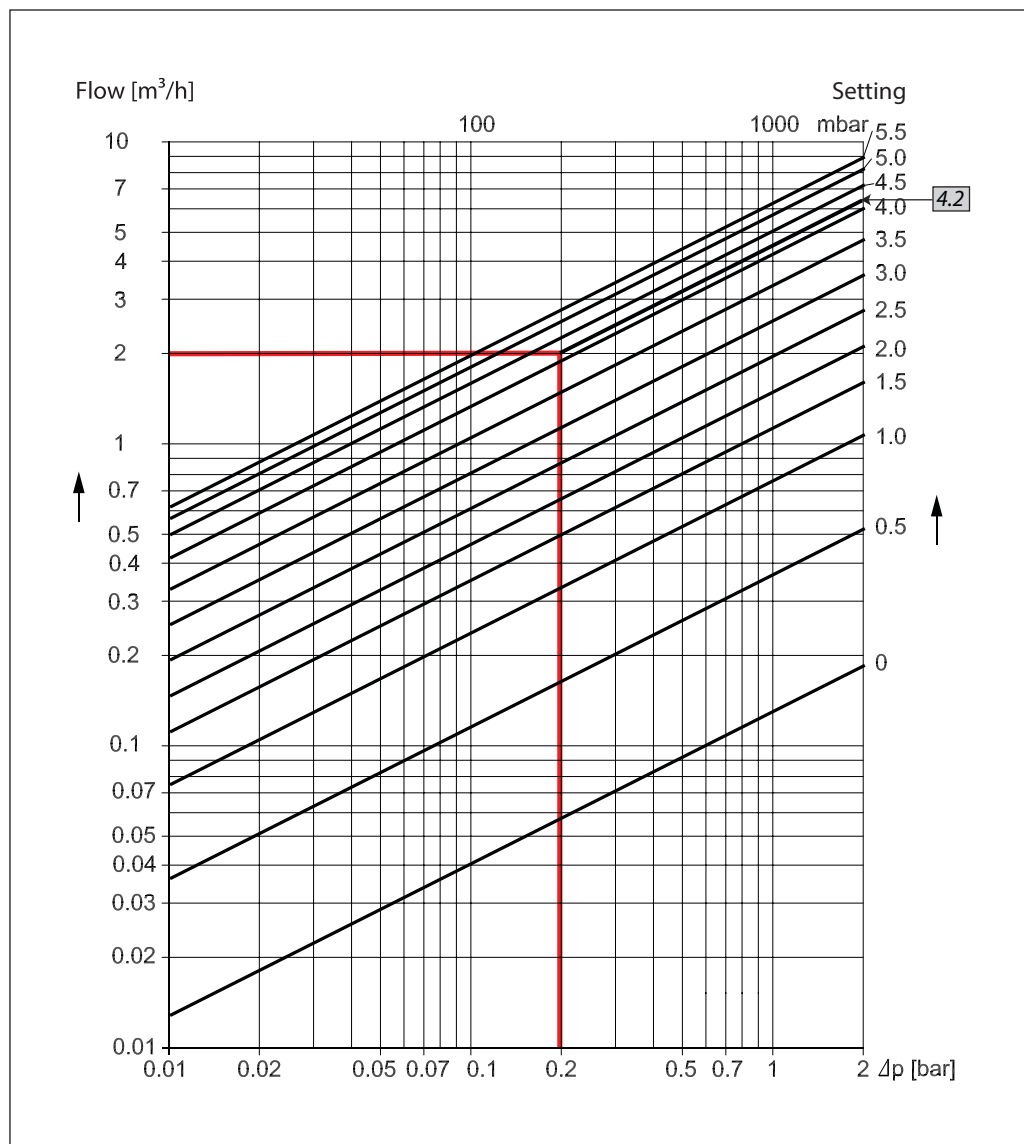

Flow characteristics

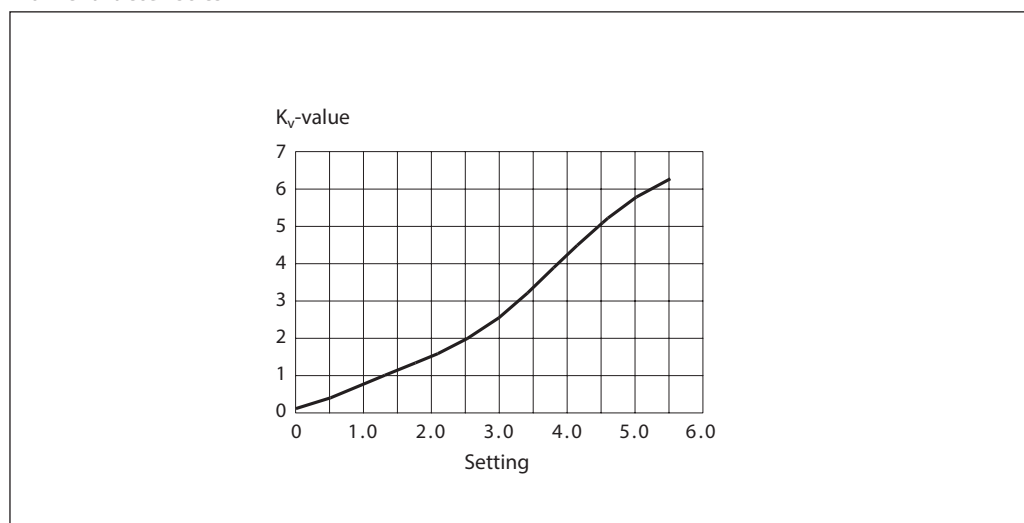

Flow Diagrammes, DN 25

Setting	k_v -value
0.0	0.33
0.1	0.44
0.2	0.53
0.3	0.61
0.4	0.68
0.5	0.74
0.6	0.79
0.7	0.85
0.8	0.91
0.9	0.96
0.10	1.03
1.1	1.09
1.2	1.16
1.3	1.24
1.4	1.32
1.5	1.41
1.6	1.50
1.7	1.60
1.8	1.70
1.9	1.80
2.0	1.91
2.1	2.03
2.2	2.15
2.3	2.26
2.4	2.39
2.5	2.51
2.6	2.64
2.7	2.76
2.8	2.89
2.9	3.02
3.0	3.15
3.1	3.28
3.2	3.41
3.3	3.54
3.4	3.68
3.5	3.81
3.6	3.95
3.7	4.09
3.8	4.24
3.9	4.39
4.0	4.55
4.1	4.71
4.2	4.88
4.3	5.05
4.4	5.23
4.5	5.42
4.6	5.62
4.7	5.83
4.8	6.05
4.9	6.27
5.0	6.51
5.1	6.75
5.2	7.00
5.3	7.26
5.4	7.53
5.5	7.80
5.6	8.06
5.7	8.33
5.8	8.59
5.9	8.84
6.0	9.08
6.1	9.30
6.2	9.50

LENO™ MSV-D DN 25

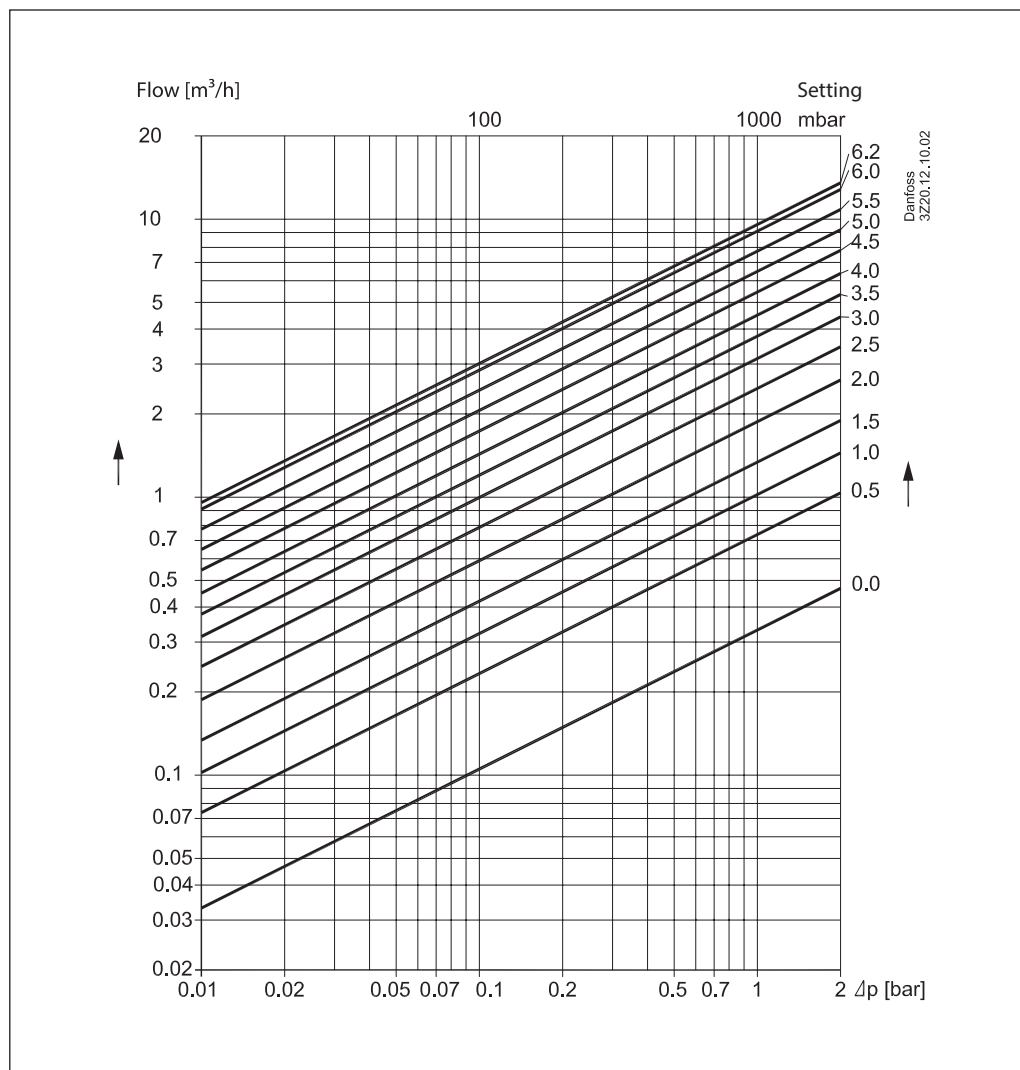

Flow characteristics

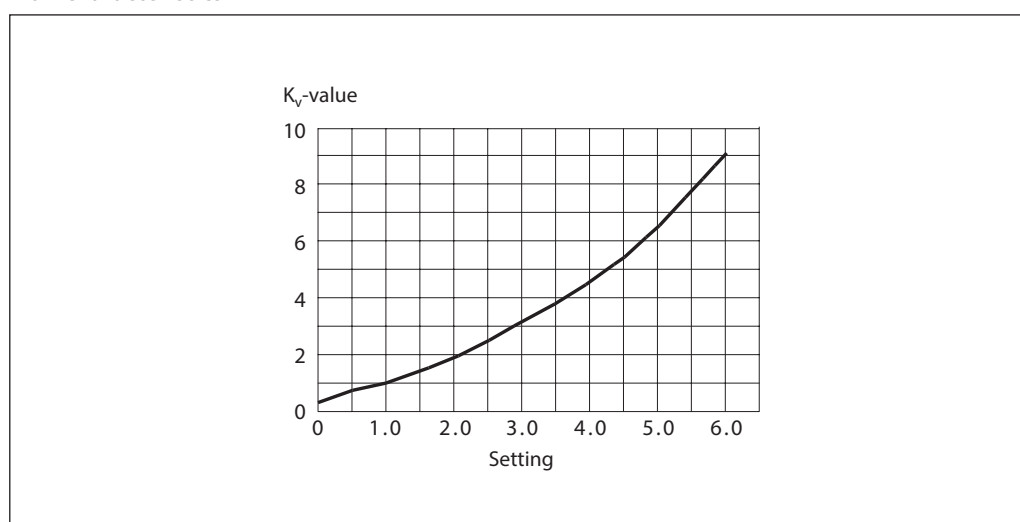

Flow Diagrammes, DN 32

Setting	k_v -value
0.0	0.50
0.1	0.75
0.2	0.95
0.3	1.13
0.4	1.29
0.5	1.45
0.6	1.62
0.7	1.80
0.8	1.99
0.9	2.20
0.10	2.42
1.1	2.66
1.2	2.92
1.3	3.19
1.4	3.47
1.5	3.75
1.6	4.05
1.7	4.36
1.8	4.67
1.9	4.98
2.0	5.30
2.1	5.63
2.2	5.97
2.3	6.32
2.4	6.68
2.5	7.06
2.6	7.46
2.7	7.89
2.8	8.34
2.9	8.83
3.0	9.35
3.1	9.92
3.2	10.52
3.3	11.16
3.4	11.85
3.5	12.51
3.6	13.23
3.7	13.98
3.8	14.74
3.9	15.49
4.0	16.23
4.1	16.91
4.2	17.51
4.3	18.00

LENO™ MSV-D DN 15 LF

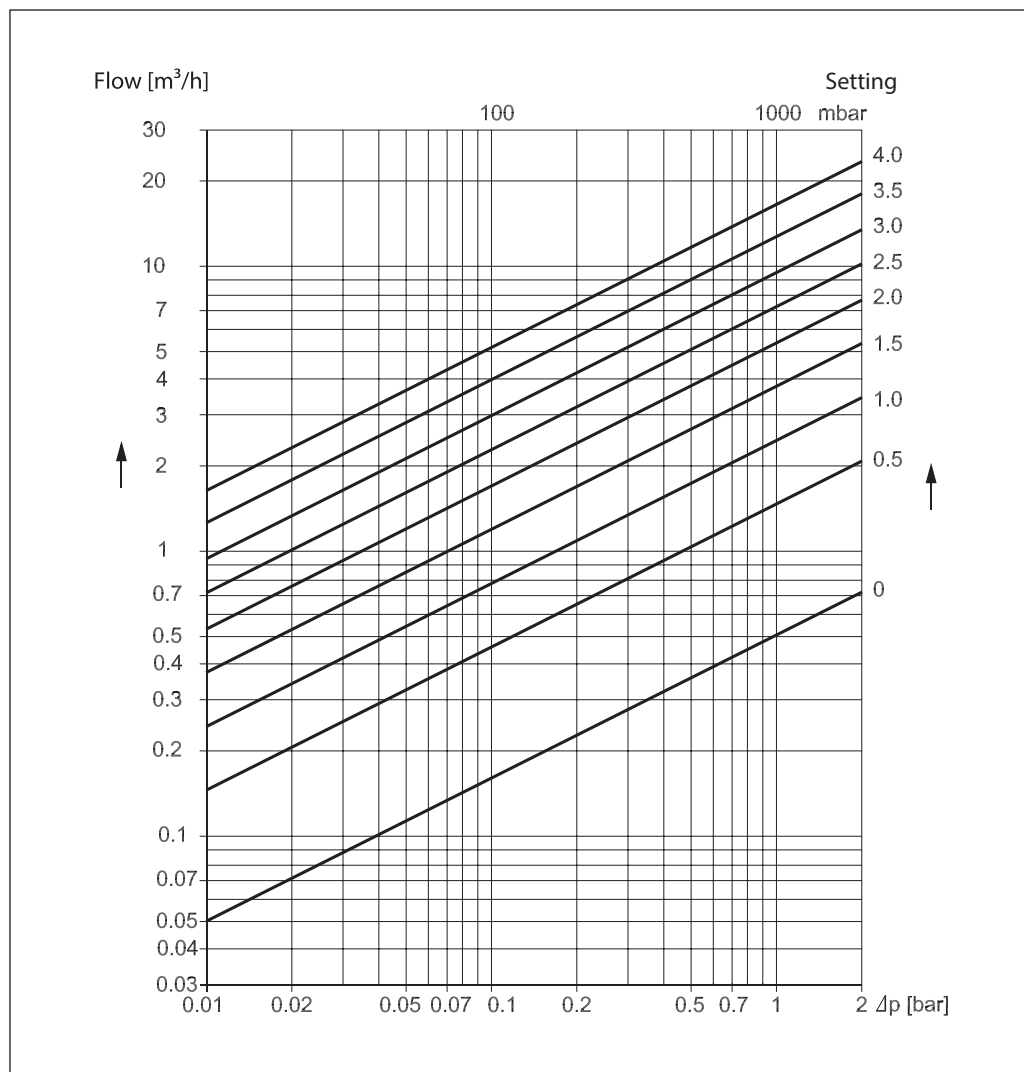

Flow characteristics

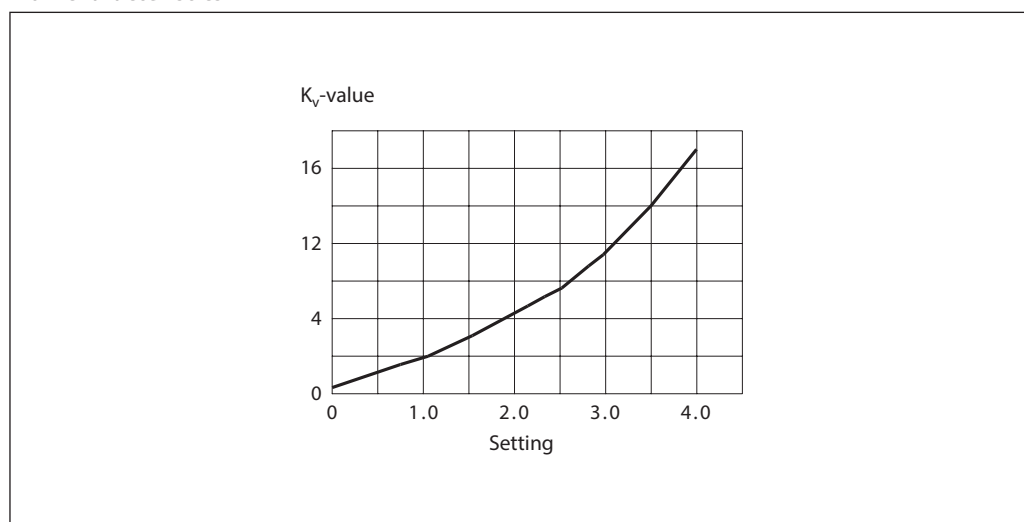

Flow Diagrammes, DN 40

Setting	k_v -value
0.0	1.06
0.1	1.21
0.2	1.38
0.3	1.56
0.4	1.76
0.5	1.97
0.6	2.20
0.7	2.43
0.8	2.68
0.9	2.93
1.0	3.19
1.1	3.46
1.2	3.73
1.3	4.01
1.4	4.29
1.5	4.58
1.6	4.87
1.7	5.17
1.8	5.47
1.9	5.78
2.0	6.09
2.1	6.41
2.2	6.74
2.3	7.09
2.4	7.44
2.5	7.80
2.6	8.18
2.7	8.58
2.8	9.00
2.9	9.44
3.0	9.90
3.1	10.38
3.2	10.89
3.3	11.43
3.4	12.00
3.5	12.60
3.6	13.22
3.7	13.88
3.8	14.56
3.9	15.28
4.0	16.02
4.1	16.79
4.2	17.57
4.3	18.38
4.4	19.19
4.5	20.02
4.6	20.82
4.7	21.61
4.8	22.38
4.9	23.12
5.0	23.81
5.1	24.44
5.2	25.00
5.3	25.46
5.4	25.80
5.5	26.00

LENO™ MSV-D DN 40

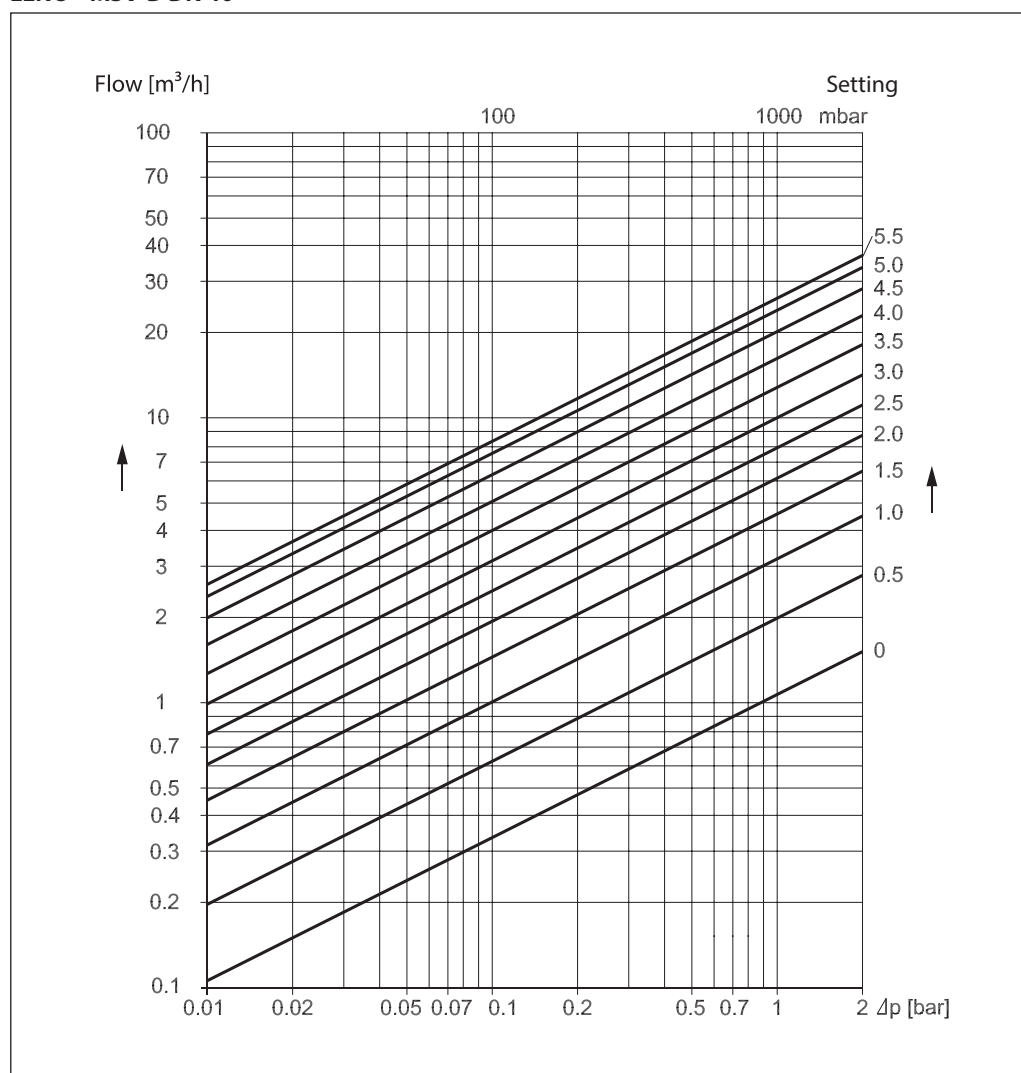

Flow characteristics

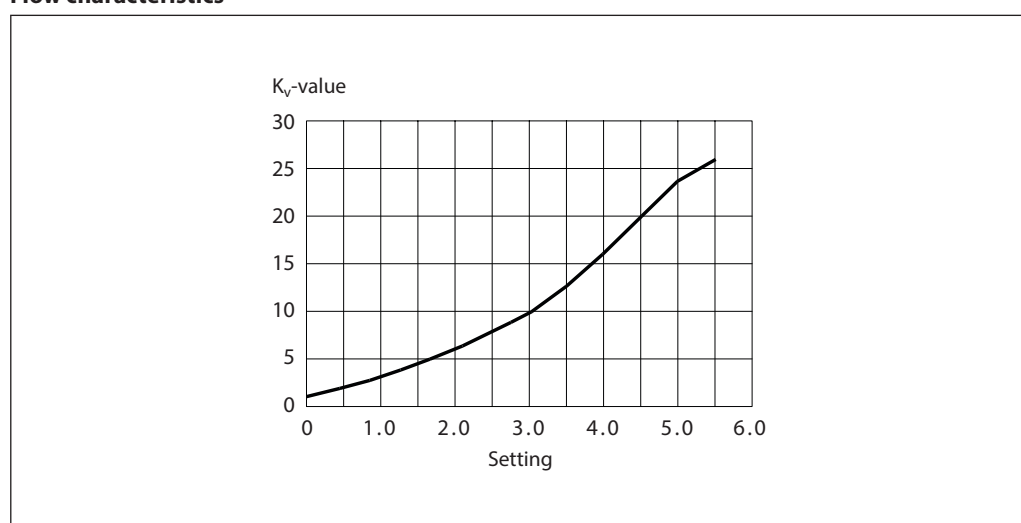

Flow Diagrammes, DN 50

Setting	k_v -value
0.0	1.74
0.1	2.03
0.2	2.28
0.3	2.51
0.4	2.73
0.5	2.95
0.6	3.16
0.7	3.38
0.8	3.61
0.9	3.85
1.0	4.10
1.1	4.37
1.2	4.65
1.3	4.95
1.4	5.26
1.5	5.59
1.6	5.93
1.7	6.28
1.8	6.64
1.9	7.01
2.0	7.39
2.1	7.78
2.2	8.17
2.3	8.56
2.4	8.96
2.5	9.36
2.6	9.76
2.7	10.17
2.8	10.58
2.9	10.99
3.0	11.41
3.1	11.84
3.2	12.27
3.3	12.71
3.4	13.16
3.5	13.62
3.6	14.10
3.7	14.60
3.8	15.12
3.9	15.66
4.0	16.23
4.1	16.84
4.2	17.47
4.3	18.14
4.4	18.84
4.5	19.59
4.6	20.38
4.7	21.21
4.8	22.08
4.9	23.00
5.0	23.96
5.1	24.96
5.2	26.00
5.3	27.07
5.4	28.17
5.5	29.30
5.6	30.44
5.7	31.64
5.8	32.83
5.9	34.01
6.0	35.14
6.1	36.23
6.2	37.24
6.3	38.14
6.4	38.93
6.5	39.56
6.6	40.00

LENO™ MSV-D DN 50

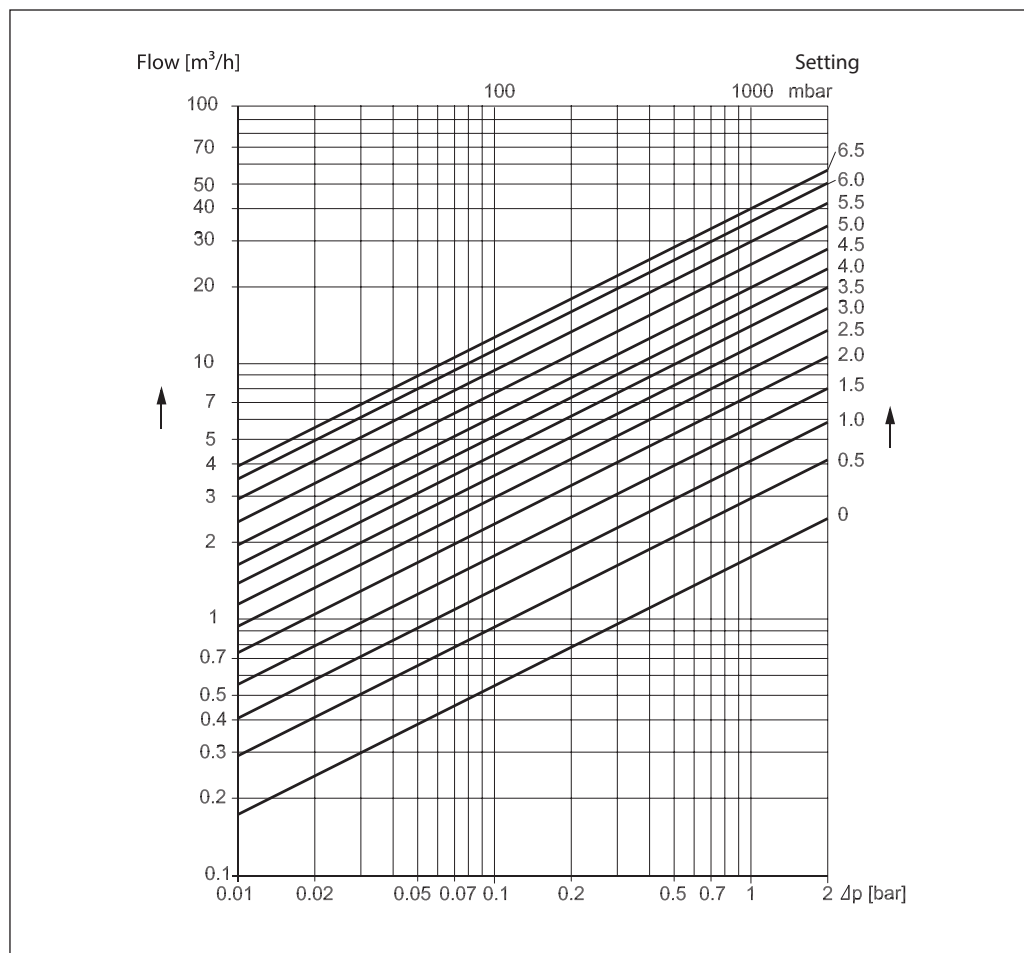

Flow characteristics

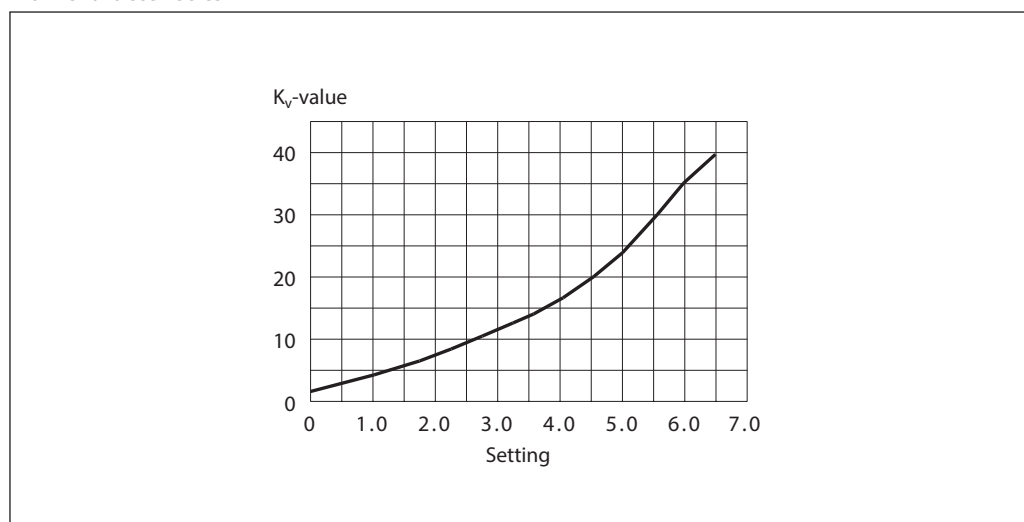

Dimensions

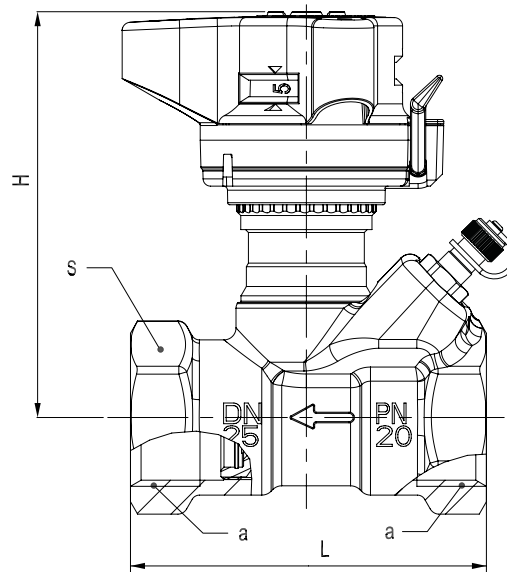

Size (DN)	Connections a (ISO 228/2)	L (mm)	H (mm)	S (mm)
15	G ½	76	92	27
20	G ¾	80	95	32
25	G 1	86	98	41
32	G 1¼	102	121	50
40	G 1½	102	125	55
50	G 2	130	129	67

Tender specifications

<i>Features</i>	<i>LENO™ MSV-D</i>
<i>Balancing/Commissioning</i>	•
<i>Presetting</i>	•
<i>Fixed orifice</i>	
<i>Self sealing measuring nipples</i>	•
<i>Digital visible scale from more sides</i>	•
<i>Shut off function (ball valve)</i>	•
<i>Draining/filling</i>	
<i>Draining/filling on both sides of the valve</i>	
<i>Removable handle</i>	•
<i>Closing indicator</i>	•
<i>Allen key for ball valve</i>	•
<i>Parallel measuring nipples</i>	•
<i>360° rotating measuring station (drain cock and measuring nipples)</i>	

Presetting values are visible on top of the valve and from all sides.
 Presetting is locked by pressing down the handle. When locked, the shut off function can be used without changing the presetting.
 The handle is released with the green key or with a 3 mm Allen key.
 To prevent unintended changes of the presetting, the handle can be sealed by using a strip.

The valve is bi-directional.

LENO™ MSV-D has a leakage rate A according to BS 7350 : 1990, the ball valve is 100% tight.

There are no requirements for inlet and outlet conditions.

The LENO™ MSV-D measuring accuracy is 10% up to 25% of max. setting.
 Accuracy is according to BS 7350 : 1990.

Measuring instruments must be equipped with 3 mm measuring needles. Danfoss measuring instruments PFM 100/1000 contain all relevant valve data.

Valve sizes..... DN 15 (LF) – DN 50
 Pressure class..... PN20
 Static test pressure..... 30 bar
 Working temperature..... -20°C to 120°C
 Working area..... 10-100% of the kvs-value

The valve body is made of CW617N brass.
 The ball is made of chromium plated brass.
 O-rings are made of EPDM rubber.



Danfoss A/S

Climate Solutions • danfoss.com • +45 7488 2222

Any information, including, but not limited to information on selection of product, its application or use, product design, weight, dimensions, capacity or any other technical data in product manuals, catalogues descriptions, advertisements, etc. and whether made available in writing, orally, electronically, online or via download, shall be considered informative, and is only binding if and to the extent, explicit reference is made in a quotation or order confirmation. Danfoss cannot accept any responsibility for possible errors in catalogues, brochures, videos and other material. Danfoss reserves the right to alter its products without notice. This also applies to products ordered but not delivered provided that such alterations can be made without changes to form, fit or function of the product.

All trademarks in this material are property of Danfoss A/S or Danfoss group companies. Danfoss and the Danfoss logo are trademarks of Danfoss A/S. All rights reserved.