

Fact Sheet

Ensure safe DC-grid selectivity with **VACON® NXP DCGuard™**



VACON® NXP DCGuard™* enables fast disconnection and full selectivity between DC grids.

Utilizing DC grids rather than AC grids enables power distribution with lower power losses. However, ensuring selectivity and limited short circuit energy requires more sophisticated protection devices.

Danfoss Drives has therefore developed the VACON® NXP DCGuard™, a semiconductor protection device that can detect and cut off any faulty DC currents and isolate the faulty part of the system in microseconds.

Current range:

- 465-800 VDC.....3-4140 A
- 640-1100 VDC.....4-3100 A

Easy dimensioning

Rated VACON® NXP DCGuard™ DC current = Rated VACON® NXP Inverter AC current.

This means that your primary dimensioning value is the required load through the VACON® NXP DCGuard™, meaning energy transfer from one side to another. It is as easy as that.

Type approvals:

DNV-GL, ABS, Lloyd's Register, CCS, Bureau Veritas

Current cut-off in
<5 μs



Feature	Benefit
Short circuit protection	Ensure correct system selectivity
Cuts off both + and - inside the same unit	No overvoltage spikes related to current cut-off
Controlled voltage ramp up	Connect two different DC grids with voltage differences up to full DC voltage
Overload detection	Protection of transmission cables
Standard NXP hardware	Proven and well known products

*patent pending

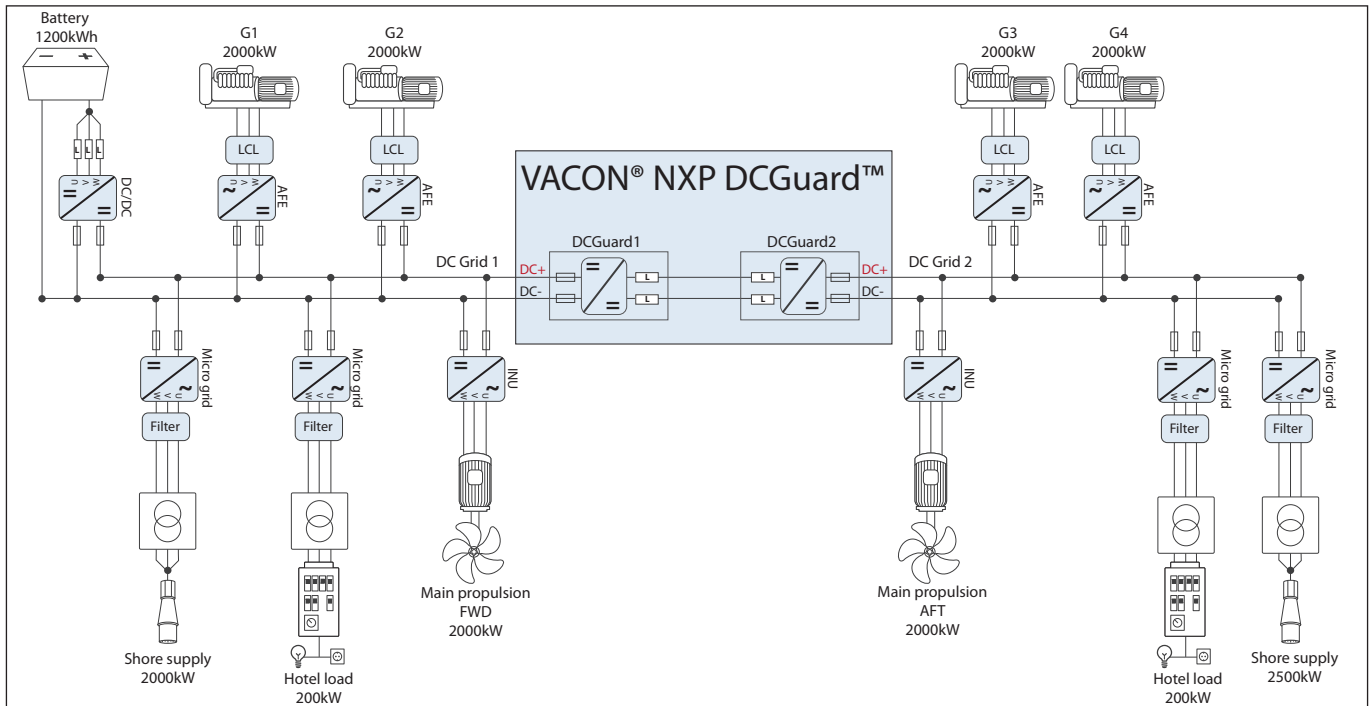

Example of hybrid system where VACON® NXP DCGuard™ ensures the required system selectivity

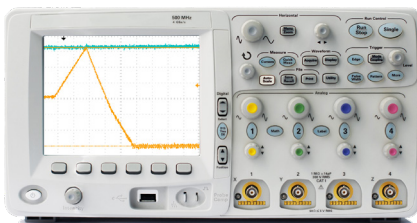

--- DC- link voltage on feeding side.
 Negligible voltage dip on feeding side.
--- DC current in connection cables.

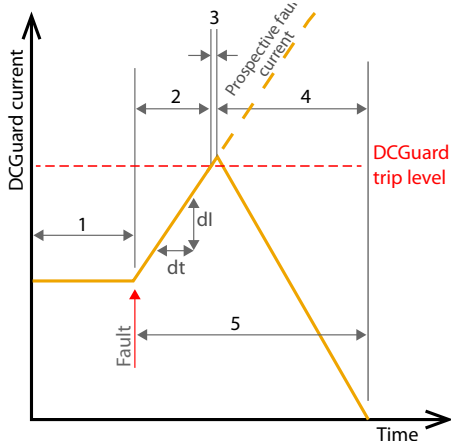

Legend

1. Normal situation(No fault)
Current is within DCGuard nominal current capacity.
2. Fault current rise time.
Current $di/dt=V/L$
 V =Feeding DC voltage
 L =Inductance in the circuit
Typical time:100-150 μ s*
3. Current cut off time.
DCGuard performs a current cut off by forcing all IGBTs open when current reaches the tripping limit of the DCGuard. Time:<5 μ s

4. Energy discharge time.
Current $di/dt=V/L$
 V =Feeding DC voltage
 L =Inductance in the circuit
Typical time:100-150 μ s*
 5. Total fault clearance time.
Typical time:200-300 μ s*
- * System dependent

Danfoss can accept no responsibility for possible errors in catalogues, brochures and other printed material. Danfoss reserves the right to alter its products without notice. This also applies to products already on order provided that such alterations can be made without consequential changes being necessary in specifications already agreed. All trademarks in this material are property of the respective companies. Danfoss and the Danfoss logotype are trademarks of Danfoss A/S. All rights reserved.