

Installation guide

Solenoid valve

Types EVR 32 - EVR 40 (Version 2)



032R9604

032R9604

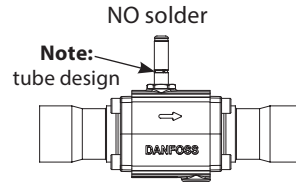
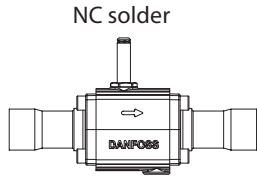

Refrigerants

R22/R407C, R134a, R404A/R507, R410A, R407A, R407F, R125, R152A, R448A, R449A, R452A, and R450A.
For complete list of approved refrigerants, visit www.products.danfoss.com and search for individual code numbers, where refrigerants are listed as part of technical data.

Note, please follow specific selection criteria stated in the datasheet for these particular refrigerants.

Max. working pressure

EVR solder: 45.2 bar.

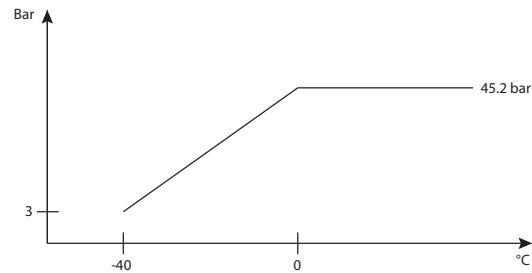

Max. working pressure in bar in relation to media temperature in °C.

Media temperature: -40 °C / -40 °F – 105 °C / 221 °F

Max. opening diff. pressure (MOPD): Coil dependent

Mounting

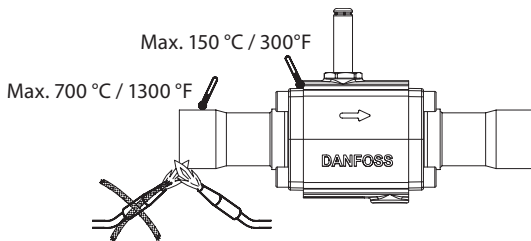

Mounting angle

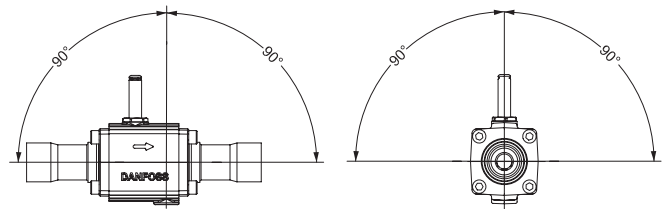

Always disconnect power from the coil when dismantled from the valve. The coil may be damaged and there is risk of injuries and burns.

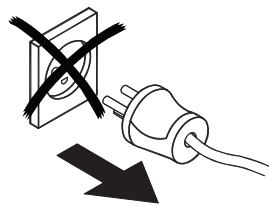

ID Marking - example

Valve identification and reference to UL listed coils

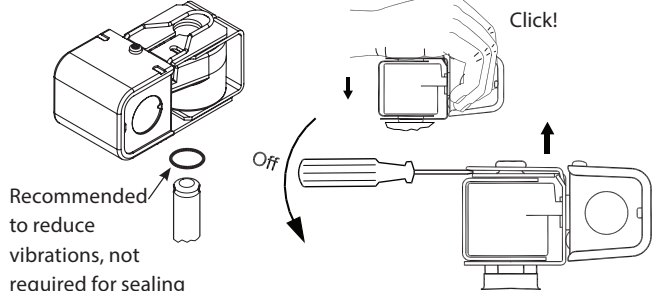
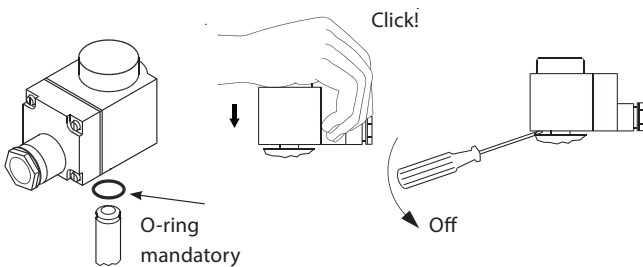

Імпортер: ТОВ з іі "Данфосс ТОВ" 04080, Київ 80, п/с 168, Україна

Info for UK customers only: Danfoss Ltd., 22 Wycombe End, HP9 1NB, GB

Disassembly and assembly of EVR version 2

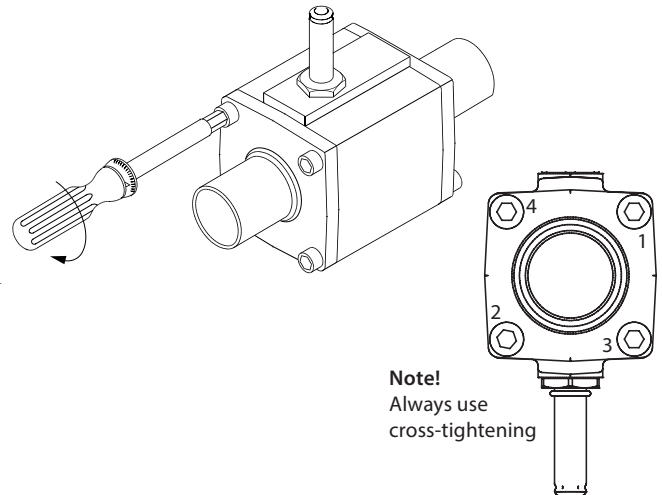
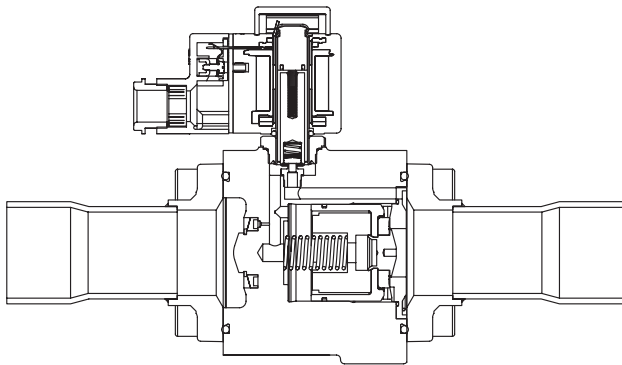

[Nm]	[kpm]	[ft-lbs]
30	2.0	15

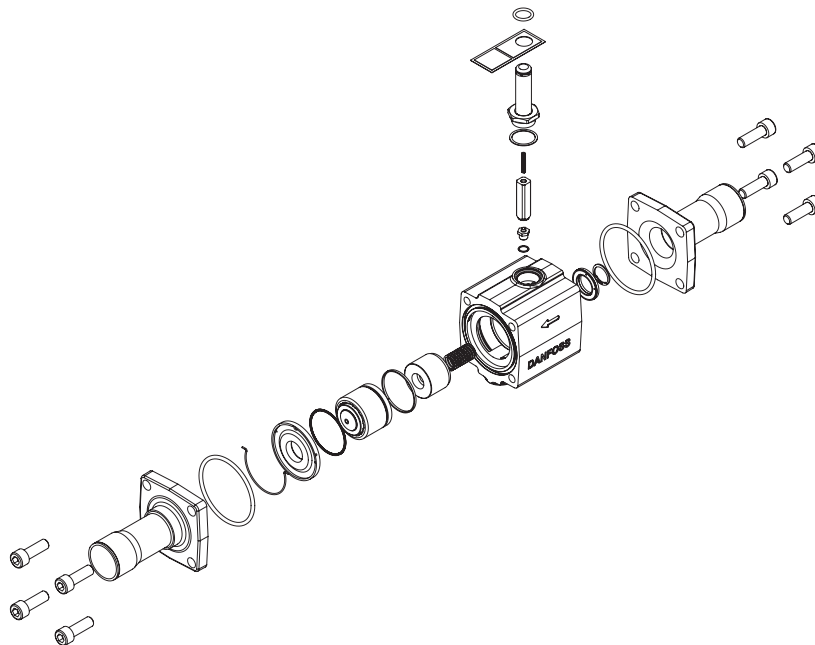
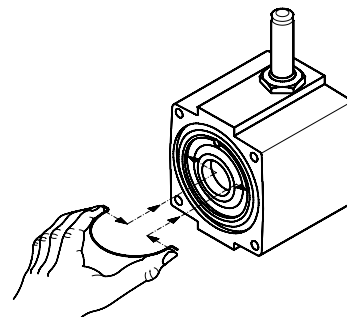
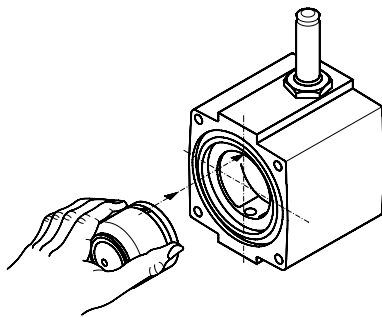

Manual operation for pressure testing and service related operation:

Only use the manual stem operation of the EVR NC valve during initial pressure testing of the refrigeration system or during service related manual operation. Remove the protective cap and rotate the manual stem clockwise approx. 6 cycles from fully closed to fully open position. After the manual operation is completed, ensure to rotate the manual stem counter-clockwise back to fully closed position and re-mount the protective cap before connecting the valve to automatic operation. MOPD for the manual operation function is 5 bar. Alternatively, all EVR NC and NO valves can be manually operated by removing the coil and force the valve open or closed by using a solenoid valve tester (permanent magnet).