

ENGINEERING
TOMORROW

Danfoss

Application guide

Industrial Refrigeration systems in Potentially Explosive Atmospheres

(Hazardous area) ATEX 2014/34/EU Directive
[ATmosphères EXplosives]



www.danfoss.com/ir

Contents

Contents

Introduction 3

Disclaimer 3

Application area for ATEX and Harmonised Standards 3

Gas Zones 3

Scope of ATEX 4

Non-electrical equipment 6

Electrical equipment 6

Marking 7

Documentation 7

Equipment group and zones 8

Products approved acc ATEX directive 8

Hazards area classification (zone classification) 9

Common standard for determine hazardous zones classification for systems with flammable refrigerants 10

Sealing materials 10

ANNEX I 11

Equipment Groups and Temperature Classes - EXPLOSION PROOF SOLENOIDS 11

ANNEX II - Classification of Danfoss Industrial Refrigeration products 13

ANNEX III - Manufacturer's declaration for potentially explosive atmospheres 14

Examples of Manufacturers / EU declarations 16

ANNEX IV 16

Valves for HC-refrigerants 16

ANNEX V 17

ICS3E valves 17

SV3E valves 18

CVPE valves 19

CVCE valves 20

EVME valves 21

Introduction

Industrial refrigeration components are typically used in ammonia refrigeration systems, but some components are used in related applications, where locations are classified as hazardous areas.

Danfoss has over several years supplied components to this business area, particularly in Europe. However, due to new, more restrictive regulations, refrigeration components and refrigeration systems must fulfil requirements for potentially explosive atmospheres, as specified in the ATEX directive. PRS systems (Process Refrigeration Systems) are typically classified as hazardous areas, where the ATEX requirements also must be fulfilled.

The ATEX 2014/34/EU directive is one of the “new” European directives. The ATEX directive specifies the requirements for equipment intended for use in potentially explosive atmospheres.

The ATEX directive is mandatory in all EU and EFTA member states.

Disclaimer

This application guide has been developed based on present European directives and standards in order to describe relevant solutions for industrial applications.

Danfoss do not take any responsibility of specific application solutions. It is the designer of the system that has the responsibility to ensure compliance with all relevant requirements..

Application area for ATEX and Harmonised Standards

The ATEX as well as the harmonised technical standards state requirements for:

- Design of equipment / manufacture of equipment / testing of equipment
- Compliance with the ATEX directive ensures free movement of goods / equipment between all EU-member states and it also ensures that the equipment can be put into service, if there are no particular requirements for the country of destination.
Important! - The zone classification for the country of destination of a final refrigeration system has to be approved by local authorities. If local authorities require higher classification than the actual equipment is approved for, the system must not be used
- Installation and start up

The ATEX directive does not state requirements for:

- **Operation** – When the equipment is operating at the end-users facility, national laws become effective

Gas Zones

Gas Zones				
Gas Zones	Definition	ATEX Category	EPL	Required Protection
Zone 0	Explosive atmosphere present continuously or for long periods, frequently	1G	Ga	Two Faults
Zone 1	Explosive atmosphere is likely to occur under normal conditions, occasionally	2G	Gb	One Fault
Zone 2	Explosive atmosphere is unlikely to occur under normal conditions, short periods	3G	Gc	Normal Operation

Fig. 1 Gas zones

Scope of ATEX

Included in the ATEX Directive: -

- Mining and non-mining equipment
- Explosive atmospheres caused by gas and dust
- Electrical and non-electrical equipment
- Equipment (machines, devices, built-in instruments or mobile devices)
- Security systems (equipment which can stop / limit explosions)
- Components (parts without any independent function)
- Security control and regulation devices intended for use outside explosive areas, but which secure the equipment in the hazardous areas

Not included in the ATEX Directive: -

- Medical equipment for hospital environments
- Equipment and protection systems for use in connection with explosive or unstable chemicals
- Household appliances and equipment intended for use in non-commercial surroundings
- Personal Protection Equipment directive
- Tankers and mobile offshore units.
- Means of transport except vehicles

Equipment for mining industries and explosive atmospheres caused by dust are not covered in this application guide.

Non-mining equipment for potential explosive atmospheres; classified as:

Equipment Group II.

- Category 1
- Category 2
- Category 3

The requirements in the categories depend on the type of equipment.

- Simple mechanical components like valves, filters, check valves, etc. do normally not contain any potential ignition source, and are therefore not covered by the ATEX-directive. Manufacturers of this kind of equipment, must

nevertheless carry out and keep a risk assessment report, to prove that the equipment does not have an ignition source and are safe for the purpose

- Mechanical components with potential ignition sources e.g. components containing nonconductive materials, are covered by the ATEX-directive. These products must fulfil all requirements in the ATEX directive and must be marked with the required ⚡ marking
- Electrically operated components are covered by the ATEX-directive and have to fulfil all requirements in the ATEX directive and have to be marked with the required ⚡ marking

	Non electrical valve <u>without</u> potential ignition source	Non electrical valve <u>with</u> potential ignition source	Electrical operated valve
	 <ul style="list-style-type: none"> • Stop valves • Filters • Check valves • Etc. 	 <p>Not relevant for common industrial refrigeration components</p>	 <ul style="list-style-type: none"> • Electronic comp. • Coils • Etc.
Category 1 (Zone 0)	Not covered by the scope of ATEX Directive 2014/34/EU	CE-Type approval III + IV or V	CE-Type approval III + IV or V
Category 2 (Zone 1)		Documentation at Notified Body (VIII partly)	CE-Type approval III + IV or VII
Category 3 (Zone 2)		Internal quality control (VIII)	Internal quality control (VIII)
--			

Fig. 2 - ATEX-requirements

NOTE:

The letters I, II, ... VIII in figure 2, specify the relevant ATEX 2014/34/EU directive "modules" that need to be complied with.

Explosion triangle for gas

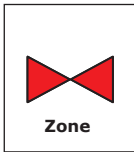
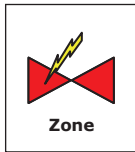
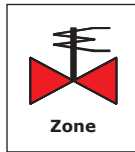
The explosion triangle (fig. 3) shows the principle of explosion. All three elements must be present before an explosion can take place.

Removing one of the elements eliminates all risk of explosion.

In refrigeration, the consideration regarding the risk of explosion is limited to the outside of the system itself. Within the refrigeration system, there is 100% concentrated refrigerant with no oxygen present, consequently there is no risk of explosion.

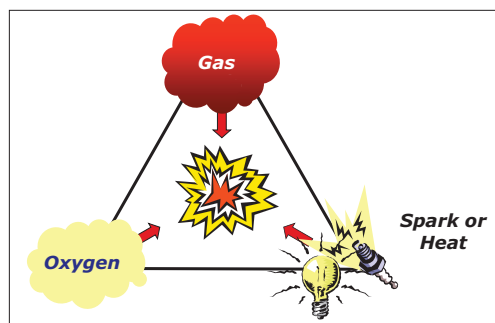

Fig. 3 - The explosion triangle

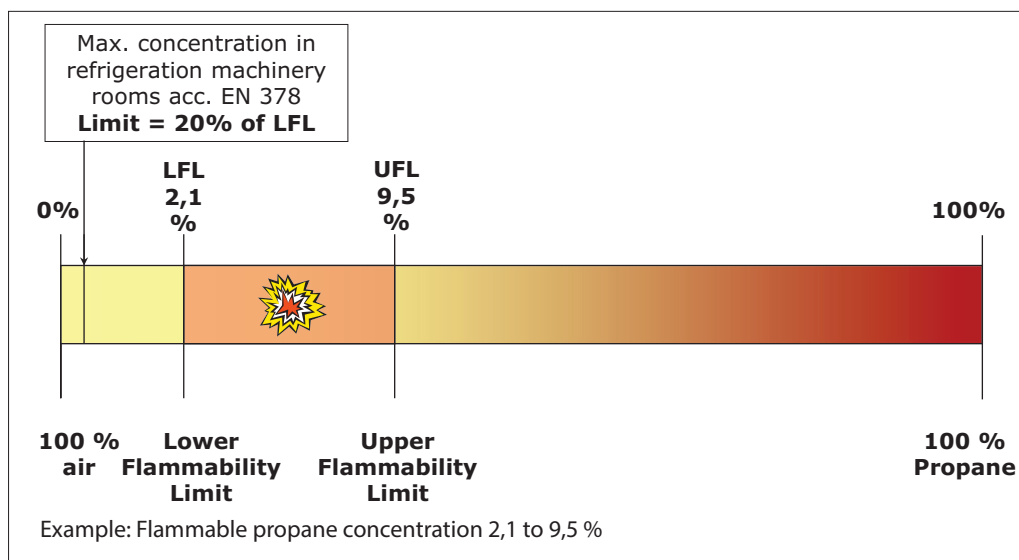

Fig. 4 Flammable concentration

Non-electrical equipment

The risk analysis of non-electrical refrigeration equipment (valves and similar components) must focus on ignition sources. The requirements risk assessment for this kind of equipment must be conducted acc. EN/ISO 80079-36.

- Examples:
- Non-conductive materials (e.g. plastic) are *not acceptable*. Non-conductive material can create "static electricity".
 - Magnesium content
 - Hot surfaces
 - All possible sources of ignition must be analyzed and avoided

Simple components like stop valves, filters etc. without the above-mentioned ignition sources, are normally not covered within the scope of the ATEX directive.

Electrical equipment

The requirements for electrical equipment in hazardous areas are not new. The requirements specified in the ATEX directive are almost identical with the previous legislation and are much more demanding than the requirements for non-electrical equipment.

Several different methods can be used to protect electrical equipment. Detailed below are two commonly used methods of electrical protection.

Intrinsic safety protection method

Intrinsic safety is an explosion protection technique ensuring there is insufficient energy to cause the ignition of a surrounding explosive atmosphere by an electrical spark or the heating of components or circuitry.

Due to power consumption restrictions, this method is only suitable for equipment with low power consumption and is commonly used for measuring devices.

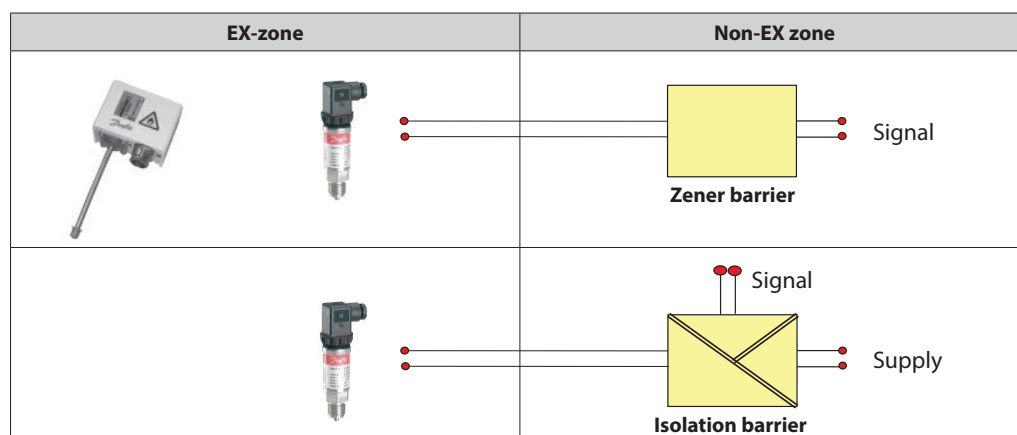

Fig. 5 - Intrinsic safety protection method

Encapsulation

Encapsulation is an explosion protection technique where the electrical components are fully encapsulated. This method is often used for components with "higher" power consumption e.g. solenoid coils. However, power consumption is also a limiting factor with this method due to the risk of "high" surface temperature of the component.

Note:

Solenoid valves with these coils can have relatively low MOPD .

Marking

Components covered within the scope of the ATEX directive have to be CE-marked, and marked with the specific - sign. The marking depends on the actual type of equipment.

Marking										
		Specific marking				Additional marking				
CE	9999		II	2	G	EX	d	IIC	T4	Gb
CE-mark	CE-Registration number of Notified Body	Epsilon x marking for equipment for use in explosive atmospheres.	Equipment group: I Mining II Non-mining	Equipment Category: 1 (zone 0) 2 (zone 1) 3 (zone 2)	Nature of atmosphere: G Gas D Dust	Protection type: Electrical apparatus, gas atmospheres: "d": Flameproof enclosure EN 60079-1 (da/db/dc) "e": Increased safety EN 60079-7 (ea/eb/ec) "n": Non-flammable EN 60079-15 (na/nC/nR) "m": Protection by encapsulation EN 60079-18 (ma/mb/mc)	Gas Group: IIA IIB IIC	Temperature class: T1 to T6	Protection type: Equipment Protection Level (EPL) Ga Gb Gc	

Fig. 6 - -marking

Documentation

The required documentation depends on whether the component has an ignition source or not.

All components covered within the scope of the ATEX directive must be supplied with a CE declaration of conformity.

Non-electrical equipment without any ignition source, is not covered within the scope of the ATEX directive but must be supplied with the manufacturer's declaration.

The manufacturer's declaration must declare that the equipment is suitable for the purpose, and that it does not have any ignition sources. The manufacturer also has the obligation to document a safety risk assessment for the equipment.

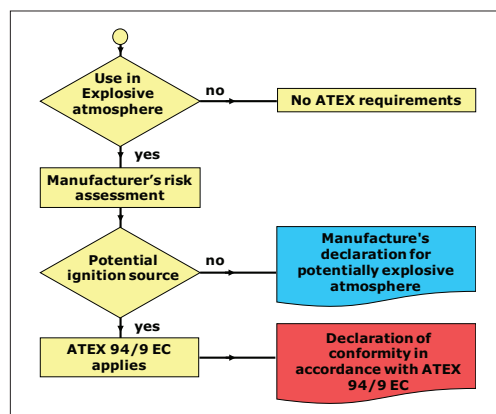

Fig. 7 - Documentation

Equipment group and zones

Equipment located in zone specified areas must fulfil the following requirements:

- Category 3 - approved equipment can be installed in hazardous areas zone 2 and outside zone categorized areas
- Category 2 - approved equipment can be installed in hazardous areas zone 1, zone 2 and outside zone categorized areas
- Category 1 - approved equipment can be installed in hazardous areas zone 2, zone 1, zone 0 and outside zone categorized areas

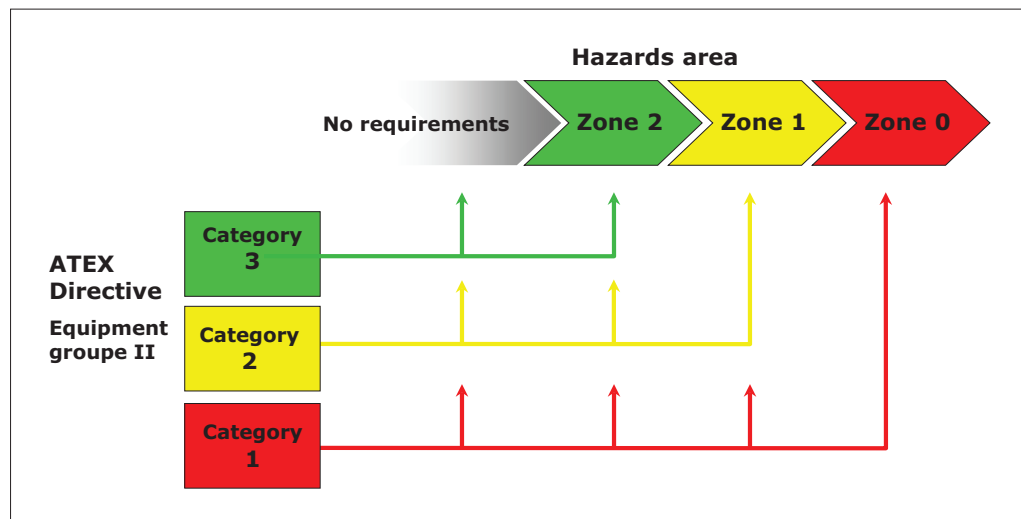

Fig. 8 - Category relations

Products approved acc ATEX directive

Solenoid coil type BO	CE ₀₅₃₉ Ex II 2G Ex mb IIC T4 Gb	Zone 1
Solenoid coil type BZ	CE ₀₅₃₉ Ex II 2G Ex mb IIC T4 Gb	Zone 1
Pressure transducer type AKS 32,32R,33 & EMP2	CE Ex II 3G Ex nA IIA T3 Gc	Zone 2
Pressure transducer type MBS 4201 & 4251	CE ₀₅₃₉ Ex II 1G Ex ia IIC T6..T4 Ga	Zone 0
Gas detector Type GD HeavyDuty	CE ₀₁₅₈ Ex II 2G Ex db IIC T4 Gb	Zone 1
Pressure & Temperature switches RTxxxE	CE ₀₅₃₉ Ex II 2G Ex ia IIC T6..T1 Gb	Zone 1

Fig. 9 Danfoss products approved according to ATEX directive

Hazards area classification (zone classification)

- In most practical situations where flammable substances are used, it is difficult to ensure that an explosive gas atmosphere will never occur, and equipment will never give rise to a source of ignition, therefore it is important to conduct a Hazards area classification (zone classification), which is a method of analysing and classifying the environment where the explosive gas atmosphere may occur (risk assessment).

Zone classification has two main objectives:

- Determine the type of any zone (0,1 and 2), where zone 0 has the highest risk of creating an explosive atmosphere.
- Determine the extent (size) of the zone.

The zone assessment may also lead to zone NE – zone of negligible extent (if ignition occur it would have negligible consequences).

Refrigerant systems are typically classified in various zones with various extent (size) according to the risk of the actual part of the system

Some important factors when conducting zone classification of flammable refrigerants (risk of creating an explosive atmosphere):

- Leak probability
- Leak rate (hole size)
- Leak duration (like time or continuously like)
- Leak form (liquid phase, gas phase)
- Leak pressure
- Refrigerant properties (flammability levels)
- Ventilation rate / dilution

For refrigeration systems, special considerations must be taken:

- “Potentially explosive atmospheres” do not occur inside a refrigeration system because no oxygen is present. (Refrigeration systems designed and maintained according to EN 378 fulfil this requirement).
- “Potentially explosive atmospheres” can occur outside a refrigeration system (in the location of a refrigeration system).
- Refrigeration systems containing flammable refrigerants (e.g. Propane) shall be detailed assessed for possible leak sources which may create “Potentially explosive atmospheres”.
- Refrigeration systems contain non- flammable refrigerants (e.g. CO₂), may be located in “Potentially explosive atmospheres”. Any possible leak sources from these systems do not increase the risk profile for the system.

Note1: It is the end-user’s responsibility that a proper risk assessment with specification of hazardous zones is made according to the requirements in the local legislation.

Based on actual zone requirement for a refrigerant system, the required ATEX approval level (zone) can be defined for the individual components in the system.

Note2: It is the component manufacturer responsibility to document that product released for use in “Potentially explosive atmospheres” (zone 2, zone1 or zone 0), complies to the requirement.

- For all non-electrical equipment in “Potentially explosive atmospheres”, an ignition assessment acc. to EN ISO 80079-36 must be conducted and concluded that the product do not contain any ignitions sources under normal operation (ATEX Manufacturing certificate).
- For all electrical equipment in “Potentially explosive atmospheres”, the product must have an ATEX-type approval valid for the actual application. (ATEX Type approval certificate).

Common standard for determine hazardous zones classification for systems with flammable refrigerants

Common standard for determine hazardous zones classification is EN / IEC 60079-10-1.

The standard defines various steps to be evaluated e.g:

1. Identify sources of release
2. Determine the release rate and grade of release for each source based on likely frequency and duration of release
3. Assess ventilation or dilution conditions and effectiveness
4. Determine zone type based on grade of release and ventilation or dilution effectiveness
5. Determine extent of zone

Some examples:

Add. 1

Typical release sources in refrigerant systems:

- Leak from flange connections
- Leak from valve spindle seals
- Leaks from safety valves (discharge lines)
- Leaks sources when servicing systems with multiple compressors

Add. 2

Reliable leak rates for various parts of a system are difficult to determine. Leak rates may be approached by calculation or test, considering appropriate statistical and numerical assessments for the factors concerned, for each source of release.

Note: EN / IEC 60079-10-1 contains various formulars relevant to determine the release rates, required ventilations etc. The standard also contains tables with simplified methods which can be very helpful for evaluating various systems.

Sealing materials

Special attention need to be paid to some hydrocarbons because they are not compatible with commonly used O-rings used in refrigeration systems. Figure 10 shows the most typical hydrocarbons, and that Propylene is NOT compatible with CR-O-rings.

Note: Special products with Viton O-rings are shown in annex IV & I of this document.

Hydrocarbon refrigerants	Neoprene / CR (chloroprene) Used for standard refrigeration valves	Fluorocarbon FPM (Viton) NOTE ¹⁾
Ethane R170	+	(+) ²⁾
Propane R290	+	(+) ²⁾
Butane R600	+	(+) ²⁾
Isobutane R600a	+	(+) ²⁾
Propylene R1270		+

Fig. 10 - Material compatibility (sealing material / O-rings)

¹⁾ There are no FPM O-rings available for low temperature (below -40 °C)

²⁾ Valve / refrigerant marked with (+) indicate that the valve is compatible with the refrigerant, but a standard valve with Chloroprene O-rings can also be used.

ANNEX I

Equipment Groups and Temperature Classes - EXPLOSION PROOF SOLENOIDS

For the types of protection “d” and “i”, group II is subdivided into IIA, IIB, IIC. Electrical apparatus certified for IIB may be used in applications requiring apparatus to be certified for group IIA. Electrical apparatus certified for IIC may be used in applications requiring apparatus to be certified for groups IIA and IIB.

For example the “d” and “i” types of protection are respectively subdivided according to the Maximum Experimental Safe Gap (MESG) and to the Minimum Igniting Current (MIC). Electrical apparatus certified for IIB may be certified for use with a gas belonging to group IIC. In this case, the identification is supplemented with the chemical symbol or the name of the gas (example: Ex d IIB + H₂ according to EN 60079-0 and EN 60079.1). The table below indicates the groups to which some gas mixtures belong:

Groups	Gas	Ignition temperature ¹⁾ (°C)	Temperature class							
			T1	T2	T3	T4	T5	T6		
I	methane (firedamp)									
II	A	acetone	540	•						
		acetic acide	485	•						
		ammonia	630	•						
		ethane	515	•						
		methylene chloride	556	•						
		methane (CH ₄)	537	•						
		carbon monoxyde	605	•						
	propane	470	•							
	B	n-butane n-butyl	365		•					
			370		•					
		n-hexane	240			•				
		acetaldehyde ethyl ether	140				•			
			160				•			
	ethyl nitrite	90							•	
	C	ethylene	425		•					
			429 - 440		•					
		hydrogen sulfide	270			•				
C	acetylene (C ₂ H ₂)	305		•						
		carbon disulphide (CS ₂)	102						•	
	hydrogen (H ₂)	560	•							

TEMPERATURE CLASS

The temperature classification is based on the maximum surface temperature of equipment. That is the highest temperature any part of or the entire surface of an electrical device can reach under the most unfavourable operating conditions capable of igniting a surrounding explosive atmosphere.

- preferably with the temperature class (T classification)
- defined by the surface temperature or,
- limited to the specified flammable gases or dusts for which it is approved, if necessary (and marked accordingly).

Temperature class	Maximum surface temperature (°C)	Ignition temperature ¹⁾ (°C)
T1	450	>450
T2	300	>300
T3	200	>200
T4	135	>135
T5	100	>100
T6	85	>85

- ¹⁾ Temperature of a hot surface able to ignite a gas mixture.
 The ignition temperature of the gas mixture must be higher than the maximum surface temperature. In practice, a 10 to 20% safety margin is observed between the ignition temperature and the rated nameplate temperature.
 The ignition temperature of a cloud of dust is generally between 300 °C and 700 °C. At 150 °C to 350 °C, the ignition temperature of a layer of dust is far below that of a dust cloud. A burning dust layer can initiate a dust explosion if brought in contact with a combustible dust cloud, so these values must be taken into account to limit the risk.

ANNEX II - Classification of Danfoss Industrial Refrigeration products

Danfoss product Group		Products / refrigerants / ATEX overview. 27-02-2023										ATEX approvals					
		Safety class:		B2L		A1		A3		A3		A3		ATEX Equipment Group		Hazards area	
Product type		Refrigerant type:		Ammonia		CO ₂		Ethane		Propane		Butane		Isobutane		Propylene	
		Refrigerant name:		R717		R744		R170		R290		R600		R600a		R1270	
		Product family															
A	Check valve	NRVA	X														
A	Filter	FIA, FIA SS, FIA-65B	X	X	X	X	X	X	X	X	X	X	X	X	X	X	X
A	Filter	FIA-140B		X													
A	Stop valve	SVA, SVA-65-B, SVA65BT, SNV	X	X	X	X	X	X	X	X	X	X	X	X	X	X	X
B	Change over valve	DSV	X	X	X	X	X	X	X	X	X	X	X	X	X	X	X
B	Check valve	CHV, CHV SS, CHV-65B	X	X	X	X	X	X	X	X	X	X	X	X	X	X	X
B	Float valve	HFI, SV HP, SV LP	X														
B	Overflow valve	POV + BSV	X	X	X	X	X	X	X	X	X	X	X	X	X	X	X
B	Pilot	CVC, CVP, CVPP	X	X	X	X	X	X	X	X	X	X	X	X	X	X	X
B	Regulating valve	REG, REG SS, REG-65B	X	X	X	X	X	X	X	X	X	X	X	X	X	X	X
B	Safety valve	BSV, SFA, SFV	X	X	X	X	X	X	X	X	X	X	X	X	X	X	X
B	Safety valve	SFA H		X													
B	Stop-Check valve	SCA, SCA SS, SCA-65B	X	X	X	X	X	X	X	X	X	X	X	X	X	X	X
C	Control valve-pilot operated	ICS, ICSH	X	X	X	X	X	X	X	X	X	X	X	X	X	X	X
C	Expansion valve-electronic	AKVA	X	X													
C	Multifunction valve	ICF	X	X													
C	Multifunction valve	ICF EVRA	X														
C	Multifunction valve	ICF EVRAT	X														
C	Pilot-electronic	EVM	X	X	X	X	X	X	X	X	X	X	X	X	X	X	X
C	Solenoid valve	EVRA, EVRAT, EVRS, EVST	X														
C	Solenoid valve (2-step)	ICLX, ICSH	X	X	X	X	X	X	X	X	X	X	X	X	X	X	X
D	Control valve-with pilot - HC	ICSE			(X)	(X)	(X)	(X)	(X)	(X)	(X)	(X)	(X)	(X)	(X)	(X)	(X)
D	Float valve - HC	SV3E			(X)	(X)	(X)	(X)	(X)	(X)	(X)	(X)	(X)	(X)	(X)	(X)	(X)
D	Pilot - HC	CVCE			(X)	(X)	(X)	(X)	(X)	(X)	(X)	(X)	(X)	(X)	(X)	(X)	(X)
D	Pilot - HC	CVPE			(X)	(X)	(X)	(X)	(X)	(X)	(X)	(X)	(X)	(X)	(X)	(X)	(X)
D	Pilot-electronic - HC	EVME			(X)	(X)	(X)	(X)	(X)	(X)	(X)	(X)	(X)	(X)	(X)	(X)	(X)
E	Damper	ICD	X														
E	Filter	FA	X														
E	Level sensor- electronic	AKS 4100	X	X													
E	Level switch- electronic	LLS	X														
E	Motorized valve	ICM+ICAD	X	X													
E	Motorized valve	ICMTS+ICAD		X													
E	Pilot valve-electronic	CVE+ICAD	X	X													
F	Solenoid coil type BO	CE ₀₅₃₉ Ex II 2G Ex mb IIC T4 Gb	X	X	X	X	X	X	X	X	X	X	X	X	X	X	X
F	Solenoid coil type BZ	CE ₀₅₃₉ Ex II 2G Ex mb IIC T4 Gb	X	X	X	X	X	X	X	X	X	X	X	X	X	X	X
F	Pressure transducer type AKS 32,32R,33 & EMP2	CE ₀₅₃₉ Ex II 3G Ex nA IIA T3 Gc	X	X	X	X	X	X	X	X	X	X	X	X	X	X	X
F	Pressure transducer type MBS 4201 & 4251	CE ₀₅₃₉ Ex II 1G Ex ia IIC T6..T4 Ga	X	X	X	X	X	X	X	X	X	X	X	X	X	X	X
F	Gas detector Type GD Heavy Duty	CE ₀₁₅₈ Ex II 2G Ex db IIC T4 Gb	X	X	X	X	X	X	X	X	X	X	X	X	X	X	X
F	Pressure & Temperature switches RTxxxE	CE ₀₅₃₉ Ex II 2G Ex ia IIC T6..T1 Gb	X	X	X	X	X	X	X	X	X	X	X	X	X	X	X

Certificates: Current version of EX Type examination certificate or Manufactures declaration-ATEX can be found in Danfoss Productstore.

Note: Valve / refrigerant marked with (X) indicate that the valve is compatible with the refrigerant, but a standard valve with Chloroprene O-rings can also be used

ANNEX III - Manufacturer's declaration for potentially explosive atmospheres

DocuSign Envelope ID: F640D5C7-3F73-41E7-995C-0AD15184F828

ENGINEERING
TOMORROW



MANUFACTURER'S DECLARATION
Danfoss A/S
Industrial Refrigeration

Danfoss A/S

6430 Nordborg

Denmark

CVR nr.: 20 16 57 15

Telephone: +45 7488 2222

Fax: +45 7449 0949

declares under our sole responsibility that the product(s) covered by this declaration is in conformity with the following directive(s), standard(s) or other normative document(s), provided that the product is used in accordance with our instructions.



The manufacturer's declaration is valid for all below listed products and the released refrigerants for the actual product acc. to Danfoss Product Store or Coolselector2

A	Stop Valves	SVA-S/L, SVA-SS, SVA-DH/DL, SNV
A	Filters FIA	FIA, FIA-SS, FIA 65B, FIA 140B
A	Check Valves	NRVS
A	Check Valves	NRVA
A	Pilot valve housing welded	CVH

B	Regulating Valves - REG	REG, REG-SS
B	Stop Check Valves - SCA	SCA, SCA-SS
B	Check Valves - CHV	CHV, CHV-SS
B	Overflow valves - OFV	OFV, OFV-SS
B	Float Valves	HFI
B	Float Valves	SV
B	Pilots for ICS Valves	CVP-L/M/H, CVPP-L/M/H, CVC-L/M/H
B	Safety Valves	SFA, SFA-H
B	Safety Valves	SFV
B	Safety Valves	BSV
B	Change Over Valves for Safety Valves	DSV
B	Safety Valves	POV

Valves which can be mounted with electrically pilots / equipment

C	Main Valves (control valves)	ICS 1, ICS 3, ICLX
C	Main Valves (control valves)	PMC
C	Pilots for ICS Valves	EVM
C	Electrically operated expansion valve	AKVA
C	Solenoid Valves	EVRS, EVRST
C	Solenoid Valves	EVRA, EVRAT

Date: 2023.01.11 Place of issue: DK6430 Nordborg	DocuSigned by:  Niels P. Vestergaard C2FA56398FA94EC... Name: Name: Niels Vestergaard Title: Global Application Expert	Date: 2023.01.11 Place of issue: DK6430 Nordborg	Approved by DocuSigned by:  Jesper Kirkegaard 02CE1A82330744A... Signature: Name: Name: Jesper Kirkegaard Title: Director Engineering
---	---	---	--

Danfoss only vouches for the correctness of the English version of this document. In the event of the document being translated into any other language, the translator concerned must be liable for the correctness of the translation.

DocuSign Envelope ID: F640D5C7-3F73-41E7-995C-0AD15184F828

ENGINEERING
TOMORROW

Valves with special O-rings compatible with the specified refrigerants (Propylene) released for the actual product

D	Main Valves (control valves)	ICS 3E
D	Pilot float valve	SV3E
D	Pilots for ICS Valves	CVP-HPE
D	Pilots for ICS Valves	CVCE
D	Pilots for ICS Valves	EVME

For the above listed valves, a hazard analysis to the directive ATEX 2014/34/EU has been carried out with the following result:

- This non-electrical equipment holds no potential ignition source in normal rated conditions incl. malfunctions
- The listed valves are **not covered by the scope of ATEX Directive 2014/34/EU**.
- The listed valves can be used in the categories:
 - II 3G, gas groups IIA and IIB (applicable in Zone 2)
 - II 2G, gas groups IIA and IIB (applicable in Zone 1)

Note 1: Valves used for the above condition shall be installed and maintained according to the requirements in EN 378.

Note 2: End user shall avoid electrostatic discharge or make any impact to cause sparks in the application, service, or maintenance.

Note 3: Electronic / Mechanical actuators / pilots used to operate the above-mentioned equipment, has to undergo a separate conformity assessment.

Note 4: Products on this certificate are grouped in the following groups:

- A. Products that are refrigerant neutral
- B. Products that have sealing elements that is dependent on the actual refrigerant
- C. Products that have sealing elements that is dependent on the actual refrigerant and which can be mounted with electrically pilots / equipment
- D. Products that with special O-rings compatible with the specified refrigerants e.g. Propylene. The products may also be mounted with electrically pilots / equipment

Reference to standards and directives:

EN ISO 80079-36:2016

EN 378:2016

Danfoss only vouches for the correctness of the English version of this document. In the event of the document being translated into any other language, the translator concerned must be liable for the correctness of the translation.

ID No: 033F1196
This doc. is managed by
500B0577

Revision No: 01

Page 2 of 2

Always check the latest version of Manufactures Declaration acc. ATEX on Danfoss Product Store.

ANNEX IV
Valves for HC-refrigerants

ICS pilot control		Code no.
ICS3E	20 D-5	027H1060
ICS3E	20 D-10	027H1061
ICS3E	20 D-15	027H1062
ICS3E	20 D-20	027H1063
ICS3E	20 D-25	027H1064
ICS3E	25 D-5	027H2175
ICS3E	25 D-10	027H2176
ICS3E	25 D-15	027H2177
ICS3E	25 D-20	027H2178
ICS3E	25 D-25	027H2179
ICS3E	32 D	027H3029
ICS3E	40 D	027H4038
ICS3E	50 D	027H5037
ICS3E	65 D	027H6038

SV3E Pilot float valve		Code no.
SV3E		027B0081

CVPE Pressure control pilot		Code no.
CVPE-M	4 to 28 bar	027B1021
CVPE-L	-0,66 to 7 bar	027B1020

CVCE Pressure control pilot		Code no.
CVCE	-0,66 to 7 bar	027B1040

EVME Solenoid pilot		Code no.
EVME		032F8029

ANNEX V
ICS3E valves

- Are servo operated valves which belong to the ICV (Industrial Control Valve) family
- Are special valves which can be used with Hydro Carbon refrigerants
- Have three pilot pressure connections

Max. working pressure: 65 bar (943 psig).

O-ring material: Fluorocarbon (Viton) compound for low temperature application.

Marking: The valve is marked with the name "ICS3E".

Technical data

Refrigerants: Selected HC, Propane R290, Propylene R1270, Ethane R170, Butane R600, Iso-Butane R600a.

All dimensions and performance data are identical to the standard ICS (Literature no.: [AI241186442033](#)).

Temperature range: -40 °C to 120 °C (-40 °F to 248 °F).

Material specification

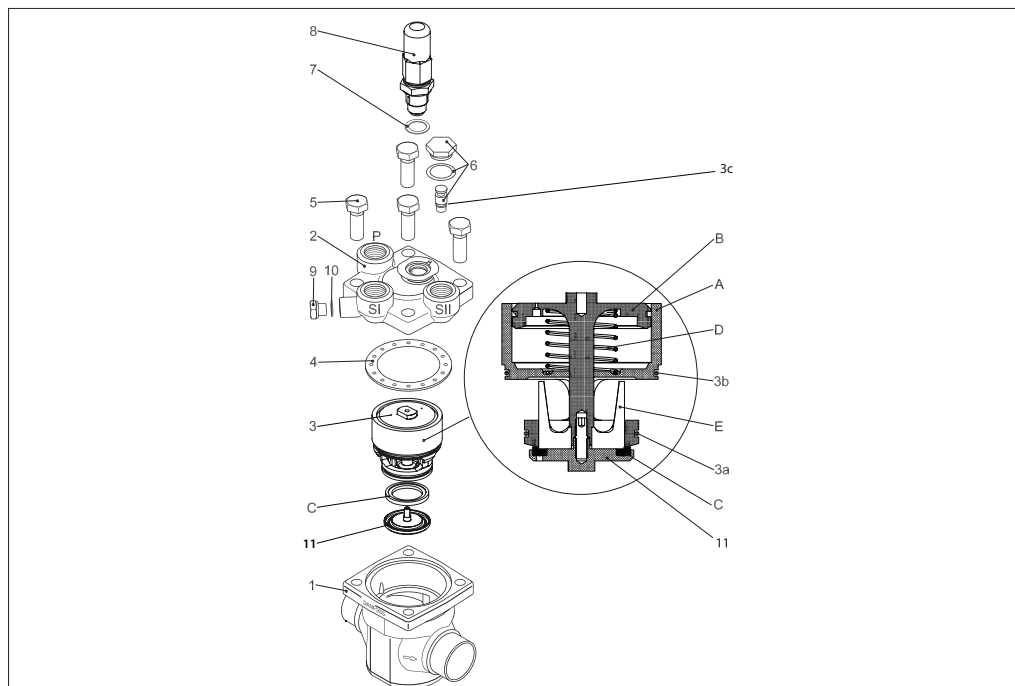

No.	Part	Material	EN	ASTM	JIS
1	Body	Low temperature steel	G20Mn5QT, EN 10213-3	LCC A352	SCPL1 G5151
2	Top cover	Low temperature steel	G20Mn5QT, EN 10213-3 P285QH+QT 10222-4	LCC A352 LF2, A350	SCPL1 G5151
3	Function module (assembled)				
3a	O-ring	Fluorocarbon (Viton)			
3b	O-ring	Fluorocarbon (Viton)			
3c	o-ring	Fluorocarbon (Viton)			
A	Cylinder	Steel			
B	Piston	Steel			
C	Valve plate	PTFE			
D	Spring	Steel			
E	Cone	Steel			
4	Gasket	Fibre, non-asbestos			
5	Bolts	Stainless steel	A2-70, EN 1515-1	Grade B8 A320	A2-70, B 1054
6	Plug	Steel			
7	Gasket	Aluminium			
8	Manual operating spindle	Steel			
9	Plug	Steel			
10	Gasket	Aluminium			
11	Washer plate	Steel			

SV3E valves

- Can be used separately as a modulating liquid level regulator in refrigerating, freezing and air conditioning systems for ammonia or fluorinated refrigerants.
- Are special valves which can be used with Hydro Carbon refrigerants

Max. working pressure: 28 bar (406 psig).

O-ring material: Fluorocarbon (Viton) compound for low temperature application.

Marking: The valve is marked with the name "SV3E".

Technical data

Refrigerants: Selected HC, Propane R290, Propylene R1270, Ethane R170, Butane R600, Iso-Butane R600a.

All dimensions and performance data are identical to the standard SV (Literature no: [AI175286419654](#)).

Temperature range: -40 °C to 120 °C (-40 °F to 248 °F).

Material specification

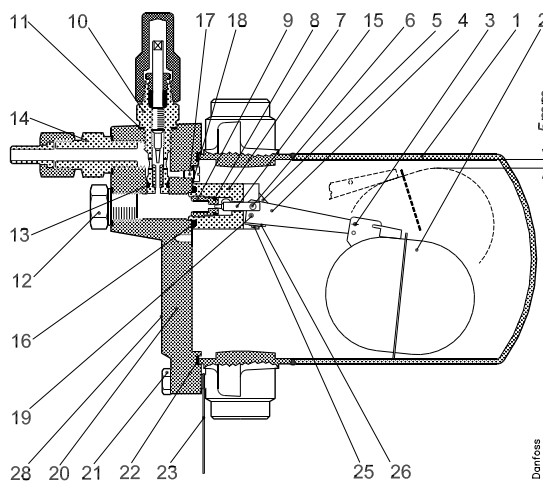

No.	Part	Material	DIN / EN
1	Float housing	Stainless steel Low temperature, steel	X5CrNi18-10, DIN 17440 P285QH, EN 10222-4
2	Float	Stainless steel	
3	Split pin	Steel	
4	Float arm	Stainless steel	
5	Link	Steel	
6	Pin	High density polymer	
7	Valve housing	Steel	
8	O-ring	Fluorocarbon (Viton)	
9	Float orifice	High density polymer	
10	Manual regulation unit. Throttle valve	Steel	
11	Gasket	Non asbestos	
12	Plug	Steel	
13	O-ring	Fluorocarbon (Viton)	
14	Pilot connection (spare part)	Steel	
15	Orifice needle	Plastic	
16	O-ring	Fluorocarbon (Viton)	
17	Screw	Steel	
18	Gasket	Non asbestos	
19	Pin	Steel	
20	Cover	Low temperature, cast iron (spherical)	EN-GJS-400-18-LT EN 1563
21	Screw	Stainless steel	A2-70
22	Gasket	Non asbestos	
23	Label	Cardboard	
25	Screw	Steel	
26	Spring washer	Steel	
28	Sign	Aluminium	

CVPE valves

- Are constant pressure pilot valves for high pressure applications
- Are special valves which can be used with Hydro Carbon refrigerants

Technical data

Refrigerants:

Selected HC, Propane R290, Propylene R1270, Ethane R170, Butane R600, Iso-Butane R600a.

Temperature range: -40 °C to 120 °C (-40 °F to 248 °F).

Max. working pressure: 65 bar (943 psig).

O-ring material:

Fluorocarbon (Viton) compound for low temperature application.

Marking:

The valve is marked with the name "CVPE".

All dimensions and performance data are identical to the standard CVP (Literature no.: [AI248786497190](#)).

Material specification

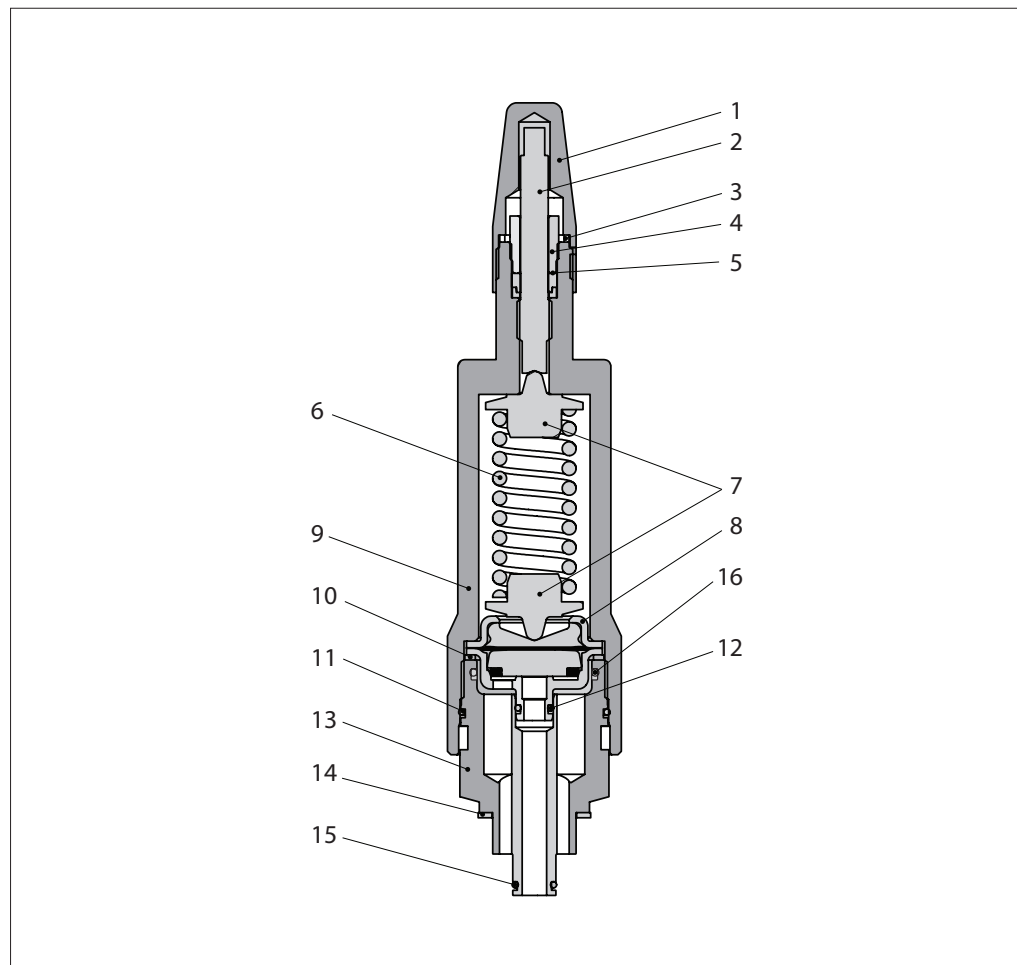

No.	Part	Material
1	Protective cap	Steel
2	Setting spindle	Stainless steel
3	Cap seal	Nylon
4	Packing gland	Steel
5	Seal	Teflon
6	Spring	Steel
7	Spring plate	Steel
8	Diaphragm assembly	Stainless steel
9	Valve bonnet	Steel
10	Cover seal	Alu
11	Back up O-ring	CR
12	O-ring	Fluorocarbon (Viton)
13	Base part	Steel
14	Seal	Fiber gasket
15	O-ring	Fluorocarbon (Viton)
16	O-ring	Fluorocarbon (Viton)

CVCE valves

- Are pressure-operated pilot valves with an external signal connection that can be used to obtain an indication of the system reference pressure
- Are special valves which can be used with Hydro Carbon refrigerants

Temperature range: -40 °C to 120 °C (-40 °F to 248 °F).

Max. working pressure: 65 bar (943 psig).

O-ring material:

Fluorocarbon (Viton) compound for low temperature application.

Marking:

The valve is marked with the name "CVCE".

All dimensions and performance data are identical to the standard CVC (Literature no.: [AI248786497190](#)).

Technical data

Refrigerants:

Selected HC, Propane R290, Propylene R1270, Ethane R170, Butane R600, Iso-Butane R600a.

Material specification

No.	Part	Material
1	Protective cap	Steel
2	Setting spindle	Stainless steel
3	Cap seal	Nylon
4	Packing gland	Steel
5	Seal	Teflon
6	Spring	Steel
7	Spring plate	Steel
8	Diaphragm assembly	Stainless steel
9	Valve bonnet	Steel
10	Cover seal	Alu
11	Back up O-ring	CR
13	Base part	Steel
14	Seal	Fiber gasket
15	O-ring	Fluorocarbon (Viton)
16	Seal	Fiber gasket
17	Plug for external pressure G¼	Steel
18	Seal	Fiber gasket
19	Banjo	Steel
20	O-ring	Fluorocarbon (Viton)
21	O-ring	Fluorocarbon (Viton)
22	O-ring	Fluorocarbon (Viton)
23	O-ring	Fluorocarbon (Viton)

EVME valves

- Are pilot solenoid valves suitable for liquid, suction and hot gas lines applications
- Are special valves which can be used with Hydro Carbon refrigerants

Technical data

Refrigerants:

Selected HC, Propane R290, Propylene R1270, Ethane R170, Butane R600, Iso-Butane R600a.

Temperature range: -40 °C to 120 °C (-40 °F to 248 °F).

Max. working pressure: 65 bar (943 psig).

O-ring material:

Fluorocarbon (Viton) compound for low temperature application.

Marking:

The valve is marked with the name "EVME".

All dimensions and performance data are identical to the standard EVM (Literature no.: [AI248786497190](#)).

Note: Solenoid coils must be EX approved.

Material specification

No.	Part	Material
2	Armature	Stainless steel
3	Armature tube	Stainless steel
4	Seal	Non-asbestos
5	O-ring	Fluorocarbon (Viton)
6	Seal	Aluminium
7	Spacing ring	CR
10	Valve body	Steel
11	Valve seat	Teflon (PTFE)

Danfoss A/S

Climate Solutions • danfoss.com • +45 7488 2222

Any information, including, but not limited to information on selection of product, its application or use, product design, weight, dimensions, capacity or any other technical data in product manuals, catalogues descriptions, advertisements, etc. and whether made available in writing, orally, electronically, online or via download, shall be considered informative, and is only binding if and to the extent, explicit reference is made in a quotation or order confirmation. Danfoss cannot accept any responsibility for possible errors in catalogues, brochures, videos and other material. Danfoss reserves the right to alter its products without notice. This also applies to products ordered but not delivered provided that such alterations can be made without changes to form, fit or function of the product.

All trademarks in this material are property of Danfoss A/S or Danfoss group companies. Danfoss and the Danfoss logo are trademarks of Danfoss A/S. All rights reserved.