



# Accumulators

**Bladder, Diaphragm & Piston Type**

**Sizes to 454 l (120 USgal.)**

**Pressures to 345 bar (5000 psi)**



# Table of Contents

---

ApplicationBenefits .....	5
Introduction.....	6
Technical Support .....	7
Bladder Accumulators .....	8
BottomRepairable ModelCode .....	9
Bottom Repairable InstallationDimensions .....	10
Top Repairable Model Code / InstallationDimensions .....	11
High Flow Model Code / InstallationDimensions .....	12
Transfer Barrier Model Code / InstallationDimensions .....	13
Gas Bottle Model Code / InstallationDimensions .....	14
Surge Arrestor Model Code / InstallationDimensions .....	15
Hydracushion Accumulator.....	16
Diaphragm Accumulator.....	17
Piston Accumulator.....	20
Accessories .....	21
ApplicationData .....	23
Data Sheet .....	25

# The Vickers Advantage

---

**Vickers** understands the need to improve machine performance, efficiency and reliability with cost effective hydraulic systems. Vickers accumulators help to achieve these goals while contributing to lower energy costs, reduced noise levels and a reduction in hydraulic system leakage and maintenance costs.

**Vickers** offers bladder, piston and diaphragm type accumulators in a wide range of sizes, bladder materials, port configurations and pressure ratings to provide optimum design flexibility. There is also the assurance that the materials used in construction and manufacturing are controlled to exacting specifications and backed by Vickers no-nonsense warranty.

**Manufacturing** is conducted in a plant which is approved and monitored by various national and state agencies. For example, the plant is authorized to use the American Society of Mechanical Engineers (ASME) "U" Code to certify that the accumulator meets all requirements of the ASME Boiler and Pressure Vessel Code, Section VIII, Division 1. Other codes are also available upon request. A quality control system which meets the U.S. Government's MIL-I-45208A ensures consistent superior product quality on time, every time.

## **Vickers accumulators offer customers the following advantages:**

### **Lower System Installed Costs**

Accumulator assisted hydraulics can reduce the size of the pump and electric motor which results in a smaller amount of oil used, a smaller reservoir and reduced cooling capacity

### **Reduced Energy Costs**

Cost savings up to 33% are achievable in high performance industrial machinery using accumulators.

### **Less Leakage & Maintenance Costs**

The ability to reduce system shocks will prolong component life, reduce leakage from pipe joints and minimize hydraulic system maintenance costs.

### **Improved Performance**

Low inertia accumulators can provide instantaneous response time to meet peak flow requirements. They can also help to achieve constant pressure in systems using variable displacement pumps for improved productivity and quality.

### **Reduced Noise Levels**

Reduced pump and motor size coupled with system shock absorption lowers overall machine sound levels and results in higher operator productivity.

### **Flexible Design Approaches**

A wide range of accumulator types and sizes, including accessory items, provides a versatile and easy to apply design approach.

In addition to the standard products described in this catalog, Vickers has the capability to provide special accumulator shells, bladders and fluid ports to meet specific customer specifications. Special coatings can also be provided to resist corrosive working fluids. Please contact your local distributor or Vickers representative to discuss your requirements.

# Basic Models & Features

Type	Model	Features
<b>Bottom Repairable</b>	A2**	<ul style="list-style-type: none"> <li>• Nine sizes from 0,16 l to 57 l (10 in<sup>3</sup> to 15 USgal.)</li> <li>• 210 bar (3000 psi) and 345 bar (5000 psi) ratings</li> <li>• Wide range of bladder materials</li> <li>• Interchangeable with units produced by others</li> </ul>
<b>Top Repairable</b>	A3**	<ul style="list-style-type: none"> <li>• Can be serviced from both ends</li> <li>• 210 bar (3000 psi) and 345 bar (5000 psi) ratings</li> <li>• Wide range of bladder materials</li> <li>• Cannot be disassembled under pressure</li> </ul>
<b>High Flow</b>	A4**	<ul style="list-style-type: none"> <li>• Up to 3372 l/min (600 USgpm) flow rate</li> <li>• Five sizes rated at 210 bar (3000 psi)</li> <li>• Meets 4:1 safety requirements</li> <li>• Wide range of bladder materials</li> </ul>
<b>Transfer Barrier</b>	A5**	<ul style="list-style-type: none"> <li>• 210 bar (3000 psi) and 345 bar (5000 psi) ratings</li> <li>• Integral pressure relief</li> <li>• Straight thread or SAE split flange ports</li> <li>• Available for oil, water or chemical service</li> </ul>
<b>Gas Bottles</b>	A6**	<ul style="list-style-type: none"> <li>• Meets 4:1 safety requirements</li> <li>• Cannot be disassembled under pressure</li> <li>• Seven sizes up to 57 l (15 USgal)</li> <li>• Variety of port options are available</li> </ul>
<b>Surge Arrestors</b>	A7**	<ul style="list-style-type: none"> <li>• Eight sizes from 9,5 l to 454 l (2.5 to 120 USgal)</li> <li>• 19 bar to 35 bar (275 or 500 psi) ratings</li> <li>• Available for oil, water or chemical service</li> <li>• Operates over a wide temperature range</li> </ul>
<b>Hydracushion</b>	A8**	<ul style="list-style-type: none"> <li>• Non-repairable, economic design</li> <li>• Compact, lightweight construction</li> <li>• Units are rated at 138 bar (2000 psi)</li> <li>• Four sizes from 0,5 l to 3,8 l (30 in<sup>3</sup> to 230 in<sup>3</sup>)</li> </ul>
<b>Diaphragm</b>	A9**	<ul style="list-style-type: none"> <li>• Lightweight, compact design</li> <li>• Meets 4:1 safety requirements</li> <li>• Nine sizes to 3,5 l (215 in<sup>3</sup>)</li> <li>• Working pressures to 210 bar (3000 psi)</li> </ul>
<b>Piston</b>	AP**	<ul style="list-style-type: none"> <li>• 13 sizes from 0,95 l to 38 l (1 qt to 10 USgal)</li> <li>• Units are rated at 210 bar (3000 psi)</li> <li>• Meets 4:1 safety requirements</li> <li>• Compact and simple design provides long life</li> </ul>

# Application Benefits

## 1. Reduction of installed power.

Using an accumulator as an energy storage device effectively reduces the required flow rate capacity of the hydraulic pump. This results in a reduction of the installed power.

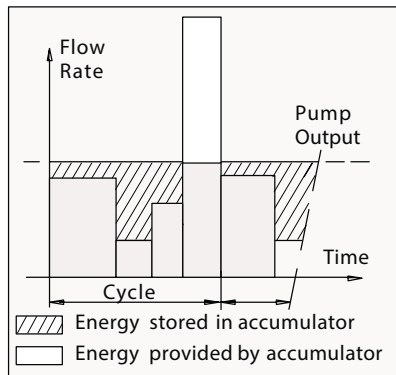

1.

## 2. Emergency and safety.

An accumulator which is kept constantly under pressure allows for instant and/or repetitive operations as required (braking, opening of door, etc.).

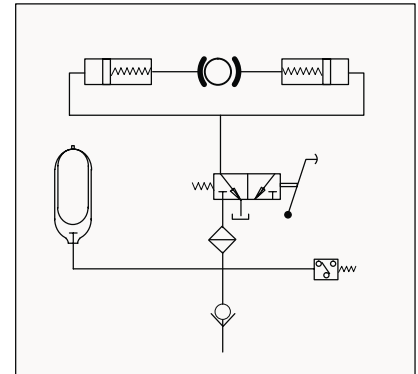

2.

## 3. Dampening of pulsation and reduction of noise

In order to dampen pressure changes, which are caused by the pulsation of a pump, an accumulator makes it possible, due to the low inertia of its bladder, to improve the precision of operation and to reduce the sound level of the installation.

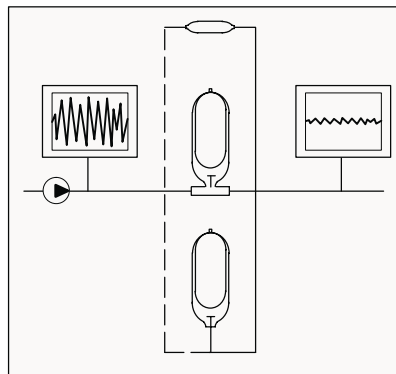

3.

## 4. Thermal expansion.

The pressure differences caused by thermal variation in a closed hydraulic circuit are absorbed by fitting an accumulator.

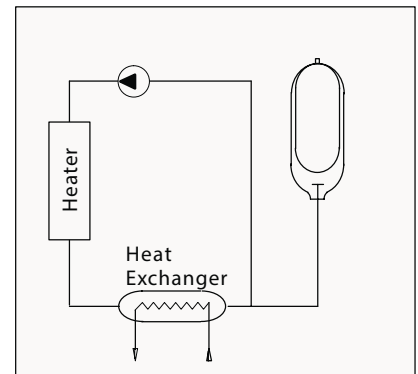

4.

## 5. Surge control.

Designed to protect high volume flow systems from surge and water hammer damage. In order to protect the system, an accumulator correctly sized and located in the system transforms pressure wave oscillations into liquid mass oscillations which are easily absorbed by the accumulator, bringing the pressure peak level back to acceptable levels.

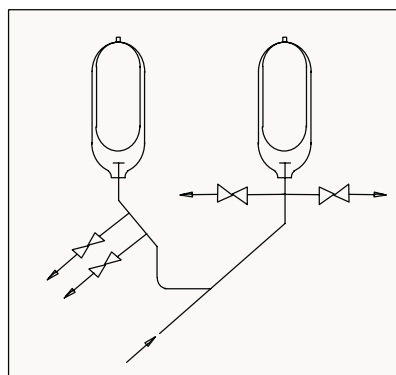

5.

## 6. Suspension of heavy vehicles.

On maintenance machinery, transport platforms etc., an accumulator which is connected to the suspension chamber acts as an adjustable shock absorber.

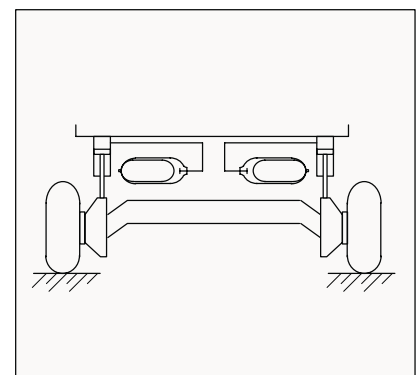

6.

# Introduction

## General description

The shells of bladder and piston type accumulators are manufactured from a homogeneous, seamless tubing. In bladder accumulators one or both ends is formed hemispherically by either spinning or hammering operations. Strict heat treatment and stress relieving is performed on all shells after the forging operation to ensure compliance with the required mechanical properties.

A full range of bladders have been developed from the most advanced elastomers capable of meeting low temperatures (down to -45°F) and high temperatures (up to 400°F). These same bladder materials are compatible with most fluids.

A computer program enables calculation of the gas permeation level of different elastomers. This allows us to recommend a bladder material and set up a pre-charge maintenance program which is suited to our customers needs.

The fluid port incorporates a poppet valve which prevents the extrusion of the bladder. Special care has been taken in the design of the fluid port assembly to prevent turbulent flow, pressure drop, and potential preclosure of the poppet valve. A heavy duty spring prevents premature closure of the poppet valve.

The design of the bladder accumulator makes use of the considerable difference in compressibility between a gas and fluid. The bladder contained in the shell is precharged with nitrogen gas to a pressure determined by the work to be done.

After precharging, the bladder occupies the whole of the volume of the shell. From there the working can be split into three stages.

**Stage 1:** When the hydraulic pump in the system causes the fluid to enter the accumulator, the nitrogen contained in the bladder compresses and its pressure is increased.

**Stage 2:** The deformation of the bladder ceases when the pressure of the fluid and the nitrogen become balanced. During this stage the bladder is not subject to any abnormal mechanical stress and due to its design deforms sideways forming three lobes.

**Stage 3:** On demand, system pressure falls and the stored fluid is returned to the system under pressure exerted by the compressed nitrogen. On completion of the hydraulic system functions, the accumulator returns to stage 1.

## Bladder Materials

The following bladder materials are readily available. Buna-N bladders and seals are standard and are suitable for most fluid power applications. Other materials are offered to provide compatibility with a wide range of fluids, working temperatures and permeation requirements. Please consult your Vickers representative when special requirements are encountered.

### Bladder Materials

- BN - Buna-N (nitrile)
- VT - Fluorocarbon (viton)
- BL - Butyl
- EP - Ethylene Propylene
- CW - Special nitrile blend for low temperature applications (-40 °F to 248 °F)
- HL - Hydrin for applications requiring extremely low permeation.

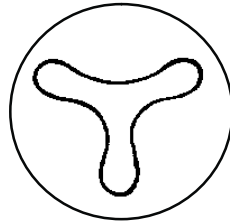

three lobes

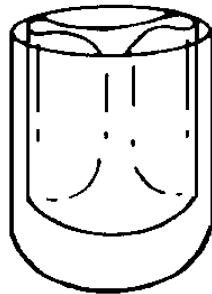

# Technical Support

Whether for a standard fluid power something more exotic, our engineers have the experience and knowledge to assist you in defining the optimum accumulators for your system.

An extensive applications data base and computer aided design enables us to perform stress calculations by finite element analysis. Simulation software integrates all the physical phenomena to optimize accumulator sizing recommendations.

The following is a list of some typical application calculations which are available through this system:

- Fluid Storage
- Pulsation Dampening
- Surge Control
- Suction Stabilizing
- Permeation
- Pressure Drop
- Thermal Expansion
- Noise Attenuation
- High Flow Performance

Please use the Data Sheet at the end of this brochure to provide the necessary information on your application. Product Specification such as system fluid should be identified in Section A. Specific application information should be included in the appropriate section.

## Certifications

Vickers accumulators can be supplied with most pressure vessel certifications:

- Australia - Australian Standards
- Austria, Belgium, Germany - T.U.V.
- France - Service des mines
- Great Britain - British Standards
- Holland - Stoomwezen
- Italy- ISPESEL
- Japan - J.I.S.
- Norway - D.N.V.
- Switzerland- S.V.D.B.
- Sweden - AB Statens
- Canada - CRN for different provinces
- United States - ASME

There will be a price adder for foreign certifications.

## Bladder Accumulator Service Data

Order Service Data - # I-3980-S

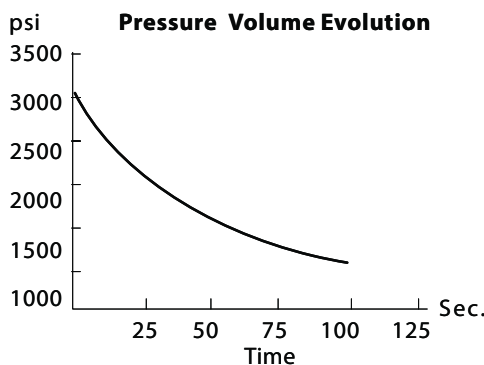
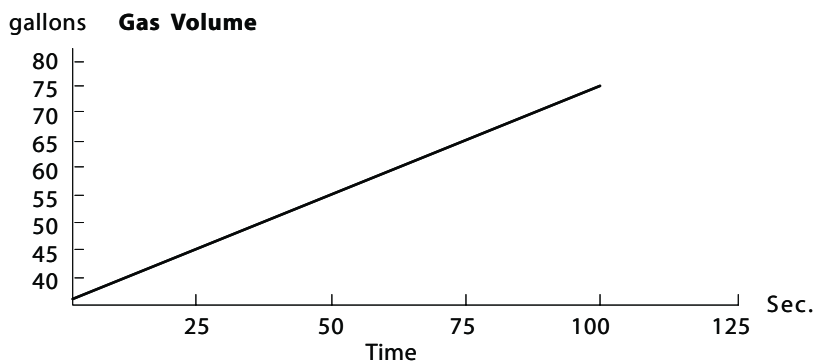
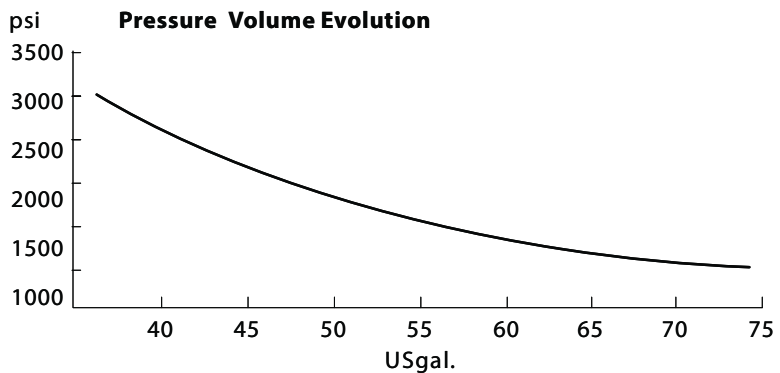
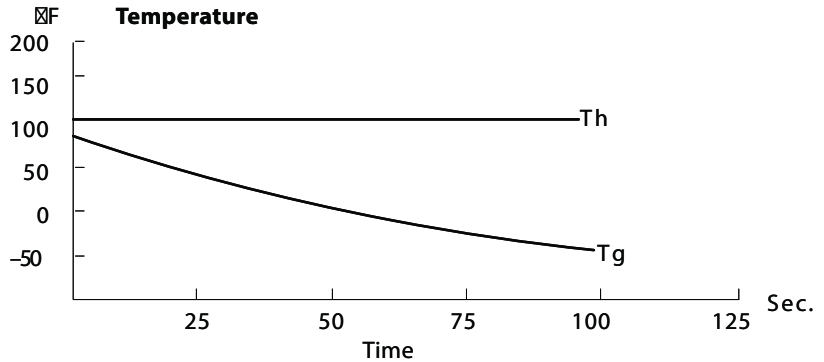

# Bladder Accumulators

## Features and Benefits

- Meets A.S.M.E. specifications with a 4:1 safety factor.
- Also available with foreign certifications.
- Interchangeable with many competitors units.
- Specially formulated bladder compounds provide very low permeability for longer intervals between recharging.
- Top repairable models enable quick and easy service without removal from the manifold or line.

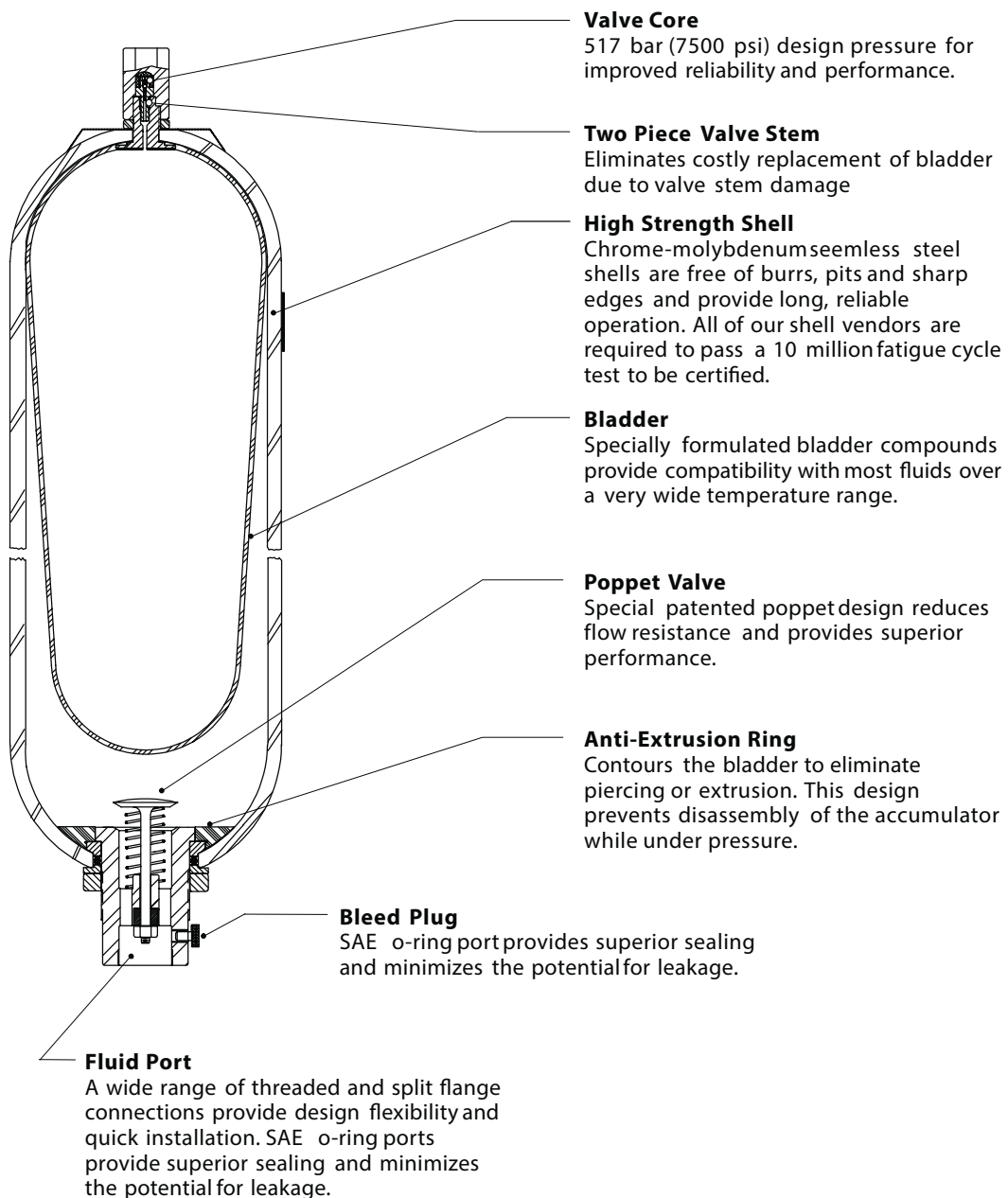

# Bottom Repairable

---

## Model Code

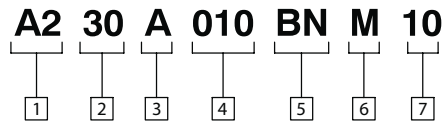

---

### 1 Type

A2 – Standard, bottom repairable

---

### 2 Pressure Rating

30 – 210 bar (3000 psi)  
50 – 345 bar (5000 psi)

---

### 3 Port Configuration

A – 3/4" str. thd.  
B – 1 1/16" str. thd.  
C – 1 5/16" str. thd.  
D – 1 5/8" str. thd.  
E – 1 7/8" str. thd.  
F – 1 1/4" split flange (code 61)  
G – 2" split flange (code 61)  
H – 1 1/2" split flange (code 62)  
P – NPTF pipe thd. (not recommended)

---

### 4 Size

010 – 0,16 l (10 in<sup>3</sup>)  
030 – 0,473 l (1 US pint)  
060 – 0,946 l (1 US quart)  
230 – 3,79 l (1 USgal.)  
578 – 9,46 l (2.5 USgal.)  
05G – 18,9 l (5 USgal.)  
10G – 37,9 l (10 USgal.)  
15G – 56,8 l (15 USgal.)

---

### 5 Bladder Material

BN – Buna-N (std.)  
VT – Viton  
BL – Butyl  
EP – EPR  
CW – Cold weather  
HL – Hydrin

---

### 6 Service

M – Petroleum oil  
W – Water  
S – Stainless steel

---

### 7 Design Number

# Bottom Repairable

## Installation Dimensions

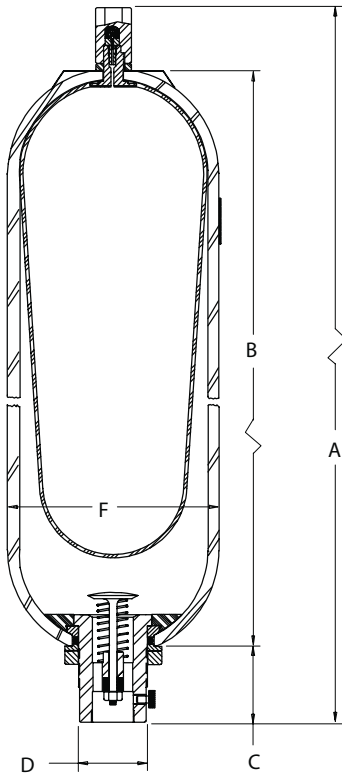

Model	Size	A mm (inches)	B mm (inches)	C mm (inches)	D dia. mm (inches)	E port option (see model code)	F dia. mm (inches)	Weight kg (lbs)
-30	010	295,7 (11.64)	200,7 (7.90)	46,2 (1.82)		A, P	56,1 (2.21)	2,13 (4.7)
	030	247,7 (9.75)	171,5 (6.75)	53,8 (2.12)	38,1 (1.50)	B, P	88,9 (3.50)	3,18 (7)
	060	292,1 (11.5)	193,5 (7.62)	50,8 (2.0)	44,5 (1.75)	C, P	114,3 (4.50)	4,54 (10)
	230	444,5 (17.5)	279,4 (11.0)	85,9 (3.38)	60,5 (2.38)	D, F, P	171,5 (6.75)	15,4 (34)
	578	558,8 (22.0)	406,4 (16.0)	88,9 (3.5)	76,2 (3.0)	E, G, P	230 (9.06)	31,3 (69)
	05G	870 (34.25)	711,2 (28.0)	88,9 (3.5)	76,2 (3.0)	E, G, P	230 (9.06)	54,4 (120)
	10G	1372 (54.0)	1232 (48.5)	88,9 (3.5)	76,2 (3.0)	E, G, P	230 (9.06)	99,8 (220)
	15G	1969 (77.5)	1829 (72.0)	88,9 (3.5)	76,2 (3.0)	E, G, P	230 (9.06)	138 (305)
-50	578	577,9 (22.75)	406,4 (16.0)	88,9 (3.5)	76,2 (3.0)	H, P	242,8 (9.56)	57,2 (126)
	05G	889 (35.0)	717,6 (28.25)	88,9 (3.5)	76,2 (3.0)	H, P	242,8 (9.56)	103 (226)
	10G	1416 (55.75)	1245 (49.0)	88,9 (3.5)	76,2 (3.0)	H, P	242,8 (9.56)	155 (341)
	15G	2013 (79.25)	1842 (72.5)	88,9 (3.5)	76,2 (3.0)	H, P	242,8 (9.56)	223 (491)

Fluid Port Repair Kits	
Model	Part Number
A2 30 C 060 BN	02-316867
A2 30 D 230 BN	02-316868
A2 30 E 578 BN	02-316869
A2 50 E 15G BN	02-316869
Contains port piece, nut, anti extrusion ring and seals	

Seal Kits	
Model	Part Number
A2 30 ** 060 BN	02-316870
A2 30 ** 230 BN	02-316871
A2 30 ** 578 BN	02-316872
A2 50 ** 15G BN	02-316872
Contains anti extrusion ring and seals on port end only.	

Bladders	
Model	Part Number
A2 30 ** 060 BN	02-316860
A2 30 ** 230 BN	02-316861
A2 30 ** 578 BN	02-316862
A2 30 ** 05G BN	02-316863
A2 30 ** 10G BN	02-316864
A2 30 ** 15G BN	02-316865
A2 50 ** 578 BN	02-316866
Contains bladder, gas fill valve, anti extrusion ring and seals.	

# Top Repairable

## Model Code

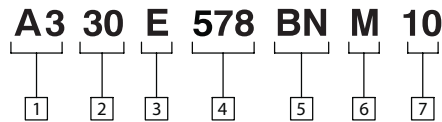

### 1 Type

A3 – Accumulator, top repairable

### 2 Pressure Rating

30 – 210 bar (3000 psi)  
 50 – 345 bar (5000 psi)

### 3 Port Configuration

E – 1 7/8" str. thd.  
 G – 2" split flange (code 61)  
 H – 1 1/2" split flange (code 62)  
 P – NPTF pipe thd. (not recommended)

### 4 Size

578 – 9,46 l (2.5 USgal.)  
 05G – 18,9 l (5 USgal.)  
 10G – 37,9 l (10 USgal.)  
 15G – 56,8 l (15 USgal.)

### 5 Bladder Material

BN – Buna-N (std.)  
 VT – Viton  
 BL – Butyl  
 EP – EPR  
 CW – Cold weather  
 HL – Hydrin

### 6 Service

M – Petroleum oil  
 W – Water  
 S – Stainless steel

### 7 Design Number

## Installation Dimensions

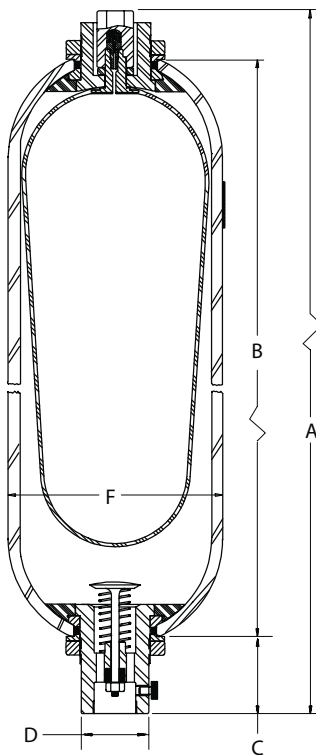

Model	Size	A mm (inches)	B mm (inches)	C mm (inches)	D dia. mm (inches)	E port option (see model code)	F dia. mm (inches)	Weight kg (lbs)
-30	578	533,4 (21.0)	381 (15.0)	88,9 (3.5)	76,2 (3.0)	E, G, P	230 (9.06)	36,3 (80)
	05G	844,6 (33.25)	692,2 (27.25)	88,9 (3.5)	76,2 (3.0)	E, G, P	230 (9.06)	54,4 (120)
	10G	1372 (54.0)	1219 (48.0)	88,9 (3.5)	76,2 (3.0)	E, G, P	230 (9.06)	99,8 (220)
	15G	1969 (77.5)	1816 (71.5)	88,9 (3.5)	76,2 (3.0)	E, G, P	230 (9.06)	138 (305)
-50	578	546 (21.5)	406,4 (16.0)	88,9 (3.5)	76,2 (3.0)	E, H, P	242,8 (9.56)	54,4 (120)
	05G	857 (33.75)	717,6 (28.25)	88,9 (3.5)	76,2 (3.0)	E, H, P	242,8 (9.56)	99,8 (220)
	10G	1384 (54.5)	1245 (49.0)	88,9 (3.5)	76,2 (3.0)	E, H, P	242,8 (9.56)	152 (335)
	15G	1981 (78.0)	1842 (72.5)	88,9 (3.5)	76,2 (3.0)	E, H, P	242,8 (9.56)	220 (485)

#### Fluid Port Repair Kits

Model	Part Number
A3 30 E 578 BN	02-316869
A3 50 E 15G BN	02-316869

#### Seal Kits

Model	Part Number
A3 30 ** 578 BN	02-316872
A3 50 ** 15G BN	02-316872

#### Bladders

Model	Part Number
A3 30 ** 578 BN	02-316862
A3 30 ** 05G BN	02-316863
A3 30 ** 10G BN	02-316864
A3 30 ** 15G BN	02-316865
A3 30 ** 578 BN	02-316866

# High Flow Accumulator

## Model Code

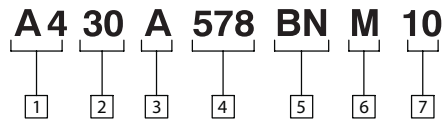

**1 Type**

A4 – Accumulator, high flow

**2 Pressure Rating**

30 – 210 bar (3000 psi)

**3 Port Configuration**

A – 4 1/4" str. thd.  
P – NPTF pipe thd. (not recommended)

**4 Size**

578 – 9,46 l (2.5 USgal.)  
05G – 18,9 l (5 USgal.)  
10G – 37,9 l (10 USgal.)  
15G – 56,8 l (15 USgal.)

**5 Bladder Material**

BN – Buna-N (std.)  
VT – Viton  
BL – Butyl  
EP – EPR  
CW – Cold weather  
HL – Hydrin

**6 Service**

M – Petroleum oil  
W – Water  
S – Stainless steel

**7 Design Number**

## Installation Dimensions

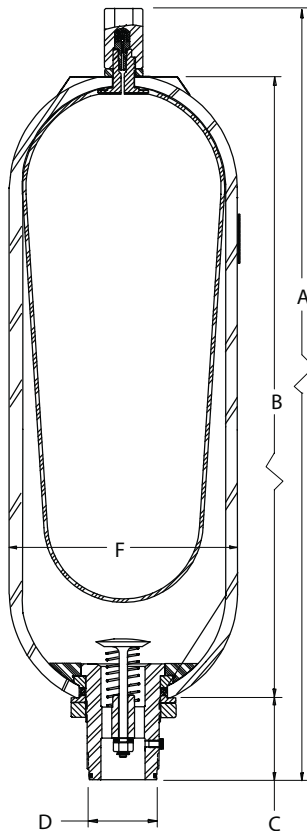

Model	Size	A	B	C	D dia.	E port option (see model code)	F dia.	Weight kg (lbs)
		mm (inches)						
-30	578	571,5 (22.5)	393,7 (15.5)	136,7 (5.38)	101,6 (4.0)	A, P	230 (9.06)	36,3 (80)
	05G	882,7 (34.75)	704,9 (27.75)	136,7 (5.38)	101,6 (4.0)	A, P	230 (9.06)	54,4 (120)
	10G	1409,7 (55.5)	1232 (48.5)	136,7 (5.38)	101,6 (4.0)	A, P	230 (9.06)	99,8 (220)
	15G	2007 (79.0)	1829 (72.0)	136,7 (5.38)	101,6 (4.0)	A, P	230 (9.06)	138 (305)

Fluid Port Repair Kits	
Model	Part Number
A4 30 A 578 BN	02-316874
A4 30 A 15G BN	02-316874

Seal Kits	
Model	Part Number
A4 30 * 578 BN	02-317650
A4 30 * 15G BN	02-317650

Bladders	
Model	Part Number
A4 30 * 578 BN	02-316682
A4 30 * 05G BN	02-316683
A4 30 * 10G BN	02-316684
A4 30 * 15G BN	02-316685

# Transfer Barrier Accumulator

## Model Code

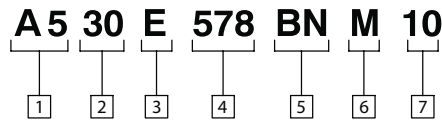

<b>1 Type</b> A5 – Accumulator, transfer barrier	<b>4 Size</b> 578 – 9,46 l (2.5 USgal.) 05G – 18,9 l (5 USgal.) 10G – 37,9 l (10 USgal.) 15G – 56,8 l (15 USgal.)	<b>6 Service</b> M – Petroleum oil W – Water S – Stainless steel
<b>2 Pressure Rating</b> 30 – 210 bar (3000 psi) 50 – 345 bar (5000 psi)	<b>5 Bladder Material</b> BN – Buna-N (std.) VT – Viton BL – Butyl EP – EPR CW – Cold weather HL – Hydrin	<b>7 Design Number</b>
<b>3 Port Configuration</b> E – 1 7/8" str. thd. G – 2" split flange (code 61) H – 1 1/2" split flange (code 62) P – NPTF pipe thd. (not recommended)		

## Installation Dimensions

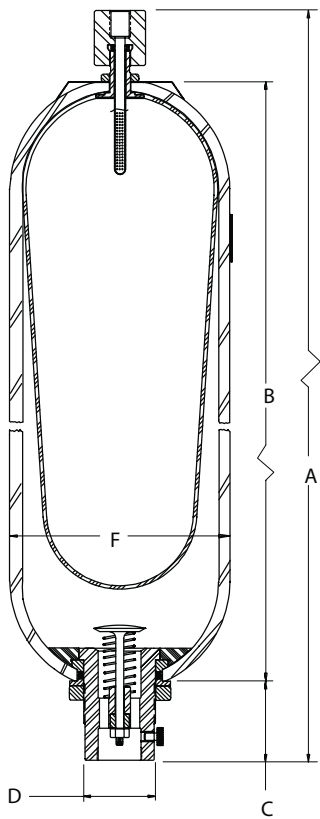

Model	Size	A mm (inches)	B mm (inches)	C mm (inches)	D dia. mm (inches)	E port option (see model code)	F dia. mm (inches)	Weight kg (lbs)
-30	578	533,4 (21.0)	394 (15.5)	88,9 (3.5)	76,2 (3.0)	E, G, H, P	230 (9.06)	31,3 (69)
	05G	838 (33.0)	698,5 (27.5)	88,9 (3.5)	76,2 (3.0)	E, G, H, P	230 (9.06)	54,4 (120)
	10G	1372 (54.0)	1232 (48.5)	88,9 (3.5)	76,2 (3.0)	E, G, H, P	230 (9.06)	99,8 (220)
	15G	1969 (77.5)	1816 (72.0)	88,9 (3.5)	76,2 (3.0)	E, G, H, P	230 (9.06)	138 (305)
-50	578	552 (21.75)	394 (15.5)	88,9 (3.5)	76,2 (3.0)	E, H, G, P	242,8 (9.56)	57,2 (126)
	05G	857 (33.75)	699 (27.5)	88,9 (3.5)	76,2 (3.0)	E, H, G, P	242,8 (9.56)	103 (226)
	10G	1391 (54.75)	1232 (48.5)	88,9 (3.5)	76,2 (3.0)	E, H, G, P	242,8 (9.56)	155 (341)
	15G	1988 (78.25)	1829 (72.0)	88,9 (3.5)	76,2 (3.0)	E, H, G, P	242,8 (9.56)	223 (491)

Fluid Port Repair Kits	
Model	Part Number
A5 30 E 578 BN	02-316869
A5 50 E 15G BN	02-316869

Bladders	
Model	Part Number
A5 30 * 578 BN	02-317651
A5 30 * 05G BN	02-317652
A5 30 * 10G BN	02-317653
A5 30 * 15G BN	02-317654
A5 50 * 578 BN	02-317655

Seal Kits	
Model	Part Number
A5 30 * 578 BN	02-316872
A5 50 * 15G BN	02-316872

# Gas Bottle

## Model Code

**A6 30 E 060 M 10**

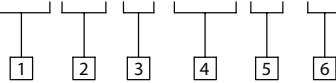

### 1 Type

A6 – Gas bottle

### 2 Pressure Rating

30 – 210 bar (3000 psi)  
50 – 345 bar (5000 psi)

### 3 Port Configuration

C – 1 5/16" str. thd.  
D – 1 5/8" str. thd.  
E – 1 7/8" str. thd.  
G – 2" split flange (code 61)  
H – 1 1/2" split flange (code 62)  
P – NPTF pipe thd. (not recommended)

### 4 Size

060 – 0,946 l (1 US quart)  
230 – 3,79 l (1 USgal.)  
578 – 9,46 l (2.5 USgal.)  
05G – 18,9 l (5 USgal.)  
10G – 37,9 l (10 USgal.)  
15G – 56,8 l (15 USgal.)

### 5 Service

M – Petroleum oil  
W – Water  
S – Stainless steel

### 6 Design Number

## Installation Dimensions

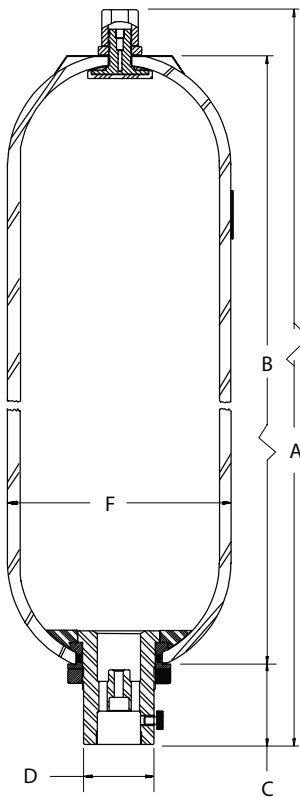

Model	Size	A B		C	D	E	F	Weight
		mm (inches)			dia.	port option (see model code)	dia.	kg (lbs)
-30	060	292,1 (11.5)	193,5 (7.62)	50,8 (2.0)	44,5 (1.75)	C, P	114,3 (4.50)	4,08 (9)
	230	444,5 (17.5)	279,4 (11.0)	85,9 (3.38)	60,5 (2.38)	D, P	171,5 (6.75)	14,5 (32)
	578	543 (21.38)	394 (15.5)	92 (3.62)	76,2 (3.0)	E, G, P	230 (9.06)	36,3 (80)
	05G	854 (33.62)	705 (27.75)	92 (3.62)	76,2 (3.0)	E, G, P	230 (9.06)	54,4 (120)
	10G	1381 (54.38)	1232 (48.5)	92 (3.62)	76,2 (3.0)	E, G, P	230 (9.06)	99,8 (220)
	15G	1978 (77.88)	1829 (72.0)	92 (3.62)	76,2 (3.0)	E, G, P	230 (9.06)	138 (305)
-50	578	577,9 (22.75)	406,4 (16.0)	92 (3.62)	76,2 (3.0)	H, P	242,8 (9.56)	57,2 (126)
	05G	889 (35.0)	717,6 (28.25)	92 (3.62)	76,2 (3.0)	H, P	242,8 (9.56)	103 (226)
	10G	1416 (55.75)	1245 (49.0)	92 (3.62)	76,2 (3.0)	H, P	242,8 (9.56)	155 (341)
	15G	2013 (79.25)	1842 (72.5)	92 (3.62)	76,2 (3.0)	H, P	242,8 (9.56)	223 (491)

### Seal Kits

Model	Part Number
A6 30 * 060 BN	02-316870
A6 30 * 230 BN	02-316871
A6 30 * 578 BN	02-316872
A6 50 * 15G BN	02-316872

# Surge Arrestor

## Model Code

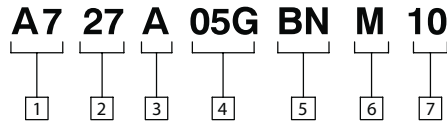

### 1 Type

A7 – Surge Arrestor

### 2 Operating Pressure

27 – 19 bar (275 psi)  
 50 – 34 bar (500 psi)

### 3 Port Configuration

A – 3" 150# ANSI Flange  
 B – 4" 300# ANSI Flange

### 4 Size

578 – 9,46 l (2.5 USgal.)  
 05G – 18,9 l (5 USgal.)  
 10G – 37,9 l (10 USgal.)  
 25G – 94,6 l (25 USgal.)  
 40G – 151 l (40 USgal.)  
 80G – 303 l (80 USgal.)  
 100G – 378,5 l (100 USgal.)  
 120G – 454 l (120 USgal.)

### 5 Bladder Material

BN – Buna-N (std.)  
 VT – Viton  
 BL – Butyl  
 EP – EPR  
 CW – Cold weather  
 HL – Hydrin

### 6 Service

M – Petroleum oil  
 W – Water  
 S – Stainless steel

### 7 Design Number

## Installation Dimensions

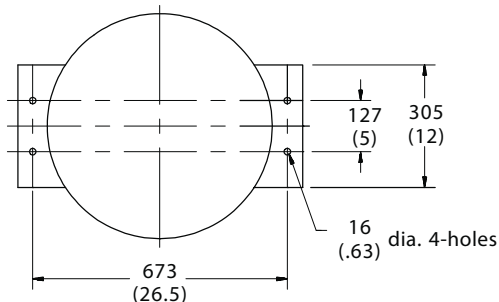
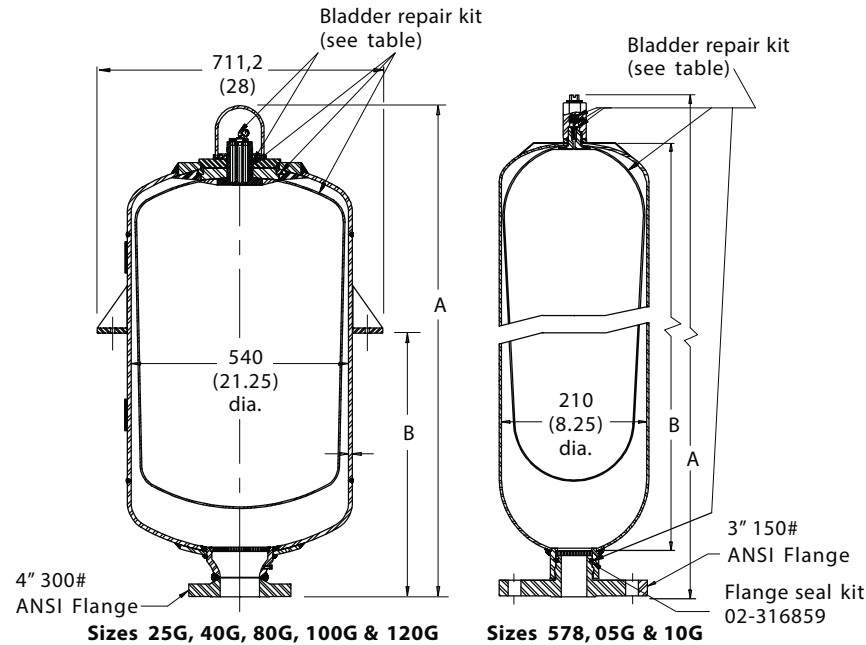

Model	Size	A B		Weight kg (lbs)
		mm (inches)		
27-A-	578	429 (16.88)	318 (12.5)	13,6 (30)
	05G	734 (28.88)	622 (24.5)	19,1 (42)
	10G	1292 (50.88)	1175 (46.25)	30,8 (68)
50-B-	25G	914,4 (36)	431,8 (17.0)	140,6 (310)
	40G	1118 (44)	546,1 (21.5)	167 (368)
	80G	1676 (66)	927,1 (36.5)	295 (650)
	100G	2159 (85)	927,1 (36.5)	397 (875)
	120G	2616 (103)	1257 (49.9)	453,6 (1000)

### Bladders

Model	Part Number
A 578 BN	02-316851
A 05G BN	02-316852
A 10G BN	02-316853
B 25G BN	02-316854
B 40G BN	02-316855
B 80G BN	02-316856
B 100G BN	02-316857
B 120G BN	02-316858

# Hydracushion Accumulators

The hydracushion is a non-repairable accumulator which has been specially designed for high quantity, economical applications where it is more practical to replace the unit rather than have it refurbished.

## Hydracushion accumulator – 138 bar (2000 psi)

### Special features

- Compact, lightweight, simple construction

- Permanently sealed for maintenance-free operation
- Quick, easy installation and replacement
- Long service life

### Applications

- Agriculture equipment
- Braking systems
- Construction equipment
- Controlling “float” on long boom vehicles

- Car wash systems
- Fuel lines
- Fail-safe hydraulic systems
- Lift trucks
- Machine tools
- Railway equipment
- Steering
- Tensioning
- Tripping and resetting plows, tillers
- Water systems

## Model Code

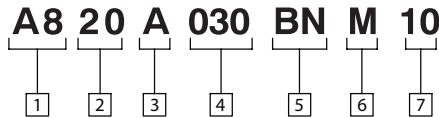

### 1 Type

A8 – Accumulator, hydracushion

### 2 Pressure Rating

20 – 138 bar (2000 psi)

### 3 Port Configuration

A – 3/4" str. thd.  
 B – 1 5/16" str. thd.  
 P – NPTF pipe thd. (not recommended)

### 4 Size

030 – 0,473 l (1 US pint)  
 060 – 0,946 l (1 US quart)  
 120 – 1,892 l (2 quart)  
 230 – 3,79 l (1 US gal.)

### 5 Bladder Material

BN – Buna-N (std.)

### 6 Service

M – Petroleum oil

### 7 Design Number

## Installation Dimensions

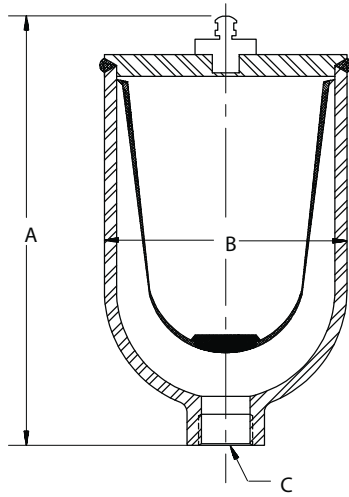

Size	A mm (inches)	B mm (inches)	C port option (see model code)	Weight kg (lbs)
030	216 (8.50)	95 (3.75)	A, P	3,18 (7)
060	260 (10.25)	117 (4.62)	A, P	6,4 (14)
120	319 (12.56)	146 (5.75)	B, P	660 (26)
230	383 (15.06)	178 (7.0)	B, P	1245 (49)

# Diaphragm Accumulators

## Features and Benefits

- Meets A.S.M.E. specifications with a 4:1 safety factor.
- Can be mounted in any position.
- Compression ratios of up to 8:1 attainable on standard models.  
(Compression ratio = Working pressure/Precharge pressure)
- Specially formulated diaphragm compound with very low permeability for longer intervals between recharging.

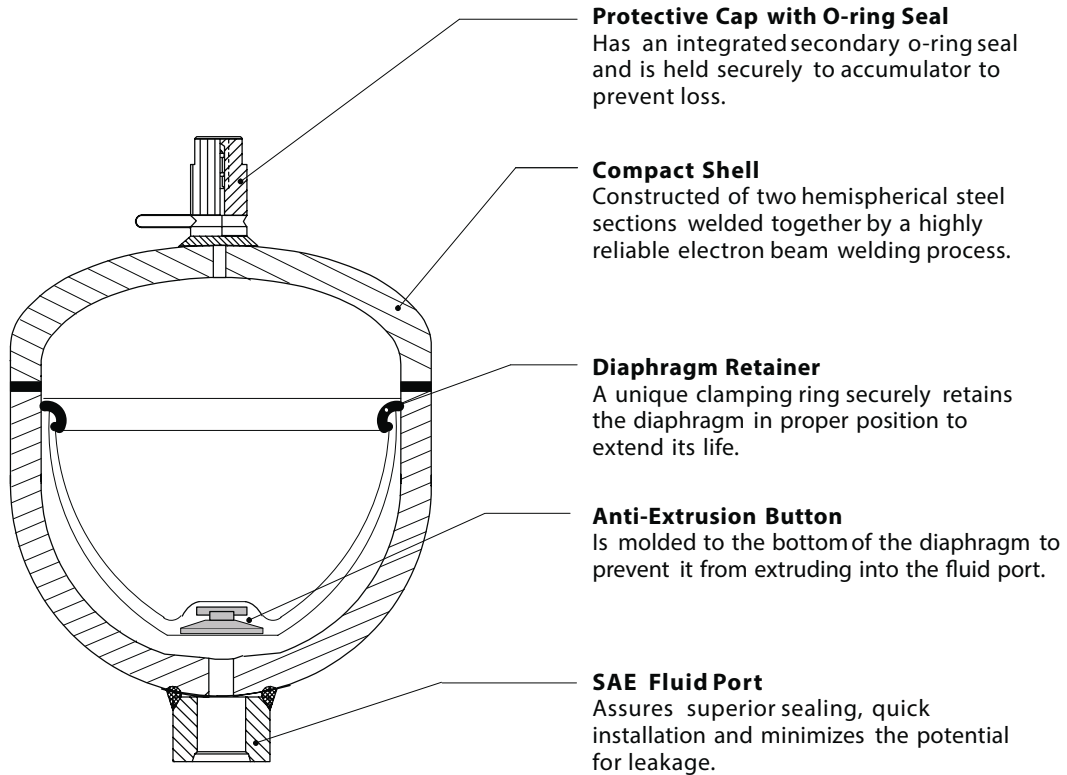

# Diaphragm Accumulators

## Model Code

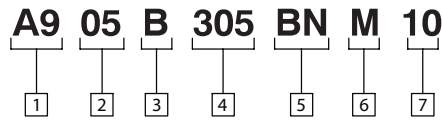

<p><b>1 Type</b> A9 – Accumulator, diaphragm type</p> <hr/> <p><b>2 Pressure Rating</b> 20 – 138 bar (2000 psi) 23 – 159 bar (2300 psi) 30 – 210 bar (3000 psi)</p> <hr/> <p><b>3 Port Configuration</b> A – 9/16" str. thd. B – 3/4" str. thd.</p>	<p><b>4 Size</b> 005 – 0,08 l (5 in<sup>3</sup>) 020 – 0,32 l (20 in<sup>3</sup>) 030 – 0,5 l (30 in<sup>3</sup>) 045 – 0,73 l (45 in<sup>3</sup>) 60 – 0,98 l (60 in<sup>3</sup>) 85 – 1,4 l (85 in<sup>3</sup>) 215 – 3,5 l (215 in<sup>3</sup>)</p> <hr/> <p><b>5 Bladder Material</b> BN – Buna-N (std.)</p>	<p><b>6 Service</b> M – Petroleum oil</p> <hr/> <p><b>7 Design Number</b></p>
---	--	---

## Installation Dimensions

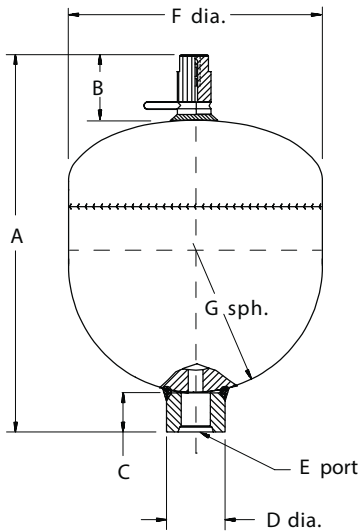

Model	Size	A	B	C	D dia.	E port option (see model code)	F dia.	G	Weight kg (lbs)
		mm (inches)							
-20	060	187 (7.36)	34,8 (1.37)	16 (.63)	37,8 (1.49)	B	136 (5.35)	66 (2.6)	196 (7.7)
-23	030	155 (6.1)	34,8 (1.37)	16 (.63)	37,8 (1.49)	B	106 (4.17)	52,8 (2.08)	1,6 (3.5)
-30	005	119,4 (4.70)	34,5 (1.36)	16 (.63)	27,9 (1.1)	A	127,3 (5.01)	63,5 (2.5)	0,70 (1.54)
	045	179 (7.1)	34,5 (1.37)	16 (.63)	37,8 (1.49)	B	127 (5.0)	63,5 (2.5)	3,5 (7.8)
	085	205 (8.07)	34,8 (1.37)	16 (.63)	37,8 (1.49)	B	175 (6.9)	77,5 (3.05)	6 (13.2)
	215	315 (12.4)	34,8 (1.37)	16 (.63)	37,8 (1.49)	B	175 (6.9)	87,6 (3.45)	10,6 (23.3)

# Piston Accumulators

## Features and Benefits

- Meets A.S.M.E. specifications with a 4:1 safety factor\*.
- Can be mounted in vertical or horizontal positions.
- Compact design provides maximum efficiency, performance and life.
- Applications include energy storage, thermal expansion, shock absorption and transfer barrier.

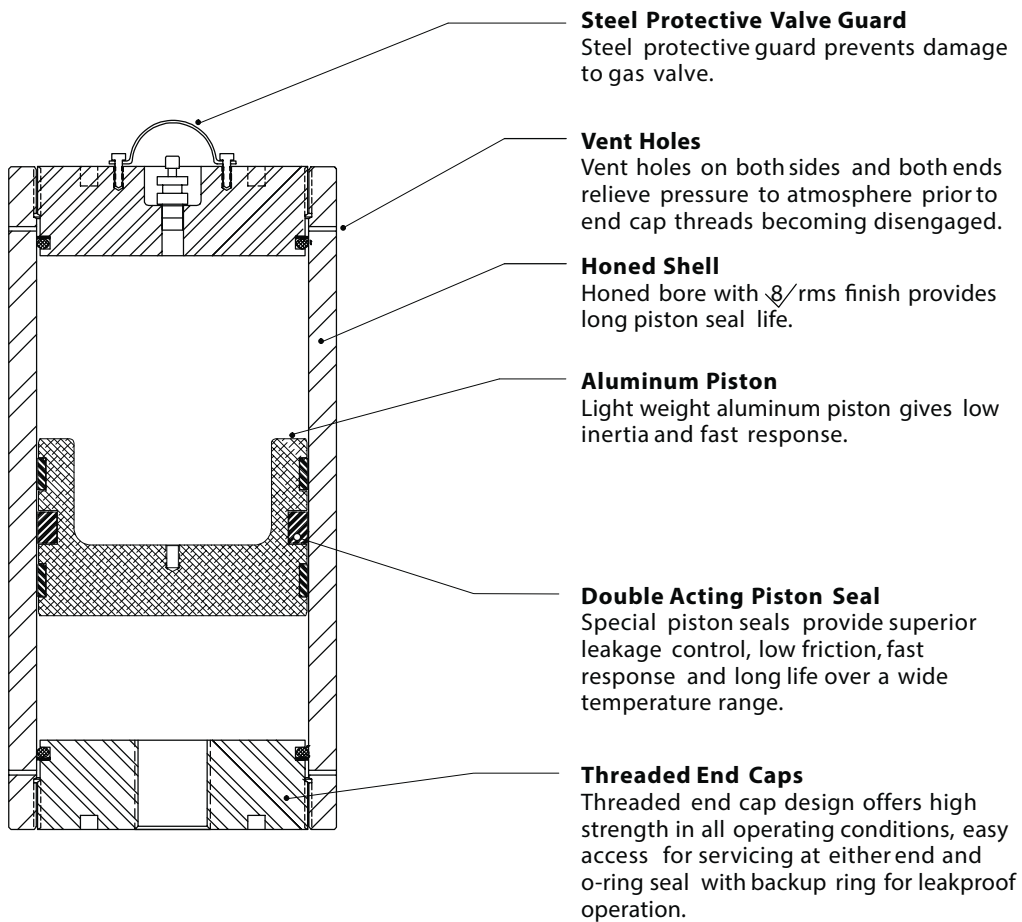

\* Does not carry ASME "U" stamp.

# Piston Accumulators

## Model Code

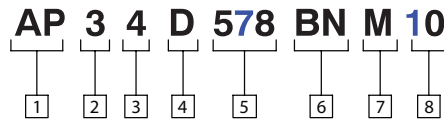

<b>1 Type</b> AP – Piston Accumulator	<b>5 Size</b> 058 – 0,95 l (.25 USgal.) 115 – 1,89 l (.50 USgal.) 230 – 3,79 l (1.0 USgal.) 346 – 5,7 l (1.5 USgal.) 460 – 7,6 l (2.0 USgal.) 578 – 9,46 l (2.5 USgal.) 05G – 18,9 l (5 USgal.) 075G – 28,4 l (7.5 USgal.) 10G – 37,9 l (10 USgal.)	<b>6 Seal Material</b> BN – Buna-N (std.) VT – Viton EP – EPR
<b>2 Pressure Rating</b> 3 – 210 bar (3000 psi)		<b>7 Service</b> M – Petroleum oil W – Water S – Stainless steel
<b>3 Bore Diameter</b> 4 – 4.00" diameter 6 – 5.50" diameter		<b>8 Design Number</b>
<b>4 Port Configuration</b> D – 1 5/8" - 12 straight thread		

## Installation Dimensions

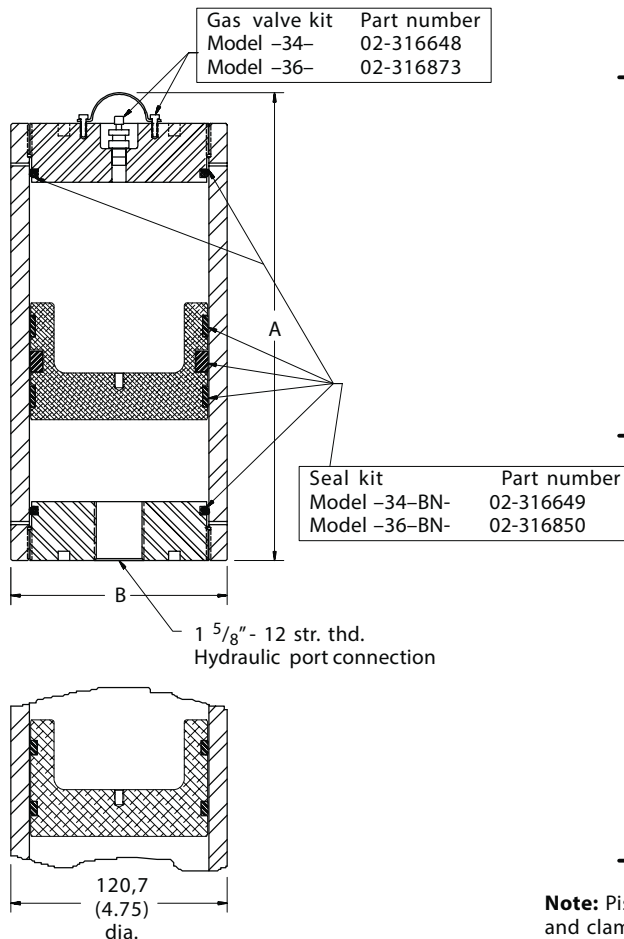

Model	Size	A mm (inches)	B dia. mm (inches)	Weight kg (lbs)
-34-	058	267 (10.5)	121 (4.75)	11,3 (25)
	115	394 (15.5)		16 (35)
	230	648 (25.5)		20,4 (45)
	346	902 (35.5)		25 (55)
	460	1156 (45.5)		31 (68)
	578	1397 (55.0)		36,3 (80)
-36-	230	464 (18.25)	171,4 (6.75)	32 (70)
	346	578 (22.75)		41 (90)
	460	692 (27.25)		54,4 (120)
	578	800 (31.5)		61,2 (135)
	05G	1359 (53.5)		95,3 (210)
	075G	1930 (76.0)		132 (290)
	10G	2540 (100.0)		168 (370)

**Note:** Piston accumulator should be securely supported by brackets and clamps on **end caps only**. Unrestricted piston movement is critical.

# Accessories

---

- Can be used with all types of accumulators (bladder, piston, diaphragm).
- Secure design provides independent mounting on installations.
- Galvanized to resist corrosion.
- Rubber insert provided to reduce mechanical vibration, and to compensate for shell manufacturing tolerances.
- Use one bracket for sizes 1 qt. thru 2.5 USgal. and two brackets for sizes 10 thru 15 USgal.
- Use one saddle for sizes 2.5 USgal. and up.
- Use mounting brackets and saddles for vertical installations only.

## Tool Kits & Part Numbers

Complete tool kit part number (1qt. - 15 USgal. 3000 psi) – 02-317656

Complete tool kit part number, top repairable (2.5 USgal - 15 USgal. 3000 psi) – 02-317657

Complete tool kit part number, standard & top repairable (2.5 USgal - 15 USgal. 5000 psi) – 02-317658

Face spanner wrench (for piston type accumulators only) – 02-317659

Note: Each tool kit includes valve core tool, charging and gauging assembly, spanner wrench and pull rods.

## Accumulator Maintenance Tools

### Bladder pull rods

(Bladder type accumulator) Pull rods are available in different lengths for different size accumulators. The pull rods attach to the gas valve of the bladder for ease of assembly into shell during reassembly.

### Spanner wrench

Fits all standard size bladder accumulators. Used to remove or install lock nut on fluid port assembly.



Part Number 02-317659

### Core repair tool

The core repair tool is used to remove and reinstall the valve core. It is also used to chase gas valve threads.

### Core tool

Can be used to remove and reinstall the valve core.

# Accessories

## Structural Supports

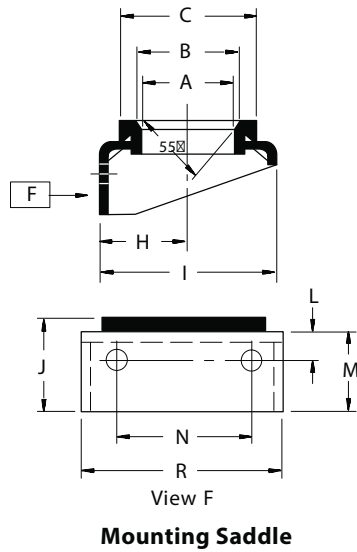

## Mounting Brackets

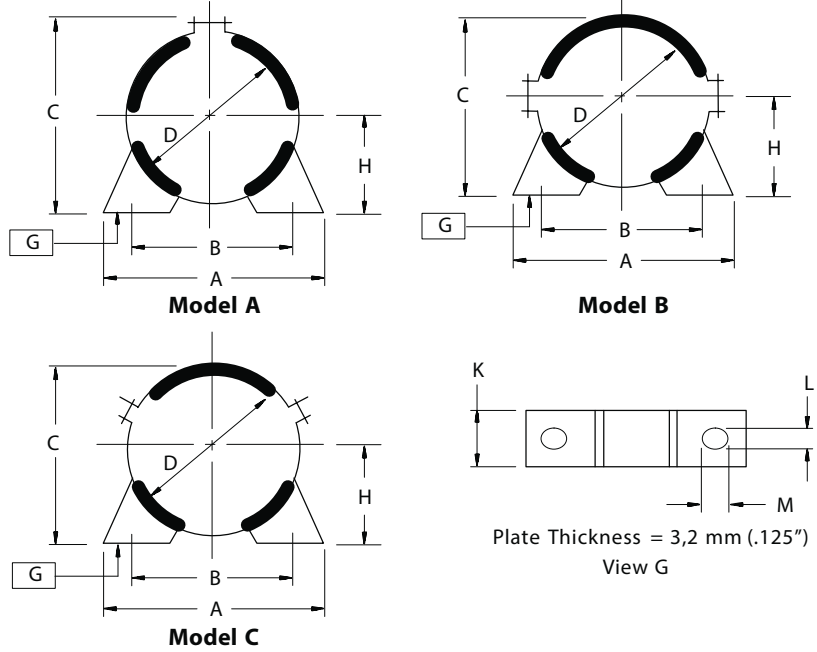

## Bracket dimensions

Part No.	Model	A		B		C		
		In.	cm.	In.	cm.	In.	cm.	
02-317660	1 Qt. bladder & 4.75" dia. piston	A*	5.43	13.8	3.93	10.0	6.75	17.1
02-317661	1 Gal. bladder & 6.75" dia. piston	B	7.40	18.8	5.78	14.7	7.12	18.1
02-317662	2-1/2 to 15 Gal. bladder 3000 psi	B	10.62	27.0	8.50	21.6	9.48	24.1
02-317663	2-1/2 to 15 Gal. bladder 5000 psi	C	11.90	30.2	9.80	24.9	10.27	26.1

D		E		H		K		L		M	
In.	cm.	In.	cm.	In.	cm.	In.	cm.	In.	cm.	In.	cm.
4.58	11.9	-	-	3.07	7.8	1.18	3.0	.35	.90	.55	1.4
6.61	16.8	9.43	23.9	3.62	9.2	1.57	4.0	.35	.90	.55	1.4
8.89	22.6	11.75	29.8	4.82	12.2	1.57	4.0	.35	1.5	.83	2.1
9.65	24.5	13.00	33.0	5.23	13.3	1.63	4.14	.35	1.5	.83	2.1

## Saddle dimensions (including rubber ring seat)

Part No.	A		B		C		H		I		J	
	In.	cm.	In.	cm.	In.	cm.	In.	cm.	In.	cm.	In.	cm.
02-317664	6.25	15.9	6.62	16.8	7.9	20.0	4.9	11.9	9.2	23.4	4.6	11.7
02-317665	6.25	15.9	6.69	17.0	7.9	20.0	5.23	13.3	9.2	23.4	4.6	11.7

K		L		M		N		R		Weight	
In.	cm.	In.	cm.	In.	cm.	In.	cm.	In.	cm.	lb.	Kg
.66	1.6	1.0	2.5	4.0	10.1	7.9	20.0	10.2	26.0	3.2	1.4
.66	1.6	1.	2.5	4.0	10.1	7.9	20.0	10.2	26.0	3.4	1.5

**NOTE:** All dimensions are for general information only.

\* Also used with piston accumulators.

\*\* 02-317662 is used for 2.5 - 15 gal 3000 psi

02-317663 is used for 2.5 -15 gal 5000 psi

# Application Data

## Fluid Cleanliness

Proper fluid condition is essential for long and satisfactory life of hydraulic components and systems. Hydraulic fluid must have the correct balance of cleanliness, materials, and additives for protection against wear of components, elevated viscosity, and inclusion of air.

Essential information on the correct methods for treating hydraulic fluid is included in Vickers publication 561 "Vickers Guide to Systemic Contamination Control" available from your local Vickers distributor or by

contacting Vickers, Incorporated. Recommendations on filtration and the selection of products to control fluid condition are included in 561.

Recommended cleanliness levels, using petroleum oil under common conditions, are based on the highest fluid pressure levels in the system and are coded in the chart below. Fluids other than petroleum, severe service cycles, or temperature extremes are cause for adjustment of these cleanliness codes. See Vickers publication 561 for exact details.

Vickers products, as any components, will operate with apparent satisfaction in fluids with higher cleanliness codes than those described. Other manufacturers will often recommend levels above those specified. Experience has shown, however, that life of any hydraulic component is shortened in fluids with higher cleanliness codes than those listed below. These codes have been proven to provide a long, trouble-free service life for the products shown, regardless of the manufacturer.

Product	System Pressure Level bar (psi)		
	<70 ( <1000)	70-207 (1000-3000)	207+ ( 3000+)
Accumulators	20/18/15	19/17/14	18/16/13
Vane Pumps –Fixed	20/18/15	19/17/14	18/16/13
Vane Pumps –Variable	18/16/14	17/15/13	
Piston Pumps –Fixed	19/17/15	18/16/14	17/15/13
Piston Pumps –Variable	18/16/14	17/15/13	16/14/12
Directional Valves	20/18/15	20/18/15	19/17/14
Pressure/Flow Control Valves	19/17/14	19/17/14	19/17/14
CMX Valves	18/16/14	18/16/14	17/15/13
Servo Valves	16/14/11	16/14/11	15/13/10
Proportional Valves	17/15/12	17/15/12	15/13/11
Cylinders	20/18/15	20/18/15	20/18/15
Vane Motors	20/18/15	19/17/14	18/16/13
Axial Piston Motors	19/17/14	18/16/13	17/15/12
Radial Piston Motors	20/18/14	19/17/13	18/16/13

# Data Sheet

**Please read carefully and complete Section A plus the appropriate application section. By doing this you will allow us to propose the best possible solution to enhance your system performance. We suggest you photocopy this form and FAX it to us.**

Company Name \_\_\_\_\_ Name \_\_\_\_\_  
Address \_\_\_\_\_ City \_\_\_\_\_ State & Zip \_\_\_\_\_  
Telephone \_\_\_\_\_ FAX \_\_\_\_\_

## A. Product Specifications:

Internal Coating ..... \_\_\_\_\_  
External Coating ..... \_\_\_\_\_  
Shell Material ..... \_\_\_\_\_  
Bladder Material ..... \_\_\_\_\_  
Design Approval ..... \_\_\_\_\_  
Installation Location (City, Country) ..... \_\_\_\_\_  
System Fluid ..... \_\_\_\_\_  
Maximum Working Temp. .... °C (°F) \_\_\_\_\_  
Minimum Working Temp. .... °C (°F) \_\_\_\_\_  
Maximum Working Pressure ..... bar (psi) \_\_\_\_\_  
Minimum Working Pressure ..... bar (psi) \_\_\_\_\_  
Fluid Port Connection ..... \_\_\_\_\_

## B. Applications:

### 1. Energy Storage:

Volume of Fluid Needed ..... l (USgal) \_\_\_\_\_  
Dual Time (Charge-Discharge) ..... (sec.) \_\_\_\_\_  
Maximum Ambient Temperature ..... °C (°F) \_\_\_\_\_  
Minimum Ambient Temperature ..... °C (°F) \_\_\_\_\_  
Work Cycle Profile (number of stages, time & pressure) ..... (Enclose drawing or graph)  
Minimum Working Pressure ..... bar (psi) \_\_\_\_\_  
Maximum Working Pressure ..... bar (psi) \_\_\_\_\_

### 2. Pulsation Dampening:

Flow Rate ..... l/min (USgpm) \_\_\_\_\_  
Type of Pump (Piston, Vane, Gear, etc.) ..... \_\_\_\_\_  
Number of Elements (Pistons, Vanes, Gears, etc.) ..... \_\_\_\_\_  
Pump Speed ..... (rpm) \_\_\_\_\_  
Working Temperature ..... °C (°F) \_\_\_\_\_  
Working Pressure ..... bar (psi) \_\_\_\_\_  
Pressure Peaks (high and low) ..... bar (psi) \_\_\_\_\_  
Nominal Pipe Size ..... (inches) \_\_\_\_\_  
Maximum Allowable Pressure Drop ..... bar (psi) \_\_\_\_\_  
Minimum Allowable Working Pressure ..... bar (psi) \_\_\_\_\_

# Data Sheet

---

### 3. Suction Stabilizing:

Flow Rate ..... l/min(USgpm) \_\_\_\_\_

Type of Pump (Piston, Vane, Gear, etc.) ..... \_\_\_\_\_

Number of Elements (Pistons, Vanes, Gears, etc.) ..... \_\_\_\_\_

Pump Speed ..... (rpm) \_\_\_\_\_

Working Temperature ..... °C (°F) \_\_\_\_\_

Working Pressure ..... bar (psi) \_\_\_\_\_

Nominal Pipe Size ..... (inches) \_\_\_\_\_

Minimum Allowable Working Pressure ..... bar (psi) \_\_\_\_\_

If possible (applicable to both sections 2 & 3):

Minimum Pump Frequency ..... (Hz) \_\_\_\_\_

Maximum Pump Frequency ..... (Hz) \_\_\_\_\_

The band width which the accumulator is attenuating above 20 db ..... \_\_\_\_\_

### 4. Surge Dampening:

Valve Opening\* ..... \_\_\_\_\_

Time of operation ..... (sec.) \_\_\_\_\_

Valve Closing\* (If possible enclose a schematic of valve closure sequence.) ..... \_\_\_\_\_

Pump Start-up Time ..... (sec.)\* \_\_\_\_\_

Pump Shut-off Time ..... (sec.)\* \_\_\_\_\_

(If possible enclose a schematic of pump start-up/shut-off sequence.)

Pipe Characteristics:

Nominal Internal Diameter ..... (inches) \_\_\_\_\_

Pipe Thickness ..... (inches) \_\_\_\_\_

Pipe Length ..... (feet) \_\_\_\_\_

Pipe Material ..... \_\_\_\_\_

Maximum Allowable Pressure for Pipe ..... bar (psi) \_\_\_\_\_

Hydraulic Characteristics:

Pressure at the Pump\*/Valve ..... bar (psi) \_\_\_\_\_

At max. flow rate ..... bar (psi) \_\_\_\_\_

At zero flow rate ..... bar (psi) \_\_\_\_\_

Flow Rate ..... l/min(USgpm) \_\_\_\_\_

Max. Allowable Working Pressure ..... bar (psi) \_\_\_\_\_

Min. Allowable Working Pressure (supply schematic of system piping) ..... bar (psi) \_\_\_\_\_

\* Delete when not applicable.

### 5. Thermal Expansion:

Total System Volume ..... l (USgal.) \_\_\_\_\_

System Fluid ..... \_\_\_\_\_

Fluid Thermal Expansion Coefficient ..... \_\_\_\_\_

**Products we offer:**

- Cartridge valves
- DCV directional control valves
- Electric converters
- Electric machines
- Electric motors
- Gear motors
- Gear pumps
- Hydraulic integrated circuits (HICs)
- Hydrostatic motors
- Hydrostatic pumps
- Orbital motors
- PLUS+1<sup>®</sup> controllers
- PLUS+1<sup>®</sup> displays
- PLUS+1<sup>®</sup> joysticks and pedals
- PLUS+1<sup>®</sup> operator interfaces
- PLUS+1<sup>®</sup> sensors
- PLUS+1<sup>®</sup> software
- PLUS+1<sup>®</sup> software services, support and training
- Position controls and sensors
- PVG proportional valves
- Steering components and systems
- Telematics

**Danfoss Power Solutions** is a global manufacturer and supplier of high-quality hydraulic and electric components. We specialize in providing state-of-the-art technology and solutions that excel in the harsh operating conditions of the mobile off-highway market as well as the marine sector. Building on our extensive applications expertise, we work closely with you to ensure exceptional performance for a broad range of applications. We help you and other customers around the world speed up system development, reduce costs and bring vehicles and vessels to market faster.

Danfoss Power Solutions – your strongest partner in mobile hydraulics and mobile electrification.

**Go to [www.danfoss.com](http://www.danfoss.com) for further product information.**

We offer you expert worldwide support for ensuring the best possible solutions for outstanding performance. And with an extensive network of Global Service Partners, we also provide you with comprehensive global service for all of our components.

Local address:

**Hydro-Gear**

[www.hydro-gear.com](http://www.hydro-gear.com)

**Daikin-Sauer-Danfoss**

[www.daikin-sauer-danfoss.com](http://www.daikin-sauer-danfoss.com)

**Danfoss Power Solutions (US) Company**  
2800 East 13th Street  
Ames, IA 50010, USA  
Phone: +1 515 239 6000

**Danfoss Power Solutions GmbH & Co. OHG**  
Krokamp 35  
D-24539 Neumünster, Germany  
Phone: +49 4321 871 0

**Danfoss Power Solutions ApS**  
Nordborgvej 81  
DK-6430 Nordborg, Denmark  
Phone: +45 7488 2222

**Danfoss Power Solutions Trading (Shanghai) Co., Ltd.**  
Building #22, No. 1000 Jin Hai Rd  
Jin Qiao, Pudong New District  
Shanghai, China 201206  
Phone: +86 21 2080 6201