

Data sheet.

## 2/2-way Directional Control Valves

VDH

For inline mounting and Cetop 3 flange mounting (ISO 4401)

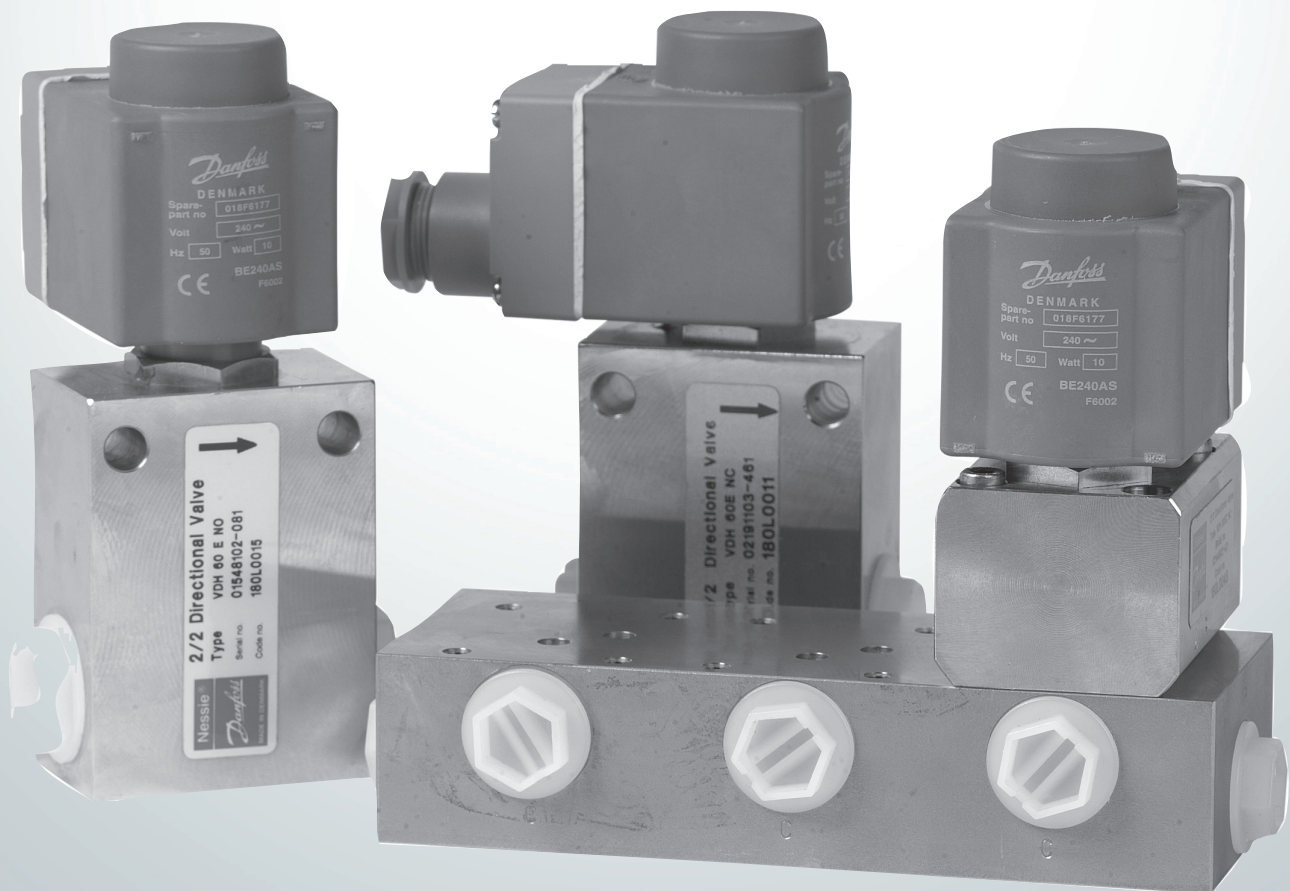

**1. Introduction**

The VDH directional control valves are designed for applications with tap water, i.e. without additives (EU-Directive 98/83/EC).

The directional valves are used to control water flow direction.

**Function**

The directional valves are pilot operated On/Off 2/2-way seat valves electrically activated by 1 coil.

**Features**

- Corrosion resistant surfaces
- Easy to clean surfaces
- The seat valve design ensures zero leakage
- High degree of protection, IP 67
- Cetop valve installable on all cetop 3 blocks

**Filtration**

The water supplied to the valve must be filtered: 10 µm absolute, β<sub>10</sub>-value > 5000 filter is recommended.

For further information on filters, please contact the Danfoss sales department for High Pressure Pumps.

**Versions**

**Inline versions:**

- VDH 30 E 2/2
- VDH 60E 2/2
- VDH 120 E 2/2

**Cetop 3 block version:**

- VDH 30 EC 2/2

The valve housing comes in standard version in stainless steel AISI 304 (W.no. 1.4301).

The valve is available as a normally closed valve (NC) or as a normally open valve (NO).

On request the valve housing is obtainable in stainless steel AISI 316L (W.no. 1.4401), please contact the Danfoss Sales Organization for High Pressure Pumps.

**If the recommendations in the manual are not followed, Danfoss reserves the right to void the warranty.**

**2. VDH valve selection overview**

E	Straight flow direction
EC	Cetop 3 manifolde

**Temperature**

*Operation on (clean) water:*

Fluid temperature and ambient temperature: 3 °C – 50 °C.

*Operation on water containing antifreeze:*

Fluid temperature and ambient temperature: -30 °C – 50 °C<sup>1)</sup>.

*Storage temperature:*

-40 °C – 70 °C

provided that the valve is drained of fluid and stored "plugged".

**Antifreeze protection<sup>1)</sup>**

If a system requires antifreeze protection, Danfoss recommends Dowcall N or Chillsafe mono propylene glycol from the Dow Chemical Company and Arco Chemical Company, respectively.

Both antifreezes are biologically degradable and must be used together with demineralized water. Mixing ratio must be:

- Min. 30% antifreeze and 70% demineralize water providing frost protection to -13 °C and preventing biofilm in the system.
- Max. 50% antifreeze and 50% demineralize water due to increased viscosity, providing frost protection to -30 °C.

**3. Code numbers and technical data**
**2/2-way directional control valves, type VDH 30 E**

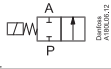
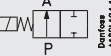

Pressure loss at max. flow: 6 barg (87 psig)  
 Max. opening/closing time: 150 ms/350 ms  
 Leakage at pressure higher than 10 barg (145 psig): 0 ml/min (0 GPM) drip proof  
 Degree of protection: IP 67

Type	Function symbol	Code number	Con- nection	Max. inlet pressure cont. barg (psig)	Max inlet pressure peak barg (psig)	Operation pressure <sup>1)</sup> barg (psig)	Max. flow l/min (GPM)	Min. flow l/min (GPM)	Weight incl. coil kg (lb)
VDH 30 E 2/2 NC	 Danfoss A180L0002	180L0002	G 3/8 "	140 (2.030)	200 (2,900)	3.5 (50.7)	30 (7.9)	1 (0.3)	1.6 (3.8)
VDH 30 E 2/2 NO	 Danfoss A180L0003	180L0003	G 3/8 "	140 (2.030)	170 (2,465)	3.5 (50.7)	30 (7.9)	1 (0.3)	1.6 (3.8)

<sup>1)</sup> The pressure in port P must always be higher than the pressure in port A (Pp>Pa)

**2/2-way directional control valves, type VDH 30 EC**

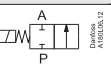
Pressure loss at max. flow: 7 barg (101.5 psig)  
 Max. opening/closing time: 150 ms/350 ms  
 Leakage at pressure higher than 10 barg (145 psig): 0 ml/min (0 GPM) drip proof  
 Degree of protection: IP 67

Type	Function symbol	Code number	Con- nection	Max. inlet pressure cont. barg (psig)	Max inlet pressure peak barg (psig)	Operation pressure <sup>1)</sup> barg (psig)	Max. flow l/min (GPM)	Min. flow l/min (GPM)	Weight incl. coil kg (lb)
VDH 30 EC 2/2 NC	 Danfoss A180L0048	180L0048	Cetop 3	140 (2.030)	200 (2,900)	3.5 (50.7)	30 (7.9)	1 (0.3)	1.2 (2.1)
VDH 30 EC 2/2 NO	 Danfoss A180L0049	180L0049	Cetop 3	140 (2.030)	170 (2,465)	3.5 (50.7)	30 (7.9)	1 (0.3)	1.2 (2.1)

<sup>1)</sup> The pressure in port P must always be higher than the pressure in port A (Pp>Pa)  
 VDH 30EC 2/2-way valves are supplied with screws and O-rings.

**2/2-way directional control valves, type VDH 60 E**

Pressure loss at max. flow: 8 barg (116 psig)  
 Max. opening/closing time: 150 ms/350 ms  
 Leakage at pressure higher than 10 barg (145 psig): 0 ml/min (0 GPM) drip proof  
 Degree of protection: IP 67

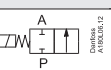
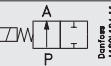
Type	Function symbol	Code number	Con- nection	Max. inlet pressure cont. barg (psig)	Max inlet pressure peak barg (psig)	Operation pressure <sup>1)</sup> barg (psig)	Max. flow l/min (GPM)	Min. flow l/min (GPM)	Weight incl. coil kg (lb)
VDH 60 E 2/2 NC	 Danfoss A180L0011	180L0011	G 1/2 "	140 (2.030)	200 (2,900)	3.5 (50.7)	60 (15.8)	1 (0.3)	1.6 (3.8)
VDH 60 E 2/2 NO	 Danfoss A180L0015	180L0015	G 1/2 "	140 (2.030)	170 (2,465)	3.5 (50.7)	60 (15.8)	1 (0.3)	1.6 (3.8)

<sup>1)</sup> The pressure in port P must always be higher than the pressure in port A (Pp>Pa)

**2/2-way directional control valves, type VDH 120 E**

Pressure loss at max. flow: 6 barg (87 psig)  
 Max. opening/closing time: 150 ms/400 ms  
 Leakage at pressure higher than 10 barg (145 psig): 0 ml/min (0 GPM) drip proof  
 Degree of protection: IP 67

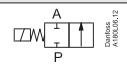
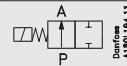
Type	Function symbol	Code number	Con-nection	Max. inlet pressure cont. barg (psig)	Max inlet pressure peak barg (psig)	Operation pressure <sup>1)</sup> barg (psig)	Max. flow l/min (GPM)	Min. flow l/min (GPM)	Weight incl. coil kg (lb)
VDH 120 E 2/2 NC		180L0001	G 1/2"	140 (2.030)	200 (2,900)	1 (14.5)	120 (31.6)	5 (1.5)	1.8 (3.9)
VDH 120 E 2/2 NO		180L0005	G 1/2"	140 (2.030)	170 (2,465)	1 (14.5)	120 (31.6)	5 (1.5)	1.8 (3.9)

<sup>1)</sup> The pressure in port P must always be higher than the pressure in port A (Pp > Pa)

All valves are supplied without coils which must be ordered separately.

**3. Code numbers for CETOP block**

Cetop 3 block	Steel type	Weight kg (lb)	Code number
Block for Cetop 2 valves	AISI 304	1.8 (3.9)	180L0062
Block for Cetop 3 valves	AISI 304	2.6 (5.7)	180L0063
Block for Cetop 4 valves	AISI 304	3.4 (7.5)	180L0064

**4. Code numbers for Coils**

Coil voltage	Code number
Coil 24V-50Hz-12W-IP 67	018F7920
Coil 220-230V-50Hz-12W-IP 67	018F7921
Coil 240V-50Hz-11W-IP 67	018F7924
Coil 24V-60Hz-14W-IP 67	018F7922
Coil 220V-60Hz-13W-IP 67	018F7925
Coil 240V-60Hz-15W-IP 67	018F7926
Coil 110V-50-60 Hz-15/13W-IP 67	018F7923
Coil 12V -DC-16W-IP 67	018F7913
Coil 24V-DC-16W-IP67	018F7914

ATEX - please consult the Danfoss sales organization for High Pressure Pumps.

5. Pressure losses at different flows

VDH 30 E 2/2 and VDH 30 EC 2/2

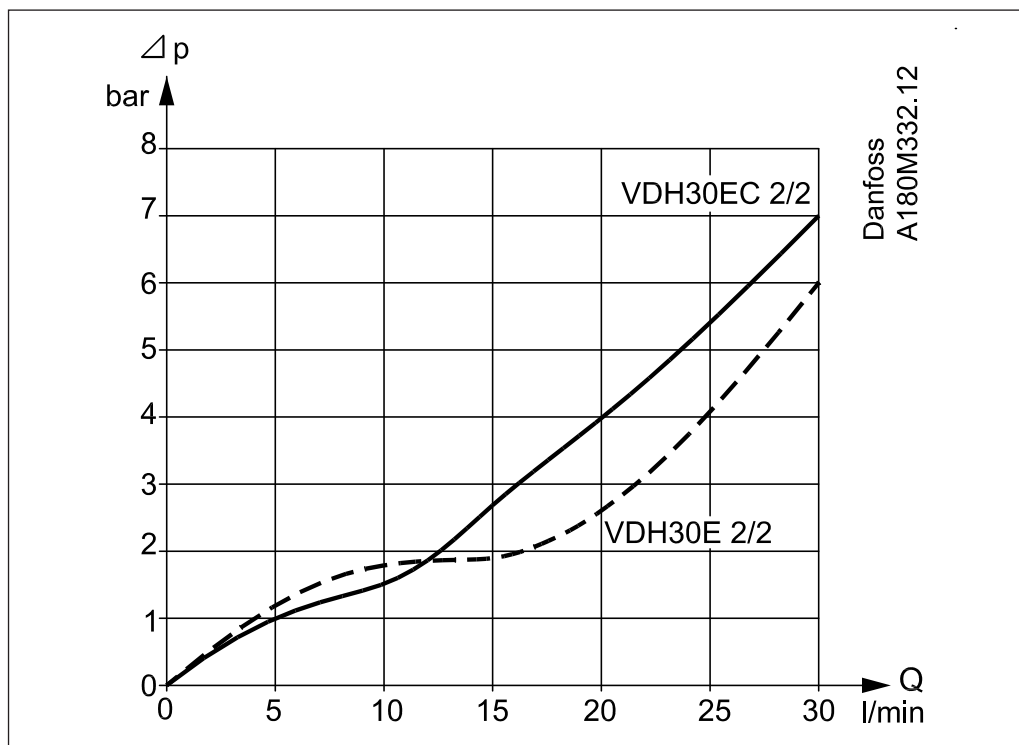

VDH 60 E 2/2 and VDH 120 E 2/2

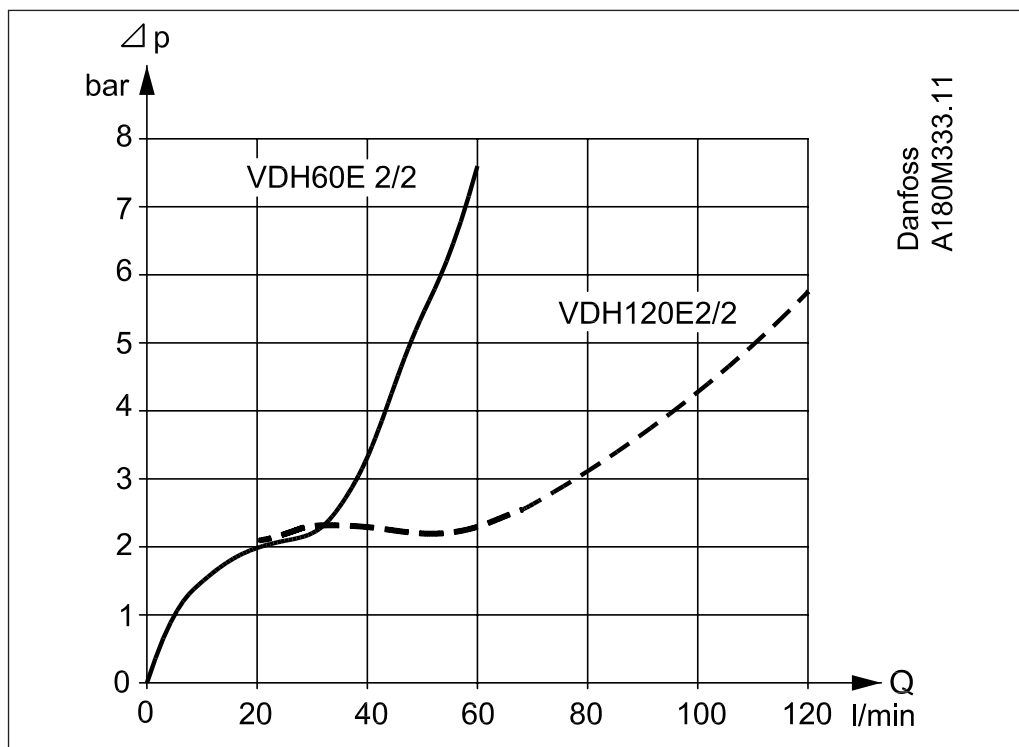

6. Cross-section of valves

VDH 30 E 2/2 and VDH 60 E 2/2

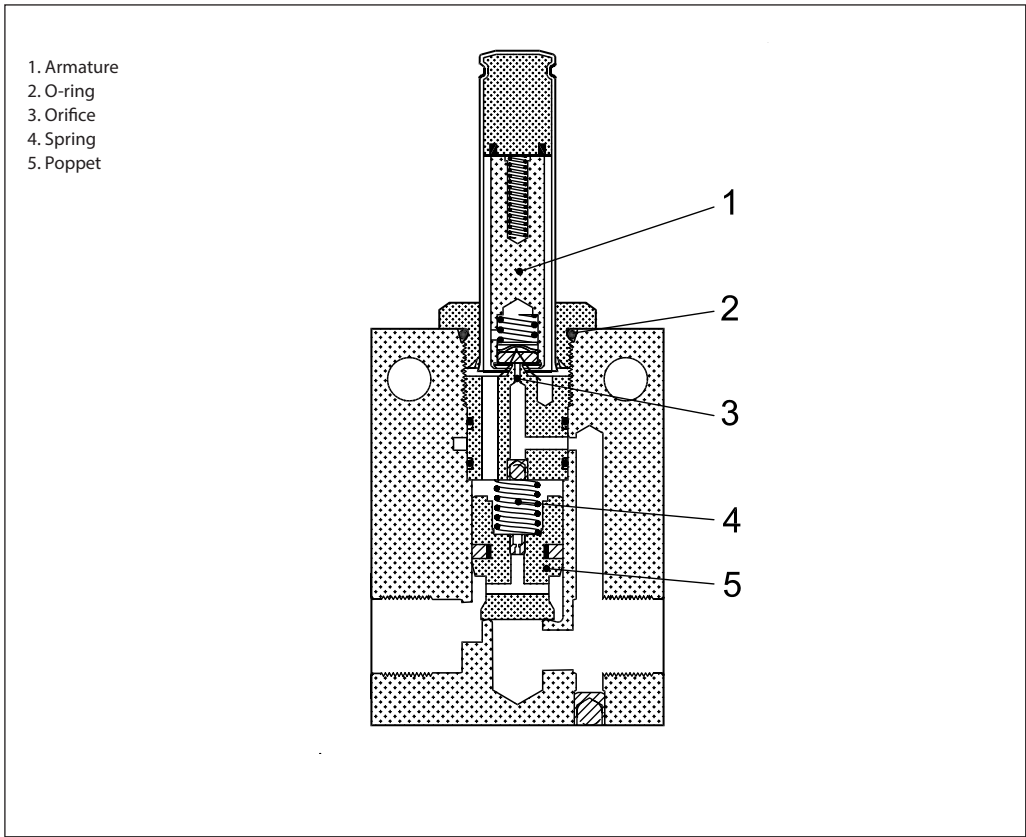

VDH 120 E 2/2

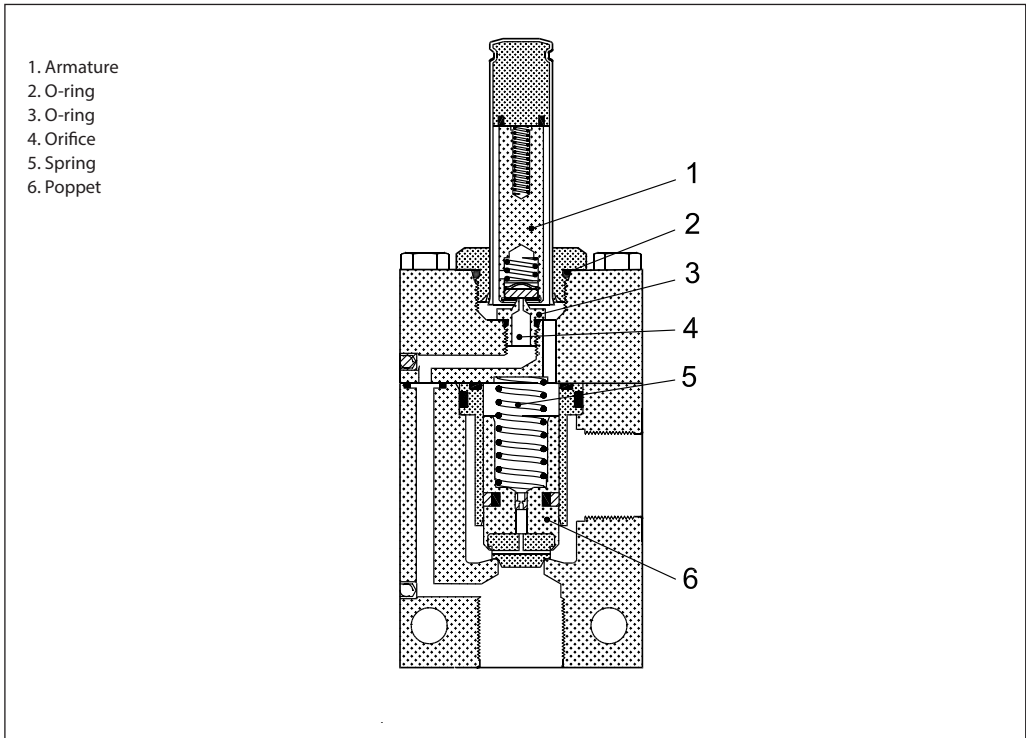

**VDH 30 E C 2/2 (Cetop)**

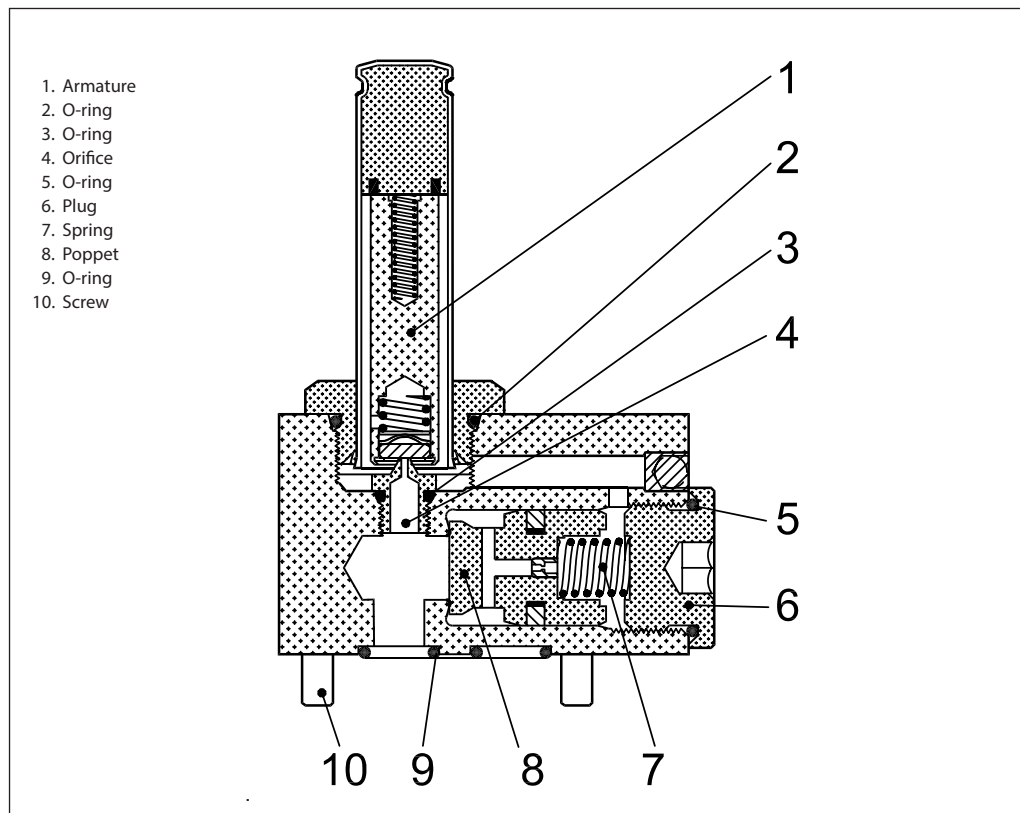

**7. Dimensions**

**VDH 30 E 2/2 and VDH 60 E 2/2**

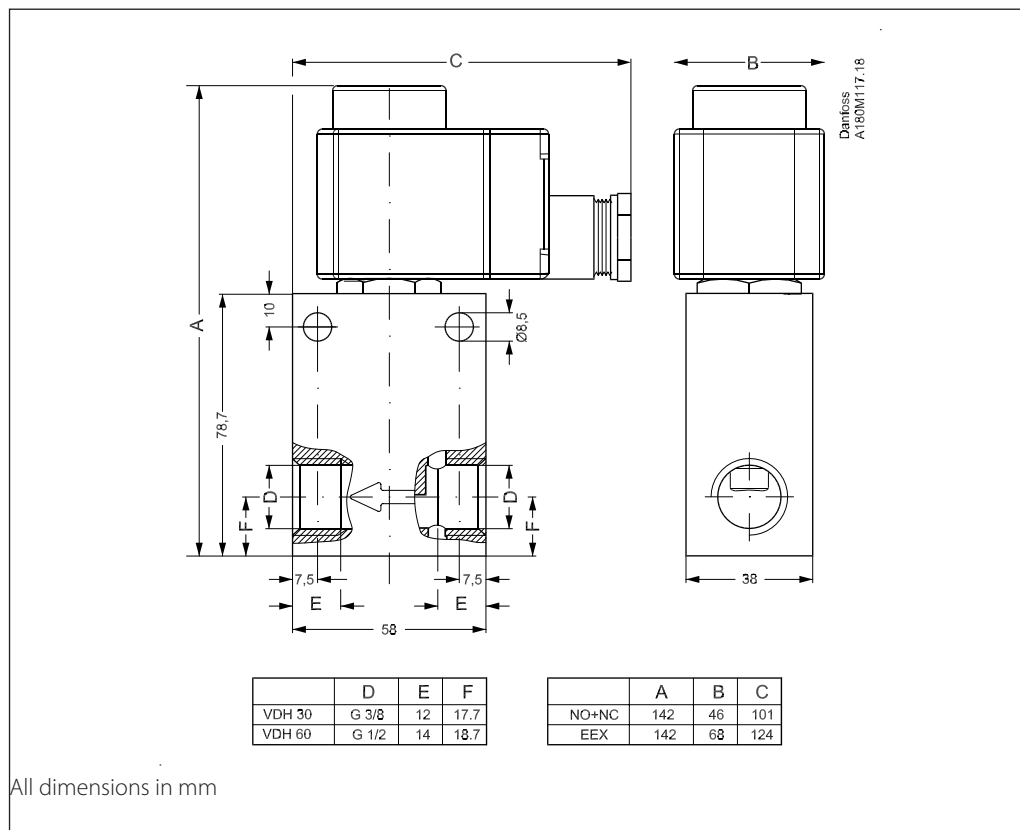

**VDH 120 E 2/2**

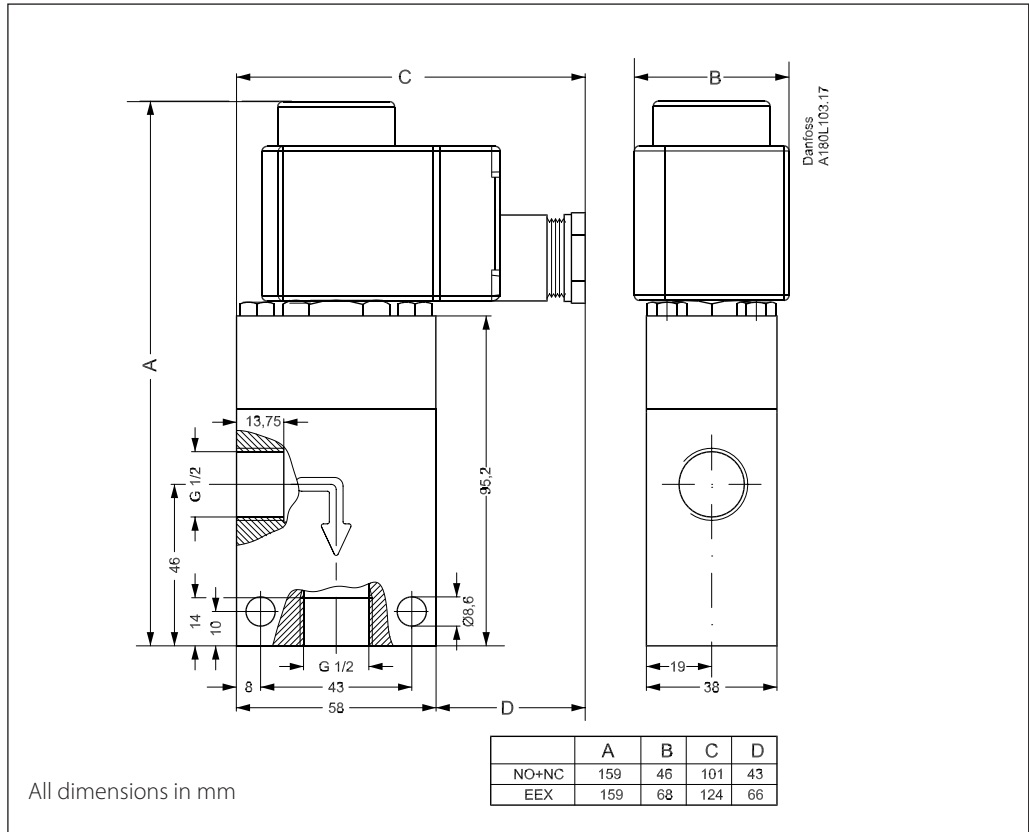

**VDH 30 EC 2/2 (Cetop)**

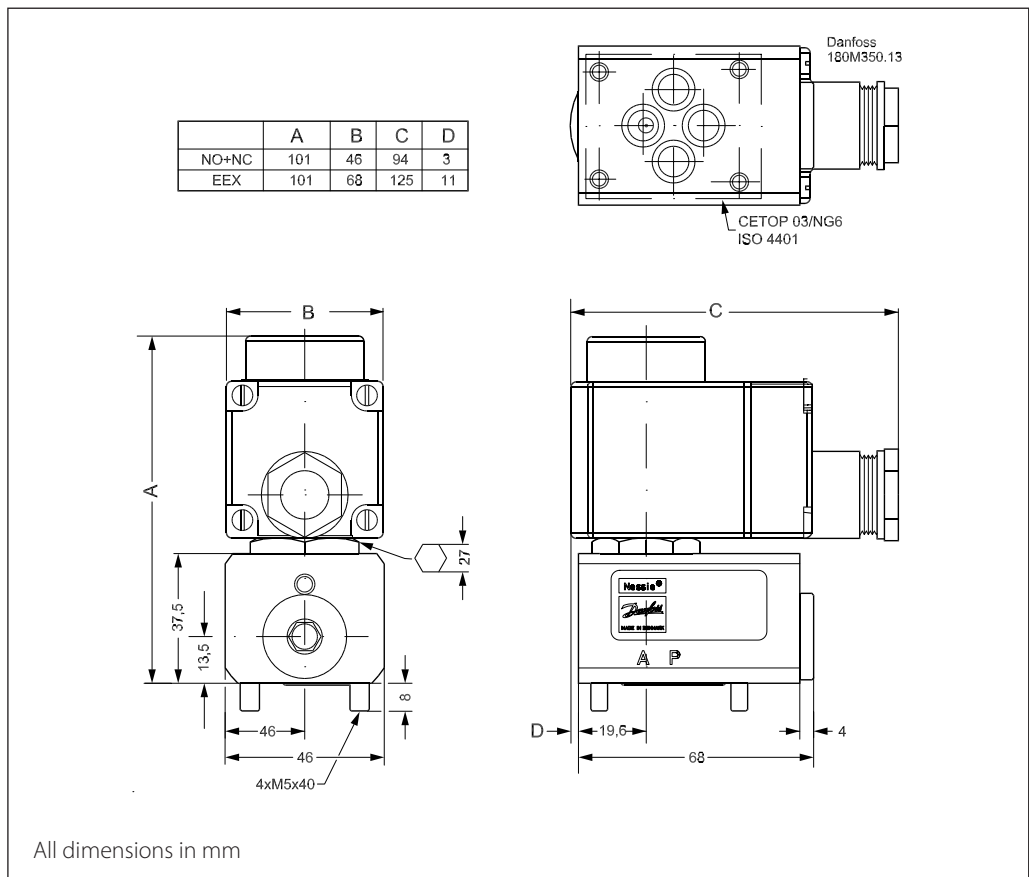



### Cetop blocks

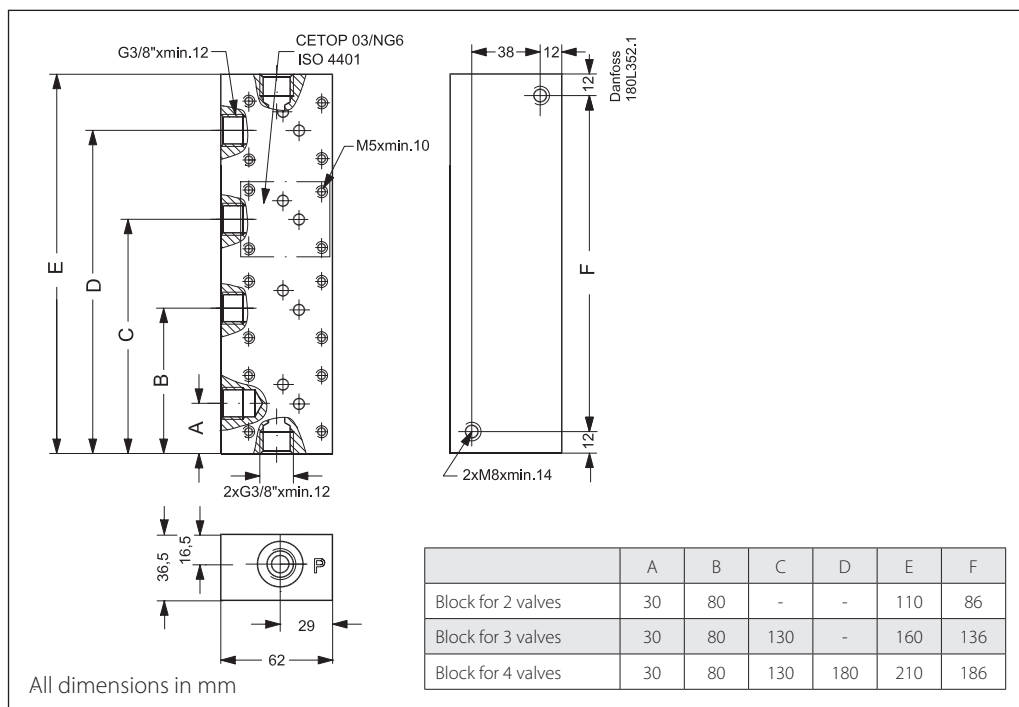

#### 8. Mounting of in-line valves

In-line valves are mounted in line in flow direction (follow the arrow on the valve) and fixed either

directly in the pipe connections or with bolts in the fixation holes on the valve.

#### 9. Mounting of valve on Cetop block

The valve is designed to be mounted on a block with CETOP 3-port connection. Four stainless steel screws and four O-rings are supplied with the valve for mounting. Remember to smear/

spray the threads on the screws with Molykote® D pasta from Dow Corning, or Klüber UH1 84-201 from Klüber lubrication, before mounting the valve.

#### 10. Mounting of coil on valve

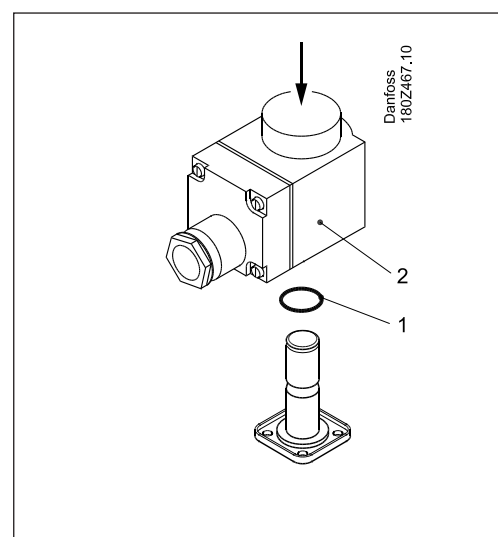
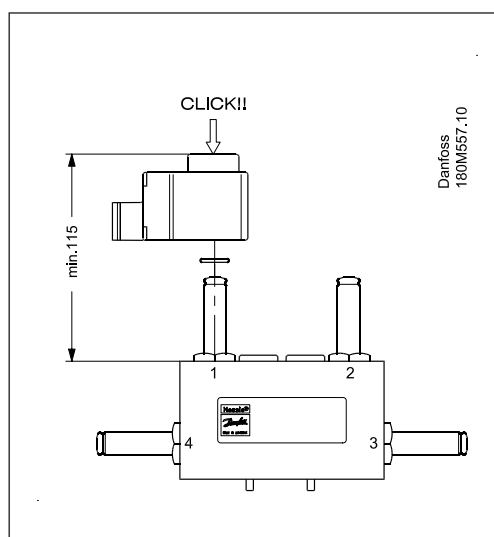

Coil on valves with short armature tubes (NC and NO valves)

1. Place the o-ring on the armature tube.
2. The coil is clicked on by means of a light pressure by hand – without using tools.

## 11. Dismounting of coil

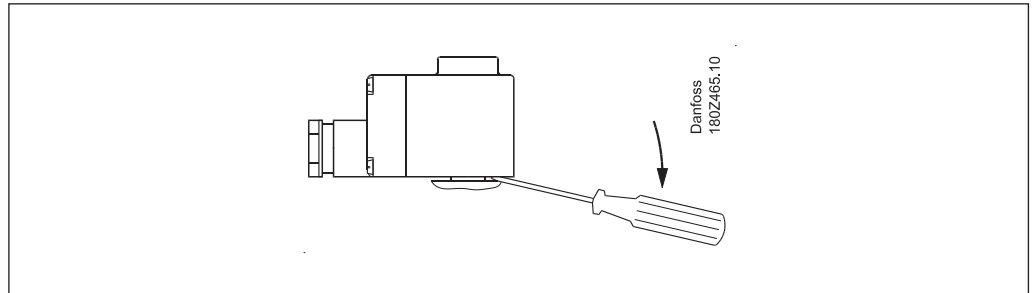

## 12. Accessories Code numbers

Spare parts	Code number
Poppet kit for VDH 30E 2/2, VDH 30 EC2/2 and 2/2 VDH 60E 2/2	180L5005
Poppet kit for VDH120E 2/2 (pos. 6)	180L5001
Armature kit, NC (pos. 1)	180L5002
Armature kit, NO (pos. 1)	180L5010
Orifice kit VDH 30 E 2/2	180Z0099
Orifice kit VDH 60 E 2/2	180Z0099
Orifice kit VDH 120 E 2/2	180Z0098

Tools	Application	Code number
Special tool for orifice insert	Mounting/dismounting of orifice Orifice insert in valve housing: 12 Nm $\pm$ 2 Nm Armature to be screwed into the valve housing: 60 Nm $\pm$ 2 Nm	180Z0034
Spool tool included in 180L5005	Mounting of spool	
Permanent magnet	For manual activation of valve	180Z0212

### Danfoss A/S

High Pressure Pumps • danfoss.com • +45 7488 2222 • highpressurepumps@danfoss.com

Any information, including, but not limited to information on selection of product, its application or use, product design, weight, dimensions, capacity or any other technical data in product manuals, catalogues descriptions, advertisements, etc. and whether made available in writing, orally, electronically, online or via download, shall be considered informative, and is only binding if and to the extent, explicit reference is made in a quotation or order confirmation. Danfoss cannot accept any responsibility for possible errors in catalogues, brochures, videos and other material. Danfoss reserves the right to alter its products without notice. This also applies to products ordered but not delivered provided that such alterations can be made without changes to form, fit or function of the product.

All trademarks in this material are property of Danfoss A/S or Danfoss group companies. Danfoss and the Danfoss logo are trademarks of Danfoss A/S. All rights reserved.