

Technical Information

**Low Speed High Torque Hydraulic Motors**

Xcel XLH, XLS, XL2, XL4 and XL6 Series

*Danfoss*

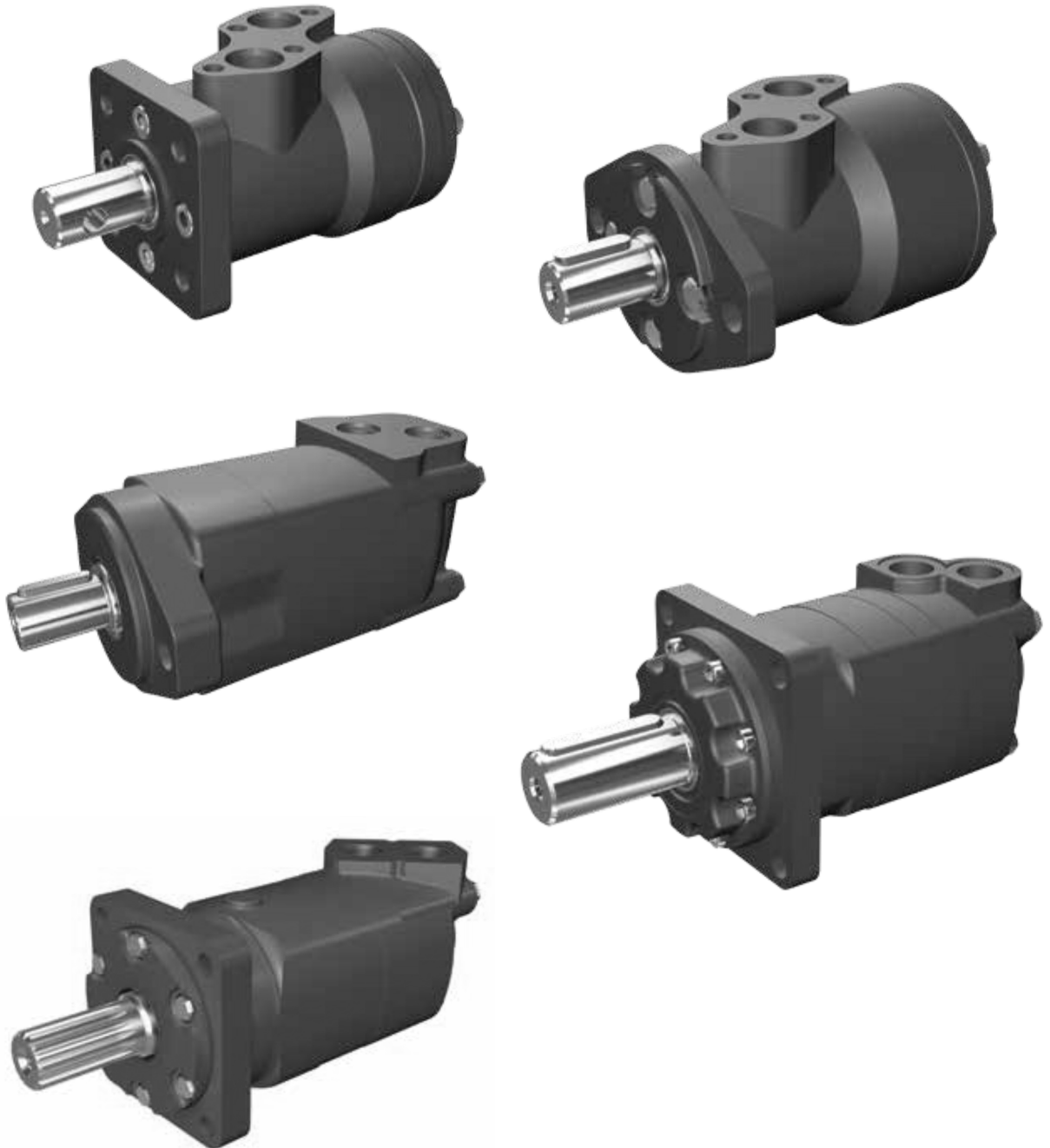

BC444173566050en-000101

# Contents

<b>XcelSpoolValve Motors</b> .....	<b>4</b>
Product Description, Features Benefits and Applications .....	<b>4</b>
<b>XcelXLH Series (016-)</b> .....	<b>5</b>
Specifications .....	<b>5</b>
PerformanceData .....	<b>6</b>
Dimensions Xcel XLH Series (016-) -Outline. ....	<b>12</b>
Model Code.....	<b>13</b>
<b>XcelXLS Series (036-)</b> .....	<b>14</b>
Specifications .....	<b>14</b>
PerformanceData .....	<b>15</b>
Dimensions Xcel XLS Series (036-) - Outline .....	<b>20</b>
Model Code.....	<b>21</b>
<b>Dimensions-Mounts</b> .....	<b>22</b>
<b>Dimensions -Shafts</b> .....	<b>23</b>
<b>Dimensions -Ports</b> .....	<b>24</b>
<b>Shaft Side Load Capacity and Case Pressure</b> .....	<b>25</b>
<b>XcelXL2Series</b> .....	<b>26</b>
Highlights .....	<b>26</b>
Specifications .....	<b>27</b>
Performance Data .....	<b>28</b>
Dimensions - Standard/Wheel Mount. ....	<b>33</b>
Dimensions - Standard/Wheel Mount with Integral Valves .....	<b>34</b>
Dimensions -Bearingless Mount .....	<b>35</b>
Installation Information Bearingless .....	<b>38</b>
Dimensions -MountingOptions .....	<b>39</b>
Dimensions -Shafts .....	<b>40</b>
Dimensions Ports .....	<b>42</b>
Shaft Side Load Capacity.....	<b>46</b>
Case Pressure andCase Porting .....	<b>47</b>
Model Code.....	<b>48</b>
<b>XcelXL4Series</b> .....	<b>50</b>
Highlights .....	<b>50</b>
Specifications .....	<b>51</b>
PerformanceData .....	<b>52</b>
Dimensions - Standard/Wheel Mount.....	<b>55</b>
Dimensions -Bearingless .....	<b>57</b>
Installation Information Bearingless .....	<b>58</b>
Dimensions -Shafts .....	<b>59</b>
Dimensions -Ports .....	<b>60</b>
Shaft Side Load Capacity... ..	<b>61</b>
Case Pressure andCase Porting .....	<b>62</b>
Model Code.....	<b>63</b>

# Contents

<b>XcelXL6Series</b> .....	<b>64</b>
Highlights .....	<b>64</b>
Specifications .....	<b>65</b>
PerformanceData .....	<b>66</b>
Dimensions-Standard/Wheel Mount.....	<b>70</b>
Dimensions-Global Mount(ISO) .....	<b>72</b>
Dimensions-Bearingless Mount.....	<b>73</b>
Installation Information Bearingless .....	<b>74</b>
Dimensions-Shafts .....	<b>75</b>
Dimensions- Ports .....	<b>76</b>
Shaft Side Load Capacity .....	<b>77</b>
Case pressure andCase Porting.....	<b>78</b>
Model Code.....	<b>79</b>

# Xcel Spool Valve Motors

## Product Description, Features Benefits and Applications



### Description

Danfoss' Xcel™ Series Low Speed High Torque Spool Valve motors offer the most popular features and are optimized to bring the highest value in medium duty applications.

Xcel spool valve motors distribute pressurized fluid into and out of the orbit gear set via valve slots integrated into the output shaft. The spool valve motors incorporate both valving and hydrodynamic journal bearings into a common shaft design. These motors incorporate the proven orbit motor principle to provide high torque at low speeds. Motor shaft rotation can be instantly reversed by changing direction of input/output flow while generating equal torque in either direction. The displacements available provide a wide variety of speeds and torque.

XLS motor feature Danfoss' Geroler™ technology to minimize friction and increase operating efficiency, while internal check valves limit case pressure to that of the outlet port.

### Features

- Proven orbit motor principle
- Hydrodynamic journal bearings
- Three moving components (Gerotor-star, drive, and shaft)
- Three –zone pressure design
- Optimized drive running angle
- Variety of displacements and shafts
- Designed for medium and low duty

### Benefits

- Compact, powerful package
- High efficiency
- Design flexibility
- Economically tailored solutions
- Long bearing life (at rated loads)

### Applications

- Aerial work platform
- Augers
- Conveyors
- Food processing
- Harvesters
- Machine tools
- Spreaders
- Turf care equipment
- W inches

#### Specifications XLS Motor

Geroler Element	11 Displacements
Flow L/min [GPM]	57 [15] Continuous*** 68 [18] Intermittent**
Speed rpm	Up to 800 rpm inter.**
ΔPressure bar [psi]	124 [1800] Cont.*** 138 [2000] Inter.**
Torque Nm [in-lbs]	426 [3770] Cont.*** 507 [4485] Inter.**

#### Specifications XLH Motor

Geroler Element	9 Displacements
Flow L/min [GPM]	57 [15] Continuous*** 68 [18] Intermittent**
Speed rpm	Up to 875 rpm inter.**
ΔPressure bar [psi]	138 [2000] Cont.*** 155 [2250] Inter.**
Torque Nm [in-lbs]	473 [4190] Cont.*** 512 [4540] Inter.**

\*\*\*Continuous-(Cont.) Continuous rating, motor may be run continuously at these ratings.

\*\*Intermittent-(Inter.) Intermittent operation, 10% of every minute.

# Xcel XLH Series (016-)

## Specifications

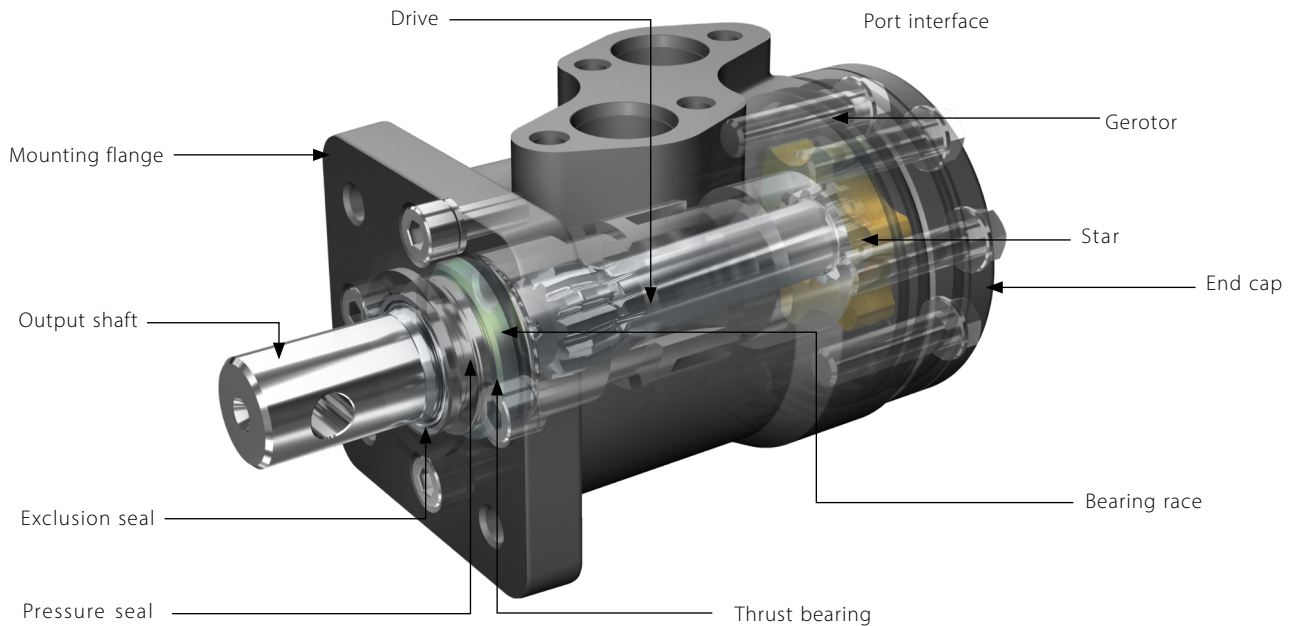

### Specification Data

Displacement cm <sup>3</sup> /r [in <sup>3</sup> /r]		53 [3.2]	63 [3.8]	80 [4.9]	100 [6.2]	125 [7.6]	160 [9.6]	200 [12.2]	245 [14.9]	315 [19.2]	390 [23.8]	485 [30.0]
Flow LPM [GPM]	Continuous	38 [10]	45 [12]	57 [15]	57 [15]	57 [15]	57 [15]	57 [15]	57 [15]	57 [15]	57 [15]	57 [15]
	Intermittent	45 [12]	53 [14]	68 [18]	68 [18]	68 [18]	68 [18]	68 [18]	68 [18]	68 [18]	68 [18]	68 [18]
Max. Speed RPM	Continuous	721	693	710	568	462	354	286	234	174	144	114
	Intermittent	864	806	848	678	551	421	341	282	209	171	138
Pressure ΔBar [Δpsi]	Continuous	124 [1800]	124 [1800]	124 [1800]	124 [1800]	124 [1800]	115 [1650]	110 [1600]	100 [1450]	90 [1300]	83 [1200]	69 [1000]
	Intermittent	138 [2000]	138 [2000]	138 [2000]	138 [2000]	138 [2000]	124 [1800]	124 [1800]	124 [1800]	124 [1800]	110 [1600]	90 [1300]
Torque* Nm [lb-in]	Continuous	83 [735]	104 [920]	130 [1150]	162 [1430]	200 [1770]	242 [2140]	287 [2540]	318 [2815]	377 [3340]	419 [3705]	426 [3770]
	Intermittent	93 [825]	116 [1025]	145 [1285]	181 [1600]	223 [1975]	260 [2300]	324 [2870]	391 [3460]	508 [4495]	547 [4840]	507 [4485]
Weight Kg [lbs]		5 [11.0]	5.3 [11.6]	5.5 [12.1]	6.1 [13.4]	6.2 [13.6]	6.4 [14.1]	6.7 [14.7]	7.1 [15.6]	7.4 [16.3]	7.7 [16.9]	8 [17.6]

Maximum Case Pressure: See case pressure seal limitation graph \*See shaft torque ratings for limitations .

**Note:** A simultaneous maximum torque and maximum speed NOT recommended .  
To assure best motor life, run motor for approximately 1 hour at 30% of rated pressure before application to full load .  
Be sure motor is filled with fluid prior to any load applications .

### Max. inlet pressure:

150 bar [2175 psi]  
Do not exceed Δ pressure rating (see chart above)

### ΔBar[Δpsi]:

The true pressure difference between inlet port and outlet port

### Continuous rating:

Motor may be run continuously at these ratings

### Intermittent operation:

10% of every minute

### Recommended fluids:

Premium quality anti-wear type hydraulic oil with a viscosity of not less than 20-32 cSt at operating temperature .

### Recommended system operating temp :

82oC [180 oF]

### Recommended filtration

Per ISO Cleanlinesscode, 4406:20/18/13

# Xcel XLH Series (016-)

## Performance Data

**Function Diagram: XLH motor 53cc**

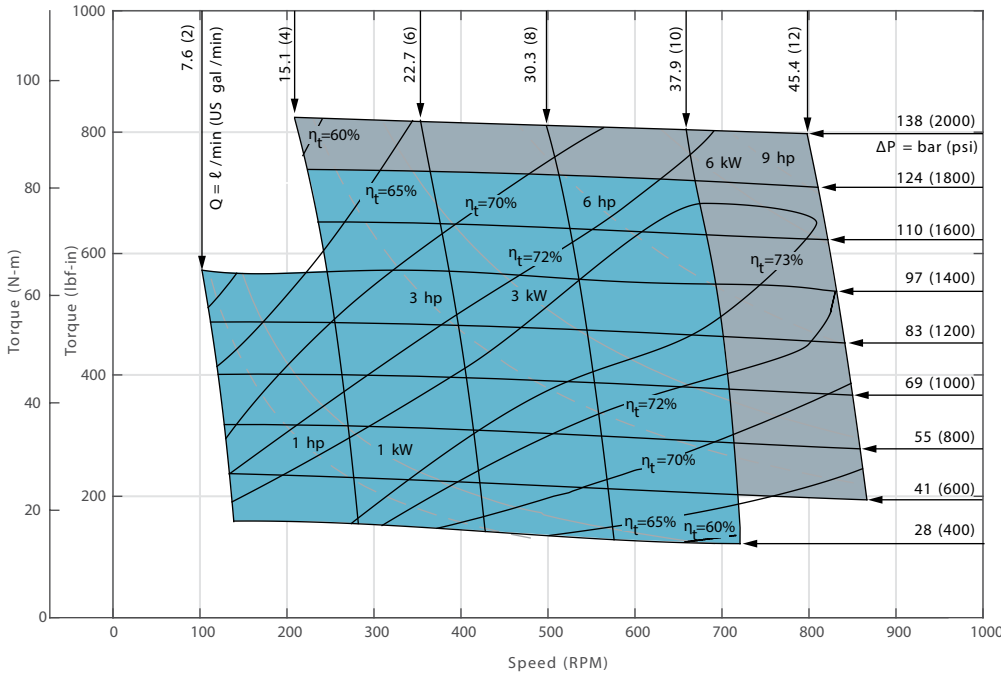

Performance data is typical at 25 cSt (120 SUS). Actual data may vary slightly from unit to unit in production.

$\eta_t$  = overall efficiency

Continuous

Intermittent

**Function Diagram: XLH motor 63cc**

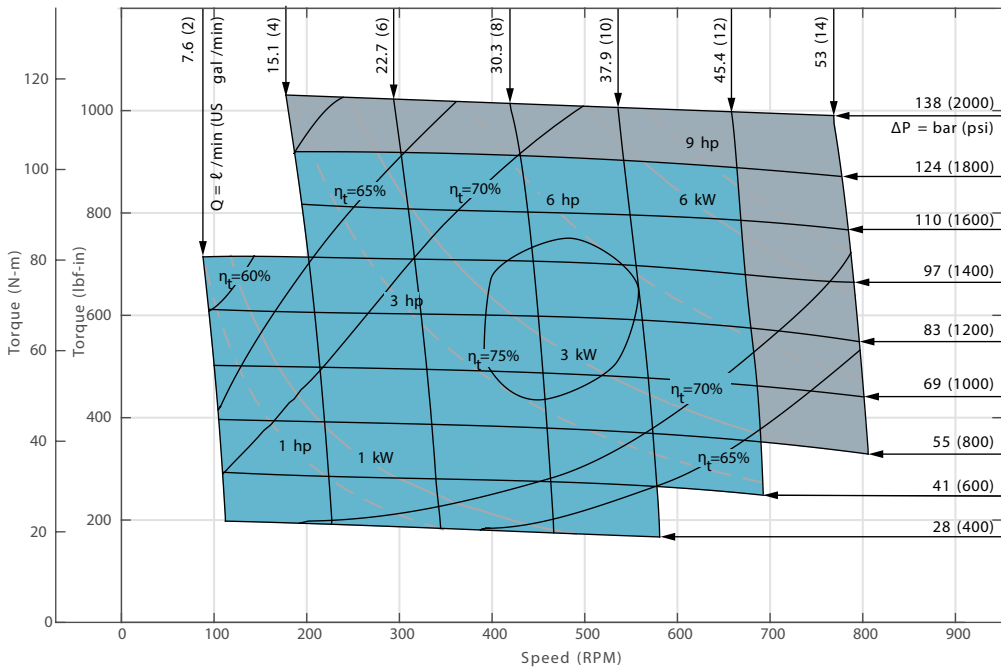

Function Diagram: XLH motor 80cc

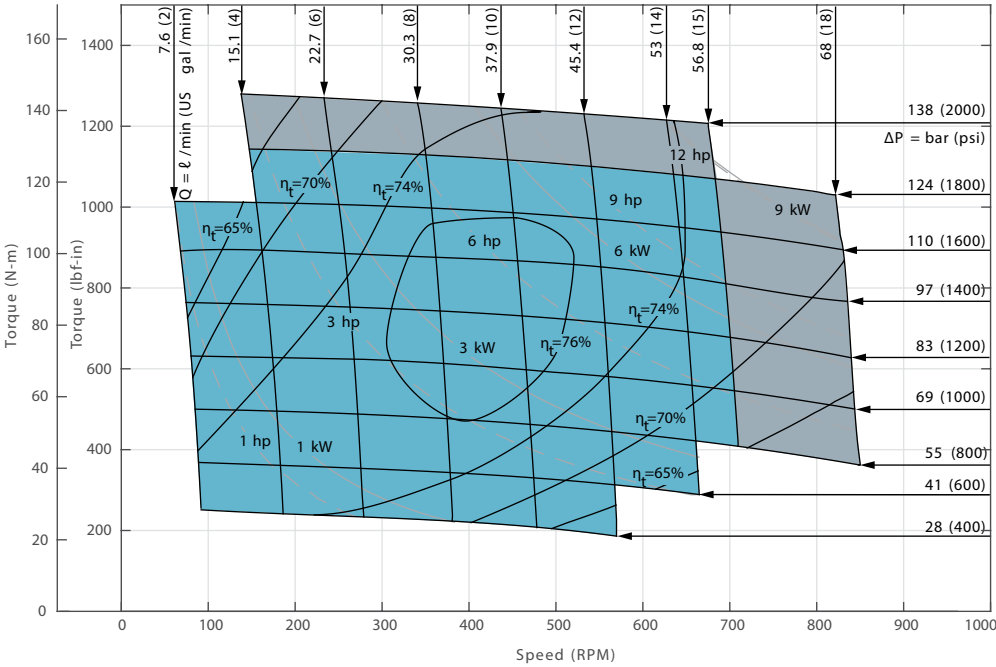

Performance data istypical at 25 cSt (120 SUS). Actual data may vary slightly from unit to unit in production .

$\eta_t$  = overall efficiency

Continuous

Intermittent

Function Diagram: XLH motor 100cc

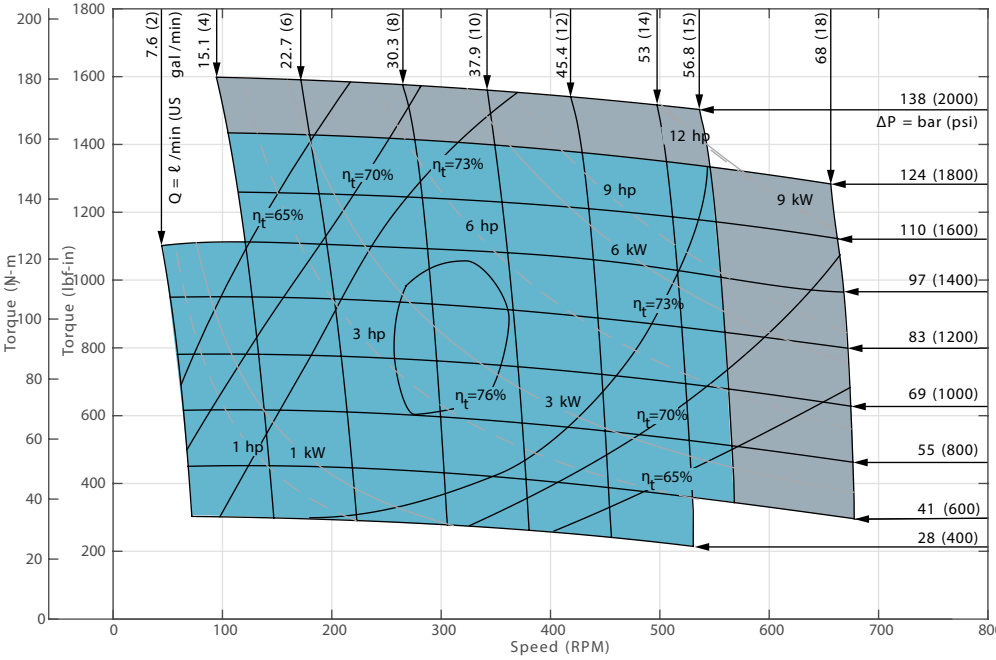

# Xcel XLH Series (016-)

## Performance Data

Function Diagram: XLH motor 125cc

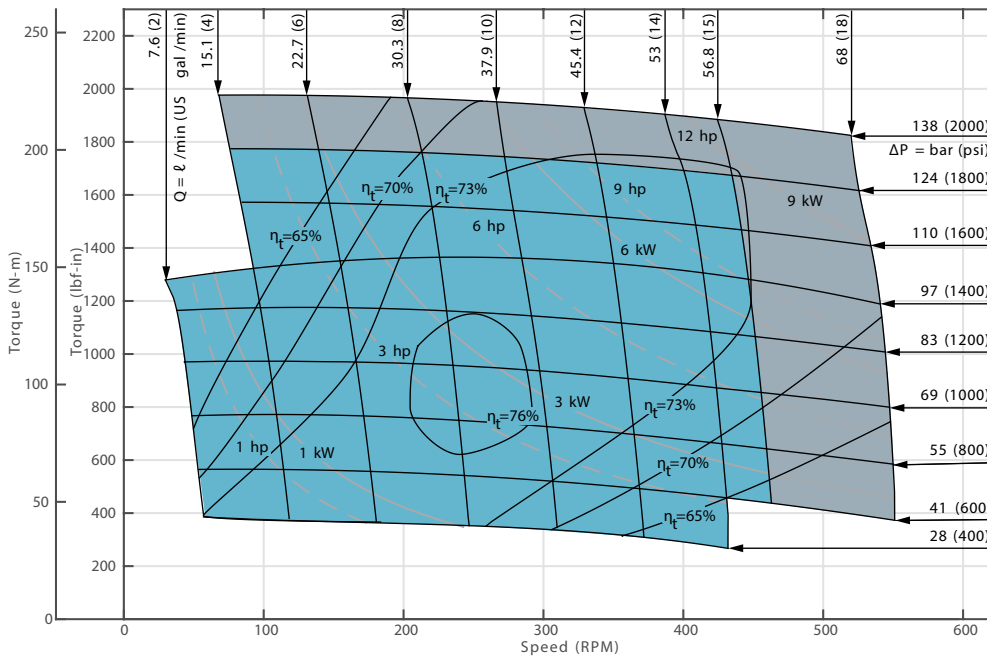

Performance data is typical at 25 cSt (120 SUS). Actual data may vary slightly from unit to unit in production .

$\eta_t$  = overall efficiency

- Continuous
- Intermittent

Function Diagram: XLH motor 160cc

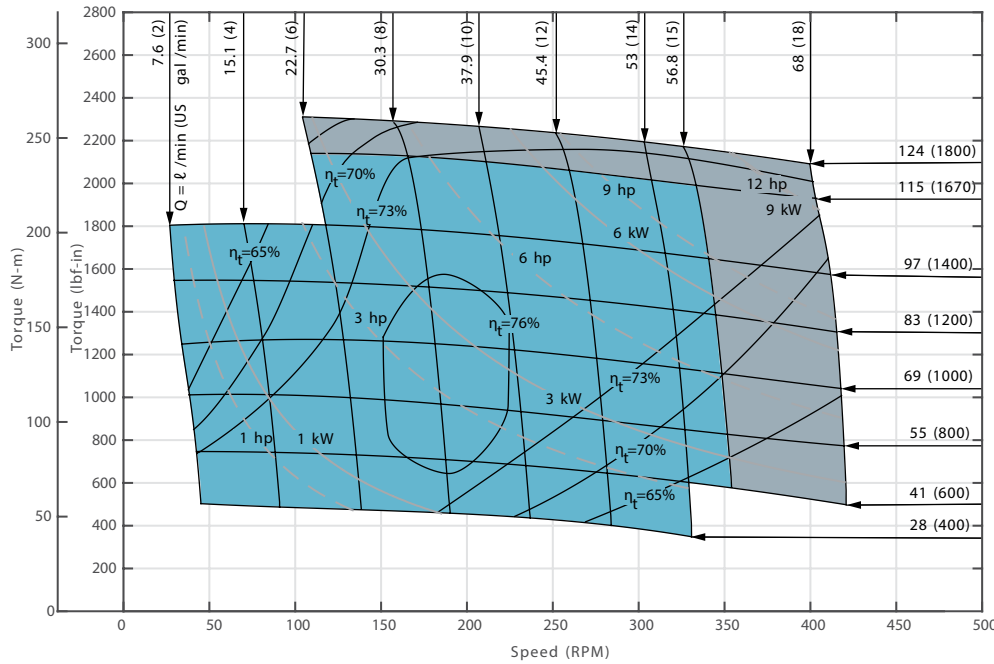



# Xcel XLH Series (016-)

## Performance Data

Function Diagram: XLH motor 200cc

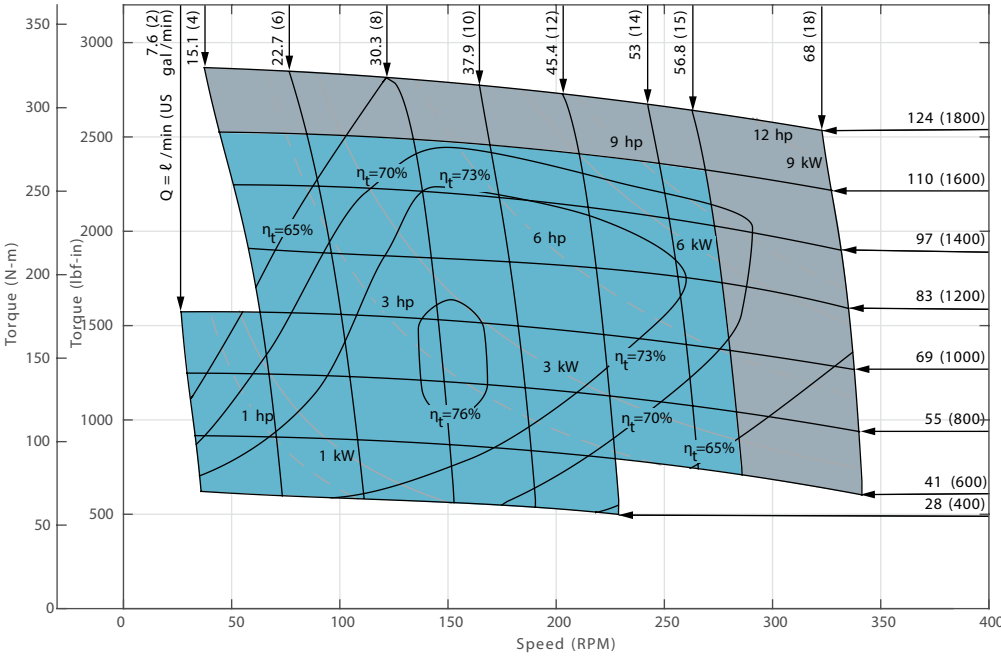

Performance data is typical at 25 cSt (120 SUS). Actual data may vary slightly from unit to unit in production.

- $\eta_t$  = overall efficiency
- Continuous
- Intermittent

Function Diagram: XLH motor 245cc

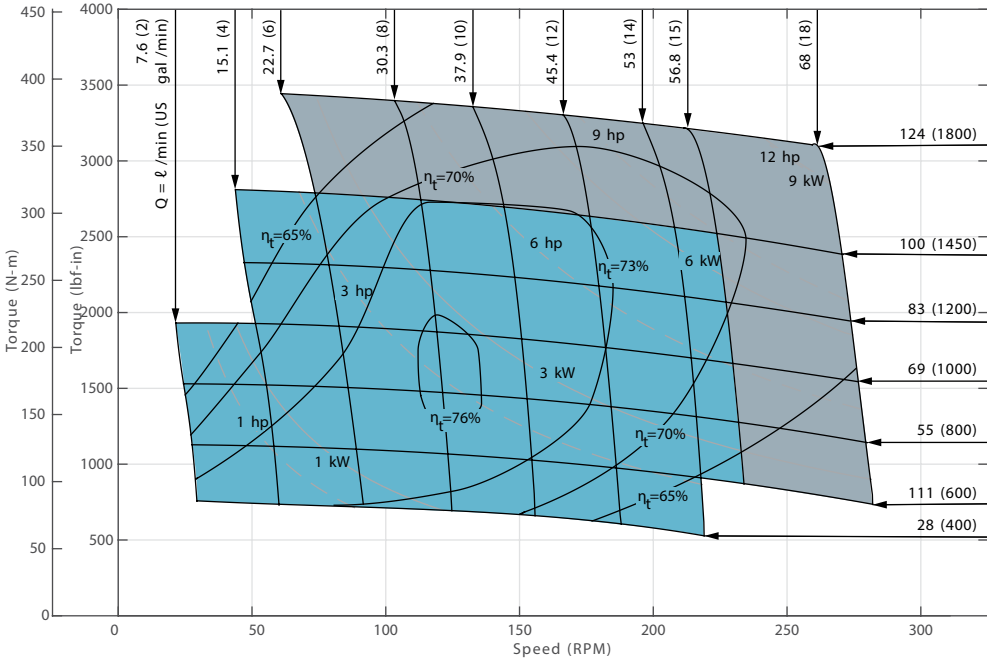

# Xcel XLH Series (016-)

## Performance Data

**Function Diagram: XLH motor 315cc**

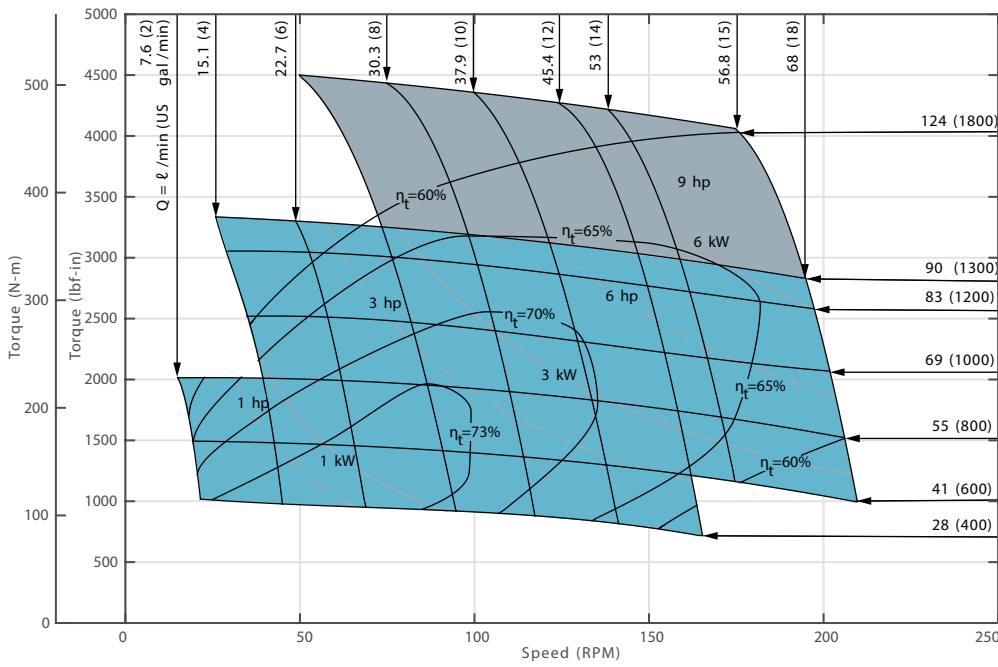

Performance data is typical at 25 cSt (120 SUS). Actual data may vary slightly from unit to unit in production.

$\eta_t$  = overall efficiency

Continuous

Intermittent

**Function Diagram: XLH motor 390cc**

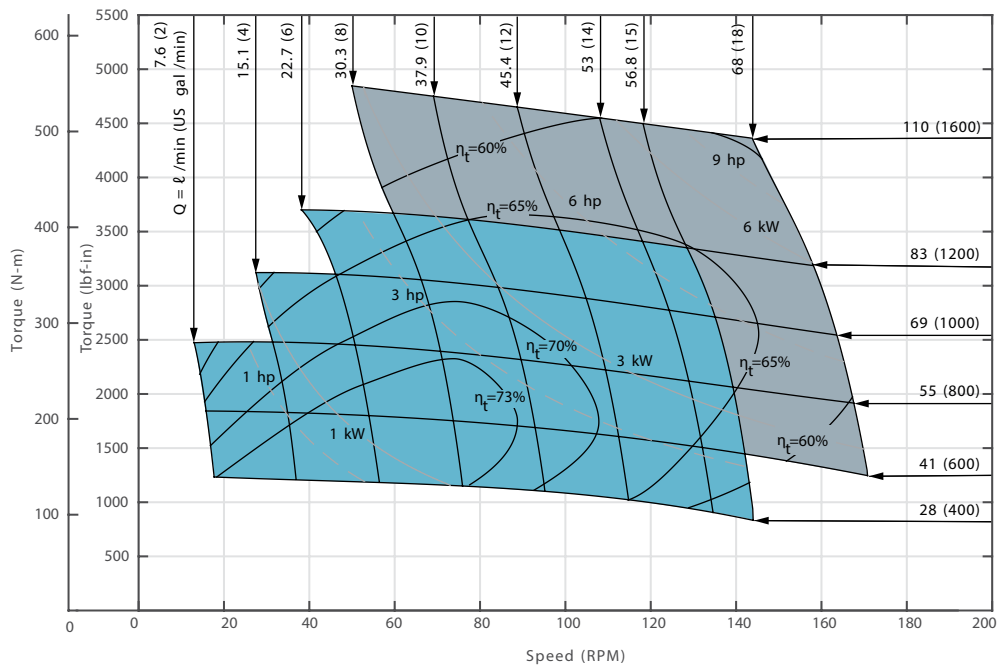

# Xcel XLH Series (016-)

## Performance Data

Function Diagram: XLH motor 485cc

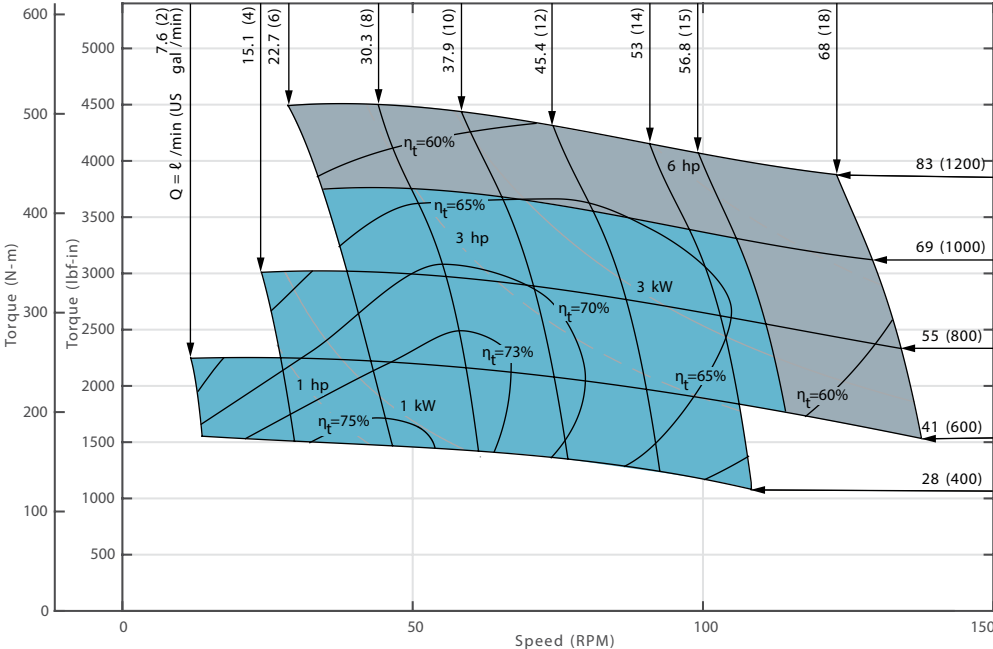

Performance data is typical at 25 cSt (120 SUS). Actual data may vary slightly from unit to unit in production.

- $\eta_t$  = overall efficiency
- Continuous
- Intermittent

# Xcel XLH Series (016-)

## Dimensions Xcel XLH Series - Outline

### Standard Rotation Viewed from Shaft End

Port A pressurized – CW

Port B pressurized – CCW

XLH Standard Shaft Seal and Section Seal Kit Number: **Z331-23**

XLH High Pressure Shaft Seal and Section Seal Kit Number: **Z331-41**

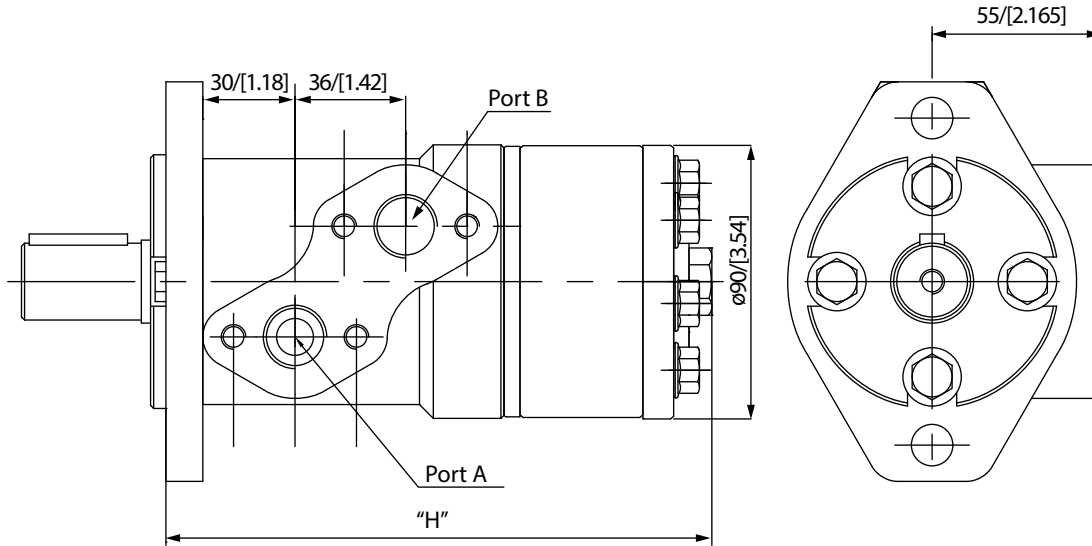

Dis p. c /r [in <sup>3</sup> /r]	53 [3.2]	63 [3.8]	80 [4.9]	100 [6.2]	125 [7.6]	160 [9.6]	200 [12.2]	245 [14.9]	315 [19.2]	390 [23.8]	485 [30.0]
H mm [in]	142 [5.59]	144 [5.67]	146 [5.75]	148 [5.83]	151 [5.95]	157 [6.18]	161 [6.34]	167 [6.57]	177 [6.96]	187 [7.36]	199 [7.83]

\* Based on the mounting flange SAEA .

# Xcel XLH Series (016-)

Model code

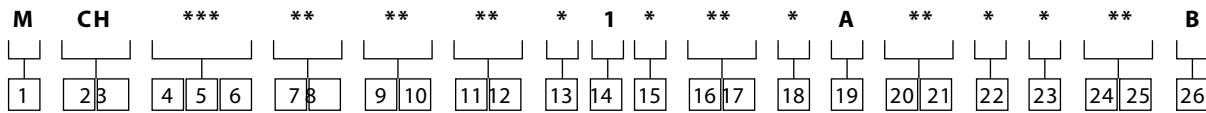

<b>1</b>	<b>Product</b>	
<b>M</b>	Motor	
<b>2</b> <b>3</b>	<b>Series</b>	
<b>CH</b>	XLH Series	
<b>4</b> <b>5</b> <b>6</b>	<b>Displacement cm<sup>3</sup>/r [in<sup>3</sup>/r]</b>	
<b>053</b>	53 [3 .2]	
<b>063</b>	63 [3 .8]	
<b>080</b>	80 [4 .9]	
<b>100</b>	100 [6 .2]	
<b>125</b>	125 [7 .6]	
<b>160</b>	160 [9 .6]	
<b>200</b>	200 [12 .2]	
<b>245</b>	245 [14 .9]	
<b>315</b>	315 [19 .2]	
<b>390</b>	390 [23 .8]	
<b>485</b>	485 [30 .0]	
<b>7</b> <b>8</b>	<b>Mounting flange</b>	
<b>AA</b>	2 bolt standard, SAE A . 82 .55x5, pilot 2-13 .5 Dia . M ounting holes on 106 .4 Dia	
<b>AC</b>	2 bolt standard, 82 .55x2 .8 pilot . 2-13 .5 Dia . M ounting holes on 106 .4 Dia .	
<b>AD</b>	4 B olt standard, 44 .40 Dia . x 3 .05 Pilot, 375-16 UNC-2B, M ounting Holes on 82 .55 Dia . B .C .	
<b>AE</b>	4 B olt standard, 44 .40 Dia . x 3 .05 Pilot, M10x1 .5-6H M ounting Holes on 82 .55 Dia . B .C .	
<b>9</b> <b>10</b>	<b>Output shaft</b>	
<b>1</b>	25 dia . Straight, parallel key A8x7x32, M 8 hole in shaft end . DIN 6885	
<b>2</b>	25 Dia . Straight, 5mm extra length . parallel key A8x7x32, M 8 hole in shaft end, DIN 6885	
<b>3</b>	25 .4Dia . Straight, parallel key ¼x¼x1¼, M 8 hole in shaft end, B S 46	
<b>4</b>	25 .4 Dia . Splined shaft, SAE6B, .250-20 UNC-2B hole in the shaft end .	
<b>5</b>	25 .4 Dia . Straight, parallel key,.250-20 UNC 2B hole in the shaft end .	
<b>08</b>	25 .4 Dia . Straight, 10 .3 [ .405] Dia . Cross hole 15 .7 [ .618] from .250-20 UNC-2B hole in the shaft end .	

<b>11</b> <b>12</b>	<b>Main ports</b>	
<b>AA</b>	Staggered port 2-G1/2 ISO228/1	
<b>AE</b>	Staggered port 2-0 .875-14UNF-2B O-ring or manifold ports (4-M 8-6H mounting holes)	
<b>13</b>	<b>Case drain options</b>	
<b>0</b>	None	
<b>1</b>	G1/4 ISO228/1	
<b>3</b>	0 .4375-20UNF-2B	
<b>14</b>	<b>Gerotor options</b>	
<b>1</b>	Standard Gerotor	
<b>15</b>	<b>Shaft options</b>	
<b>0</b>	Standard shaft	
<b>16</b> <b>17</b>	<b>Seal options</b>	
<b>0</b>	Standard seals	
<b>1</b>	Seal guard	
<b>2</b>	High pressure seal shaft	
<b>18</b>	<b>Speed sensor options</b>	
<b>0</b>	None	
<b>19</b>	<b>Manifold block options</b>	
<b>A</b>	None	
<b>20</b> <b>21</b>	<b>Special features (hardware)</b>	
<b>00</b>	None	
<b>22</b>	<b>Special assembly instructions</b>	
<b>0</b>	None	
<b>1</b>	Reverse rotation	
<b>23</b>	<b>Paint</b>	
<b>C</b>	Black primer	
<b>24</b> <b>25</b>	<b>Customer identification or name plate</b>	
<b>00</b>	None	
<b>26</b>	<b>Design code</b>	
<b>B</b>	Second	

# Xcel XLS Series (036-)

## Specifications

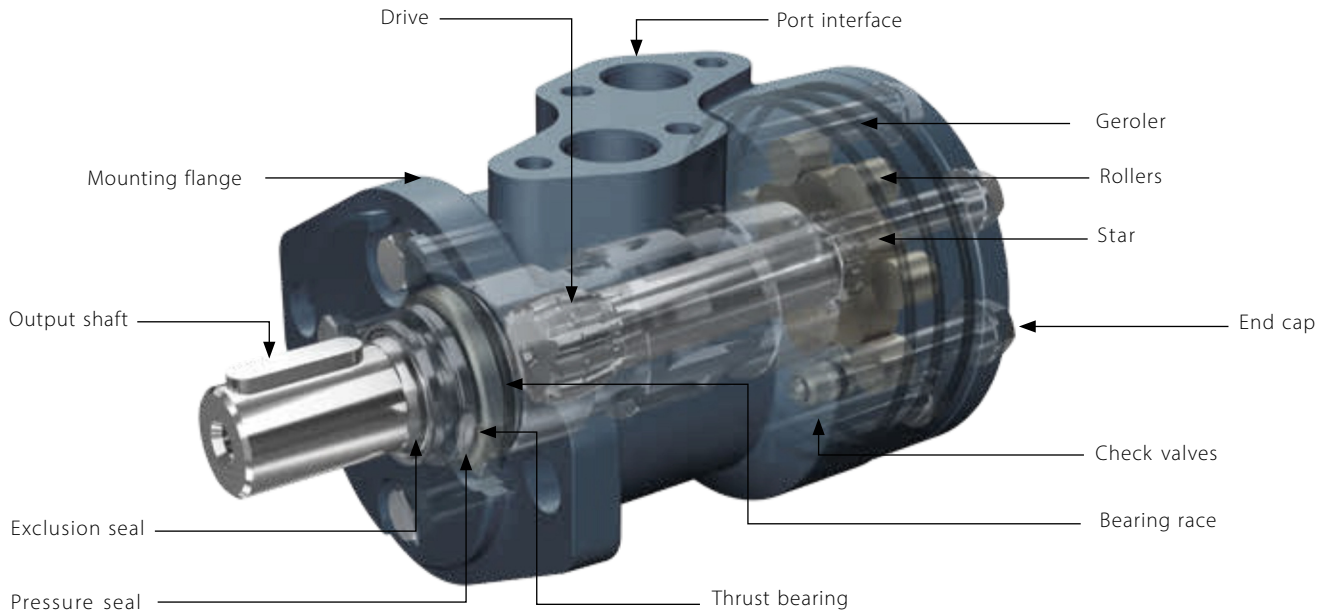

The XLS series features the same basic construction and layout as the XLH series . XLS uses Geroler technology to further reduce friction and increase volumetric efficiency . XLS also has

check valves as standard that drain the case chamber to the motor outlet port . In many applications this enablesthe case drain to be omitted .

### Specification Data

Displacement cm <sup>3</sup> /r [in <sup>3</sup> /r]	50 [3.1]	80 [4.9]	100 [6.2]	130 [8.0]	160 [9.6]	195 [11.9]	245 [14.9]	305 [18.7]	395 [24.0]
Flow LPM [GPM]	Continuous	38 [10]	57 [15]	57 [15]	57 [15]	57 [15]	57 [15]	57 [15]	57 [15]
	Intermittent	45 [12]	68 [18]	68 [18]	68 [18]	68 [18]	68 [18]	68 [18]	68 [18]
Max. Speed RPM	Continuous	741	701	554	430	353	286	230	180
	Intermittent	875	830	665	515	425	344	275	215
Pressure ΔBar [Δpsi]	Continuous	138 [2000]	138 [2000]	138 [2000]	124 [1800]	124 [1800]	124 [1800]	110 [1600]	97 [1405]
	Intermittent	155 [2250]	155 [2250]	155 [2250]	138 [2000]	138 [2000]	138 [2000]	124 [1800]	110 [1600]
Torque* Nm [lb-in]	Continuous	103 [920]	171 [1515]	216 [1310]	246 [2180]	298 [2640]	342 [3030]	391 [3465]	417 [3695]
	Intermittent	116 [1030]	192 [1700]	241 [2135]	273 [2420]	328 [2905]	379 [3360]	437 [3870]	444 [3935]
Weight Kg [lbs]	6.3 [13.8]	7.0 [15.4]	7.5 [16.5]	7.7 [16.9]	7.1 [15.6]	8.0 [17.6]	8.4 [18.5]	9.4 [20.6]	9.6 [21.1]

Maximum Case Pressure: See case pressure seal limitation graph

\*See shaft torque ratings for limitations .

**Note:** A simultaneous maximum torque and maximum speed NOT recommended . To assure best motor life, run motor for approximately **1 hour at 30%** of rated pressure before application to full load . Be sure motor is filled with fluid prior to any load applications .

### Max. inlet pressure:

170 bar [2465 psi]

Do not exceed Δ pressure rating (see chart above)

### ΔBar[Δpsi]:

The true pressure difference between inlet port and outlet port

### Continuous rating:

Motor may be run continuously at these ratings

### Intermittent operation:

10% of every minute

### Recommended fluids:

Premium quality anti-wear type hydraulic oil with a viscosity of not less than 20-32 cSt at operating temperature .

### Recommended system operating temp:

82oC [180 oF]

### Recommended filtration

Per ISO Cleanlinesscode, 4406:20/18/13

Function Diagram: XLS motor 50 cc

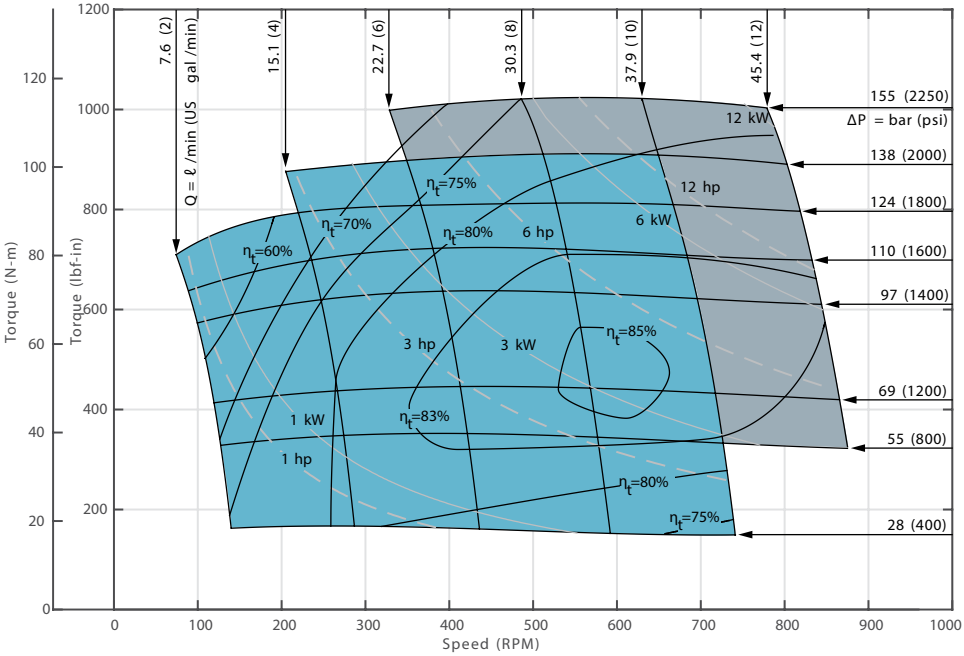

Performance data is typical at 25 cSt (120 SUS). Actual data may vary slightly from unit to unit in production.

- $\eta_t$  = overall efficiency
- Continuous
- Intermittent

Function Diagram: XLS motor 80 cc

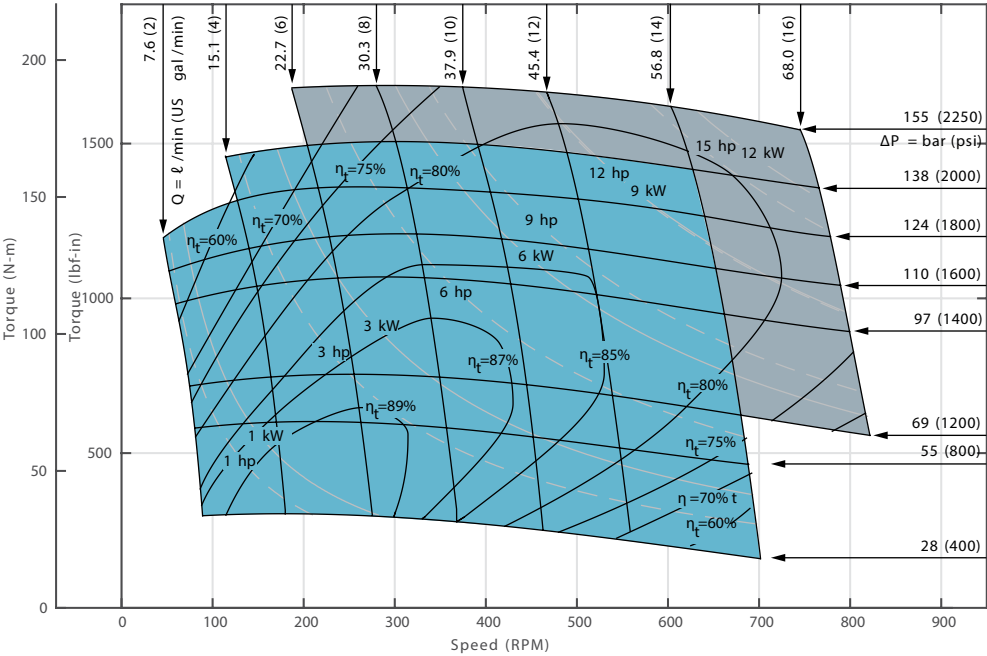

# Xcel XLS Series (036-)

## Performance Data

Function Diagram: XLS motor 100 cc

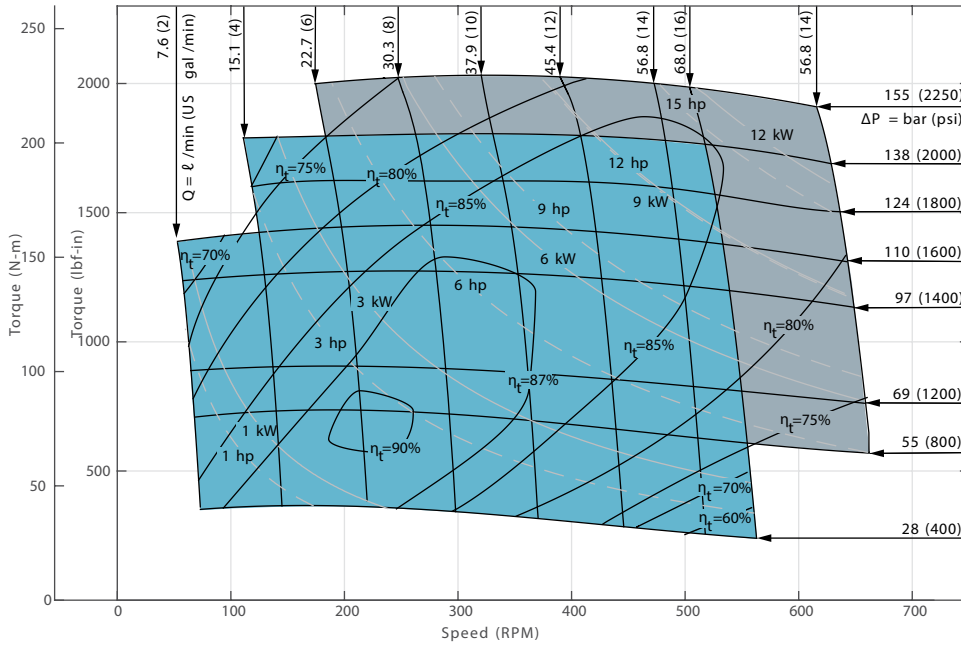

Performance data is typical at 25 cSt (120 SUS). Actual data may vary slightly from unit to unit in production.

$\eta_t$  = overall efficiency

- Continuous
- Intermittent

Function Diagram: XLS motor 130 cc

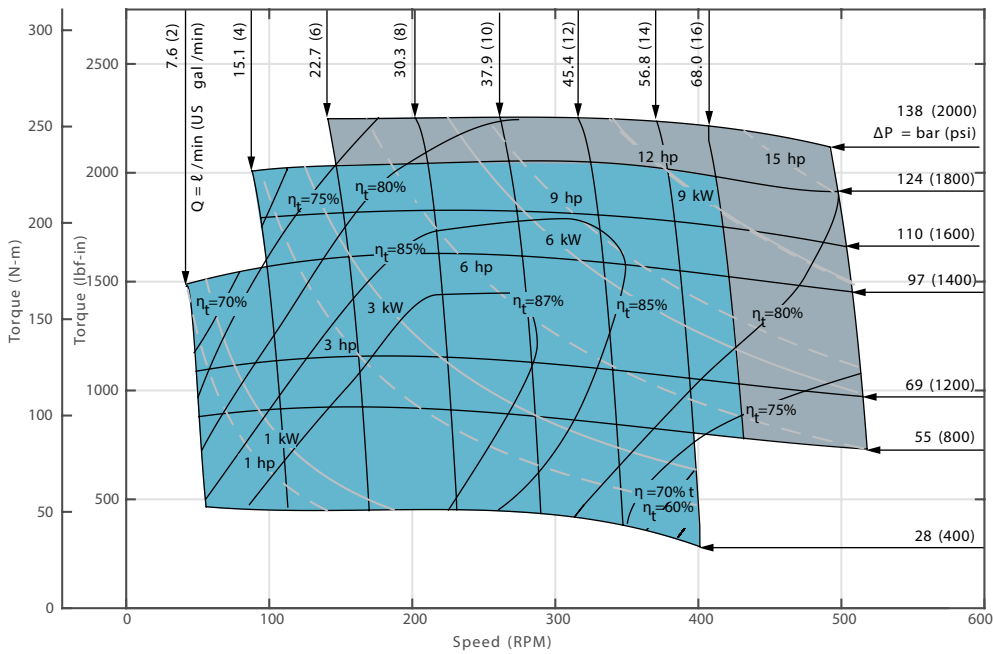



Function Diagram: XLS motor 160 cc

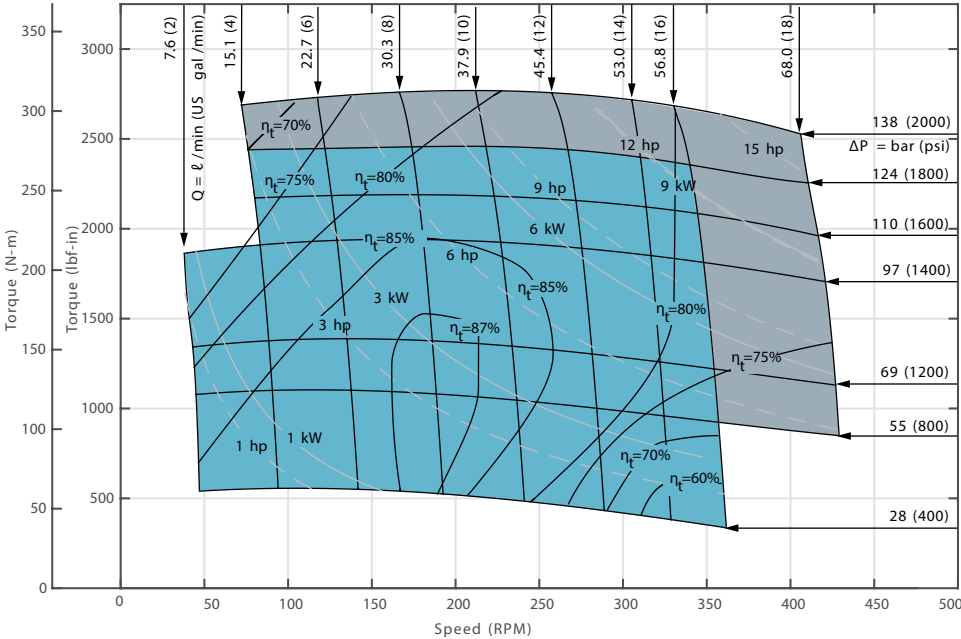

Performance data is typical at 25 cSt (120 SUS). Actual data may vary slightly from unit to unit in production.

$\eta_t$  = overall efficiency

- Continuous
- Intermittent

Function Diagram: XLS motor 195 cc

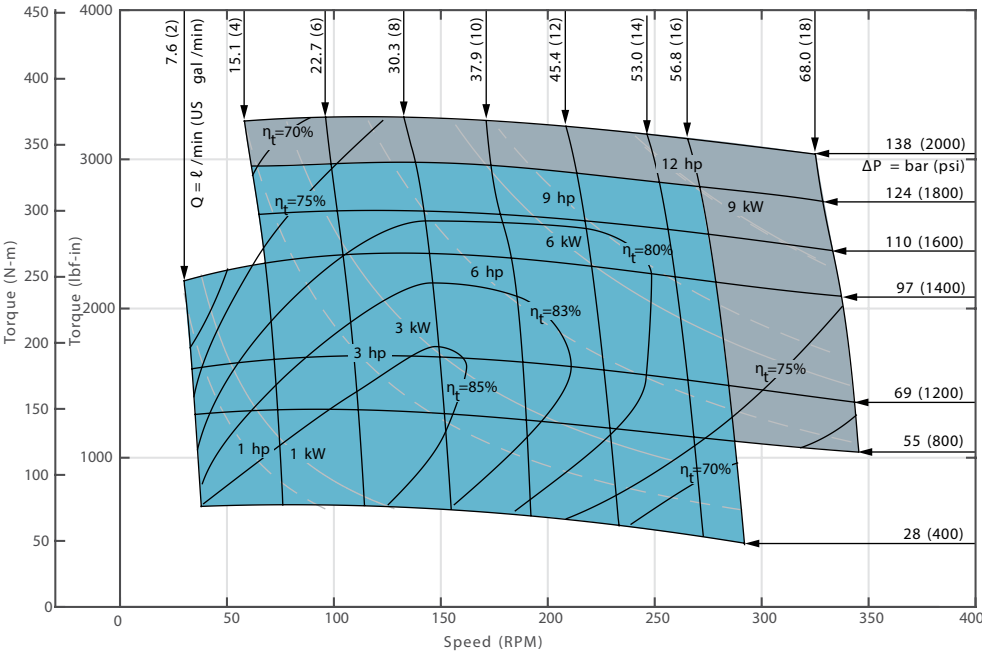

# Xcel XLS Series (036-)

## Performance Data

**Function Diagram: XLS motor 245 cc**

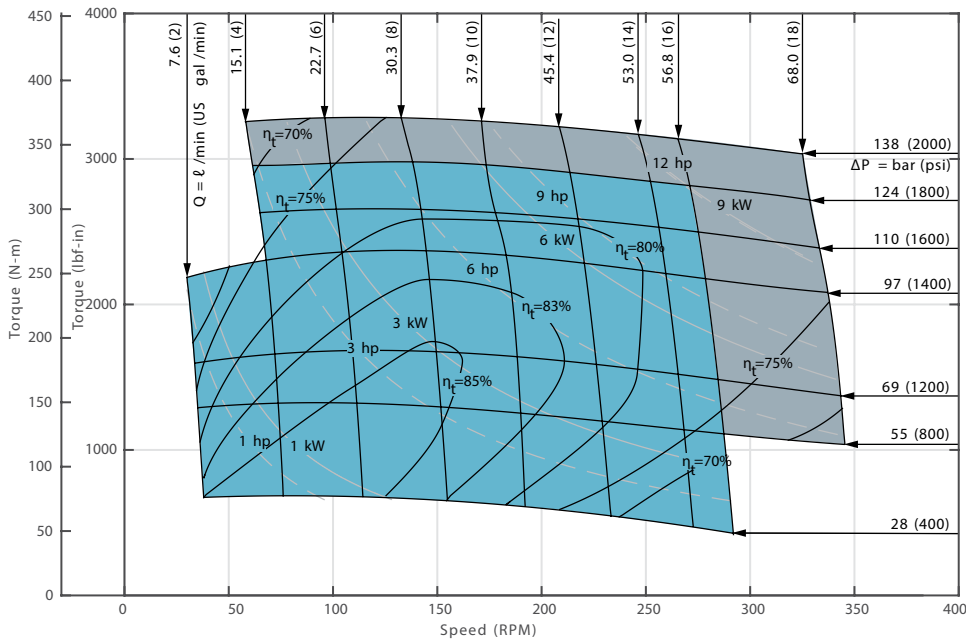

Performance data is typical at 25 cSt (120 SUS). Actual data may vary slightly from unit to unit in production.

$\eta_t$  = overall efficiency

- Continuous
- Intermittent

**Function Diagram: XLS motor 305 cc**

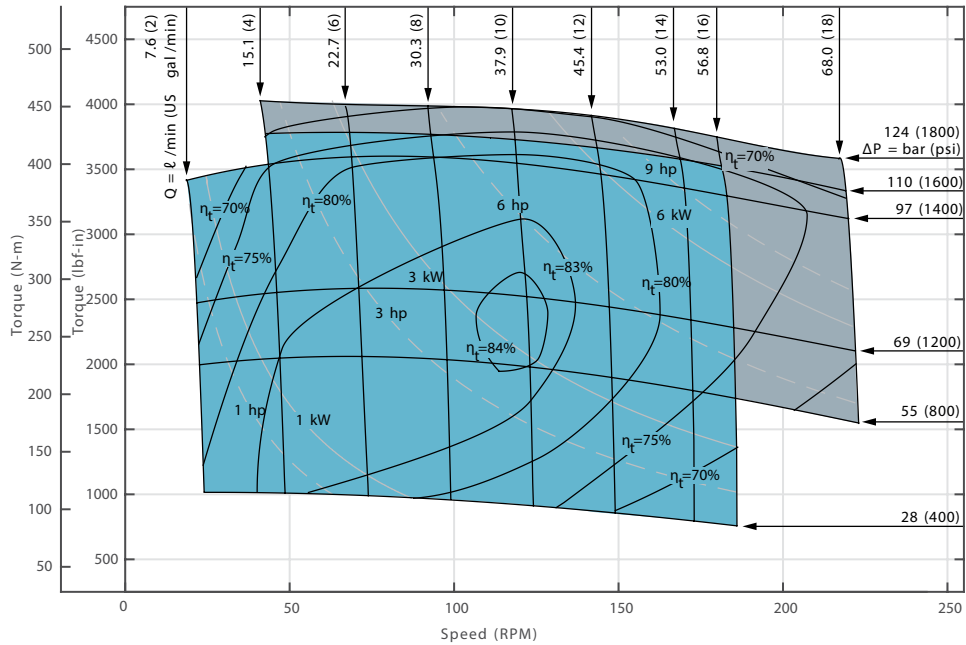

Function Diagram: XLS motor 395 cc

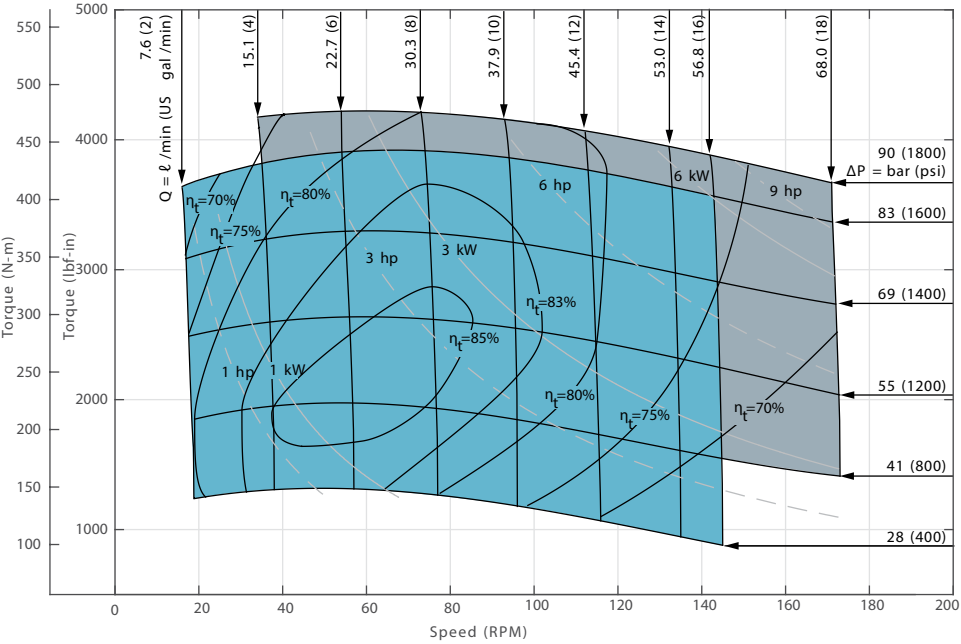

Performance data is typical at 25 cSt (120 SUS). Actual data may vary slightly from unit to unit in production.

$\eta_t$  = overall efficiency

Continuous

Intermittent

# Xcel XLS Series (036-)

## Dimensions Xcel XLS Series - Outline

### Standard Rotation Viewed from Shaft End

Port A pressurized – CW

Port B pressurized – CCW

XLS Standard Shaft Seal and Section Seal Kit Number: **Z331-25**

XLS High Pressure Shaft Seal and Section Seal Kit Number: **Z331-59**

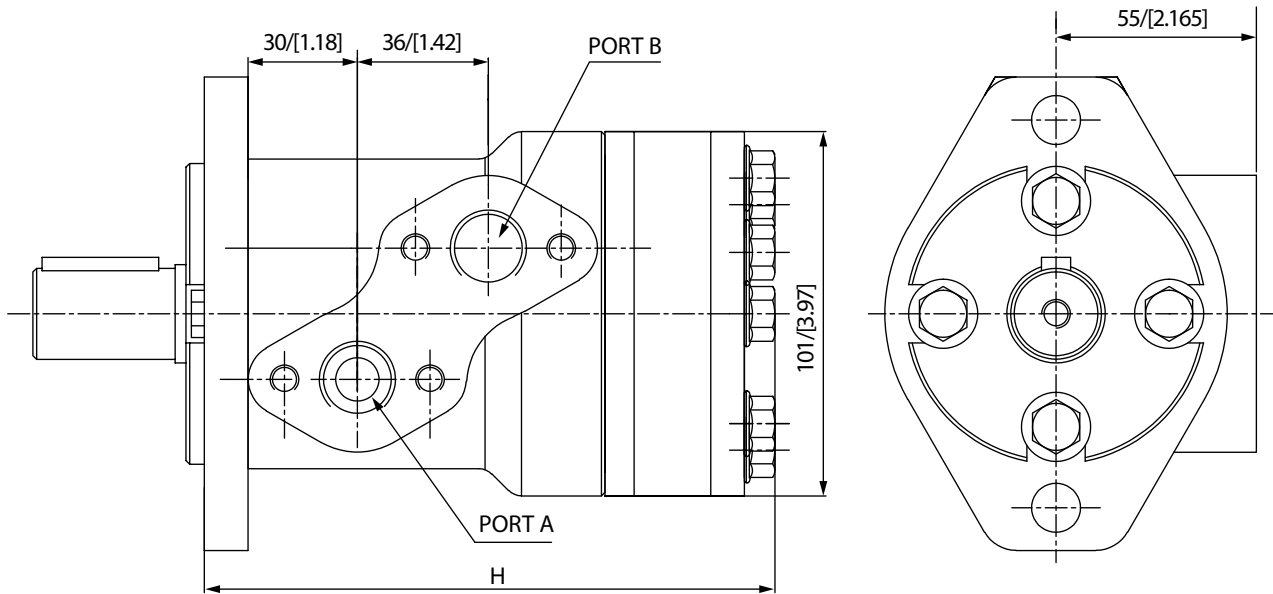

Disp. cc/r [in <sup>3</sup> /r]	50 [3.1]	80 [4.9]	100 [6.2]	130 [8.0]	160 [9.6]	195 [11.9]	245 [14.9]	305 [18.7]	395 [24.0]
H mm [in]	149 [5.86]	156 [6.14]	160 [6.30]	167 [6.57]	167 [6.57]	177 [6.97]	183 [7.59]	194 [7.63]	210 [8.26]

\* Based on the mounting flange SAE A .

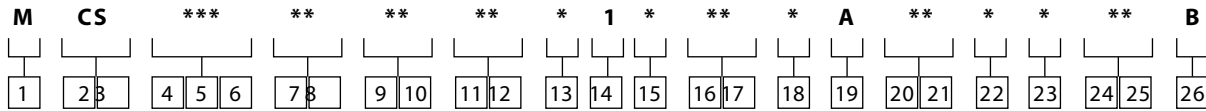

**1 Product**

**M** Motor

**2 3 Series**

**CS** XLS series

**4 5 6 Displacement cm<sup>3</sup>/r [in<sup>3</sup>/r]**

- 050** 50 [3.1]
- 080** 80 [4.9]
- 100** 100 [6.2]
- 130** 130 [8.0]
- 160** 160 [9.6]
- 195** 195 [11.9]
- 245** 245 [14.9]
- 305** 305 [18.7]
- 395** 395 [24.0]

**7 8 Mounting flange**

- AA** 2 bolt SAE A . 82 .55x5, pilot 2-13 .5 Dia . M ounting holes on 106.4 Dia .
- AC** 2 bolt standard, 82 .55x2 .8 pilot . 2-13 .5 Dia . M ounting holes on 106.4 Dia .
- AD** 4 B olt standard, 44 .40 Dia . x 3 .05 pilot . 375-16 UNC-2B . M ounting Holes on 82 .55 Dia . B .C .
- AE** 4 B olt standard . 44 .40 Dia . x 3 .05 pilot, M10x1 .5-6H M ounting Holes on 82 .55 Dia . B .C .

**9 10 Output shaft**

- 1** 25 Dia . Standard straight, parallel key A8x7x32, M 8 hole in shaft end . DIN 6885
- 2** 25 Dia . Straight, 5mm extra length, parallel key A8x7x32, M 8 hole in shaft end . DIN 6885
- 3** 25 .4 Dia . Standard raight, parallel key ¼x¼x1¼, M 8 hole in shaft end . B S 46
- 4** 25 .4 Dia . Splined shaft, SAE6B, .250-20 UNC-2B hole in the shaft end .
- 5** 25 .4 Dia . Straight, parallel key, .250-20 UNC-2B hole in the shaft end .
- 08** 25 .4 Dia . Straight, 10 .3 [ .405] Dia . Cross Hole 15 .7 [.618] from Shaft End, .250-20 UNC-2B hole in the shaft end .

**11 12 Main ports**

- AA** Staggered port 2-G1/2 ISO228/1
- AE** Staggered port 2-0 .875-14UNF-2B O-ring or manifold ports (4-M 8-6H mounting holes)

**13 Case drain options**

- 0** None
- 1** G1/4 ISO228/1
- 3** 0 .4375-20UNF-2B

**14 Geroler options**

- 1** Standard Geroler

**15 Shaft options**

- 0** Standard shaft

**16 17 Seal options**

- 0** Standard seals
- 1** Seal guard
- 2** High pressure seal shaft

**18 Speed sensor options**

- 00** None

**19 Manifold block options**

- A** None

**20 21 Special features (hardware)**

- 00** None

**22 Special assembly instructions**

- 0** None
- 1** Reverse rotation

**23 Paint**

- C** Black primer

**24 25 Customer identification or name plate**

- 00** None

**26 Design code**

- B** Second

# Xcel Spool Valve Motors

## Dimensions - Mounts

### Code AA

SAE A  
2 bolt  
82.55 x 5  
[3.25]x[.196] pilot

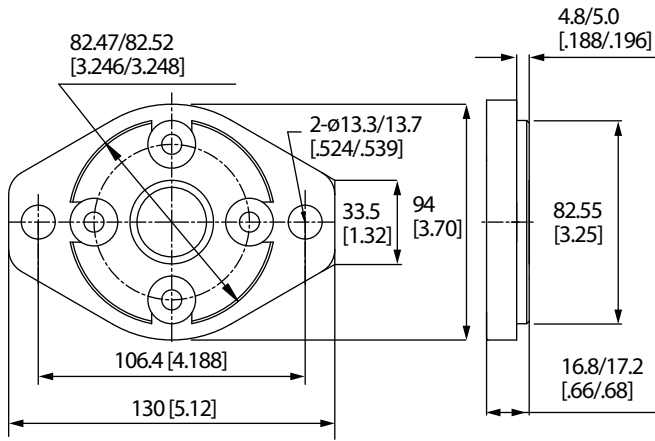

### Code AD

SAE A  
4 bolt  
44.40 [1.748] pilot

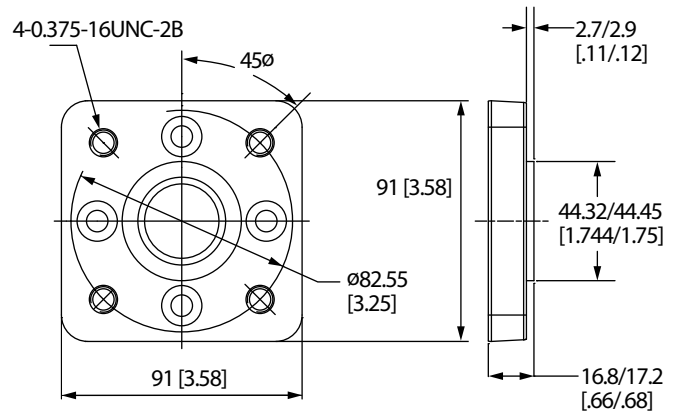

### Code AC

SAE A  
2 bolt  
ø82.55 x 2.5  
[3.25]x[.110]

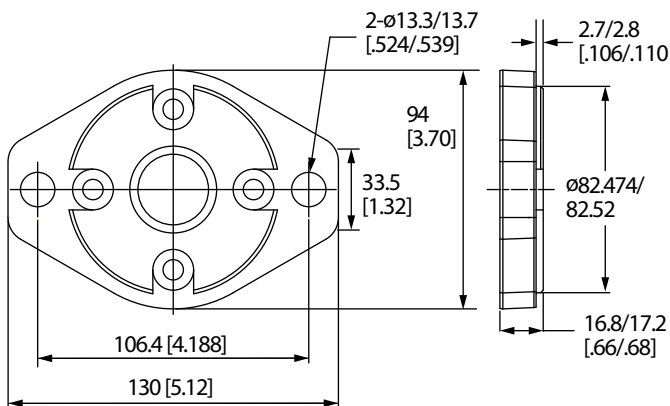

### Code AE

SAE A  
4 bolt  
44.40 [1.748] pilot  
Metric

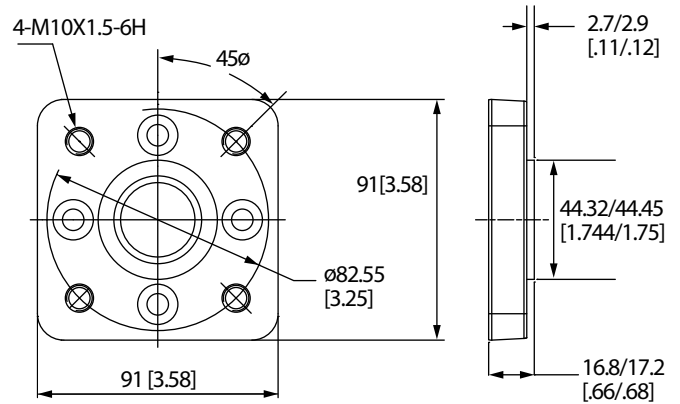

SAE 6B splined shaft (Code 04) recommended whenever operation above 260Nm [2300 in-lb] of torque, especially for those applications subject to frequent reversals .

### 25mm Straight Shaft (01)

395Nm [3500 in-lb] M ax . torque

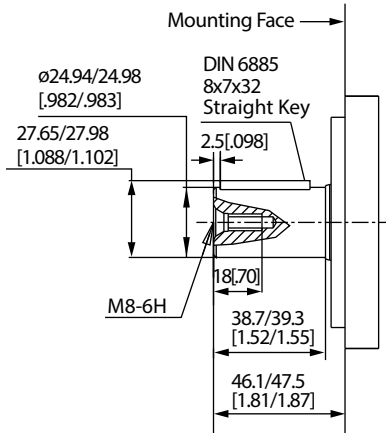

### Straight Shaft (03)

395Nm [3500 in-lb] M ax . torque

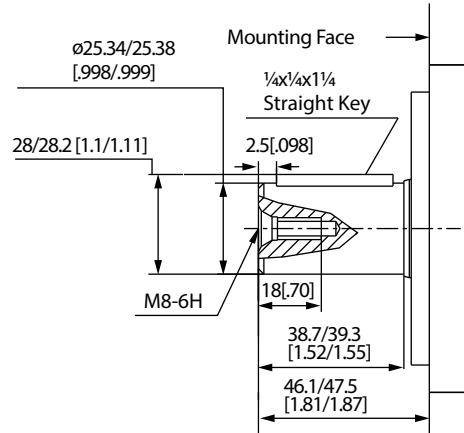

### 25 mm Straight Shaft w/ 5mm extra length (02)

395Nm [3500 in-lb] M ax . torque

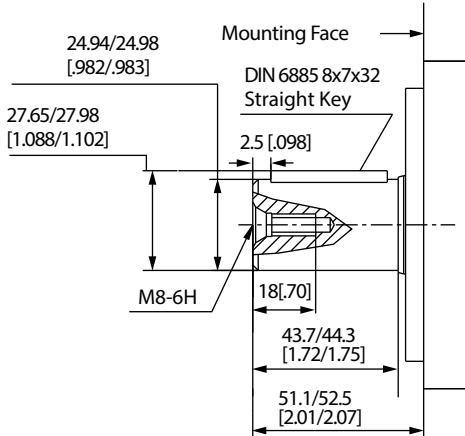

### SAE 6B Spline (04)

395Nm [3500 in-lb] M ax . torque

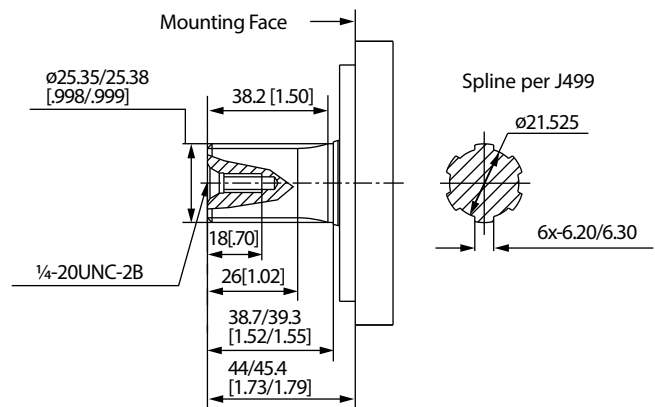

### 25.4 [1.00] Straight Shaft (05)

395Nm [3500 in-lb] M ax . torque

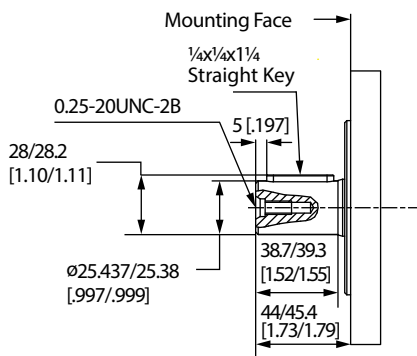

### 25.4 [1.00] Straight Shaft w/ Crosshole (08)

338Nm [3000 in-lb] M ax . torque

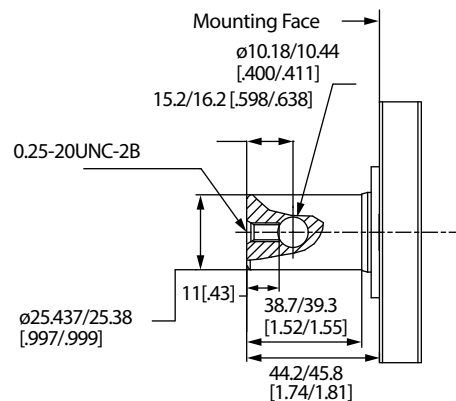

# Xcel Spool Valve Motors

Dimensions - Ports

## Code AA

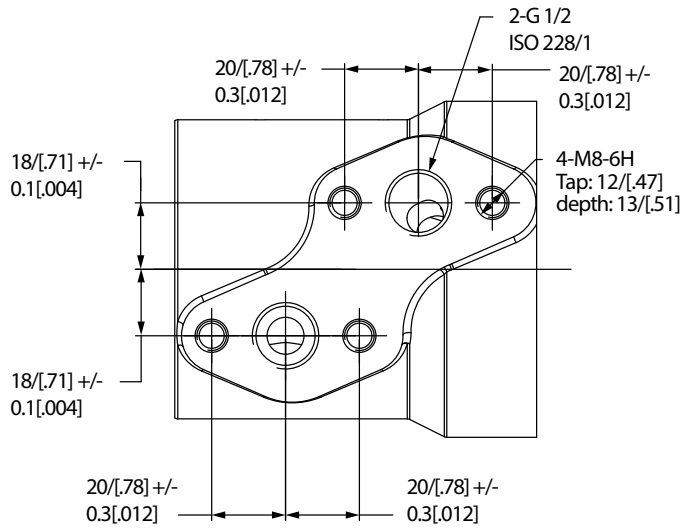

## Code AE

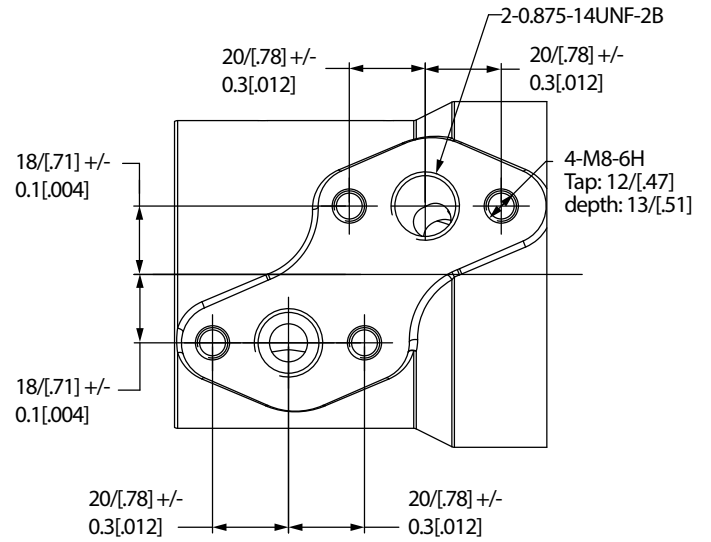



# Xcel Spool Valve Motors

## Shaft Side Load Capacity and Case Pressure

$$\text{Side Load } P \text{ (Kg)} = \frac{800}{N} \left( \frac{15000}{L+100} \right) \text{ from 200-800 RPM}$$

Where N = Shaft Speed (RPM)

L = Distance from Mounting Surface (mm)

P = Side Load (Kg)

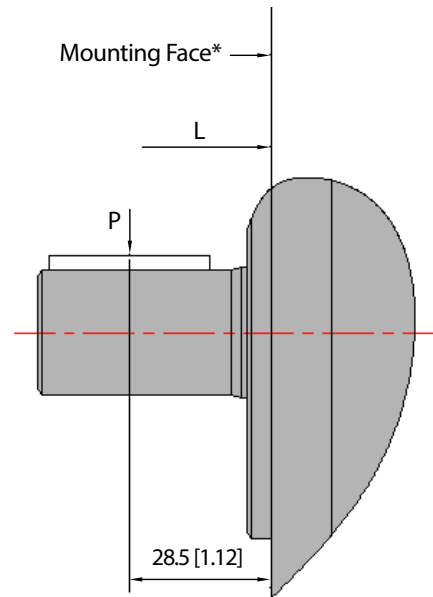
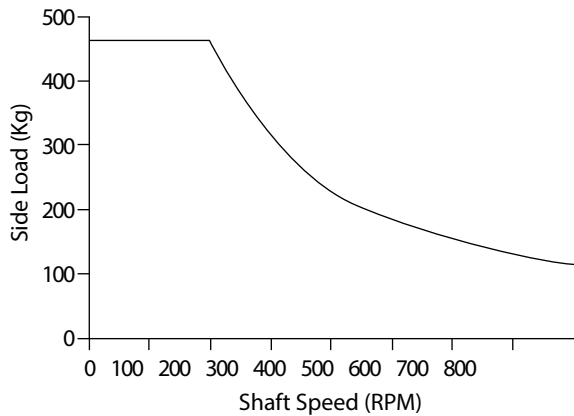

### Case Pressure/Shaft Seal

Refer to the case pressure/shaft seal chart below. Allowable case pressure is highest at low shaft speeds. Motor life will be shortened if case pressure exceeds recommended ratings.

Case pressure is as follows:

$$P_c = 0.6\Delta P + P_2 \quad \Delta P = P_1 - P_2$$

$P_c$  = Case Pressure,

$P_1$  = Inlet Line Pressure

$P_2$  = Outlet Pressure

The motor life is improved from use of a case drain line.

- Contamination control – flushing the motor case
- Motor cooler – exiting oil draws motor heat away.
- Extend motor seal life – maintain low case pressure with a preset restriction installed in the case drain line.

When case drain line is used, make sure the motor is always filled with oil.

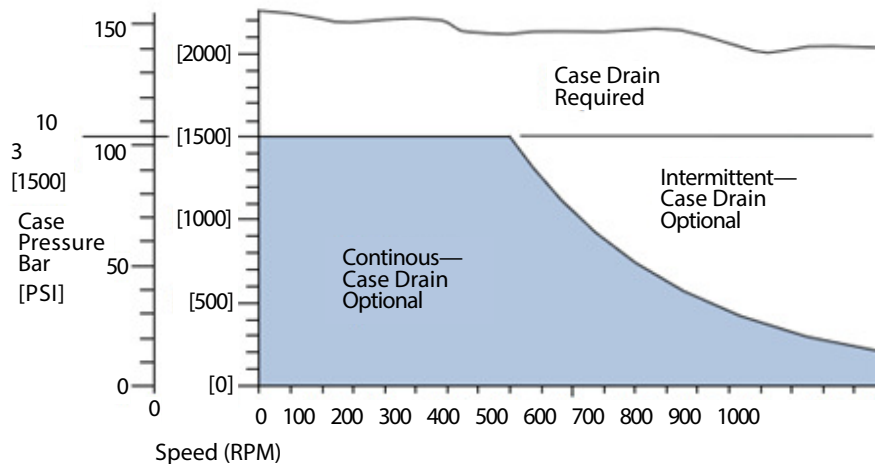

Case Pressure Seal Limitation

### XLS Series Only

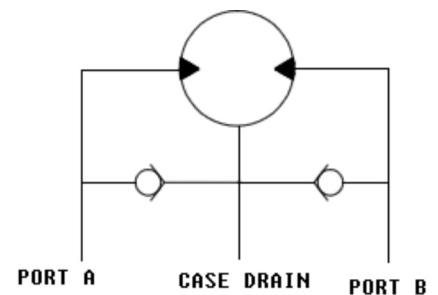

**Note:** With check valves as standard on the XLS motor, case pressure can be considered the same as the outlet pressure/backpressure.

**Note:** Check Valves are not available on the XLH Series.

# XL2 Series

## Highlights



## Description

Danfoss' Xcel™ Series Low Speed High Torque Disc Valve motors offer the most popular features and options from the parallel Danfoss Char-Lynn range and are optimized to bring the highest value in medium duty applications .

### Features

- Three zone design for longer life and true bi-directionality
- Bearings that meet the highest standards of the industry
- Options to optimize performance in every application
- Integrated cross-over relief and counterbalance valve options

### Benefits

- Easy to design in a system
- Reliability in multiple applications
- Integrated valve options to minimize installed size and weight

### Applications

- Skid steer attachments
- Swing motor
- Brush Cutters & Mowers

- Augers
- Sweepers
- Snow blowers
- Conveyors

### XL2 Series Motors

Geroler® element	9 displacements
Flow LPM[GPM]	75 [20] Continuous*
	115 [30] Intermittent **
Speed RPM	908 Cont.*
	924 Inter **
Pressure Bar [psi]	205[3000] Cont.*
	310 [4500] Inter **
Torque Nm [lb-in]	845 [7470] Cont.*
	930 [8225] Inter **

\* Continuous-(Cont.) Continuous rating, motor may be run continuously at these ratings

\*\* Intermittent-(Inter.) Intermittent operation, 10% of every minute

# XL2 Series

## Specifications

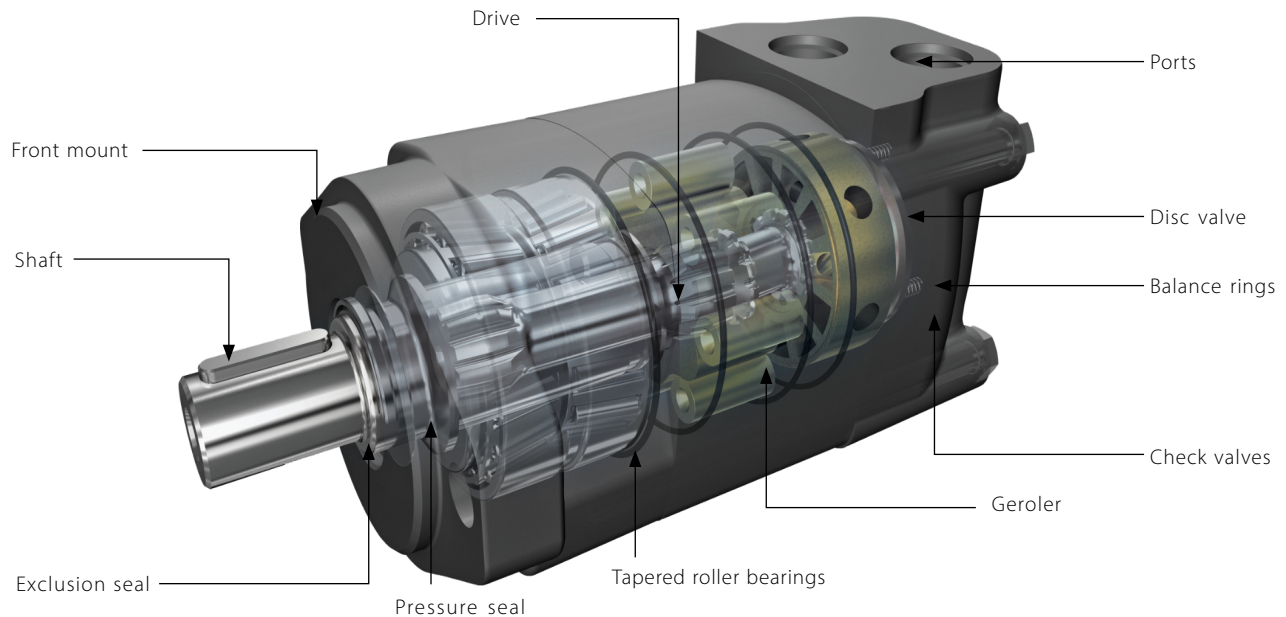

### Specification Data

Displacement cm <sup>3</sup> /r [in <sup>3</sup> /r]		80 [4.9]	100 [6.1]	130 [7.9]	160 [9.8]	195 [11.9]	245 [15]	305 [18.6]	395 [24.1]	490 [29.9]
Flow LPM [GPM]	Continuous	75 [20]	75 [20]	75 [20]	75 [20]	75 [20]	75 [20]	75 [20]	75 [20]	75 [20]
	Intermittent	75 [20]	95 [25]	95 [25]	115 [30]	115 [30]	115 [30]	115 [30]	115 [30]	115 [30]
Speed RPM	Continuous	908	739	575	477	385	308	246	191	153
	Intermittent	908	924	719	713	577	462	365	287	230
Pressure ΔBar [Δpsi]	Continuous	205 [3000]	205 [3000]	205 [3000]	205 [3000]	205 [3000]	205 [3000]	205 [3000]	155 [2248]	120 [1740]
	Intermittent	310 [4500]	310 [4500]	310 [4500]	260 [3771]	260 [3771]	260 [3771]	240 [3481]	170 [2466]	140 [2031]
Torque* Nm [lb-in]	Continuous	235 [2080]	295 [2611]	385 [3407]	455 [4027]	540 [4779]	660 [5841]	765 [6770]	775 [6859]	845 [7478]
	Intermittent	345 [3053]	445 [3938]	560 [4956]	570 [5045]	665 [5885]	820 [7257]	885 [7832]	925 [8186]	930 [8231]
Weight Kg [lbs]	Standard or wheel mont	9.3 [20.5]	9.5 [20.9]	9.8 [21.6]	10.0 [22]	10.4 [22.9]	10.9 [24]	11.3 [24.9]	11.8 [26]	12.2 [26.9]
	Bearingless	7.3 [16.1]	7.5 [16.5]	7.7 [17]	7.9 [17.4]	8.4 [18.5]	8.8 [19.4]	9.3 [20.5]	9.8 [21.6]	10.2 [22.5]

Maximum Case Pressure: See case pressure seal limitation graph

\*See shaft torque ratings for limitations .

**Note:** To assure best motor life, run motor for approximately one hour at 30% of rated pressure before application to full load . Be sure motor is filled with fluid prior to any load applications .

#### Max. inlet pressure:

310 bar [4500 psi]

Do not exceed Δ pressure rating (see chart above)

#### Max. return pressure:

310 bar [4500 psi] with case drain line installed

Do not exceed Δ pressure rating (see chart above)

#### ΔBar[Δpsi]:

The true pressure difference between inlet port and outlet port

#### Continuous rating:

Motor may be run continuously at these ratings

#### Intermittent operation:

10% of every minute

#### Recommended fluids:

Premium quality anti-wear type hydraulic oil with a viscosity of not less than 13 cSt (70 SUS) at operating temperature .

#### Recommended system operating temp.:

-34oC to 82oC [-30oF to 180oF]

#### Recommended filtration

Per ISO Cleanliness code, 4406:20/18/13

# XL2 Series

## Performance Data

Function Diagram: XL2 motor 80 cc

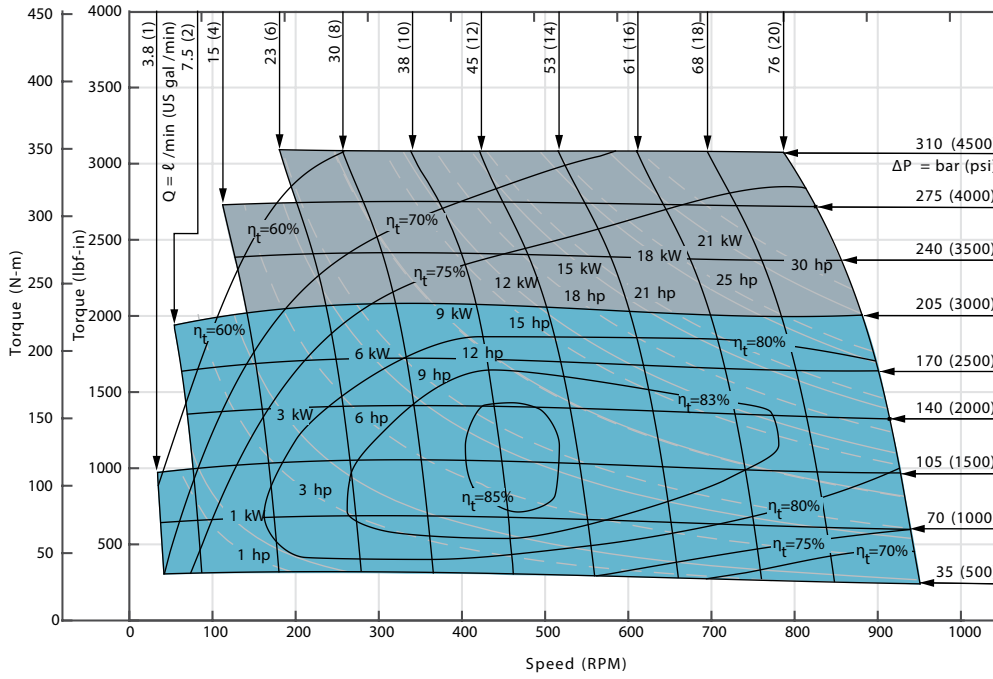

Performance data is typical at 25 cSt (120 SUS). Actual data may vary slightly from unit to unit in production.

$\eta_t$  = overall efficiency

- Continuous
- Intermittent

Function Diagram: XL2 motor 100 cc

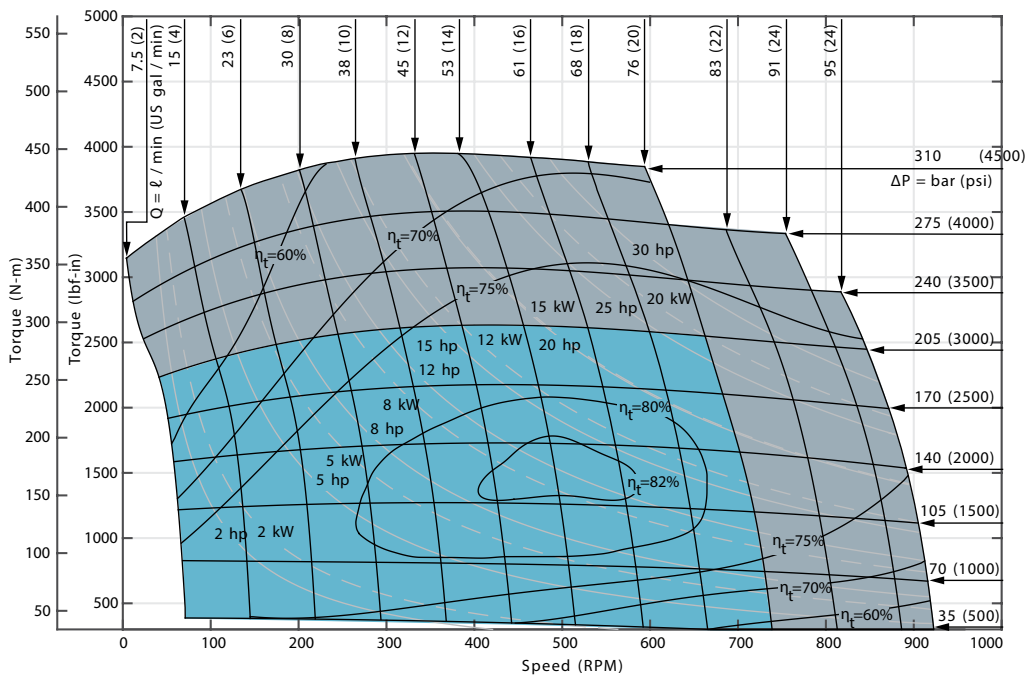

# XL2 Series

## Performance Data

Function Diagram: XL2 motor 130 cc

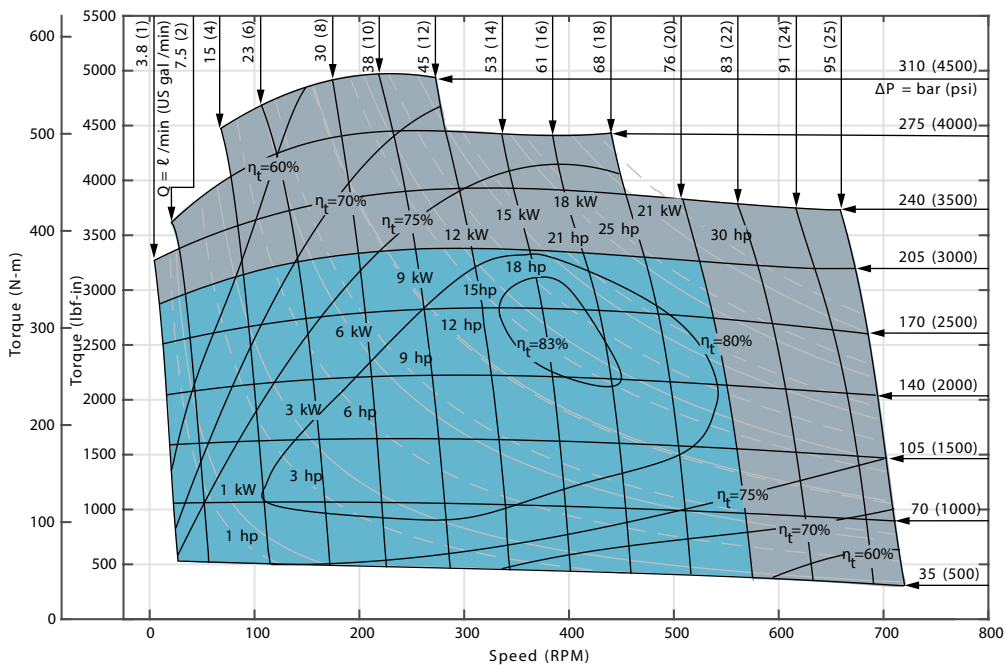

Performance data is typical at 25 cSt (120 SUS). Actual data may vary slightly from unit to unit in production.

$\eta_t$  = overall efficiency

- Continuous
- Intermittent

Function Diagram: XL2 motor 160 cc

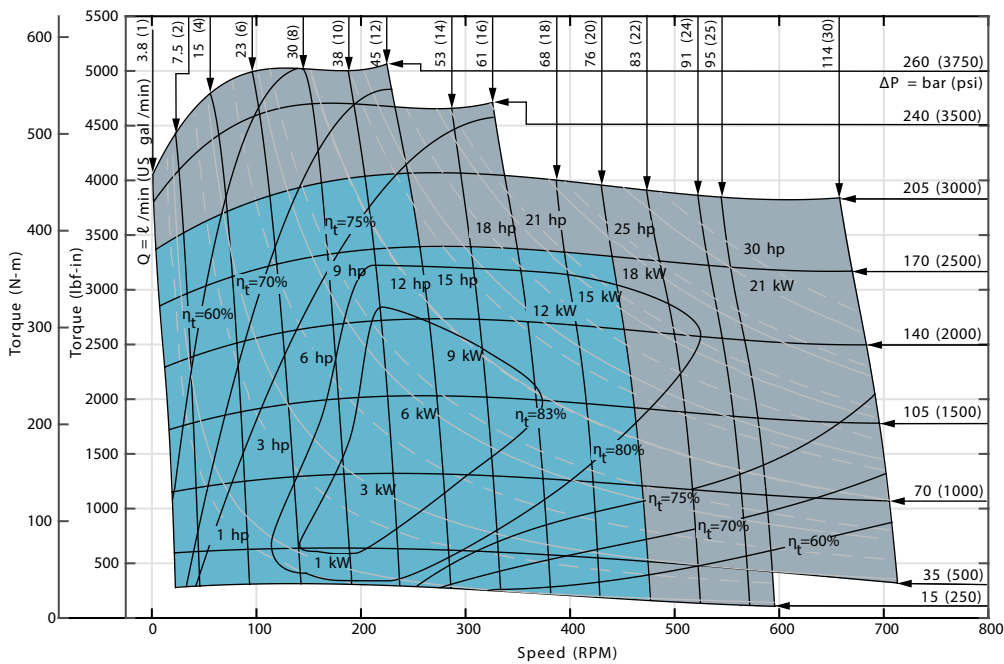

# XL2 Series

## Performance Data

Function Diagram: XL2 motor 195 cc

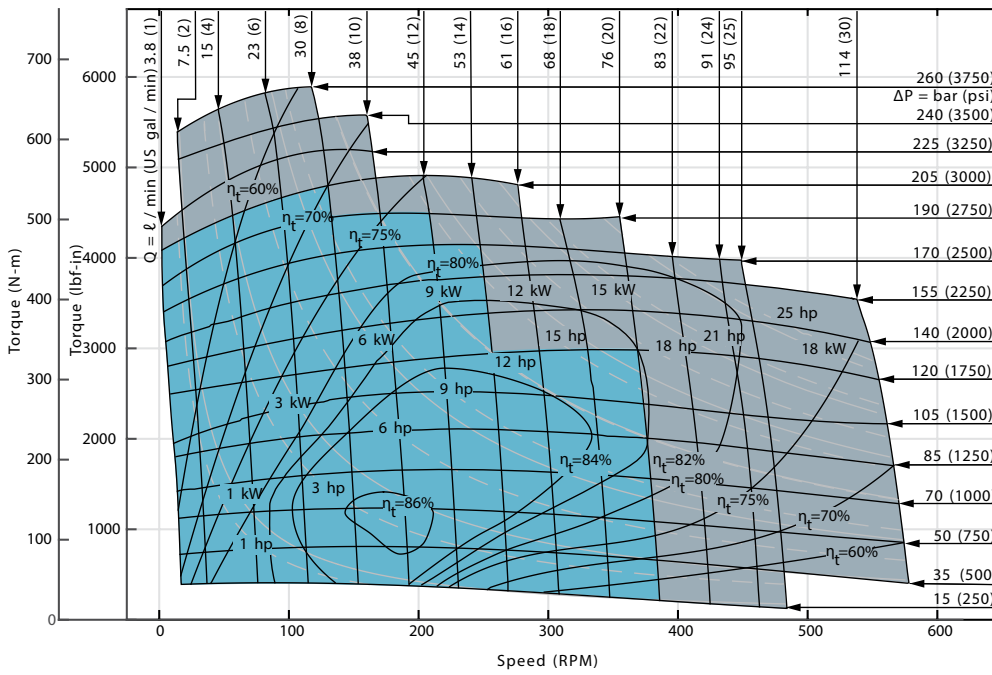

Performance data is typical at 25 cSt (120 SUS). Actual data may vary slightly from unit to unit in production.

$\eta_t$  = overall efficiency

- Continuous
- Intermittent

Function Diagram: XL2 motor 245 cc

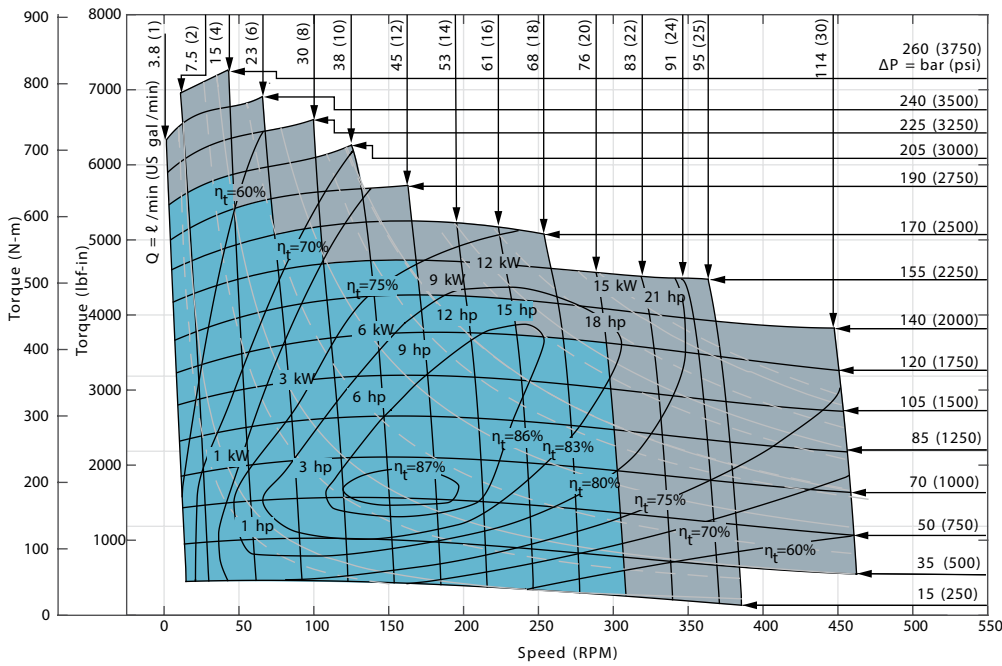

# XL2 Series

## Performance Data

Function Diagram: XL2 motor 305 cc

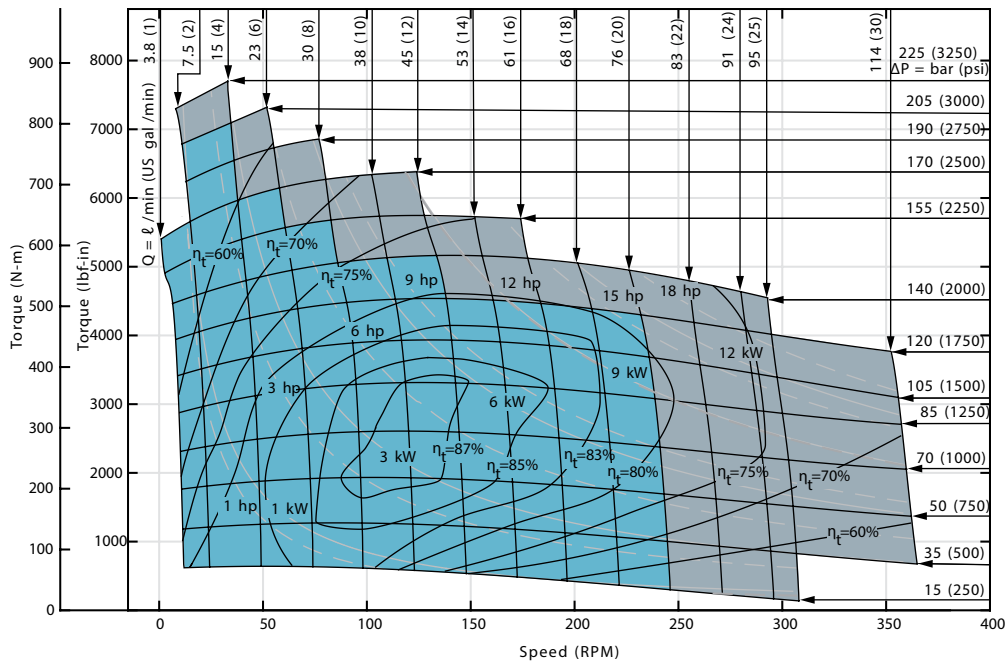

Performance data is typical at 25 cSt (120 SUS). Actual data may vary slightly from unit to unit in production.

$\eta_t$  = overall efficiency

Continuous

Intermittent

Function Diagram: XL2 motor 395 cc

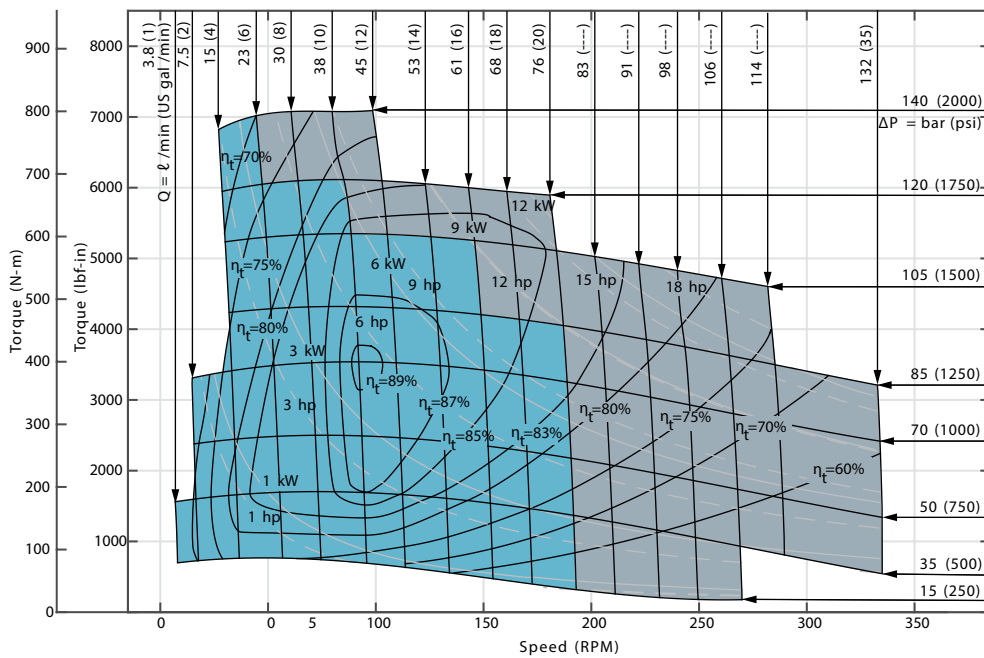

# XL2 Series

## Performance Data

Function Diagram: XL2 motor 490 cc

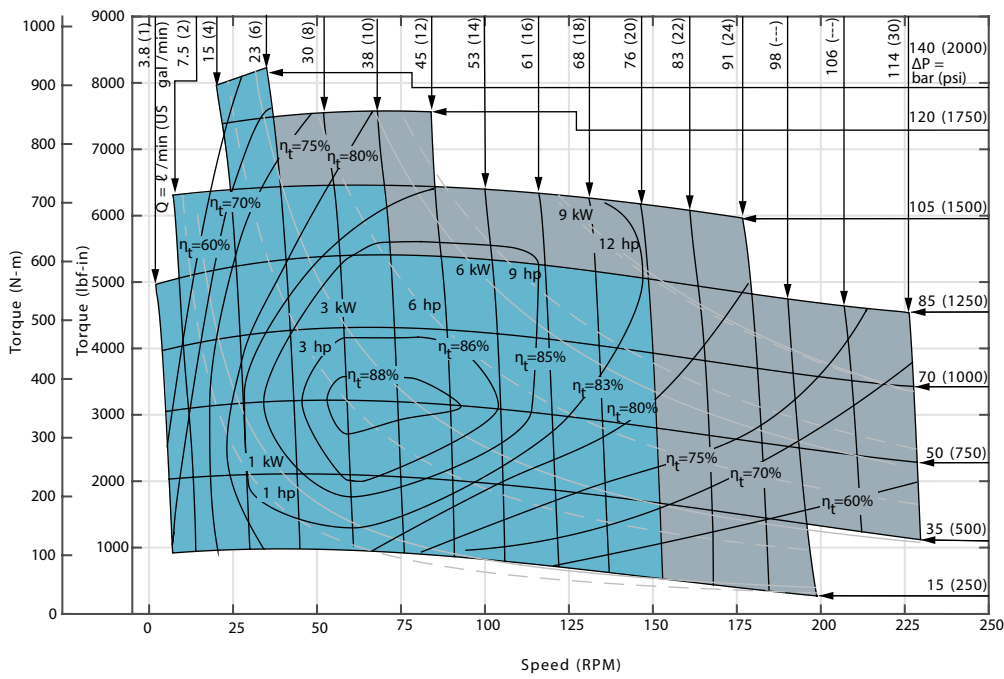

Performance data is typical at 25 cSt (120 SUS). Actual data may vary slightly from unit to unit in production.

$\eta_t$  = overall efficiency

Continuous

Intermittent



### Standard Rotation Viewed from Shaft End

Port A pressurized – CW

Port B pressurized – CCW

XL2 Standard and W heel mount Shaft Seal and Section Seal Kit Number: **Z331-02**

XL2 Standard and W heel mount High Pressure Shaft Seal and Section Seal Kit Number: **Z331-51**

XL2 Standard and W heel mount High Pressure Shaft Seal, Seal Guard, and Section Seals Kit Number: **Z331-45**

### Standard Mount & Wheel Mount

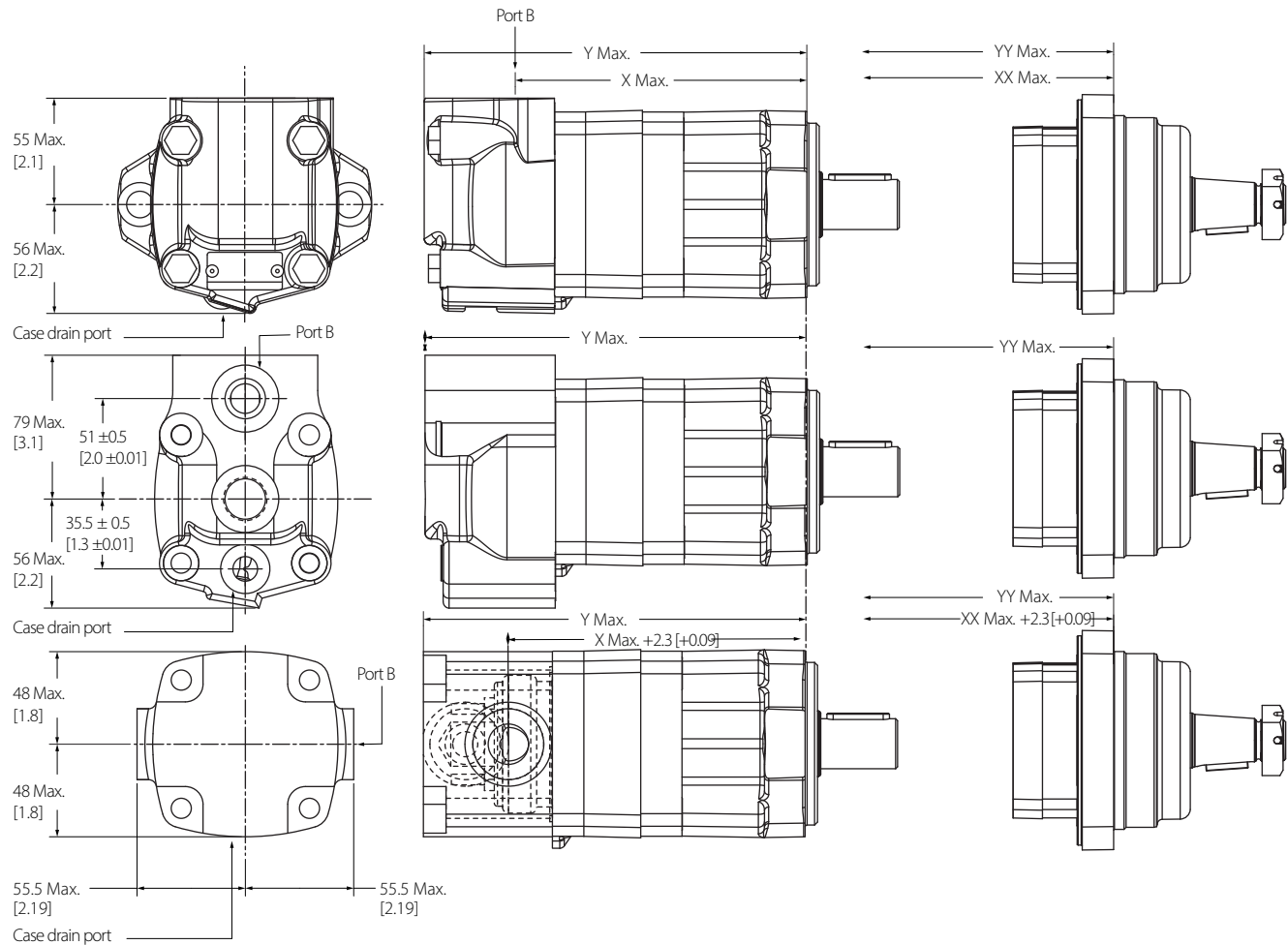

Standard/wheel mount motor		dimensions			
Displacement	X	Y	XX	YY	
cm <sup>3</sup> / r [in <sup>3</sup> / r]	mm [inch]	mm [inch]	mm [inch]	mm [inch]	
80 [4.9]	136.9 [5.39]	184.2 [7.25]	96.9 [3.81]	144.3 [5.68]	
100 [6.1]	141.5 [5.57]	189 [7.44]	101.4 [3.99]	148.9 [5.86]	
130 [7.9]	147.9 [5.82]	195.4 [7.69]	107.8[4.24]	155.2 [6.11]	
160 [9.8]	147.9 [5.82]	195.4 [7.69]	107.8[4.24]	155.2 [6.11]	
195 [11.9]	154.7 [6.09]	202.2 [7.96]	114.6[4.51]	162.1 [6.38]	
245 [15]	163.7 [6.44]	211.1 [8.31]	123.5[4.86]	171 [6.73]	
305 [18.6]	175.1 [6.89]	222.3 [8.75]	135[5.31]	182.4 [7.18]	
395 [24.1]	191 [7.52]	238.6 [9.39]	151.5[5.96]	198.4 [7.81]	
490 [29.9]	208.4 [8.2]	255.8 [10.07]	168.2[6.62]	215.7 [8.49]	

# XL2 Series

Dimensions Standard/Wheel Mount with Integral Valve

## Standard Rotation Viewed from Shaft End

Port A pressurized – CW

Port B pressurized – CCW

## Standard Mount with Integral Valve & Wheel Mount with Integral Valve

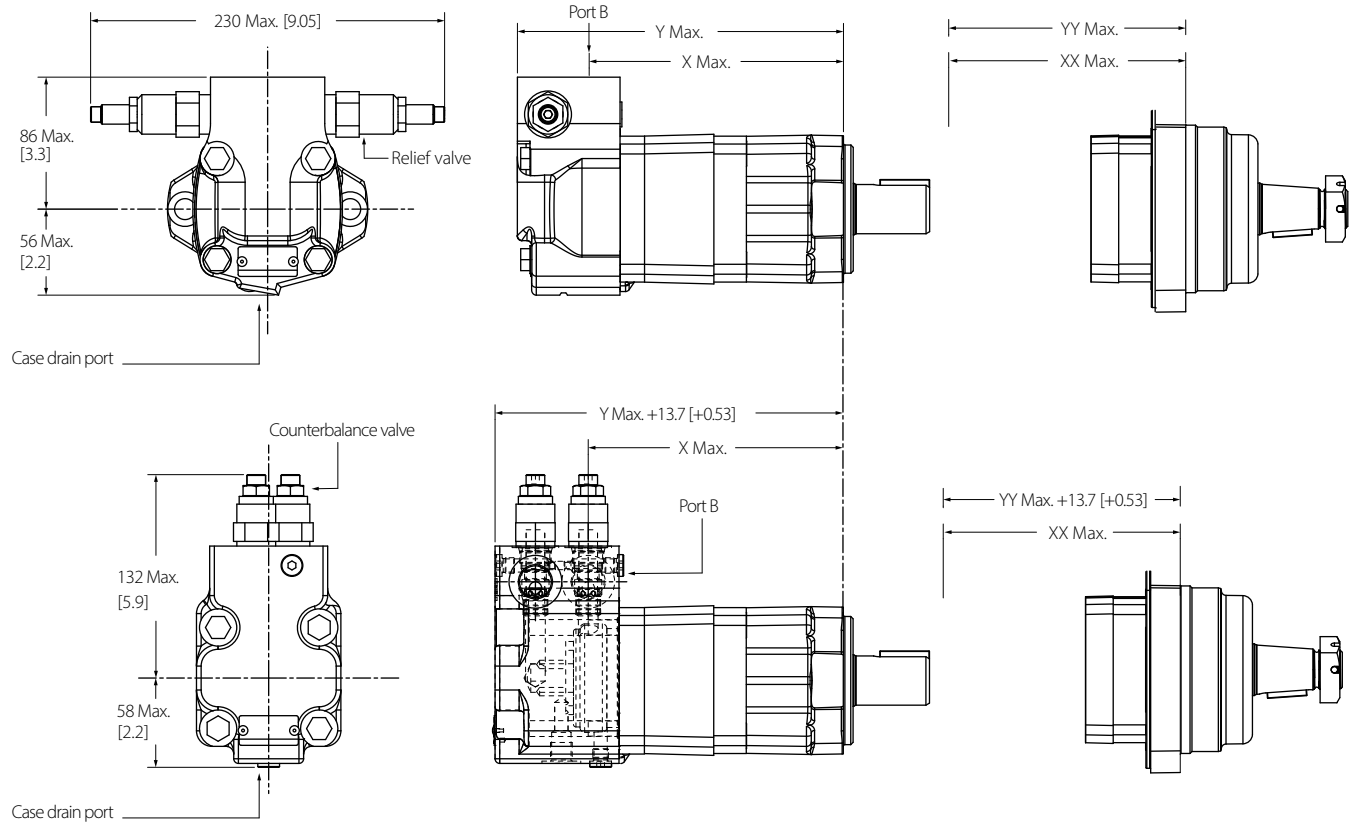

## Functional symbol

### Relief valve

RV3A-10-S -O-36 or

CRV2-10-C-0-0-30

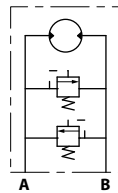

### Counterbalance valve

1CE30

(Rated Flow 30LPM)

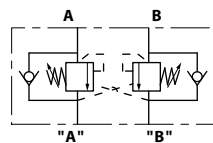

**Note:** Please contact Danfoss for more detailed information about relief valve and counterbalance valve

Standard/wheel mount motor		dimensions			
Displacement	X	Y	XX	YY	
cm <sup>3</sup> / r [in <sup>3</sup> / r]	mm [inch]	mm [inch]	mm [inch]	mm [inch]	mm [inch]
80 [4.9]	136.9 [5.39]	184.2 [7.25]	96.9 [3.81]	144.3 [5.68]	
100 [6.1]	141.5 [5.57]	189 [7.44]	101.4 [3.99]	148.9 [5.86]	
130 [7.9]	147.9 [5.82]	195.4 [7.69]	107.8 [4.24]	155.2 [6.11]	
160 [9.8]	147.9 [5.82]	195.4 [7.69]	107.8 [4.24]	155.2 [6.11]	
195 [11.9]	154.7 [6.09]	202.2 [7.96]	114.6 [4.51]	162.1 [6.38]	
245 [15]	163.7 [6.44]	211.1 [8.31]	123.5 [4.86]	171 [6.73]	
305 [18.6]	175.1 [6.89]	222.3 [8.75]	135 [5.31]	182.4 [7.18]	
395 [24.1]	191 [7.52]	238.6 [9.39]	151.5 [5.96]	198.4 [7.81]	
490 [29.9]	208.4 [8.2]	255.8 [10.07]	168.2 [6.62]	215.7 [8.49]	

### Standard rotation viewed from shaft end

Port A pressurized – CW

Port B pressurized – CCW

### Bearingless

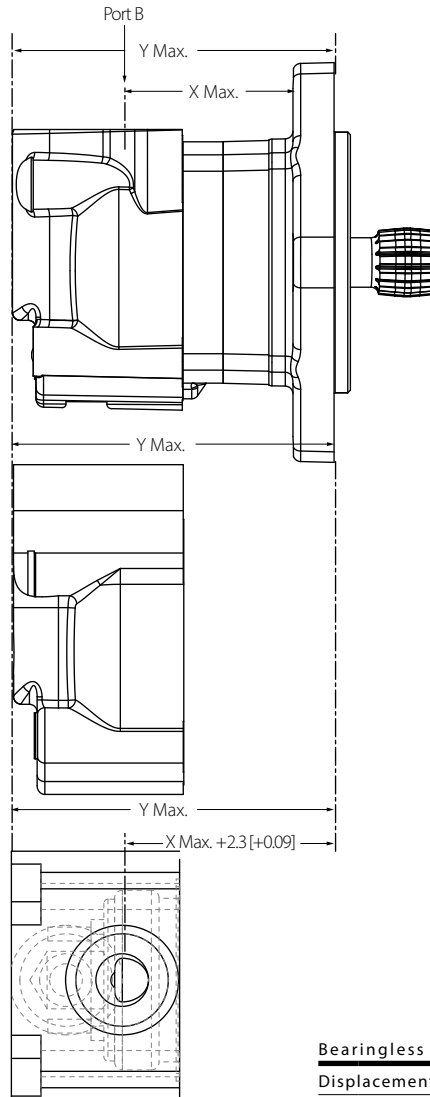
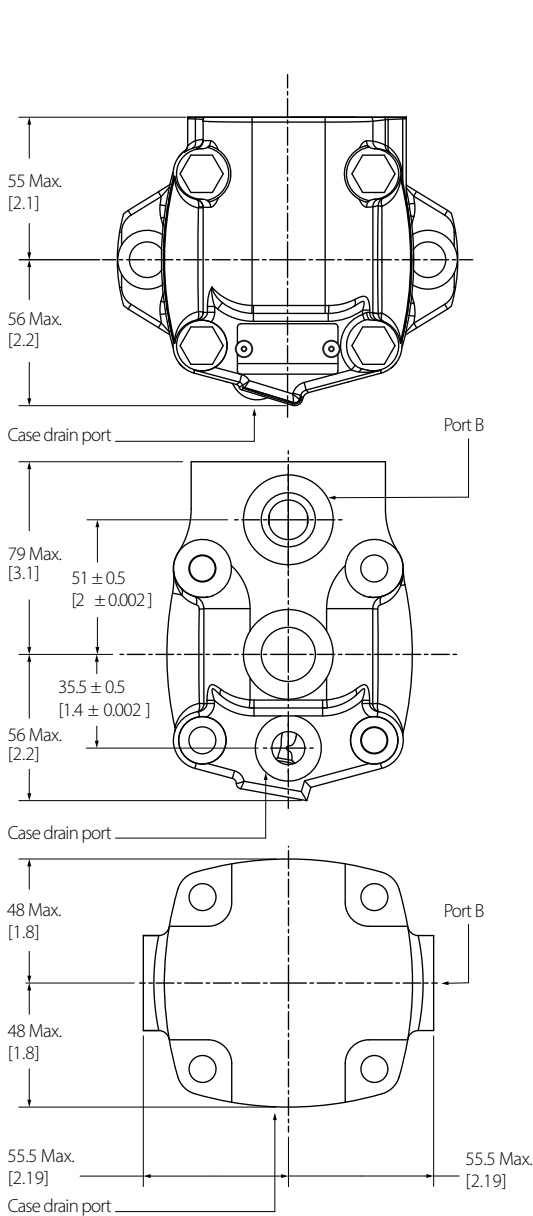

**Bearingless mount motor dimensions**

Displacement cm <sup>3</sup> / r [in <sup>3</sup> / r]	X		Y	
	mm	[inch]	mm	[inch]
80 [4.9]	79	[3.11]	126.5	[4.98]
100 [6.1]	83.5	[3.29]	131.4	[5.17]
130 [7.9]	89.9	[3.54]	137.7	[5.42]
160 [9.8]	89.9	[3.54]	137.7	[5.42]
195 [11.9]	96.8	[3.81]	144.3	[5.68]
245 [15]	105.6	[4.16]	153.5	[6.04]
305 [18.6]	117.1	[4.61]	164.6	[6.48]
395 [24.1]	133.1	[5.24]	180.9	[7.12]
490 [29.9]	150.3	[5.92]	198.2	[7.8]

# XL2 Series

## Dimensions Bearingless

### Bearingless Mount (AD)

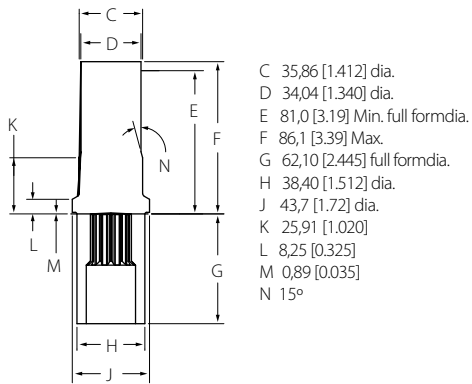
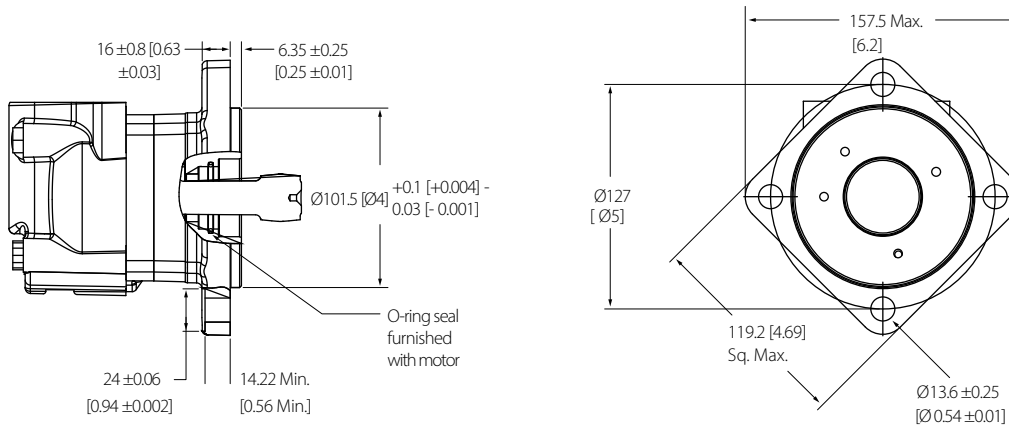

Mating coupling blank  
Danfoss part no. 6034897-803

For Xcel XL2 Series Bearingless Motor application information contact your Danfoss representative (mating coupling blanks available from Danfoss).

**Note:**

After machining blank, part must be hardened per Danfoss specification

## Standard rotation viewed from shaft end

Port A pressurized – CW  
 Port B pressurized – CCW

## Bearingless with Integral Valve

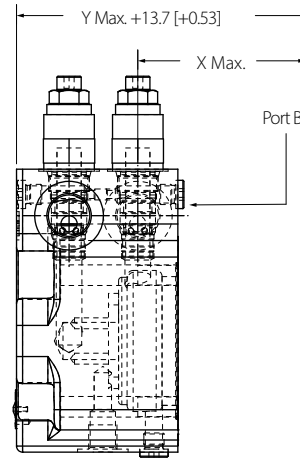
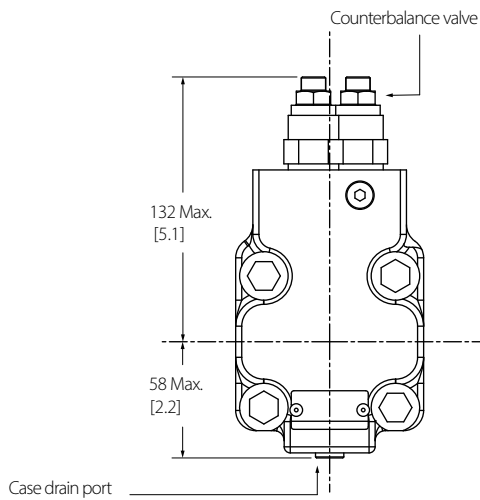
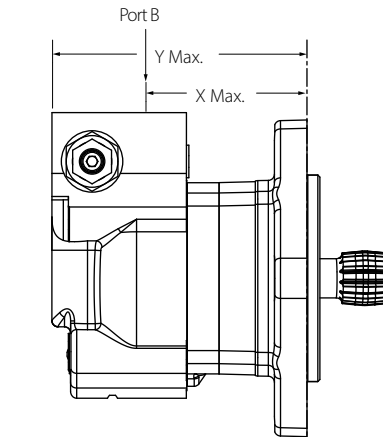
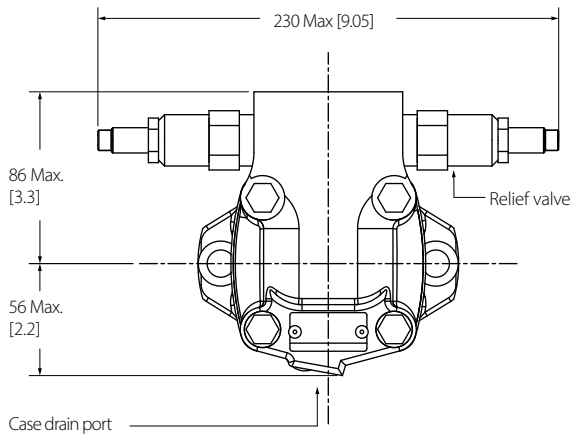

## Relief valve

RV3A-10-S -O-36 or  
 CRV2-10-C-0-0-30

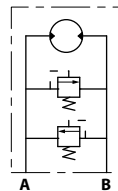

## Counterbalance valve

1CE30

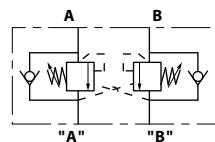

## Bearingless mount motor dimensions

Displacement cm <sup>3</sup> /r [in <sup>3</sup> /r]	X mm [inch]	Y mm [inch]
80 [4.9]	79 [3.11]	126.5 [4.98]
100 [6.1]	83.5 [3.29]	131.4 [5.17]
130 [7.9]	89.9 [3.54]	137.7 [5.42]
160 [9.8]	89.9 [3.54]	137.7 [5.42]
195 [11.9]	96.8 [3.81]	144.3 [5.68]
245 [15]	105.6 [4.16]	153.5 [6.04]
305 [18.6]	117.1 [4.61]	164.6 [6.48]
395 [24.1]	133.1 [5.24]	180.9 [7.12]
490 [29.9]	150.3 [5.92]	198.2 [7.8]

# XL2 Series

## Installation Information Bearingless

- ① Internal spline in mating part to be per spline data. Specification material to be ASTM A304, 8620H vacuum degassed alloy steel carbonize to a hardness of 59-62 HRC with case depth (to 50HRC) of 0,076 -1,02 [.030 -.040]. Dimensions apply after heat treat.
- ② Mating part to have critical dimensions as shown. Oil holes must be provided and open for proper oil circulation.
- ③ Seal to be furnished with motor for proper oil circulation thru splines.
- ④ Some means of maintaining clearance between shaft and mounting flange must be provided.
- ⑤ Counterbore designed to adapt a standard sleeve bearing 35,010 -35,040 [1.3784 -1.3795] I.D. by 44,040 -44,070 [1.7339 -1.7350] O.D. (Oilite Bronze Sleeve Bearing AAM3544-22).

### Bearingless

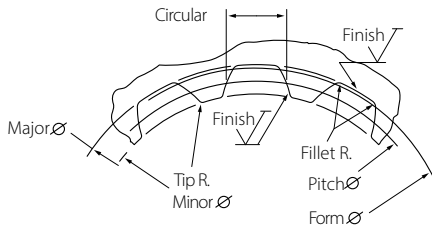
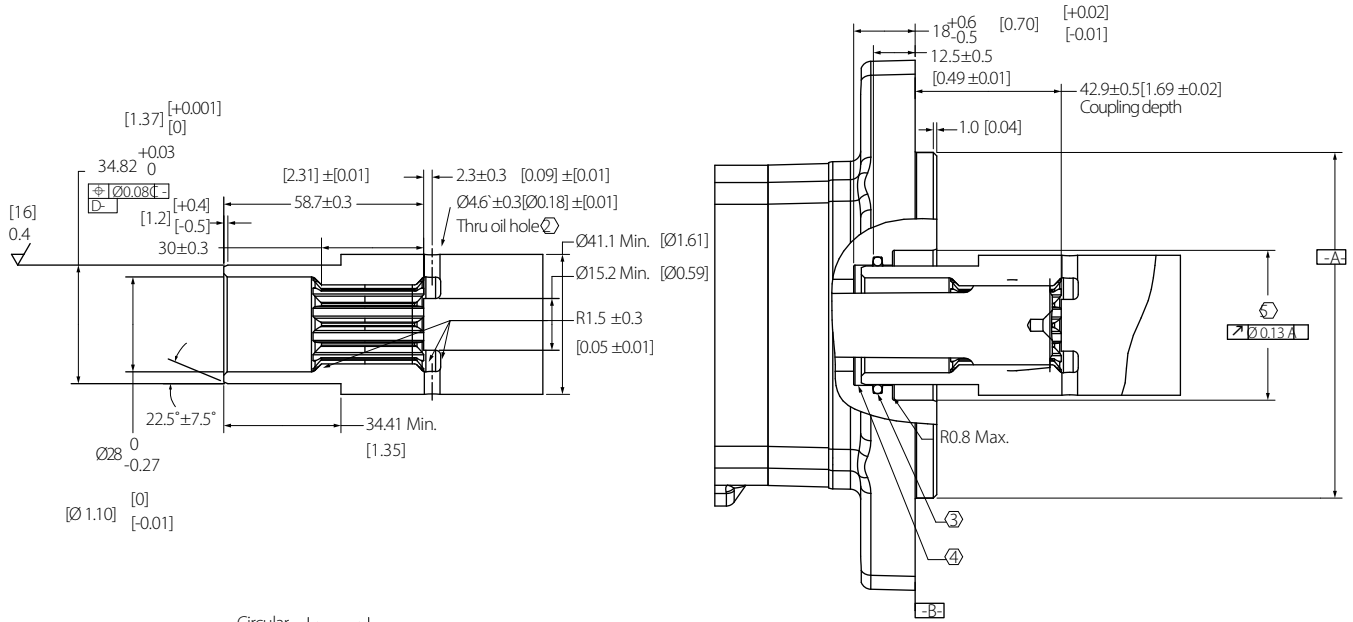

Spline pitch	12/24
Pressure angle	30°
Number of teeth	12
Class of fit	Ref 5
Type of fit	Side
Pitch diameter	Ref. 25,400000 [1.0000000]
Base diameter	Ref. 21,997045 [.8660254] $\text{Ⓢ}0,21 [0.008]   D$
Major diameter	(27,74 [1.092] Max. 27,59 [1.086] Min.)
Minor diameter	23,097 - 23,224 [.9093 - .9143]
Form diameter, min	29,93 [1.060]
Fillet radius	0,64 - 0,76 [.025 - .030]
Tip radius	0,25 - 0,38 [.010 - .015]
Finish	1,6 (63)
Involute profile variation	+0,000 -0,025 [+0.0000 -0.010]
Total index variation	0,038 [.0015]
Lead variation	0,013 [.0005]
Circular space width:	
Maximum actual	4,318 [1.700]
Minimum effective	4,216 [1.660]
Maximum effective	Ref. 4,270 [1.681]
Minimum actual	Ref. 4,247 [1.672]
Dimension between two pins	Ref. 19,020 - 19,190 [.7488 - .7555]
Pin diameter	4,496 [1.770] Pins to Have 3,38 [.133] Wide flat for root clearance

### SAE A - Two Bolt (AC)

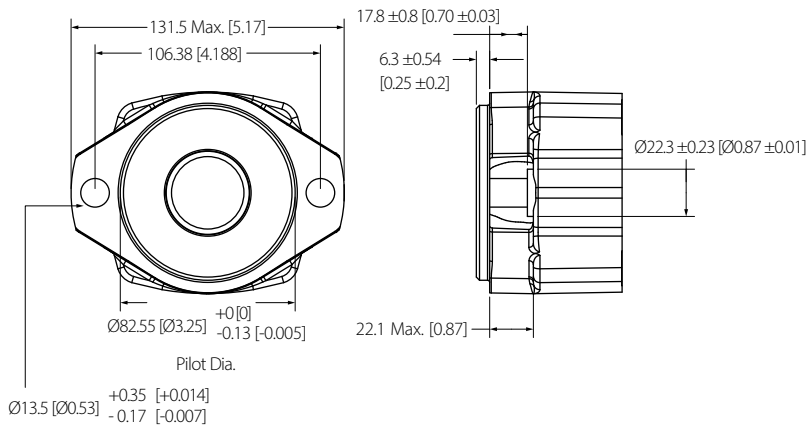

### Four Bolt Wheel (AB)

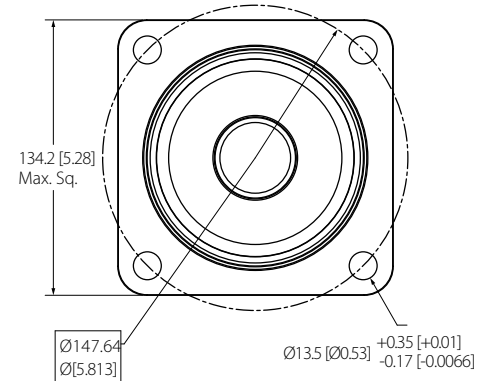

### Four Bolt (AH)

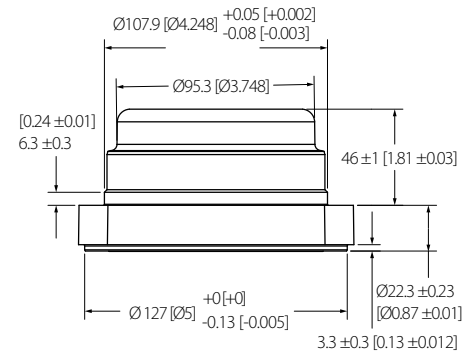
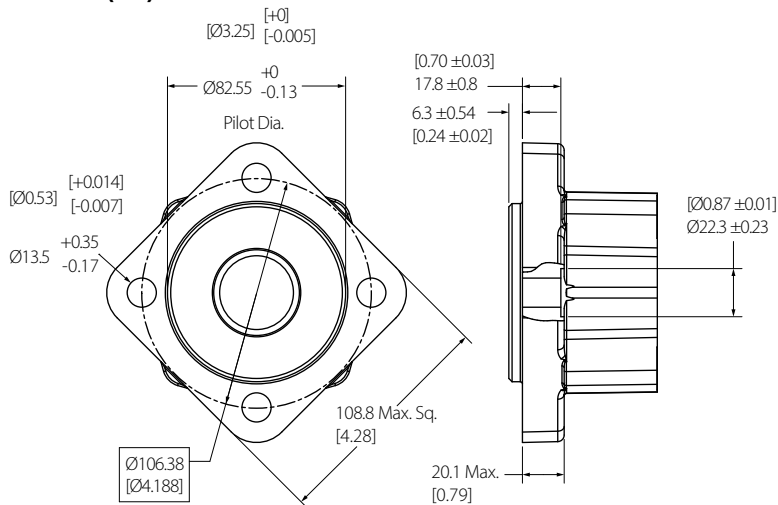

### Four Bolt Magneto (AJ)

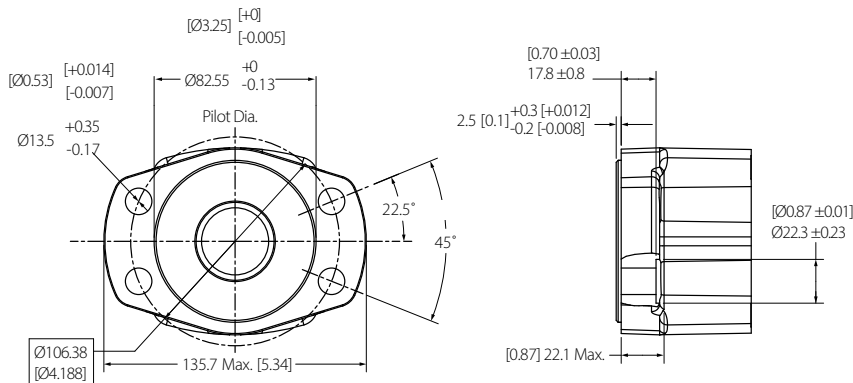

# XL2 Series

## Dimensions Shafts

### 25.4mm Straight (01)

395Nm [3500 in-lb] Max. torque

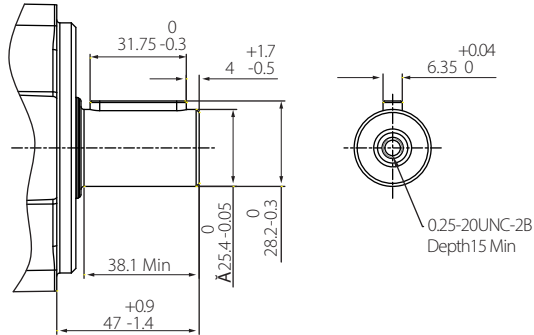

### 31.75 [1.25] Straight (02)

768Nm [6800 in-lb] Max. torque

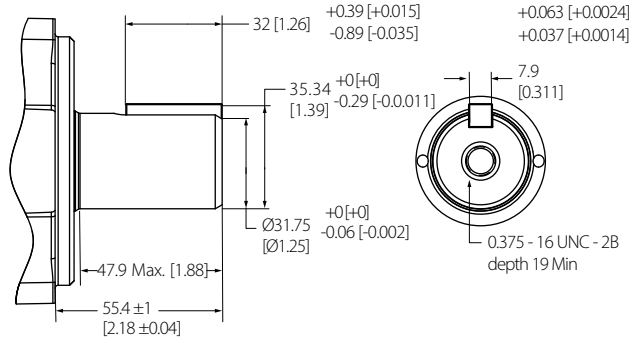

### 31.75 [1.25] Tapered (03)

768Nm [6800 in-lb] Max. torque

Recommended torque on nut to align the slotted nut with the shaft cross hole:

(373Nm [275 lb-ft] Dry)

(305Nm [225 lb-ft] Lub)

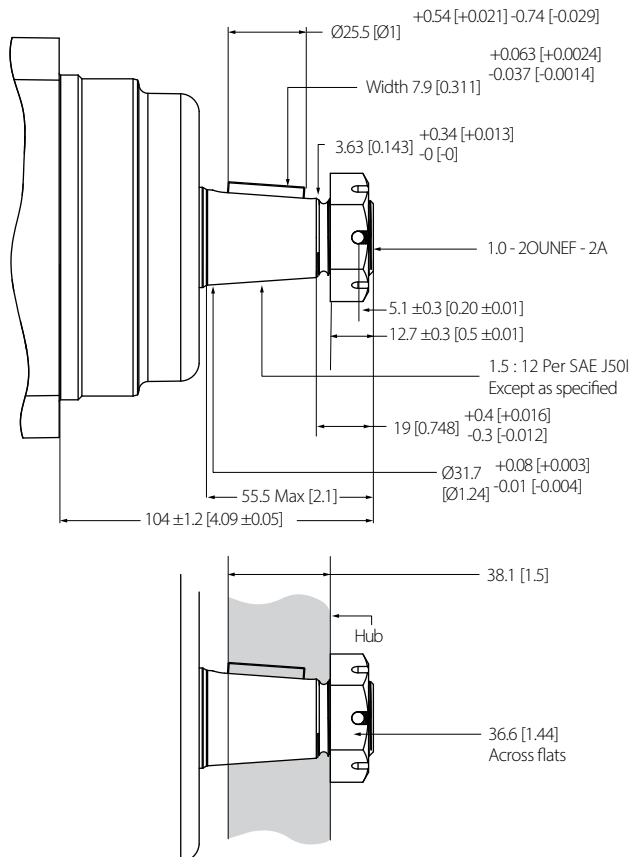

### 31.75 [1.25] 14 Tooth Splined (04)

768Nm [6800 in-lb] Max. torque

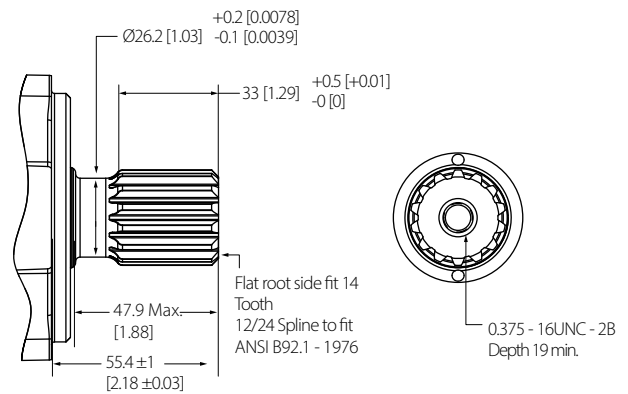



### 32mm Straight (16)

768Nm [6800 in-lb] M ax . torque

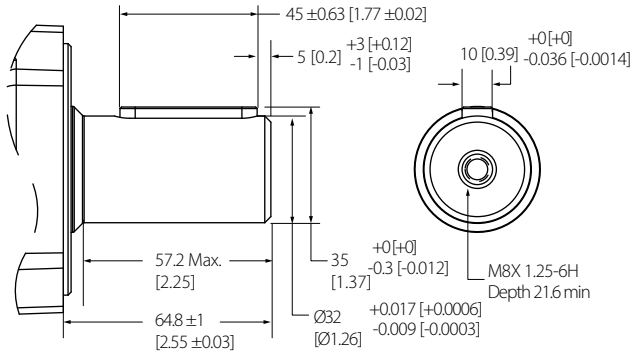

### SAE 6B Splined (35)

395Nm [3500 in-lb] M ax . torque

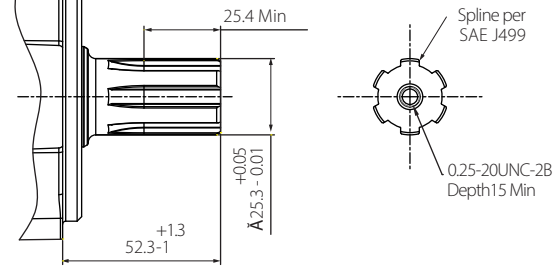

### 25mm Straight (98)

395Nm [3500 in-lb] M ax . torque

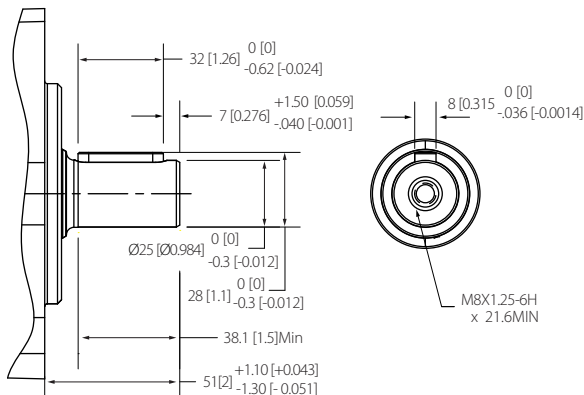

### 31.75 [1.25] 14 Tooth Spline extra length (99)

768Nm [6800 in-lb] M ax . torque

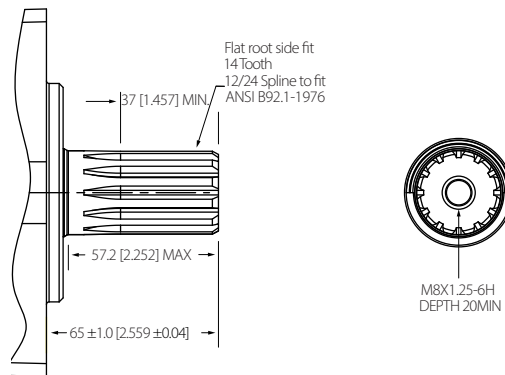

# XL2 Series

## Dimensions Ports

### Staggered Ports

Main Ports (2): 7/8-14UNF-2B SAE O-ring Ports- **AA**

Case Drain Port (1): 7/16-20UNF-2B SAE

O-ring Port -

or

Main Ports (2): G1/2 O-ring Ports- **AG**

Case Drain Port (1): G1/4 O-ring Port - **02**

**01**

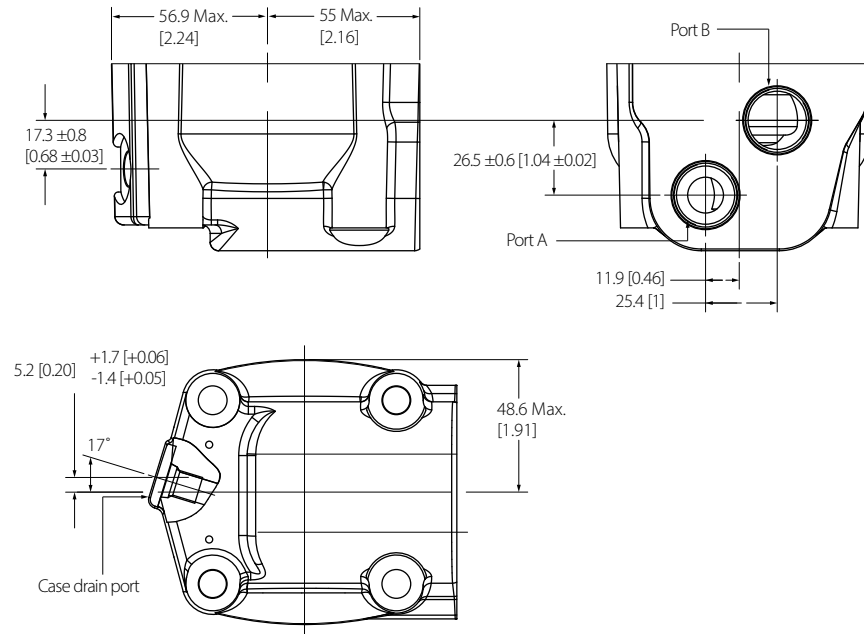

### Manifold Ports (AE)

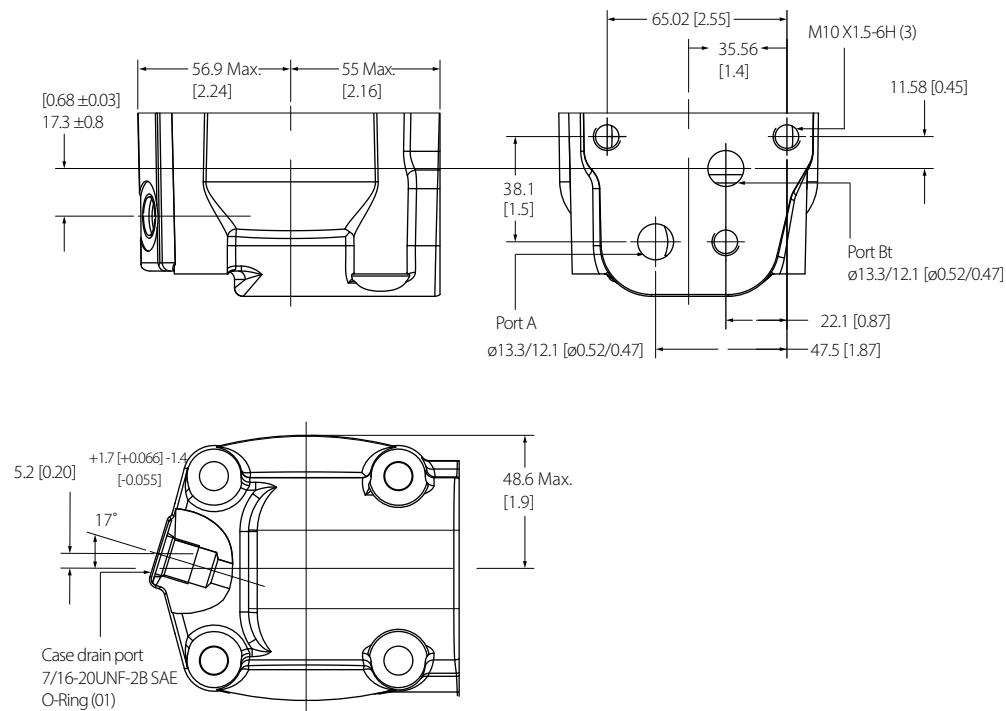

### Manifold Ports

G1/2 Staggered port(2) - **AS**

G1/4 Case drain port(1) - **02**

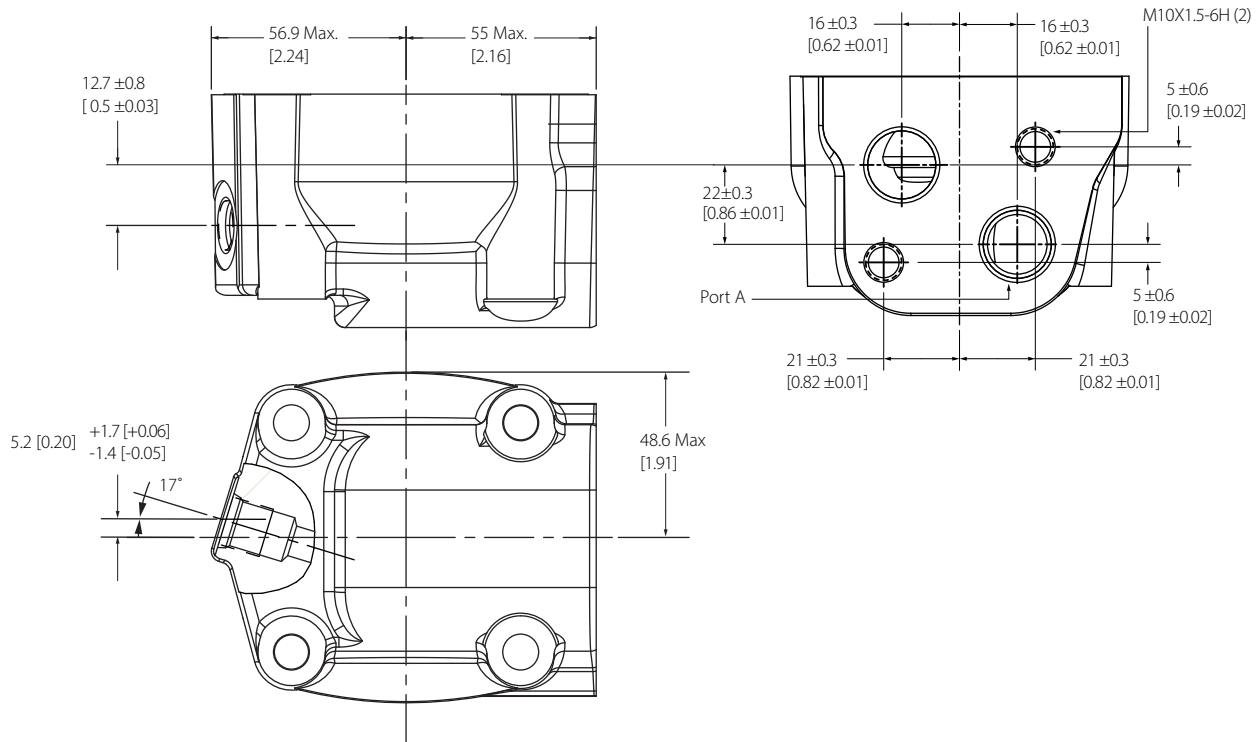

# XL2 Series

## Dimensions Ports

### End Ports

Main Ports (2): M 22X1 .5-6H End Ports- **ZA** Case

Drain Port (1): M14X1 .5-6H O-ring Port - **90**

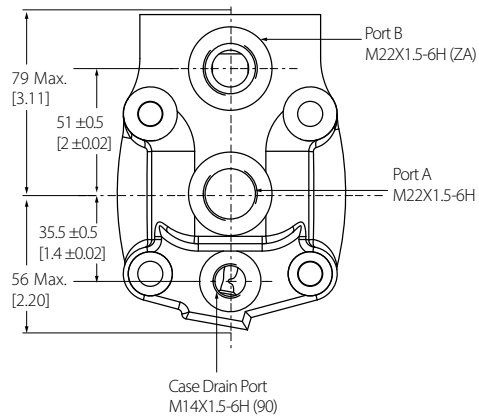

### Side Ports

Main Ports (2): M 22X1 .5-6H Ports (Positioned 180o Apart) -

**ZB** M14X1 .5-6H O-ring Port - **91**

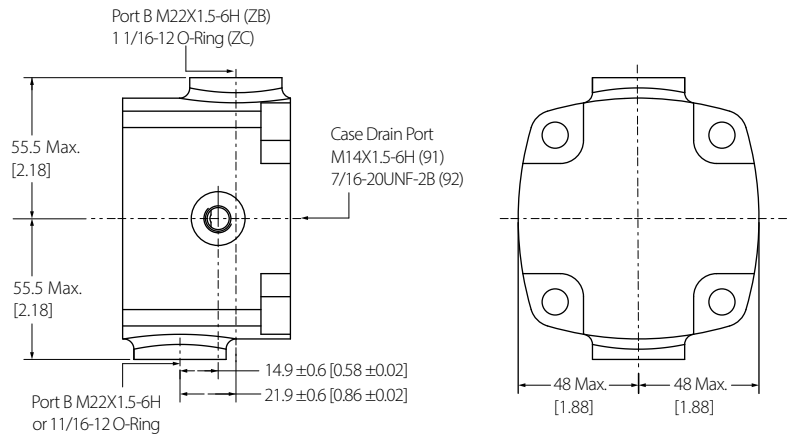

### Ports with Relief Valves

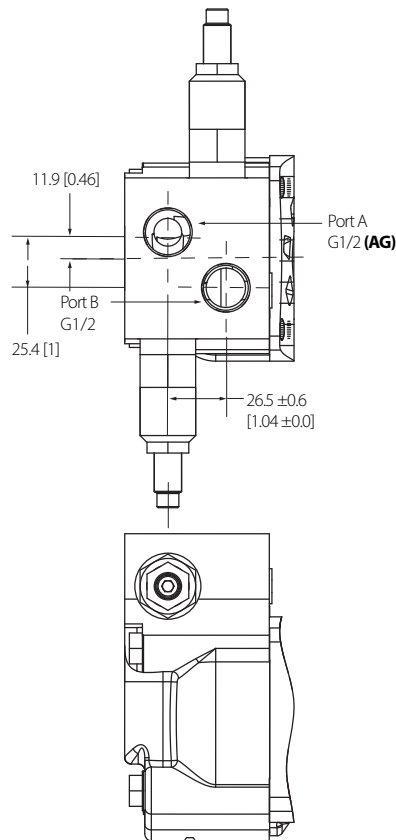
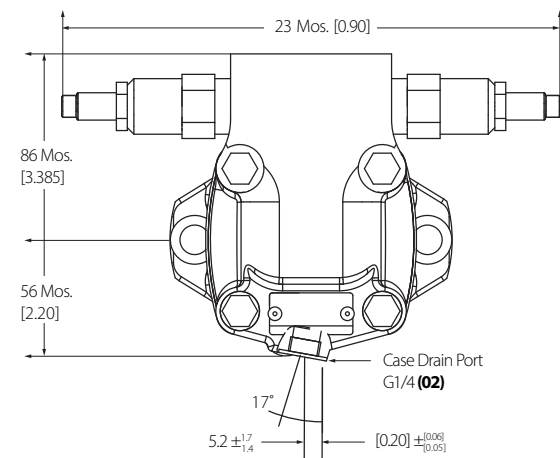

### Ports with Counterbalance Valve

7/8-14UNF-2B SAE O-ring Staggered Ports(2) - **AA**

7/16-20UNF-2B SAE O-ring Case Drain Port(1) - **01**

G1/2 Staggered Ports(2) - **AG**

G1/4 Case Drain Port(1) - **02**

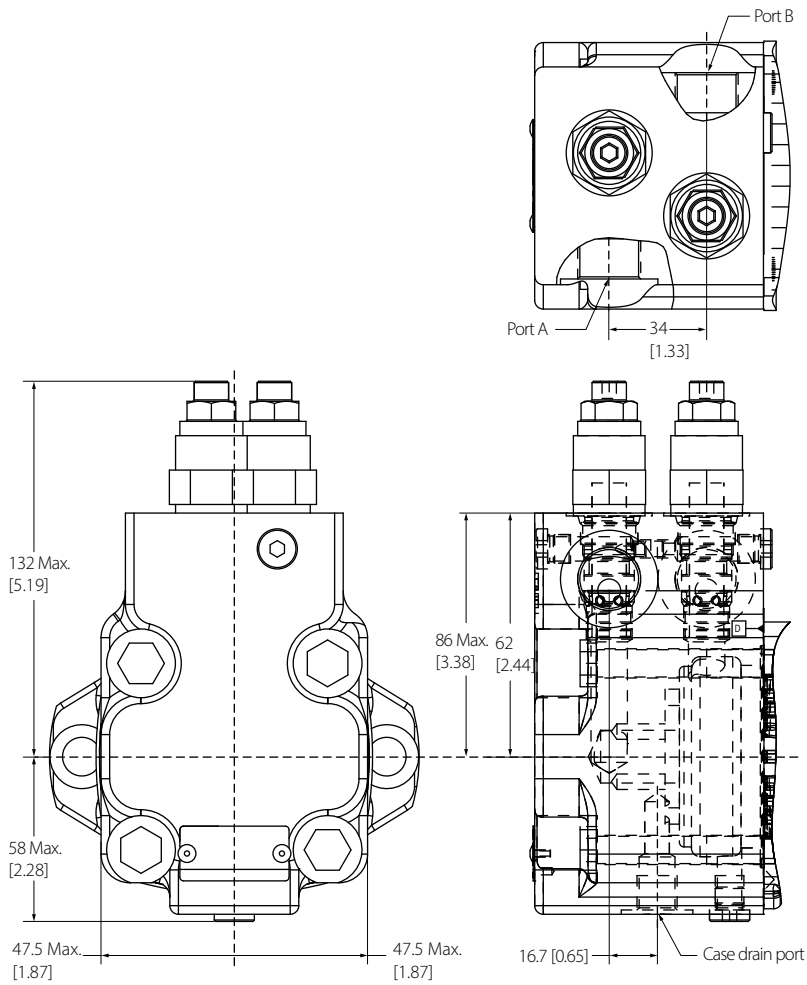

# XL2 Series

## Shaft Side Load Capacity

These curves indicate the radial load capacity on the motor shaft(s) at various locations with an allowable external thrust load of 454 kg . [1000 lb] .

**Note:** Case pressure will increase the allowable inward thrust load and decrease the allowable outward thrust load . Case pressure will push outward on the shaft at 94 kg/7 Bar [208 lb/100 psi].

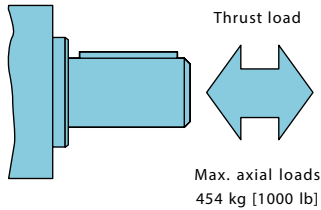

**Each curve is based on a B10 bearing life of 2000 hours. The 12,000,000 revolution curve represents 100 RPM. The 3,000,000 revolution curve represents 25 RPM.**

To determine radial load at speeds other than 25 R PM and 100 R PM , multiply the load values on the 12M revolution curve by the factors in the chart below .

RPM	Multiplication factor
50	1.23
100	1.00
200	0.81
300	0.72
400	0.66
500	0.62
600	0.58
700	0.56
800	0.54

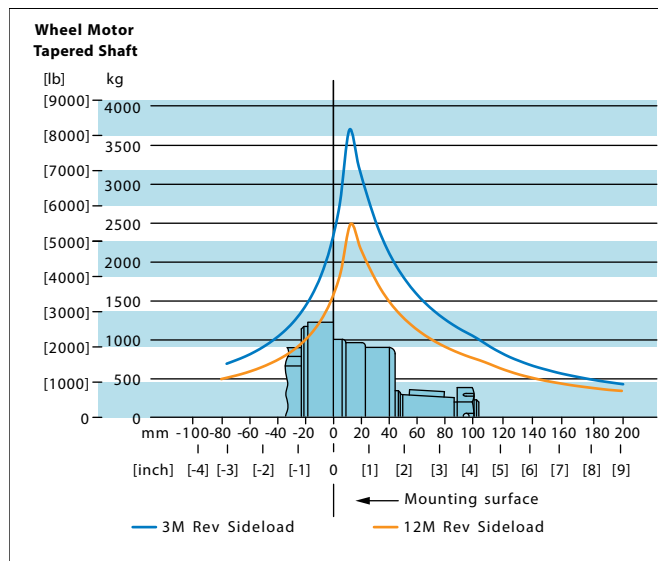
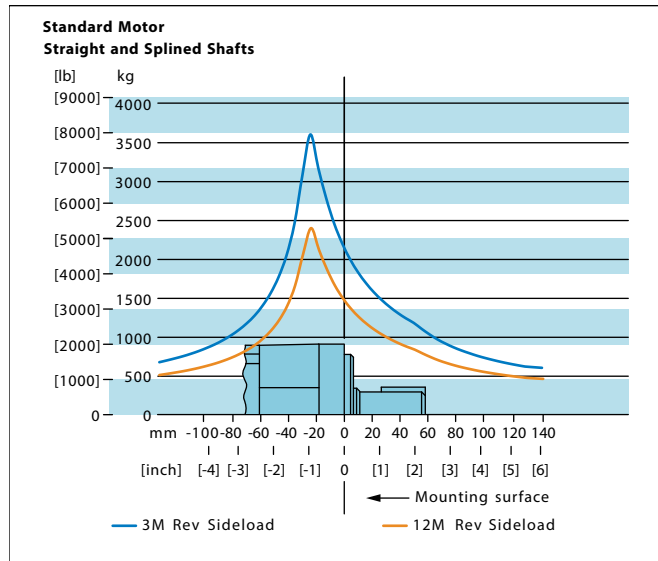

Xcel XL2 Series Case Pressure Seal Limitation motors are durable and have long life as long as the recommended case pressure is not exceeded. Allowable case pressure is highest at low shaft speeds. Consequently, motor life will be shortened if case pressure exceeds these ratings (acceptability may vary with application). Determine if an external case drain is required from the case pressure seal limitation chart.

**Case porting advantage**

**Contamination Control** - flushing the motor case .

**Cooler motor** - exiting oil draws motor heat away.

**Extend motor seal life** - maintain low case pressure with a preset restriction in the case drain line .

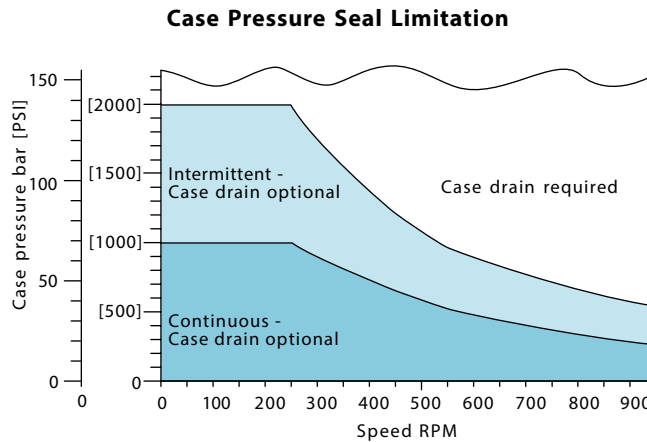

# XL2 Series

## Model Code

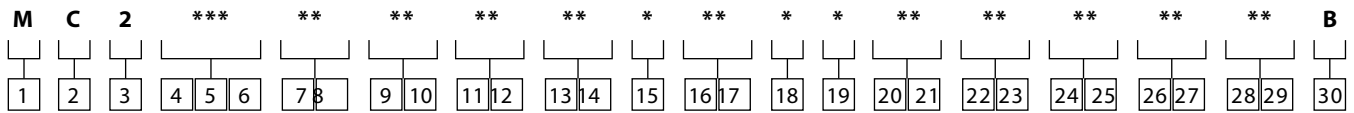

**1** **Product**  
**M** Motor

**2** **3** **Series**  
**C 2** Xcel XL2 Series

<b>4</b>	<b>5</b>	<b>6</b>	<b>Displacement</b>	<b>cm<sup>3</sup>/r</b>	<b>[in<sup>3</sup>/r]</b>
<b>080</b>			80 .6	[4 .92]	
<b>100</b>			101 .6	[6 .20]	
<b>130</b>			130 .6	[7 .97]	
<b>160</b>			158 .1	[9 .65]	
<b>195</b>			194 .8	[11 .89]	
<b>245</b>			244 .3	[14 .91]	
<b>305</b>			306 .6	[18 .71]	
<b>395</b>			393 .8	[24 .03]	
<b>490</b>			489 .0	[29 .8]	

**7** **8** **Mounting description**

**AB** W heel, 4 bolt: 108 .0 [4 .25] Pilot dia . 13 .59 [.535] dia . Holes on 147.6 [5 .81] dia . B olt circle . 127.0 [5 .00] dia . Rear mount pilot

**AC** Standard, 2 bolt: 82 .6 [3 .25] Pilot dia . 13 .59 [.535] dia . Holes on 106 .4 [4 .19] dia . B olt circle . S AE A

**AD** Bearingless (w/ leakage slots), 4 bolt: 101 .6 [4 .00] Pilot dia . 13 .59 [.535] dia . Holes on 127 .0[5 .00] dia . bolt circle

**AH** Standard, 4 bolt: 82 .6 [3 .25] Pilot dia . 13 .59 [.535] dia . Holes on 106 .4 [4 .19] dia . B olt circle

**AJ** Standard (magneto), 4 bolt: 82 .6 [3 .25] Pilot dia . 13 .59 [.535] dia . Holes on 106 .4 [4 .19] dia . B olt circle . 2 .79 [.110] Pilot length

**9** **10** **Output shaft description**

**1** 25 .4 [1 .000] dia . straight shaft with .250-20 UNC-2B hole in shaft end, woodruff key

**2** 31 .75 [1 .250] dia . straight shaft with .375 -16 UNC-2b thread in end, 7 .938 [.3125] Sq . X 31 .75 [1 .250] straight key

**3** 31 .75 [1 .250] dia . .125:1 tapered shaft per SAE j501 with 1 .000-20 UNEF-2A threaded shaft end and slotted hex nut, 7 .938 [.3125] sq . X 25 .40 [1 .000] straight key

**4** 31 .75 [1 .250] Dia . flat root side fit, 14 tooth, 12/24 dp 30 deg . involute spline with .375-16UNC-2B thread in end, 33 .0 [1 .30] minimum full spline length

**16** 32 .00 [1 .260] dia . straight shaft with M 8 X 1 .25-6H thread in end, 9 .982 [.3930] W X 7 .995 [.3132]H x 45 .00 [1 .772]L key

**35** 25 .40 [1 .000] dia . 6B spline per SAE J 499 with .250-20 UNC-2B thread in end, 25 .40 [1 .000] minimum full spline length

**98** 25 .00 [.984] dia . straight shaft with M 8 X 1 .25-6H thread in end, 7.982 .3142]W X 6 .954 [.2738]H X 32[1 .260]L key

**99** 31 .75 [1 .250] dia . Flat root side fit, 14 tooth, 12/24 DP 30 deg . Involute spline with M 8X1 .25-6H thread in end, 37 .0 [1 .46] minimum full spline length, 139[5 .471] oal shaft length

**11** **12** **Port description**

**AA** 7/8-14UNF-2B SAE O-ring ports - staggered ports

**AE** 13 .0 [.512] dia . manifold ports with 3X M10 X 1 .5-6H port block mounting holes

**AG** G 1/2 B SP straight THD ports- staggered ports

**AS** G 1/2 B SP straight THD ports – staggered port with 2X M10 X 1 .5-6H port block mounting holes - European

**BA** M22X 1 .5-6H ports per ISO9974-1- staggered ports

**ZA** M22X 1 .5-6H ports per ISO9974-1- end ports

**ZB** M22X 1 .5-6H ports per ISO9974-1- side ports (Position 180oapart)

**ZC** 1 1/16-12 O-ring ports -side ports (Position 180oapart)

**13** **14** **Case flow options**

**0** None

**1** 7/16-20UNF-2B SAE O-ring port

**2** G 1/4 B SP straight THD port

**10** G 1/4 B S P straight THD port with optional G 1/4 B SP straight THD port in mounting flange

**90** M14X 1 .5-6H ports per ISO9974-1- end ports

**91** M14X 1 .5-6H ports per ISO9974-1- side ports (Position 180oapart)

**92** 7/16-20 O-ring ports -side ports (Position 180oapart)



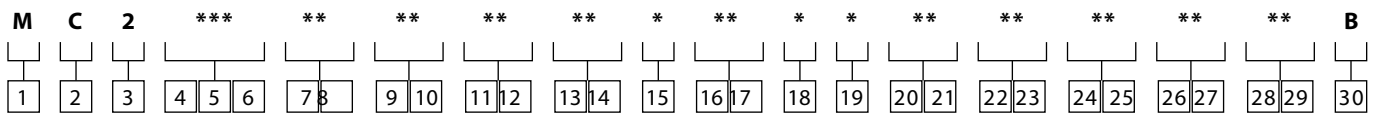

**15**      **Low pressure relief**  
**0**      None

**16** **17**      **Pressure/flow option**  
**00**      None  
**17**      Relief valve set @ 170 .0 bar [2465 lbf/in<sup>2</sup>]

**18**      **Geroler option**  
**1**      Standard

**19**      **Seal option**  
**0**      Standard  
**3**      High pressure shaft seal  
**4**      Seal guard  
**6**      High pressure shaft seal, seal guard

**20** **21**      **Accessories**  
**00**      None  
**AE**      M12 threaded connector, long body digital speed and direction pickup (two 30 pulse signals in quadrature per revolution pin 1=power supply, pin 2=output signal 1, pin 3=common, pin 4=output signal 2) Supply voltage: 8 to 28 V DC Output voltage low: 0 .5 V DC M ax at 10 mA

**22** **23**      **Special features (hardware)**  
**00**      None (Standard)

**24** **25**      **Special features (assembly)**  
**00**      None (Standard)  
**AA**      Flange rotated 90° degrees  
**AB**      Reverse rotation  
**AC**      Flange rotated 90° degrees, reverse rotation

**26** **27**      **Paint/packaging**  
**AA**      Blue  
**AB**      Black

**28** **29**      **Customer identification or name plate**  
**AA**      Standard

**30**      **Design code**  
**B**      Second

\* For more special features contact your Danfoss representative .

# XL4 Series

## Highlights



## Description

Danfoss' Xcel™ Series Low Speed High Torque Disc Valve motors offer the most popular features and options from the parallel Danfoss Char-Lynn range and are optimized to bring the highest value in medium duty applications.

### Features

- 6 displacements, a variety of mounting flanges and output shafts
- Reliable, proven design
- High efficiency

### Benefits

- Flexibility in designing this motor into a system
- Options that fit well into tough applications

### Applications

- Mowers
- Snow Removal
- Sprayers
- Trenching machines
- Wood Processing Machines

### XL4 Series Motors

Geroler® Element	6 Displacements
Flow l/min [GPM]	95 [25] Continuous** 150 [40] Intermittent*
Speed RPM	582 Cont.** 693 Inter.*
Pressure bar [psi]	205 [3000] Cont.** 310 [4500] Inter.*
Torque Nm [lb-in]	945 [8400] Cont.** 1170 [10350] Inter.*

\*\* Continuous— (Cont.) Continuous rating, motor may be run continuously at these ratings

\* Intermittent— (Inter.) Intermittent operation, 10% of every minute.

# XL4 Series

## Specifications

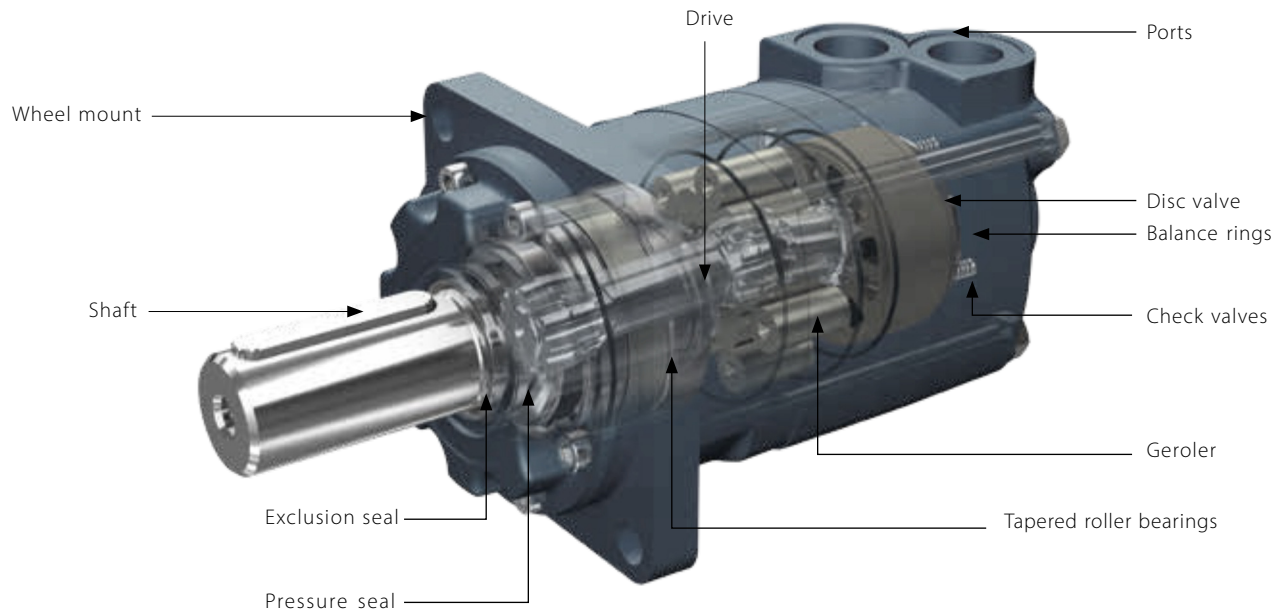

### Specification Data

Displacement cm <sup>3</sup> /r [in <sup>3</sup> /r]		160 [9.8]	205 [12.5]	245 [15.0]	310 [19.0]	395 [24.0]	495 [30]
Flow LPM [GPM]	Continuous	95 [25]	95 [25]	95 [25]	95 [25]	95 [25]	95 [25]
	Intermittent	115 [30]	115 [30]	130 [35]	130 [35]	150 [40]	150 [40]
Max. Speed RPM	Continuous	582	459	383	303	239	191
	Intermittent	693	546	532	422	376	305
Pressure ΔBar [Δpsi]	Continuous	205 [2973]	205 [2973]	205 [2973]	205 [2973]	190 [2750]	140 [2000]
	Intermittent	310 [4500]	310 [4500]	310 [4500]	260 [3750]	240 [3500]	170 [2500]
Torque* Nm [lb-in]	Continuous	485 [4292]	600 [5310]	705 [6239]	850 [7523]	930 [8240]	945 [8375]
	Intermittent	705 [6239]	800 [7080]	845 [7478]	1065 [9425]	1185 [10470]	1170 [10350]
Weight Kg [lbs]	Standard or wheel mount	18.1 [39.9]	18.4 [40.6]	18.6 [41]	19.5 [43]	20.4 [45]	21.8 [48.1]
	Bearingless	14.1 [31.1]	14.5 [32]	14.7 [32.4]	15.6 [34.4]	16.6 [36.6]	17.9 [39.5]

Maximum Case Pressure: See case pressure seal limitation graph

\*See shaft torque ratings for limitations .

**Note:** To assure best motor life, run motor for approximately one hour at 30% of rated pressure before application to full load . Be sure motor is filled with fluid prior to any load applications .

#### Max. inlet pressure:

310 bar [4500 psi]

Do not exceed Δ pressure rating (see chart above).

#### Max. return pressure:

310 bar [4500 psi] with case drain line installed .

Do not exceed Δ pressure rating (see chart above).

#### ΔBar [Δpsi]:

The true pressure difference between inlet port and outlet port .

#### Continuous rating:

Motor may be run continuously at these ratings .

#### Intermittent operation:

10% of every minute .

#### Recommended fluids:

Premium quality, anti-wear type hydraulic oil with a viscosity of not less than 13 cSt (70 SUS) at operating temperature .

#### Recommended system operating temp.:

-34°C to 82°C [-30°F to 180°F]

#### Recommended filtration

per ISO Cleanliness Code, 4406: 20/18/13

# XL4 Series

## Performance Data

Function Diagram: XL4 motor 160 cc

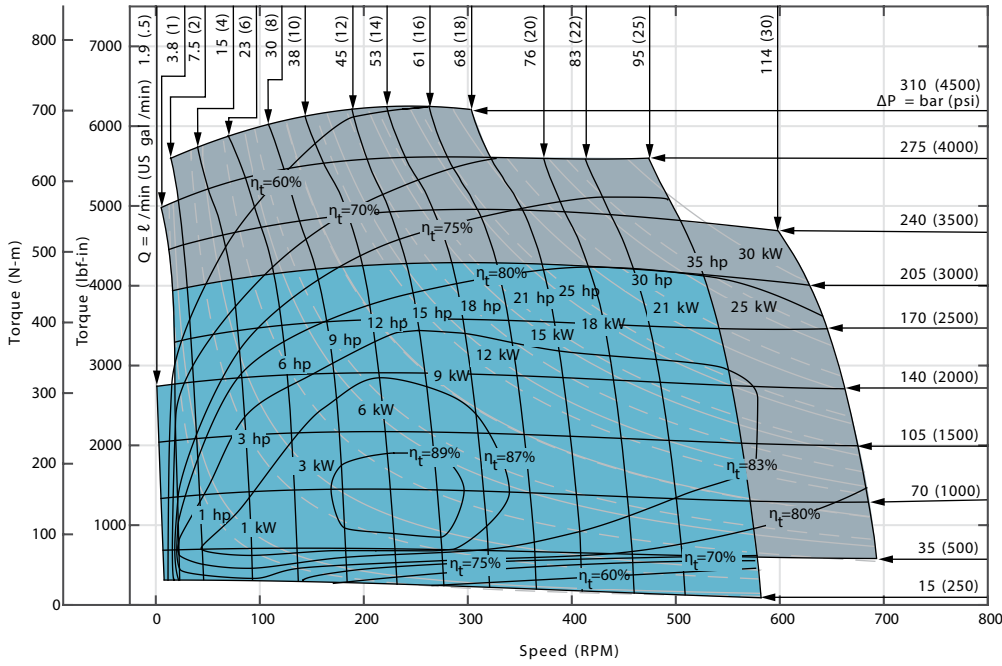

Performance data is typical at 25 cSt (120 SUS). Actual data may vary slightly from unit to unit in production.

$\eta_t$  = overall efficiency

- Continuous
- Intermittent

Function Diagram: XL4 motor 205 cc

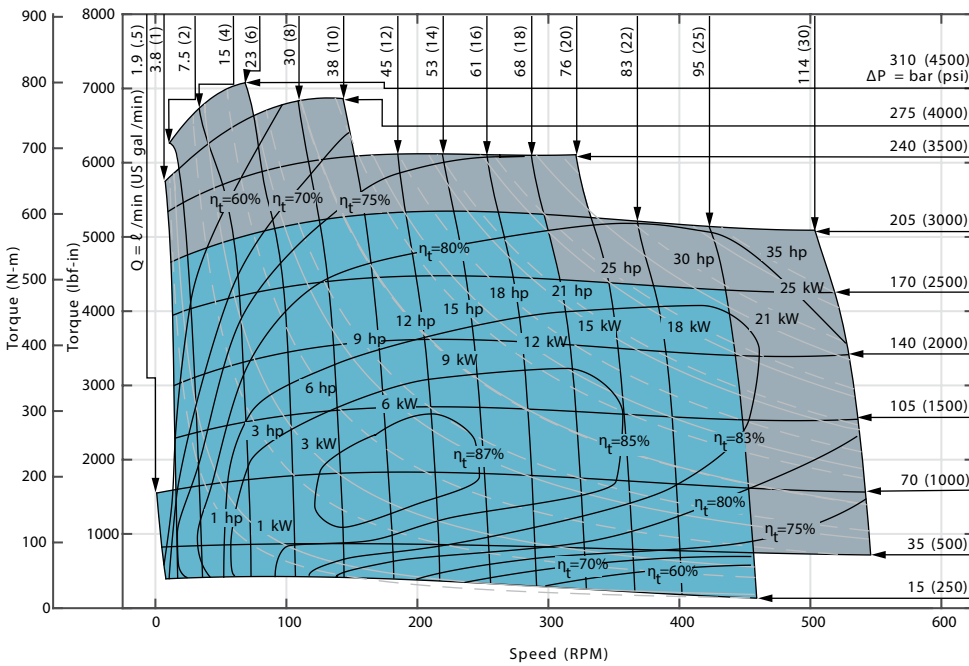

# XL4 Series

## Performance Data

Function Diagram: XL4 motor 245 cc

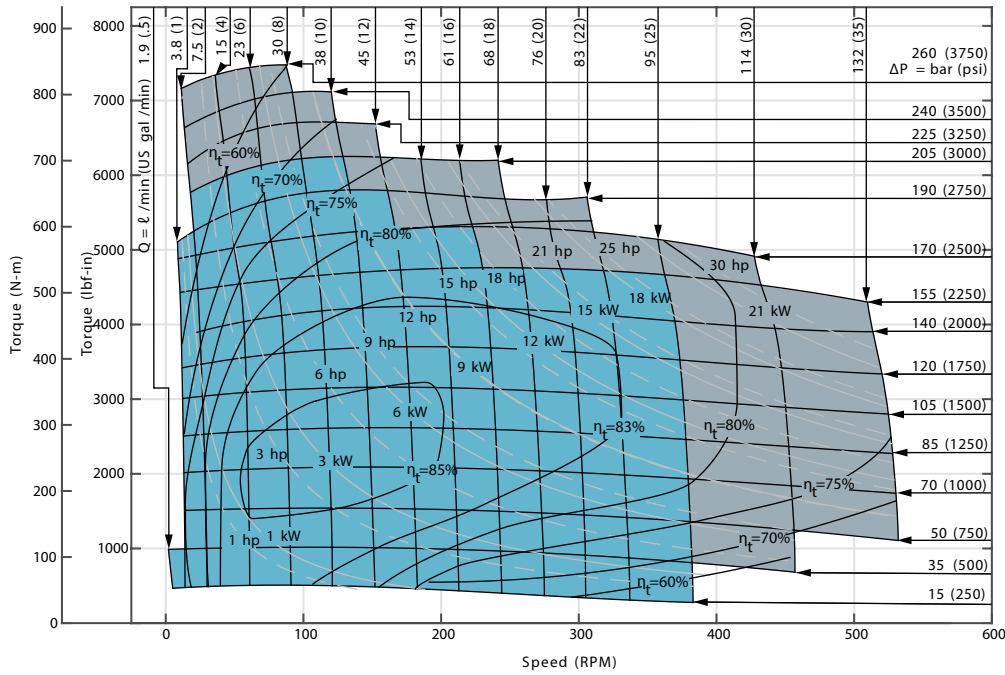

Performance data is typical at 25 cSt (120 SUS). Actual data may vary slightly from unit to unit in production.

$\eta_t$  = overall efficiency

Continuous

Intermittent

Function Diagram: XL4 motor 310 cc

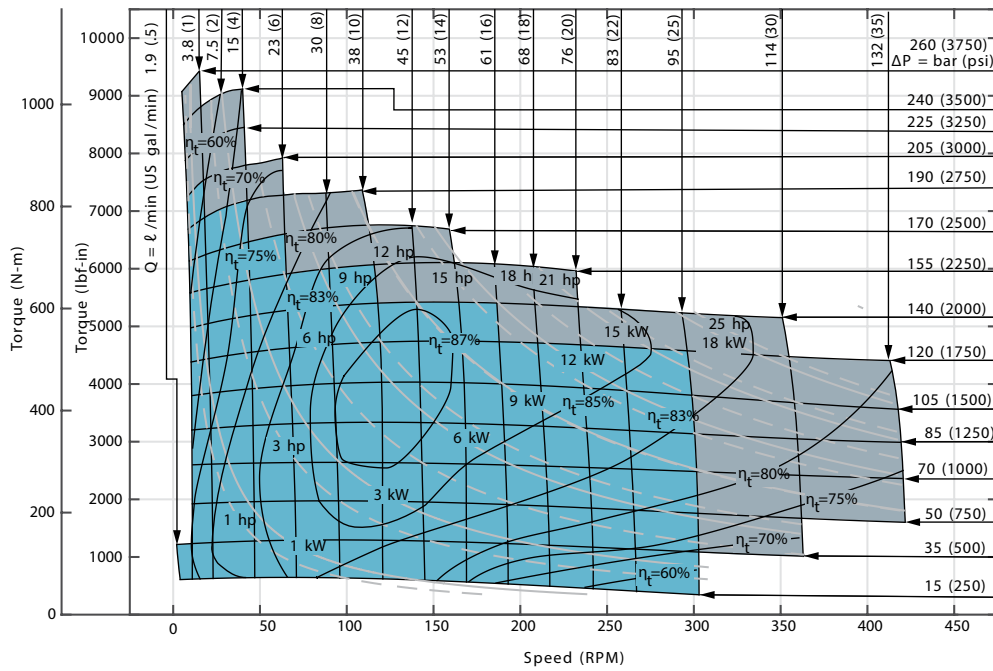

# XL4 Series

## Performance Data

Function Diagram: XL4 motor 395 cc

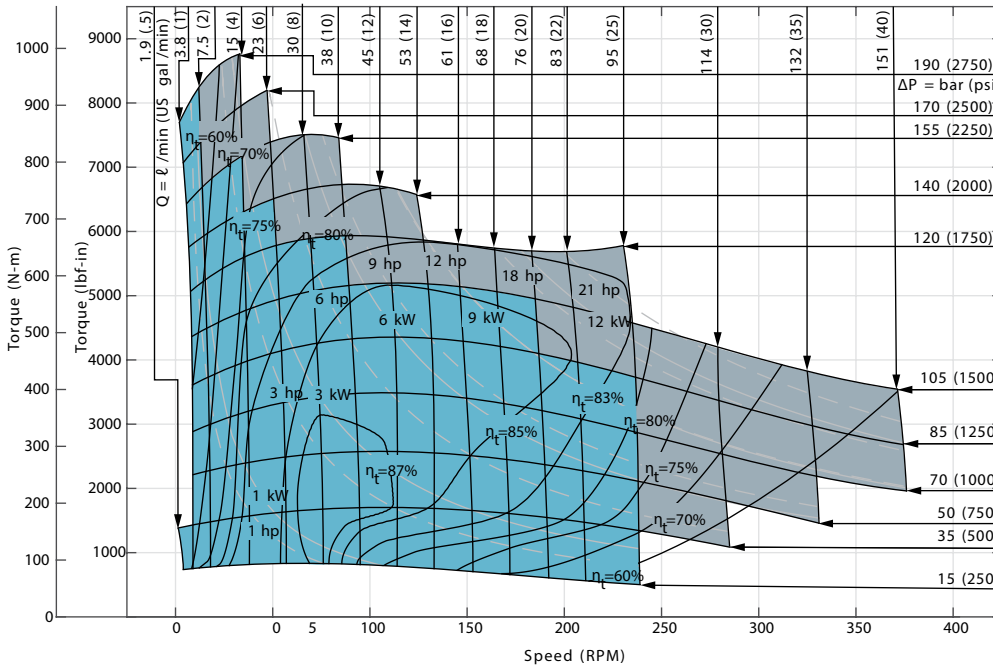

Performance data is typical at 25 cSt (120 SUS). Actual data may vary slightly from unit to unit in production.

$\eta_t$  = overall efficiency

- Continuous
- Intermittent

Function Diagram: XL4 motor 495 cc

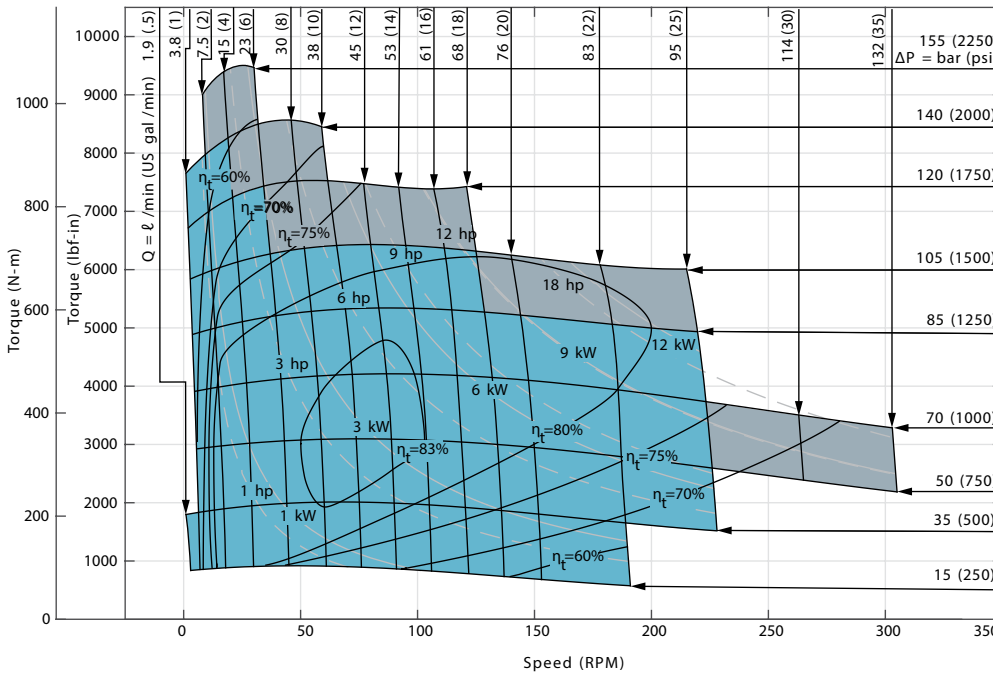

### Standard Rotation Viewed from Shaft End

Port A Pressurized — CW

Port B Pressurized — CCW

XL4 Standard Shaft Seal and Section Seal Kit Number: **Z331-32**

### Standard Mount (AB)

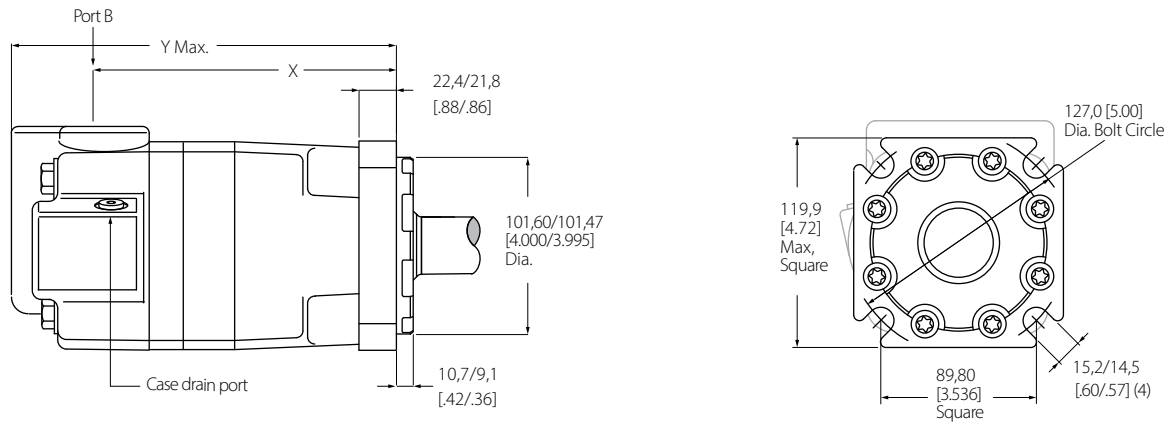

### SAE C Flange (AC)

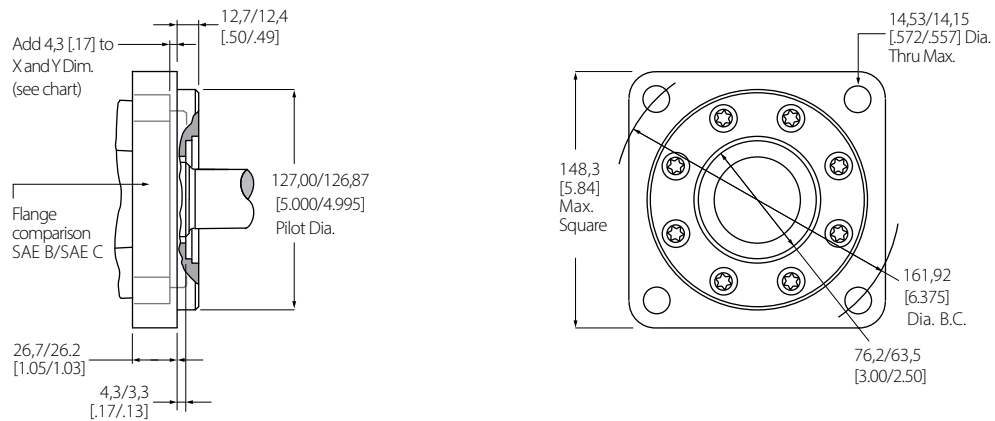

#### Standard mount motor dimensions

Displacement	X		Y	
	mm	[inch]	mm	[inch]
160 [9.9]	168,7	[6.64]	224,7	[8.85]
205 [12.5]	177,2	[6.98]	233,2	[9.18]
245 [15.0]	168,7	[6.64]	224,7	[8.85]
310 [19.0]	177,2	[6.98]	233,2	[9.18]
395 [24.0]	187,9	[7.40]	243,9	[9.60]
495 [30.0]	200,7	[7.90]	256,8	[10.11]

# XL4 Series

## Dimensions - Standard/Wheel Mount

### Standard Rotation Viewed from Shaft End

Port A Pressurized — CW

Port B Pressurized — CCW

### ISO 125 B4HW Flange (AD)

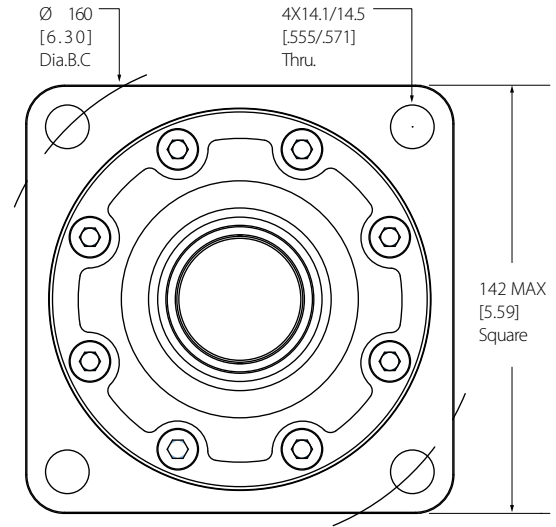
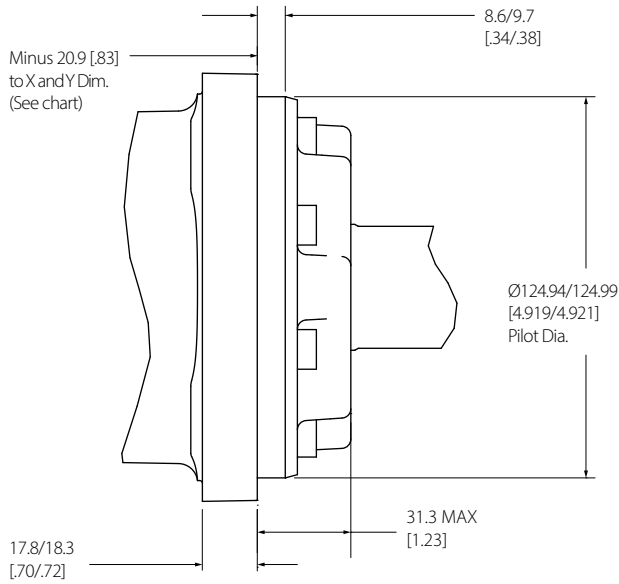

Standard mount motor		dimensions			
Displacement		X		Y	
cm <sup>3</sup> / r [in <sup>3</sup> / r]		mm	[inch]	mm	[inch]
160	[9.9]	168,7	[6.64]	224,7	[8.85]
205	[12.5]	177,2	[6.98]	233,2	[9.18]
245	[15.0]	168,7	[6.64]	224,7	[8.85]
310	[19.0]	177,2	[6.98]	233,2	[9.18]
395	[24.0]	187,9	[7.40]	243,9	[9.60]
495	[30.0]	200,7	[7.90]	256,8	[10.11]



### Standard Rotation Viewed from Shaft End

Port A Pressurized — CW

Port B Pressurized — CCW

### Bearingless Mount (AA)

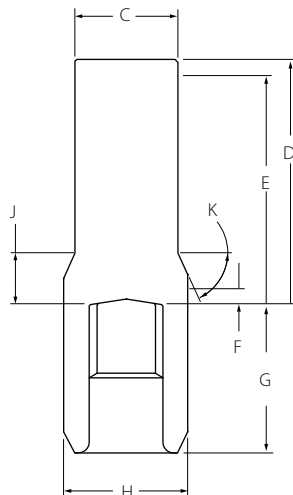
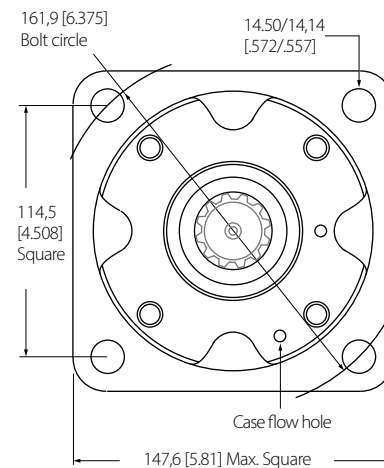
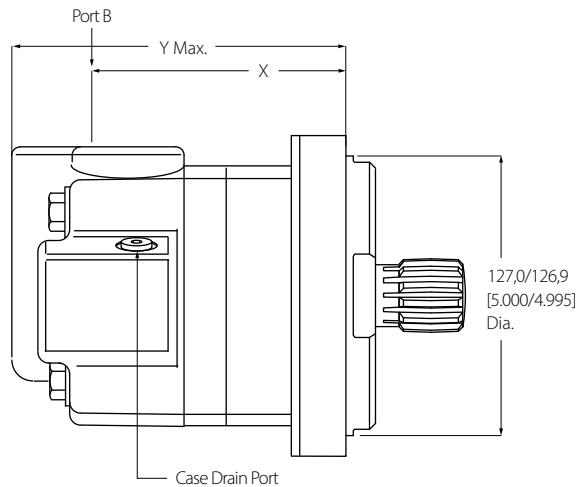

- C 47,2 [1,86] Dia.
- D 112,5 [4,43] Max.
- E 107,4 [4,23] Full formDia.
- F 7,4 [29] Min. Full formDia.
- G 68,8 [2,71] Max.
- H 56,9 [2,24] Dia.
- J 18,29 [7,20]
- K 38°

Mating Coupling Blank  
Danfoss Part No.  
12745-003

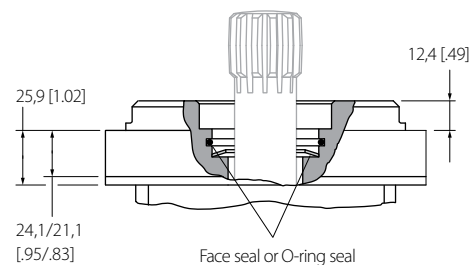
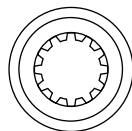

Bearingless motor		dimensions			
		X		Y	
Displacement		mm	[inch]	mm	[inch]
160	[9.9]	101,4	[4.00]	157,1	[6.19]
205	[12.5]	109,9	[4.33]	165,7	[6.52]
245	[15.0]	101,4	[4.00]	157,1	[4.19]
310	[19.0]	109,9	[4.33]	165,7	[6.52]
395	[24.0]	120,6	[4.75]	176,3	[6.94]
495	[30.0]	133,5	[5.26]	189,2	[7.45]

For Xcel XL4 Series bearingless motor application information contact your Danfoss representative (mating coupling blanks available from Danfoss).

**Note:** After machining blank, part must be hardened per Danfoss specification .

# XL4 Series

## Installation Information Bearingless

- ① Internal spline in mating part to be as follows: Material to be ASTM A304, 8620H . Carbonize to a hardness of 60-64 HRc with case depth (to 50HRc) of 0,076 - 1,27 [.030 - .050] (dimensions apply after heat treat).
- ② Mating part to have critical dimensions as shown . Oil holes must be provided and open for proper oil circulation .
- ③ Seal to be furnished with motor for proper oil circulation thru splines .
- ④ Some means of maintaining clearance between shaft and mounting flange must be provided .
- ⑤ Counterbore designed to adapt to a standard sleeve bearing 50,010 - 50,040 [1.9689 - 1.9700] ID by 60,050 - 60,080 [2.3642 - 2.3653] (Oilite bronze sleeve bearing).
- ⑥ Similar to SAE "C" Four Bolt Flange .
- ⑦ 52,8 [2.08] Max . dimension to be maintained when assembling shipping and installing unit to insure valve drive engagement with valve

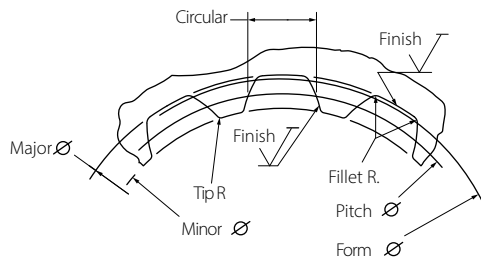
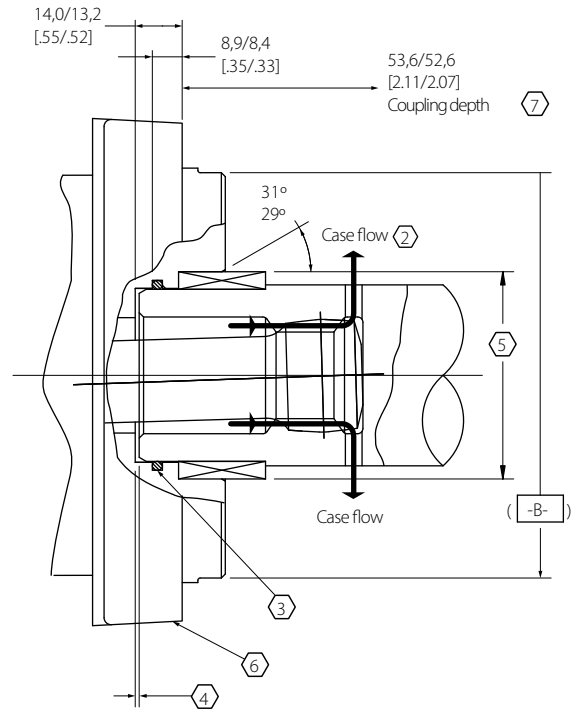
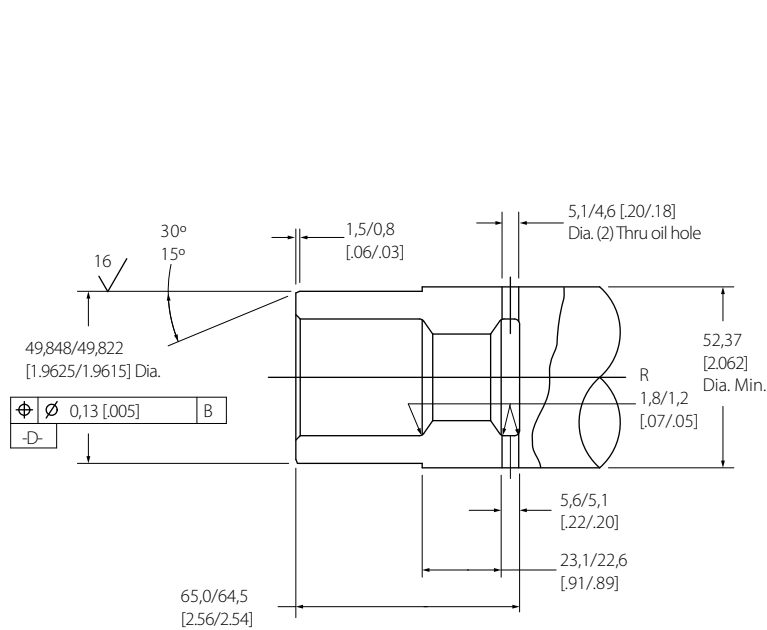

Spline Pitch	10/20
Pressure Angle	30°
Number of teeth	12
Class of Fit	Ref. 5
Type of Fit	Side
Pitch Diameter	Ref. 30,480000 [1.2000000]   0,20 [0,008]   D
Base Diameter	Ref. 26,396455 [1.0392305]
Major Diameter	33,43 [1.316] Max. 33,23 [1.308] Min.
Min. Minor Diameter	28,40 - 28,58 [1.118 - 1.125]
Form Diameter, Min	32,59 [1.283]
Fillet Radius	0,63 - 0,76 [0,025 - 0,030]
Tip Radius	0,26 - 0,51 [0,010 - 0,020]
Finish	1,6 (63)
Involute Profile Variation	+0,000 -0,025 [+0,0000 -0,0010]
Total Index Variation	0,038 [0,0015]
Lead Variation	0,013 [0,0005]
<b>Circular Space Width:</b>	
Maximum Actual	5,045 [1,986]
Minimum Effective	4,995 [1,951]
Maximum Effective	Ref. 5,009 [1,972]
Minimum Actual	Ref. 4,986 [1,963]
Dimension Between Two Pins	Ref. 22,783 - 22,929 [8,970 - 9,027]
Pin Diameter	5,334 [2,100] Pins to Have 3,73 [1,47]
	Wide Flat for Root Clearance

### 31.75 [1.25] 14 Tooth Splined (02)

768 Nm [6800 in-lb] M ax . torque

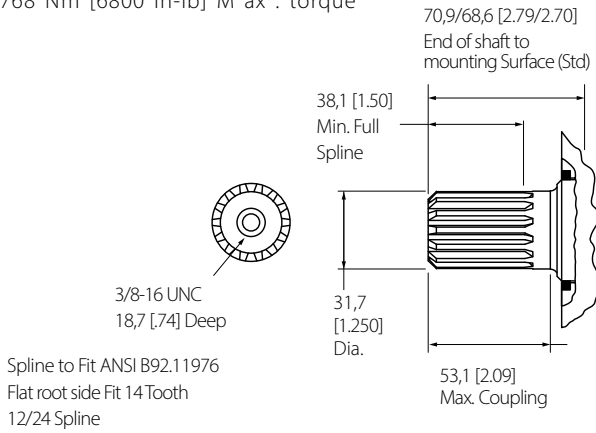

### 38.1 [1.50] 17 Tooth Splined (05)

972 Nm [8600 in-lb] M ax . torque

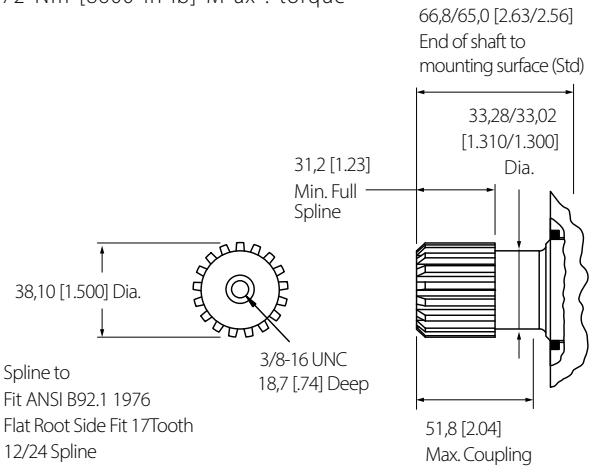

### 40mm Straight (04)

972 Nm [8600 in-lb] M ax . torque

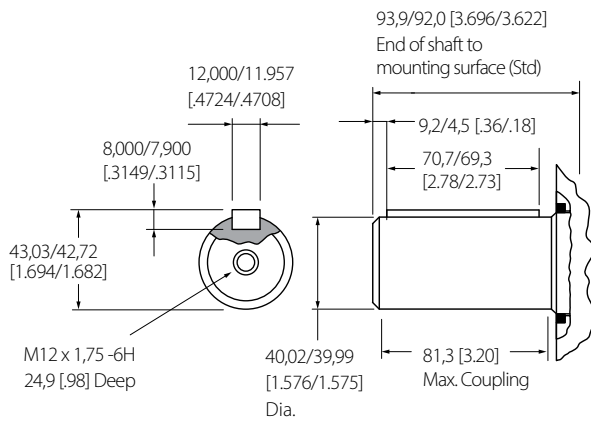

### 38.1 [1.50] 17 Tooth Splined (03)

972 Nm [8600 in-lb] M ax . torque

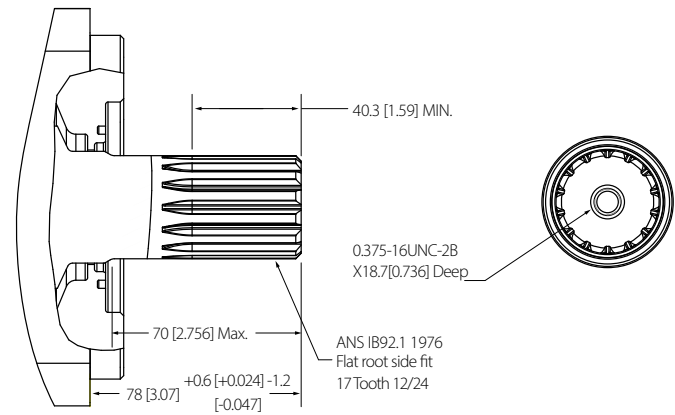

# XL4 Series

## Dimensions Ports

### Ports (Preferred)

1 1/16 -12 UN-2B SAE O-ring Staggered Ports (2) - **AC**

7/16 -20 UNF-2B SAE O-ring Case Drain Port (1) - **03 or**

G3/4 (B SP) Staggered Ports (2) - **AB**

G1/4 (B SP) Case Drain Port (1) - **02**

**or**

M 27X2 Staggered Ports(2) - **AA**

M14X1 .5 Case Drain Port(1) - **01**

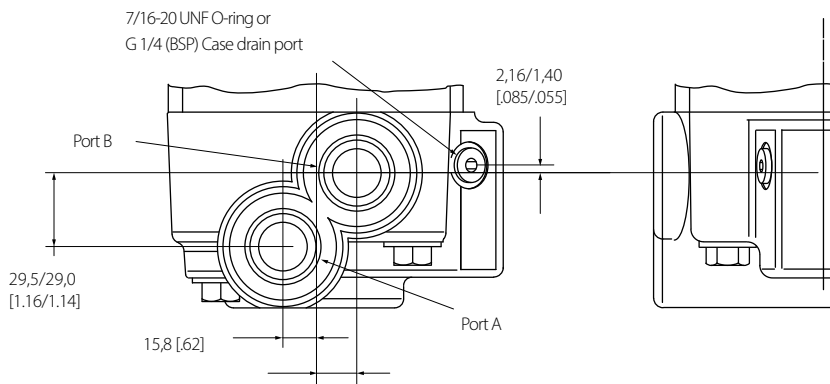

These curves indicate the radial load capacity on the motor shaft(s) at various locations with an allowable external thrust load of 454 kg [1000 lb] .

**Note:** Case pressure will increase the allowable Inward thrust load and decrease the allowable outward thrust load . Case pressure will push outward on the shaft at 94 kg/7 Bar [208 lb/100 psi].

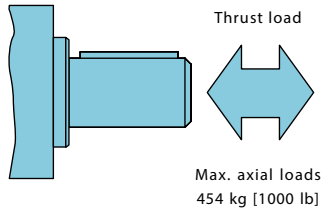

**Each curve is based on a B10 bearing life of 2000 hours. The 12,000,000 revolution curve represents 100 RPM. The 3,000,000 revolution curve represents 25 RPM.**

To determine radial load at speeds other than 25 RPM and 100 RPM , multiply the load values on the 12M revolution curve by the factors in the chart below .

RPM	Multiplication factor
50	1.23
100	1.00
200	0.81
300	0.72
400	0.66
500	0.62
600	0.58
700	0.56
800	0.54

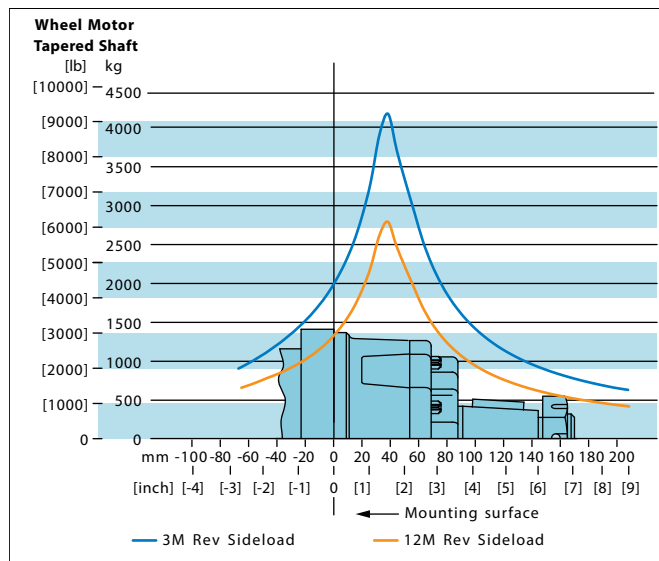
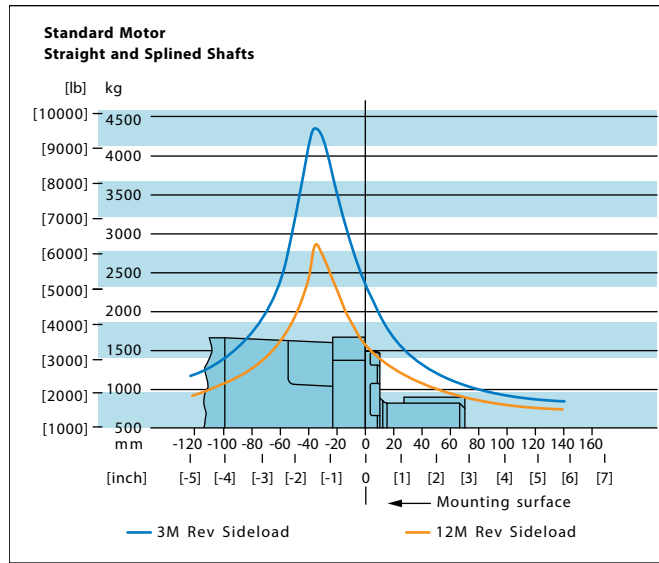

# XL4 Series

## Case Pressure and Case Porting

Xcel XL4 Series motors are durable and have long life as long as the recommended case pressure is not exceeded. Allowable case pressure is highest at lowshaft speeds . Consequently, motor life will be shortened if case pressure exceeds these ratings (acceptability may vary with application). Determine if an external case drain is required from the case pressure seal limitation chart .

### Case porting advantage

**Contamination Control** - flushing the motor case .

**Cooler motor** - exiting oil draws motor heat away.

**Extend motor seal life** - maintain low case pressure with a preset restriction in the case drain line .

**Case Pressure Seal Limitation**

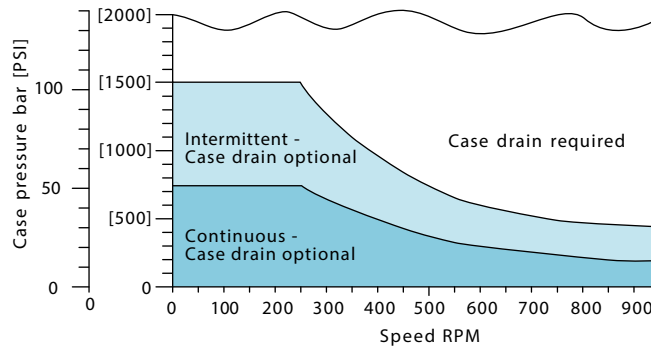

# XL4 Series

Model Code

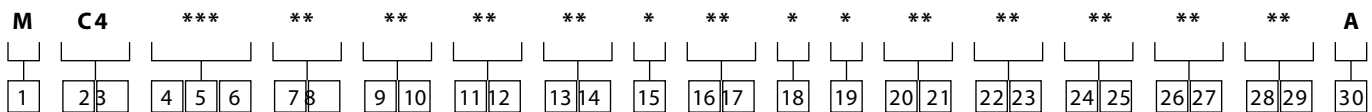

**1 Product**  
**M** Motor

**2 3 Series**  
**C4** Xcel XL4 Series

<b>4 5 6 Displacement</b>	<b>cm<sup>3</sup>/rev</b>	<b>[in<sup>3</sup>/r]</b>
<b>160</b>	162 .2 [9 .90]	
<b>205</b>	205 .5 [12 .54]	
<b>245</b>	246 .3 [15 .03]	
<b>310</b>	311 .8 [19 .03]	
<b>395</b>	393 .9 [24 .04]	
<b>495</b>	492 .6 [30 .06]	

**7 8 Mounting description**

<b>AA</b>	Bearingless, 4 bolt: 127.00 [5 .000] pilot DIA . 14 .27 [ .562] DIA . Holes on 161 .92 [6 .375] DIA . Bolt circle
<b>AB</b>	Standard, 4 bolt: 101 .60 [4 .000] pilot DIA . 14 .7 [ .58] slots on 127 .00 [5 .000] DIA . Bolt circle . (S AE B)
<b>AC</b>	Standard, 4 bolt: 127.00 [5 .000] pilot DIA . 14 .27 [ .562] DIA . Holes on 161 .92[6 .375] DIA . Bolt circle . (S AEC)
<b>AD</b>	Standard: ISO flange 125 B 4HW (ISO 3019/2) 124 .97 [4 .920] pilot DIA . 14 .27 [ .562] DIA . Holes on 160 .00 [6 .299] DIA . Bolt circle .

**9 10 Output shaft description**

<b>00</b>	None (bearingless)
<b>2</b>	31 .75 [1 .250] DIA . Flat root side fit, 14 tooth, 12/24 DP 30 deg . Involute spline, 38 .1 [1 .50] Minimum full spline length, with .375-16UNC-2B thread in end
<b>3</b>	38 .10 [1 .500] DIA . Flat root side fit, 17 TOOTH, 12/24 DP 30 deg . Involute spline, 40 .3 [1 .59] minimum full spline length, with .375-16 UNC-2B thread in end
<b>4</b>	40 .00 [1 .575] DIA . Straight with M12 x 1 .75-6H thread, 7 .955 [ .3132] x 11 .979 [ .4716] wide x 69 .98 [2 .755]straight key
<b>05</b>	38 .10 [1 .500] DIA . Flat root side fit, 17 tooth, 12/24 DP 30 DEG . Involute spline, 31 .2 [1 .23] minimum full spline length, with .375-16 UNC-2B thread in end

**11 12 Port description**

**AA** M 27x2- staggered ports  
**AB** G 3/4 ports -staggered ports  
**AC** 1 1/16-12UN-2B SAE O-ring ports - staggered ports

**13 14 Case flow options**

<b>1</b>	M 14x1 .5 straight thread with check valve
<b>2</b>	G 1/4 B SP straight thread with check valve
<b>3</b>	7/16-20UNF-2B SAE O-ring port with check valve

**15 Low pressure relief**  
**0** None

**16 17 Pressure/flow option**  
**00** None

**18 Geroler option**  
**0** Standard

**19 Seal option**  
**0** Standard

**20 21 Accessories**  
**00** None

**22 23 Special features (hardware)**  
**00** None

**24 25 Special features (assembly)**  
**00** None (Standard)

**26 27 Paint/packaging**  
**AA** Blue  
**AB** Black

**28 29 Customer identification or name plate**  
**00** None

**30 Design code**  
**A** First

\* For more special features contact your Danfoss representative .

# XL6 Series

## Highlights

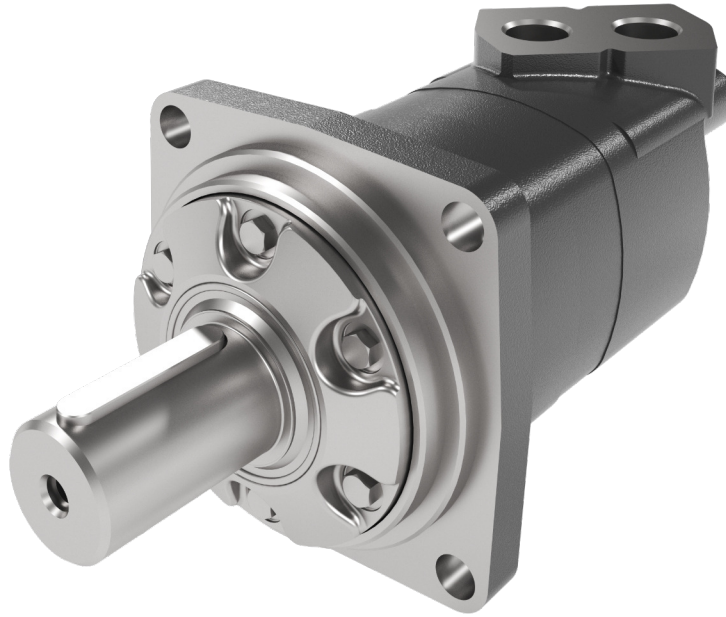

## Description

Danfoss' Xcel™ Series Low Speed High Torque Disc Valve motors offer the most popular features and options from the parallel Danfoss Char-Lynn range and are optimized to bring the highest value in medium duty applications.

### Features

- 8 displacements, a variety of mounting flanges and output shafts
- Reliable, proven design
- High efficiency

### Benefits

- Flexibility in designing this motor into a system
- Options that fit well into tough applications

### Applications

- Mobile Equipment
- Snow Removal, Mowing
- Sprayers
- Trenching Machines
- Wood Processing Machines

### XL6 Series Motors

Geroler® Element	8 Displacements
Flow l/min [GPM]	150 [40] Continuous** 225 [60] Intermittent*
Speed RPM	775 Cont.** 866 Inter.*
Pressure bar [psi]	205 [3000] Cont.** 310 [4500] Inter.*
Torque Nm [lb-in]	1685 [14920] Cont.** 1875 [16580] Inter.*

\*\* Continuous— (Cont.) Continuous rating, motor may be run continuously at these ratings

\* Intermittent— (Inter.) Intermittent operation, 10% of every minute



# XL6 Series

## Specifications

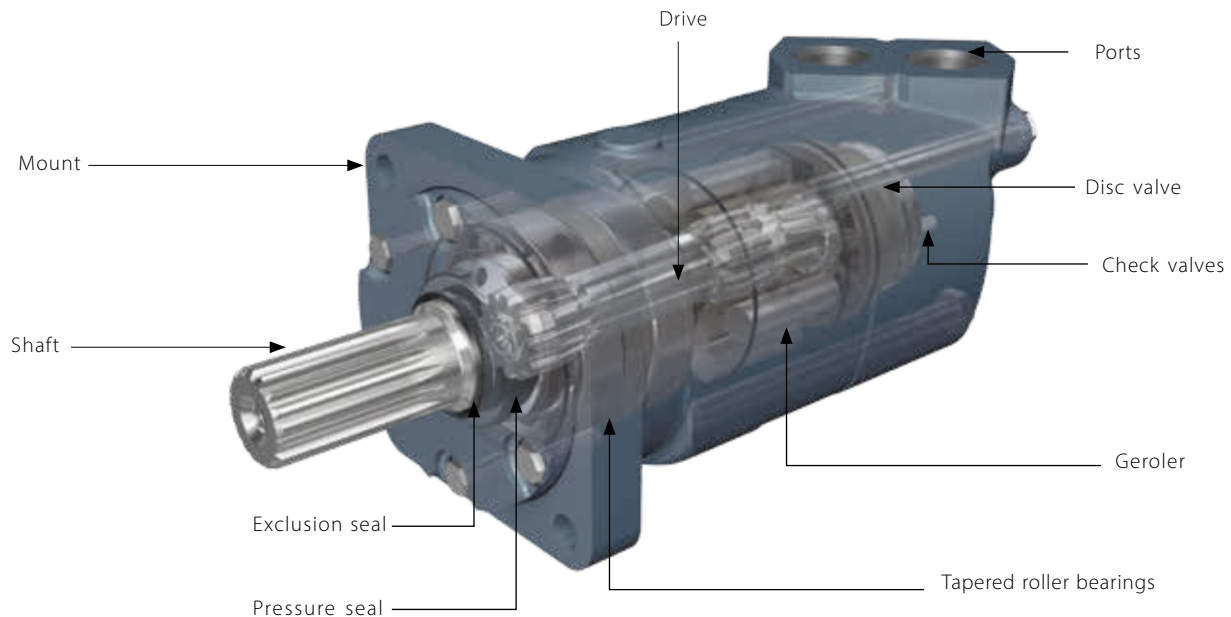

### Specification Data

Displacement cm <sup>3</sup> /r [in <sup>3</sup> /r]		195 [11.9]	245 [15.0]	310 [19.0]	390 [23.9]	490 [30.0]	625 [38.0]	805 [49.0]	985 [60.0]
Flow LPM [GPM]	Continuous	150 [40]	150 [40]	150 [40]	150 [40]	150 [40]	150 [40]	150 [40]	150 [40]
	Intermittent	170 [45]	210 [55]	225 [60]	225 [60]	225 [60]	225 [60]	225 [60]	225 [60]
Max. Speed RPM	Continuous	775	615	485	387	307	241	187	153
	Intermittent	866	834	698	570	454	355	280	230
Pressure ΔBar [Δpsi]	Continuous	205 [3000]	205 [3000]	205 [3000]	205 [3000]	205 [3000]	170 [2500]	140 [2000]	140 [2000]
	Intermittent	310 [4500]	310 [4500]	310 [4500]	310 [4500]	275 [4000]	221 [3200]	170 [2500]	140 [2000]
Torque* Nm [lb-in]	Continuous	575 [5100]	735 [6510]	930 [8230]	1155 [10230]	1445 [12800]	1480 [13100]	1582 [14004]	1685 [14920]
	Intermittent	860 [7620]	1100 [9740]	1355 [11990]	1635 [14490]	1885 [16670]	1898 [16800]	1850 [16377]	1875 [16580]
Weight Kg [lbs]	Standard or wheel mount	24.9 [55.0]	25.2 [55.5]	25.6 [56.5]	26.3 [58.0]	27.0 [59.5]	27.9 [61.5]	29.0 [64.0]	30.4 [67.0]
	Bearingless	20.2 [44.5]	20.4 [45.0]	20.9 [46.0]	21.5 [47.5]	22.2 [49.0]	23.1 [51.0]	24.5 [53.5]	25.7 [56.5]

Maximum Case Pressure: See case pressure seal limitation graph \*See shaft torque ratings for limitations .

**Note:** To assure best motor life, run motor for approximately one hour at 30% of rated pressure before application to full load . Be sure motor is filled with fluid prior to any load applications .

#### Max. inlet pressure:

310 bar [4500 psi]  
Do not exceed Δ pressure rating (see chart above).

#### Max. return pressure:

310 bar [4500 psi] with case drain line installed .  
Do not exceed Δ pressure rating (see chart above).

#### ΔBar [Δpsi]:

The true pressure difference between inlet port and outlet port .

#### Continuous rating:

Motor may be run continuously at these ratings .

#### Intermittent operation:

10% of every minute .

#### Recommended fluids:

Premium quality, antiwear type hydraulic oil with a viscosity of not less than 13 cSt (70 SUS) at operating temperature .

#### Recommended system operating temp.:

-34°C to 82°C [-30°F to 180°F]

#### Recommended filtration

per ISO Cleanliness Code, 4406: 20/18/13

# XL6 Series

## Performance Data

Function Diagram: XL6 motor 195 cc

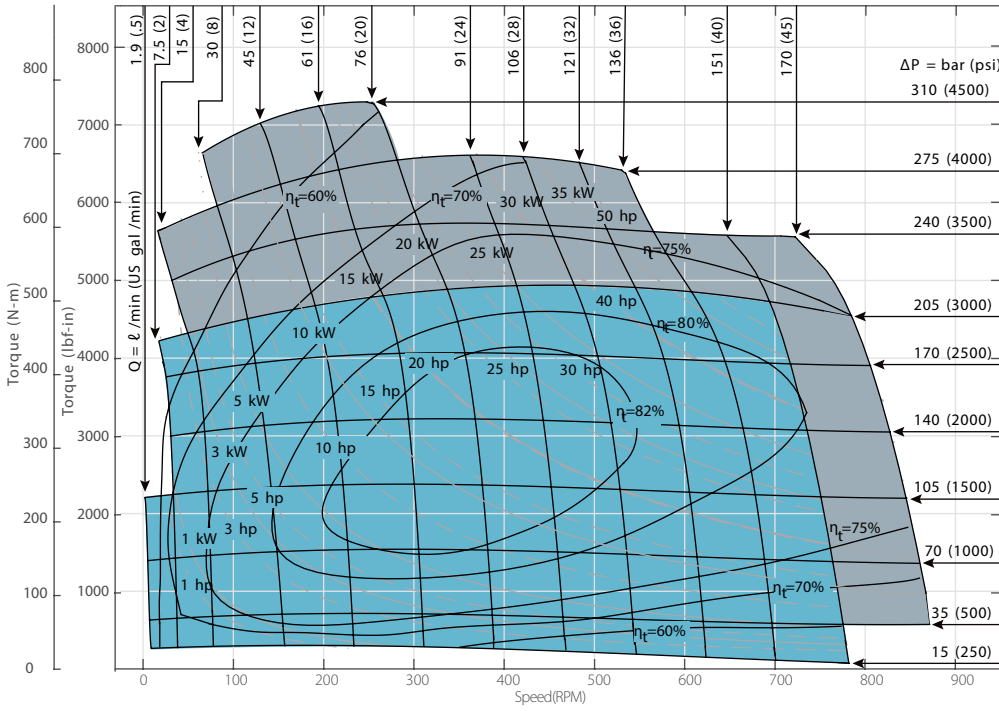

Performance data is typical at 25 cSt (120 SUS). Actual data may vary slightly from unit to unit in production.

$\eta_t$  = overall efficiency

- Continuous
- Intermittent

Function Diagram: XL6 motor 245 cc

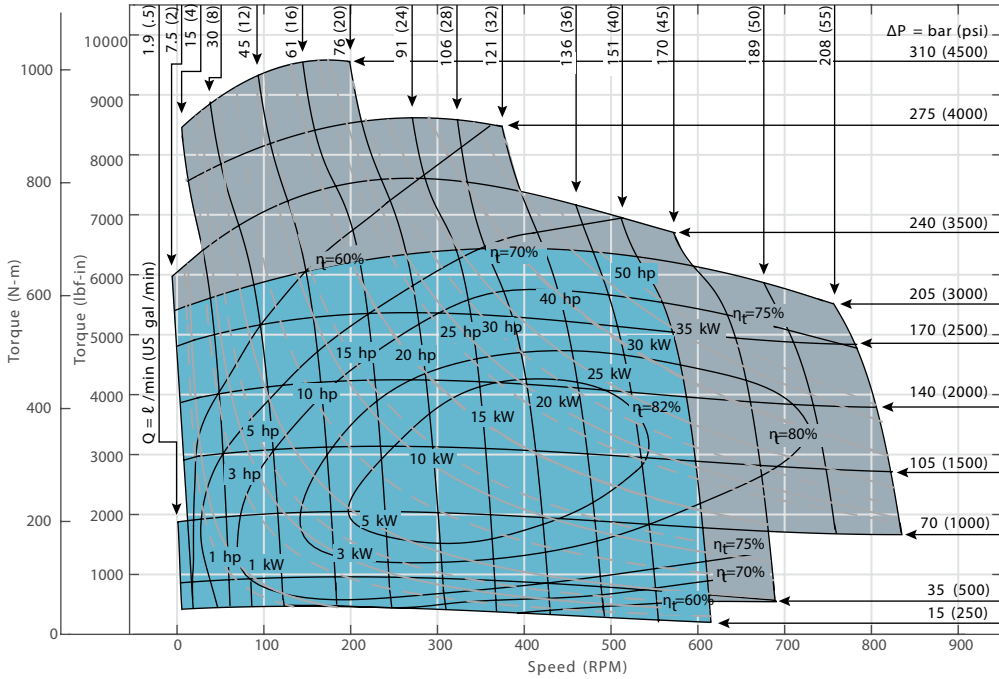

# XL6 Series

## Performance Data

Function Diagram: XL6 motor 310 cc

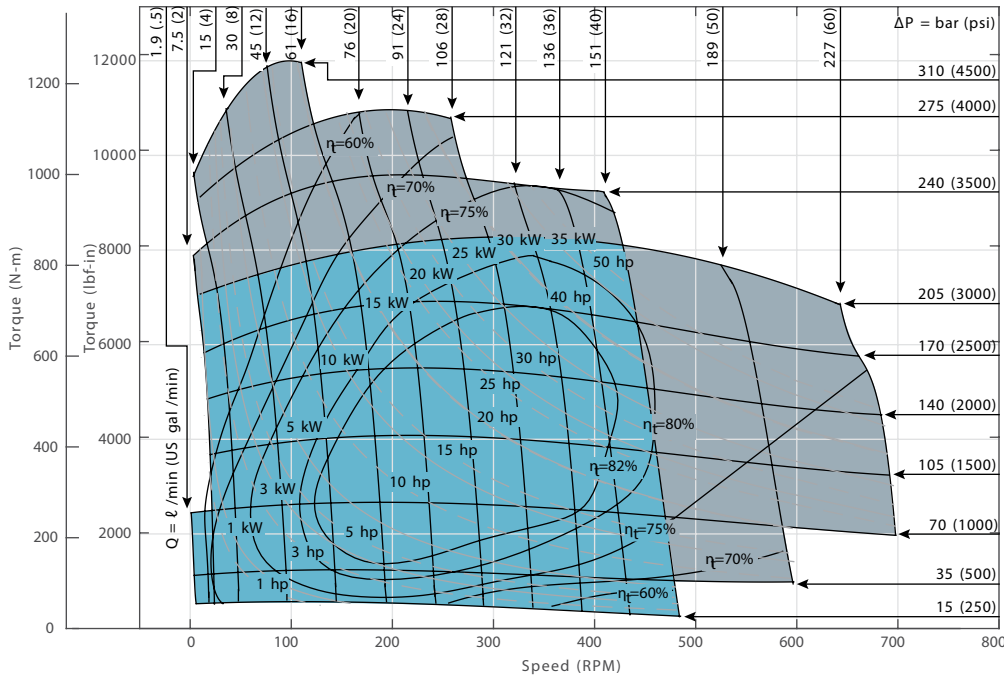

Performance data is typical at 25 cSt (120 SUS). Actual data may vary slightly from unit to unit in production.

$\eta_t$  = overall efficiency

Continuous

Intermittent

Function Diagram: XL6 motor 390 cc

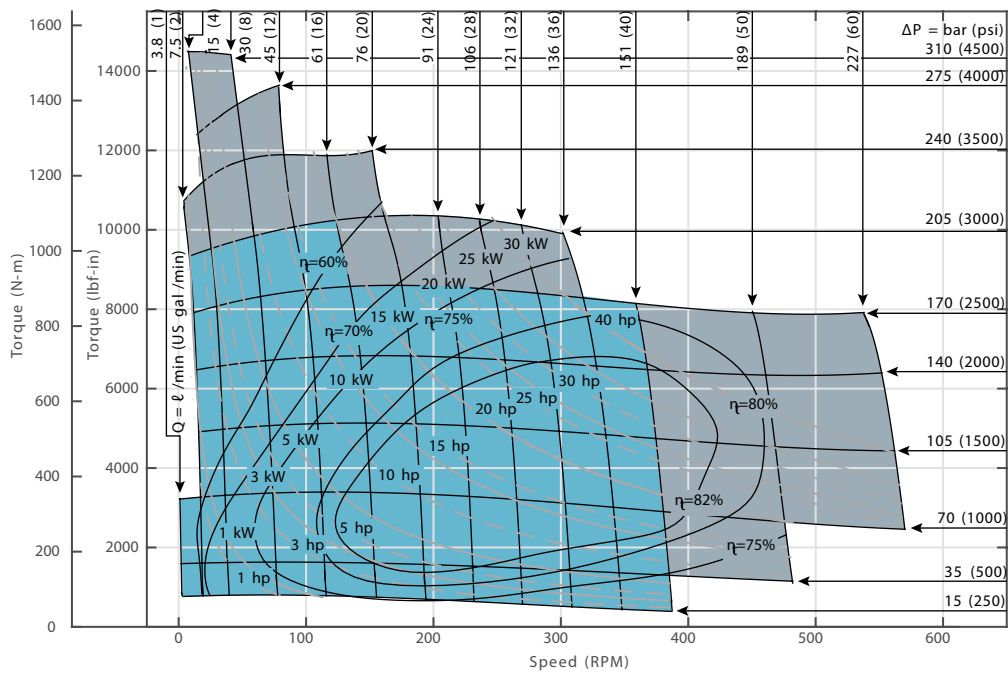

# XL6 Series

## Performance Data

**Function Diagram: XL6 motor 490 cc**

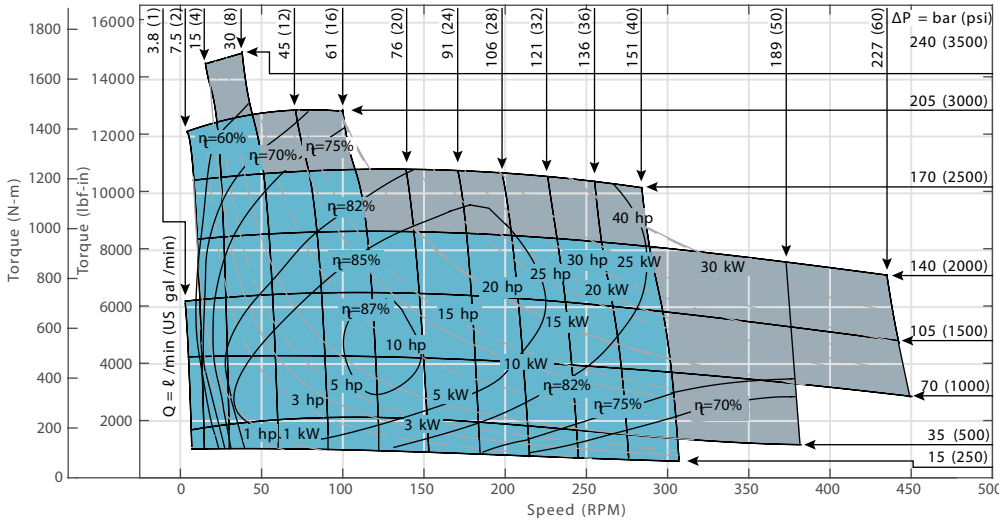

Performance data is typical at 25 cSt (120 SUS). Actual data may vary slightly from unit to unit in production.

$\eta_t$  = overall efficiency

- Continuous
- Intermittent

**Function Diagram: XL6 motor 625 cc**

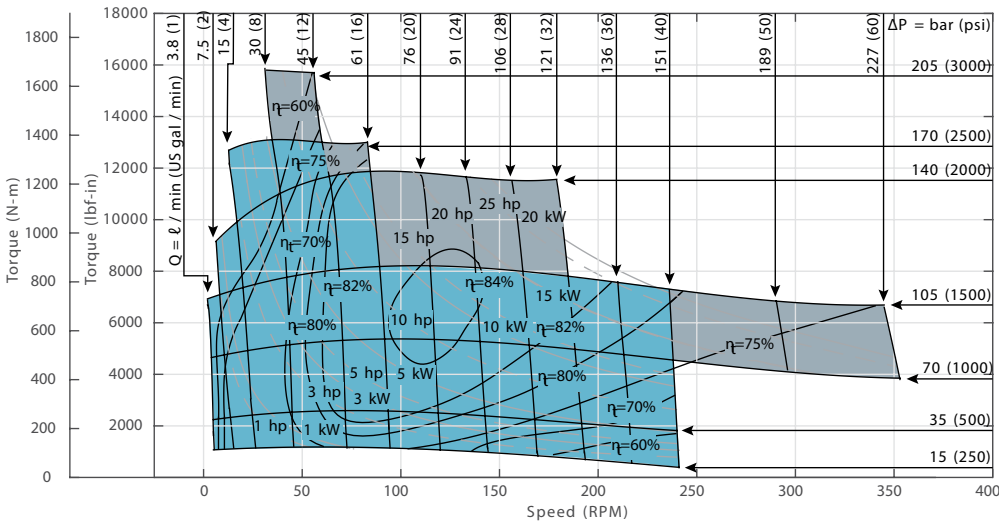

# XL6 Series

## Performance Data

Function Diagram: XL6 motor 805 cc

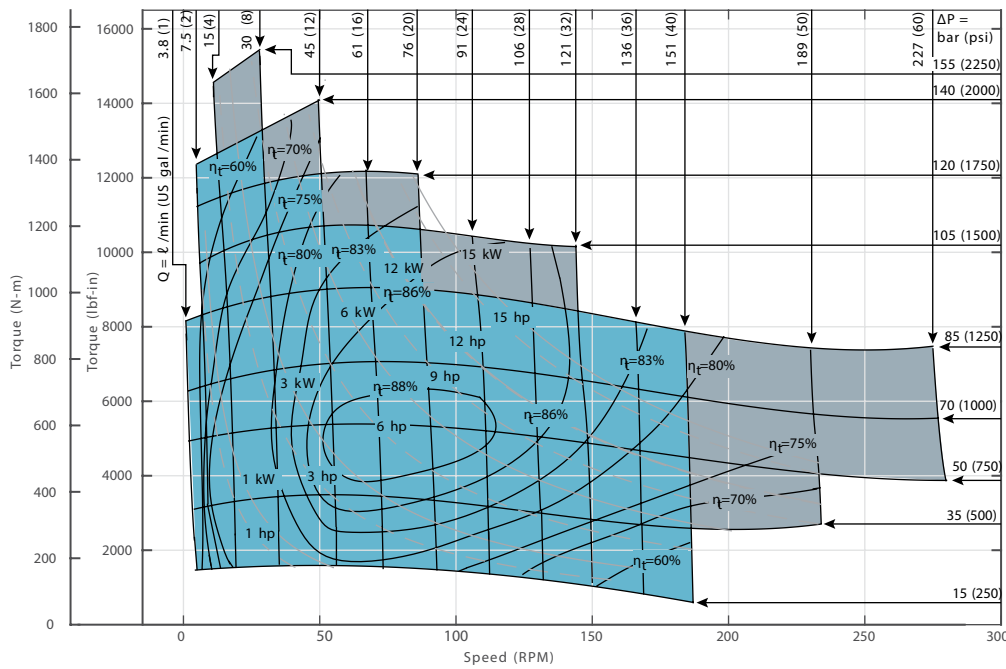

Performance data is typical at 25 cSt (120 SUS). Actual data may vary slightly from unit to unit in production.

$\eta_t$  = overall efficiency

Continuous

Intermittent

Function Diagram: XL6 motor 985 cc

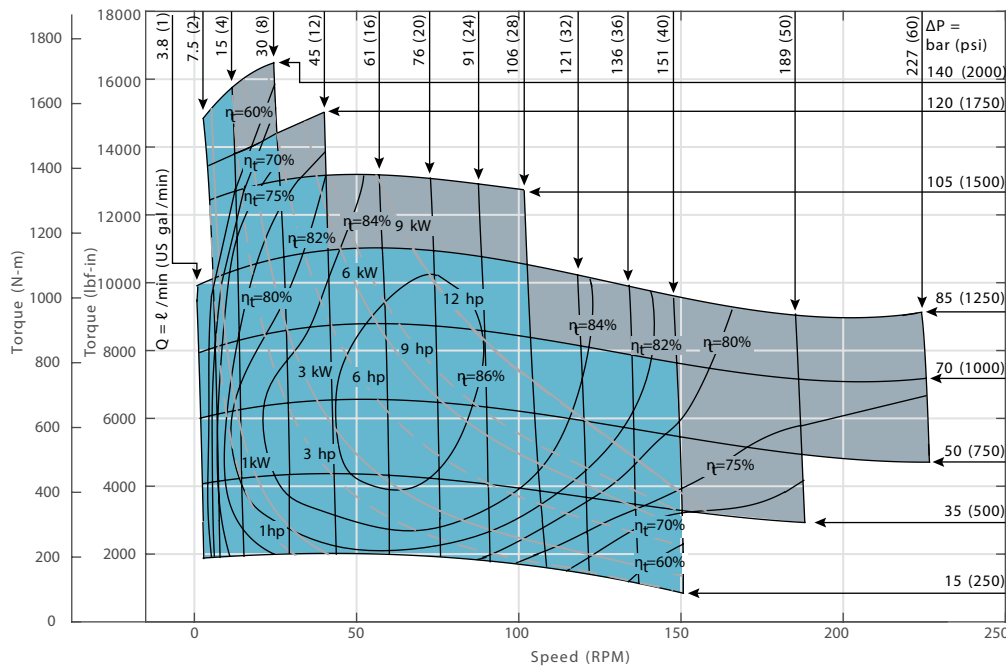

# XL6 Series

## Dimensions - Standard/Wheel Mount

### Ports

- 1 5/16 -12 UN-2B SAE O-ring Staggered Ports (2)
- 7/16 -20 UNF-2B SAE O-ring Case Drain Port (1) or
- G 1 (BSP) Staggered Ports (2)
- G 1/4 (B SP) Case Drain Port (1)

### Standard Rotation Viewed from Shaft End

- Port A Pressurized — CW
- Port B Pressurized — CCW

### Standard Mount (AB)

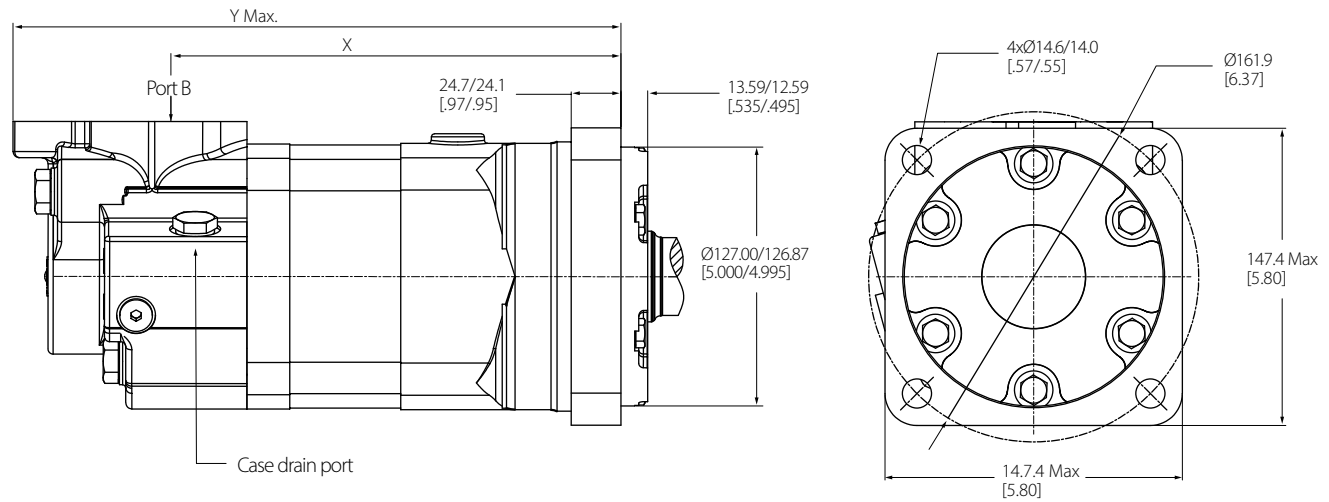

Standard mount (AB) motor dimensions

Displacement	X		Y	
	mm	[inch]	mm	[inch]
195 [11.9]	187.5	[7.38]	270.0	[10.63]
245 [15.0]	193.0	[7.60]	275.6	[10.85]
310 [19.0]	200.1	[7.89]	283.0	[11.14]
390 [23.9]	209.0	[8.23]	291.6	[11.48]
490 [30.0]	220.2	[8.67]	302.8	[11.93]
625 [38.0]	235.0	[9.25]	317.5	[12.50]
805 [49.0]	254.8	[10.03]	337.3	[13.28]
985 [60.0]	274.6	[10.81]	357.1	[14.06]

### Ports

- 1 5/16 -12 UN-2B SAE O-ring Staggered Ports (2)
- 7/16 -20 UNF-2B SAE O-ring Case Drain Port (1) or
- G 1 (BSP) Staggered Ports (2)
- G 1/4 (B SP) Case Drain Port (1)

### Standard Rotation Viewed from Shaft End

- Port A Pressurized — CW
- Port B Pressurized — CCW

### Wheel Mount (AC)

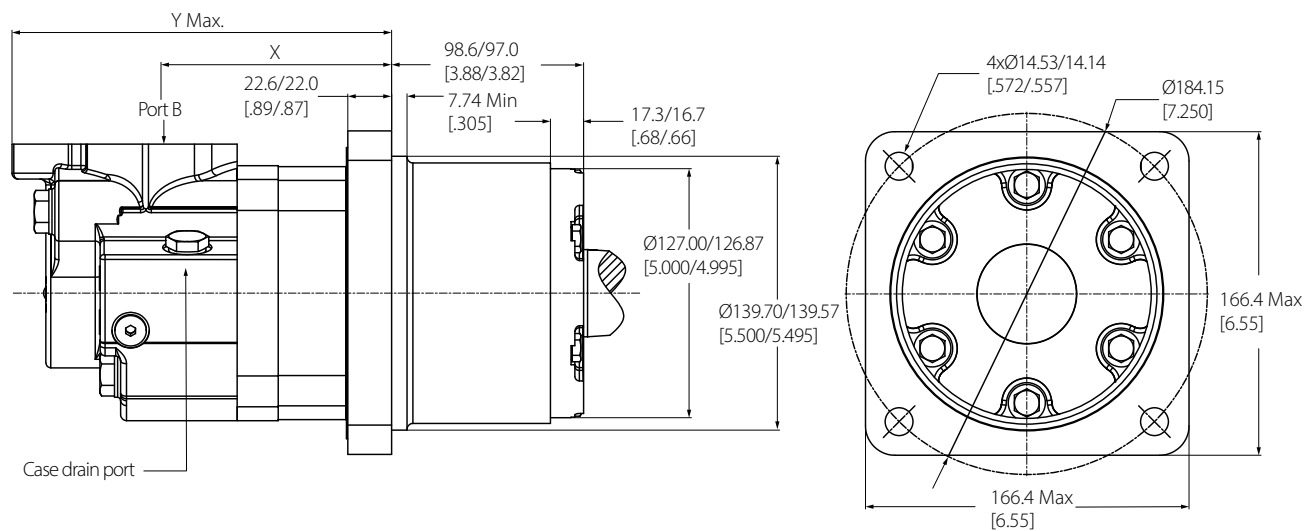

**Wheel mount (AC) motor dimensions**

Displacement cm <sup>3</sup> /r [in <sup>3</sup> /r]	X		Y		
	mm	[inch]	mm	[inch]	
195	[11.9]	102.6	[4.04]	185.2	[7.29]
245	[15.0]	108.2	[4.26]	190.8	[7.51]
310	[19.0]	115.6	[4.55]	198.1	[7.80]
390	[23.9]	124.5	[4.90]	207.1	[8.15]
490	[30.0]	135.4	[5.33]	217.9	[8.58]
625	[38.0]	150.1	[5.91]	232.7	[9.16]
805	[49.0]	169.9	[6.69]	252.7	[9.95]
985	[60.0]	189.7	[7.47]	272.5	[10.73]

# XL6 Series

## Dimensions-Global Mount (ISO)

### Ports

- 1 5/16 -12 UN-2B SAE O-ring Staggered Ports (2)
- 7/16 -20 UNF-2B SAE O-ring Case Drain Port (1) or
- G 1 (BSP) Staggered Ports (2)
- G 1/4 (B SP) Case Drain Port (1)

### Standard Rotation Viewed from Shaft End

- Port A Pressurized CW
- Port B Pressurized CCW

### Global Mount (ISO) (AH)

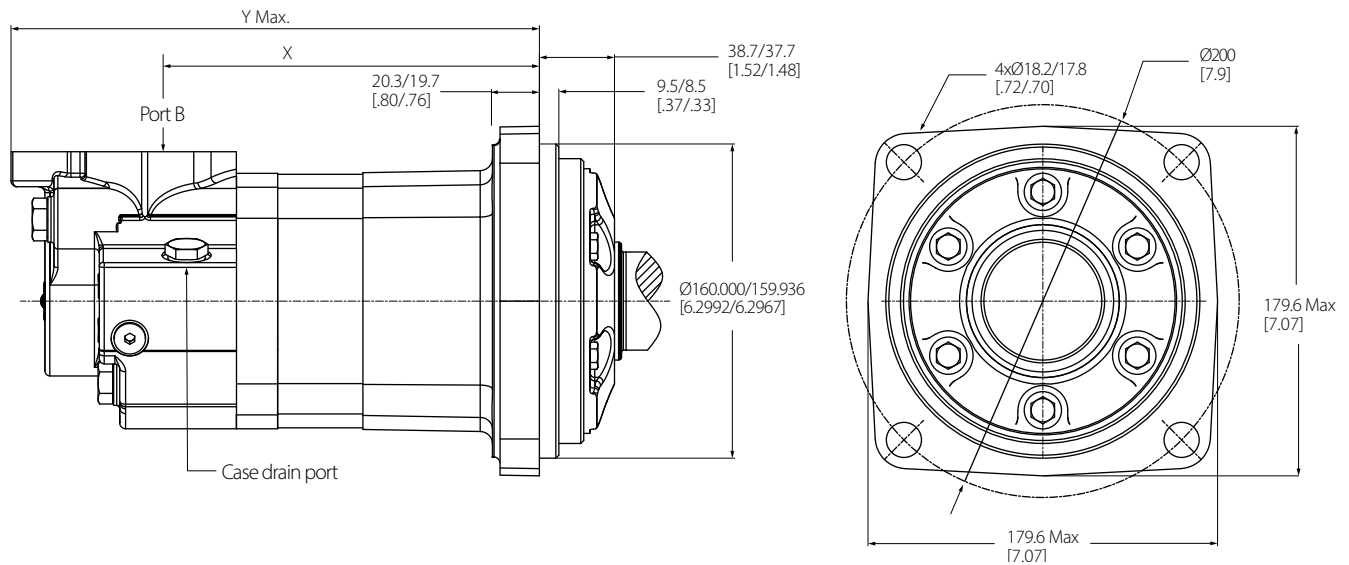

**Global mount (AH) motor dimensions**

Displacement	X		Y	
	mm	[inch]	mm	[inch]
310	[19.0]	182.4	[7.18]	264.9
390	[23.9]	191.0	[7.52]	273.6
490	[30.0]	202.2	[7.96]	284.7
625	[38.0]	216.9	[8.54]	299.5
805	[49.0]	236.7	[9.32]	319.3
985	[60.0]	256.5	[10.10]	339.1



### Ports

1 5/16-12 UN-2B SAE O-ring Staggered ports (2)  
 7/16-20 UNF-2B SAE O-ring Case Drain Port (1) or  
 G 1 (BSP) Staggered Ports (2)  
 G 1/4 (B SP) Case Drain Port (1)

### Standard Rotation Viewed from Shaft End

Port A Pressurized CW

Port B Pressurized CCW

### Bearingless Mount (AA)

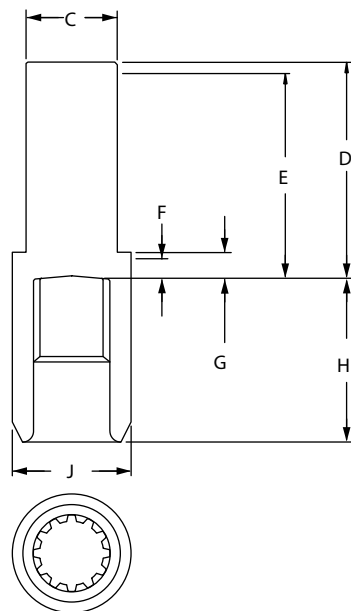
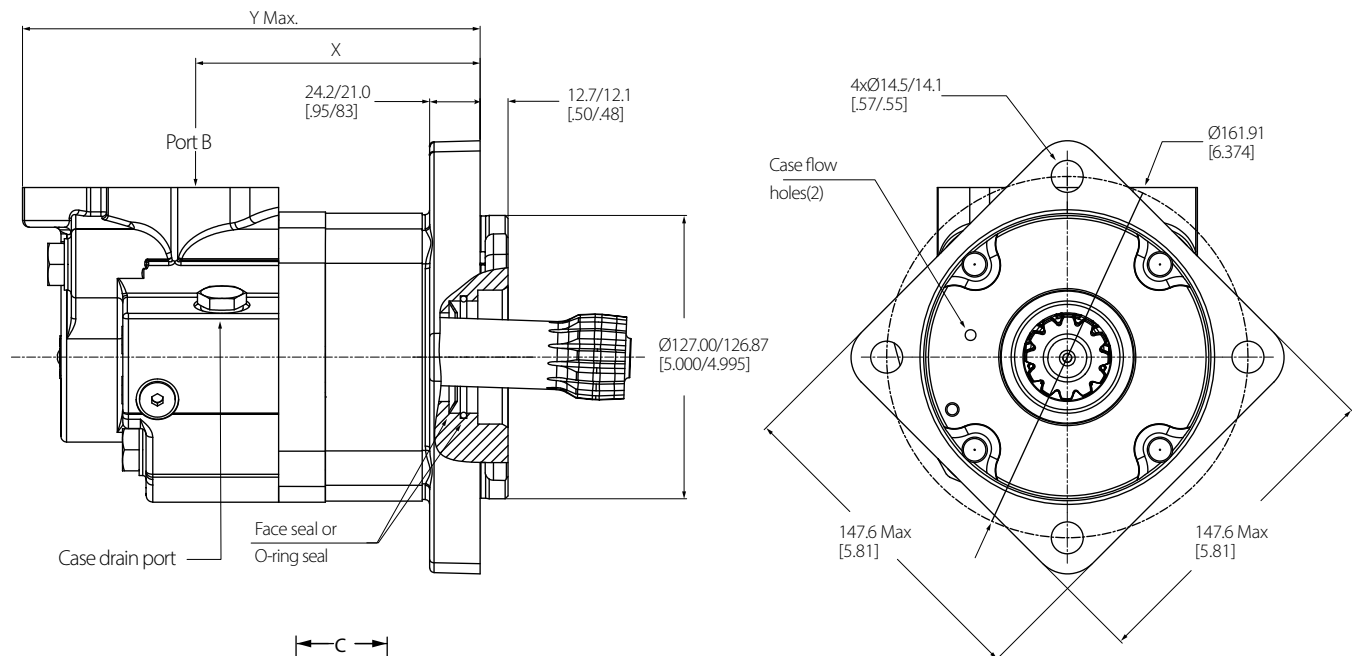

- C 47.2 [1.86] Dia.
- D 111.5 [4.39] Max.
- E 106.4 [4.19] Full form dia.
- F 6.9 [.27] Min. full form dia
- G 10.2 [.40] Min.
- H 86.1 [3.39] Max.
- J 66.5 [2.62] Dia.

Mating Coupling Blank  
 Danfoss Part No. 12778-002

Bearingless mount (A A) motor dimensions

Displacement	X		Y		
	mm	[inch]	mm	[inch]	
195	[11.9]	105.4	[4.15]	188.0	[7.40]
245	[15.0]	111.0	[4.37]	193.5	[7.62]
310	[19.0]	118.4	[4.66]	200.9	[7.91]
390	[23.9]	127.3	[5.01]	209.6	[8.25]
490	[30.0]	138.2	[5.44]	220.7	[8.69]
625	[38.0]	152.9	[6.02]	235.5	[9.27]
805	[49.0]	173.0	[6.81]	255.3	[10.05]
985	[60.0]	192.8	[7.59]	275.1	[10.83]

For Xcel XL6 Series bearingless motor application information, contact your Danfoss representative (mating coupling blanks available from Danfoss).

**Note:** After machining blank, part must be hardened per Danfoss specification .

# XL6 Series

## Installation information Bearingless

- ① Internal spline in mating part to be as follows: Material to be ASTMA304, 8620H . Carbonize to a hardness of 60-64 HRc with case depth (to 50HRc) of 0,076 - 1,02 [ .030 - .040] (dimensions apply after heat treat) .
- ② Mating part to have critical dimensions as shown . Oil holes must be provided and open for proper oil circulation .
- ③ Seal to be furnished with motor for proper oil circulation .
- ④ Some means of maintaining clearance between shaft and mounting flange must be provided .
- ⑤ Similar to SAE "C" four bolt flange .
- ⑥ Counterbore designed to adapt to a standard sleeve bearing 50,010 - 50,038 [1.9689 - 1.9700] ID by 60,051 - 60,079 [2.3642 - 2.3653] O .D . (Oilite bronze sleeve bearing) .

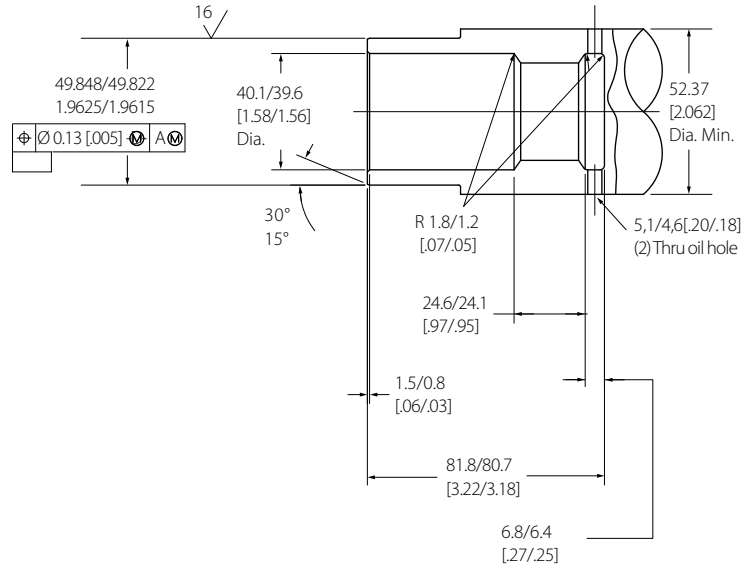
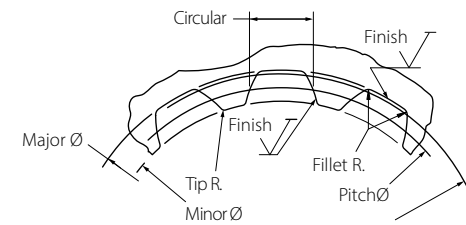
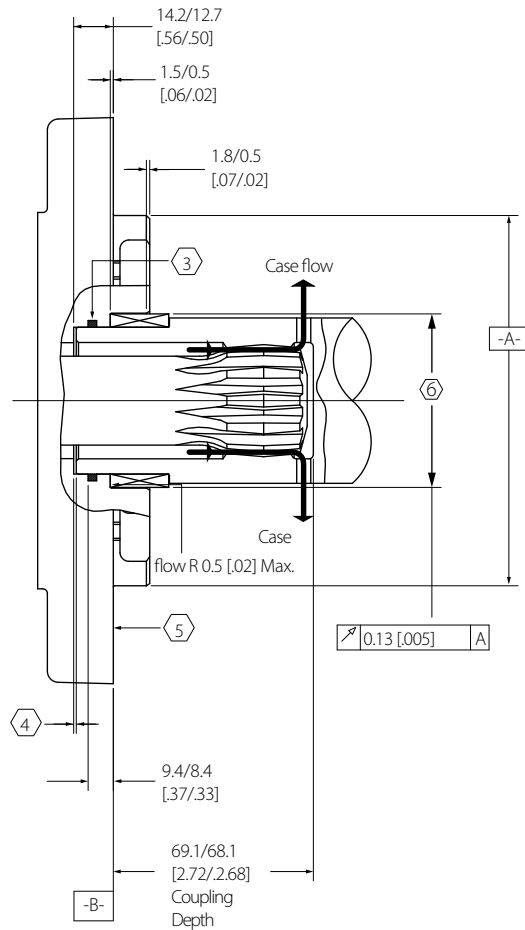

Spline Pitch	8.5/17
Pressure Angle	30°
Number of teeth	12
Class of Fit	Ref. 5
Type of Fit	Side
Pitch Diameter	Ref. 35.858823 [1.4117647] $\sqrt{0.20[.008] D}$
Base Diameter	Ref. 31.054652 [1.2226241]
Major Diameter	39.17 [1.542] Max. 38.97 [1.534] Min.
Min. Minor Diameter	33.30 - 33.48 [1.311 - 1.318]
Form Diameter, Min	38.33 [1.509]
Fillet Radius	0.64 - 0.76 [.025 - .030]
Tip Radius	0.25 - 0.51 [.010 - .020]
Finish	1.6 (63)
Involute Profile Variation	+0.000 -0.025 [+0.0000 -0.0010]
Total Index Variation	0.038 [.0015]
Lead Variation	0.013 [.0005]
<b>Circular Space Width:</b>	
Maximum Actual	5.898 [.2322]
Minimum Effective	5.804 [.2285]
Maximum Effective	Ref. 5.857 [.2306]
Minimum Actual	Ref. 5.834 [.2297]
Dimension Between Two Pins	Ref. 26.929 - 27.084 [1.0602 - 1.0663]
Pin Diameter	6.223 [.2450] Pins to have 4.0 [.160] Wide Flat for Root Clearance

### 38.1[1.50] Straight (01)

1328 N-m[11750 lb-in] M ax . torque

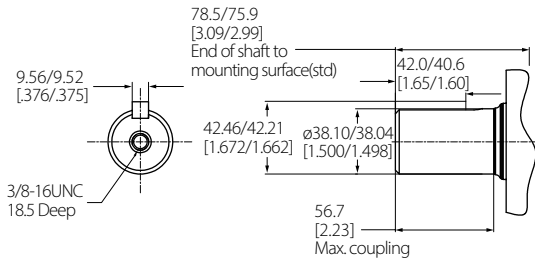

### 44.4[1.75] Tapered (02)

2107 N-m[18650 lb-in] M ax . torque

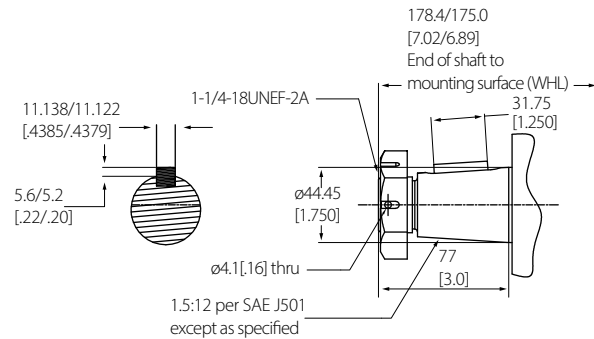

### 38.1[1.50] 17 Tooth splined (03)

1328 N-m[11750 lb-in] M ax . torque

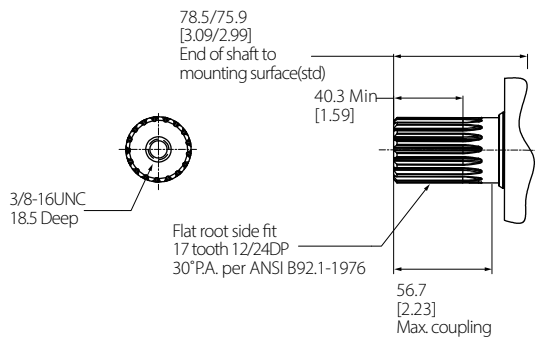

### 40 mm Straight (04)

1328 N-m[11750 lb-in] M ax . torque

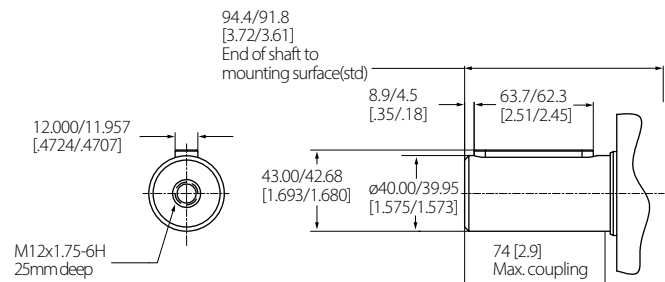

### 50 mm Straight (12)\*

2107 N-m[18650 lb-in] M ax . torque

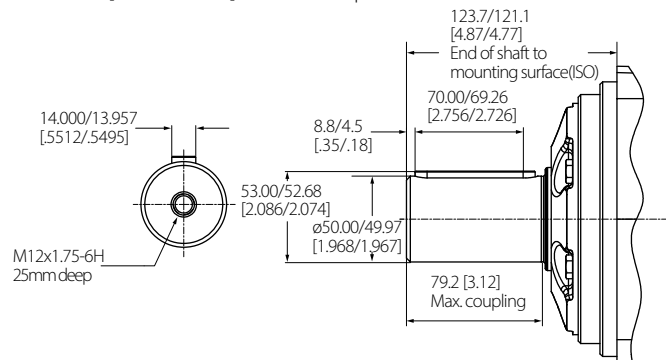

\* Just for mounting option "AH"

# XL6 Series

## Dimensions Ports

### Ports

1 5/16-12 UN-2B SAE O-ring Staggered ports (2)-**AA**

7/16-20 UNF-2B SAE O-ring Case Drain Port (1)-**02**

**or**

G 1 (BSP) Staggered Ports (2) – **AC**

G 1/4 (B SP) Case Drain Port (1) – **03**

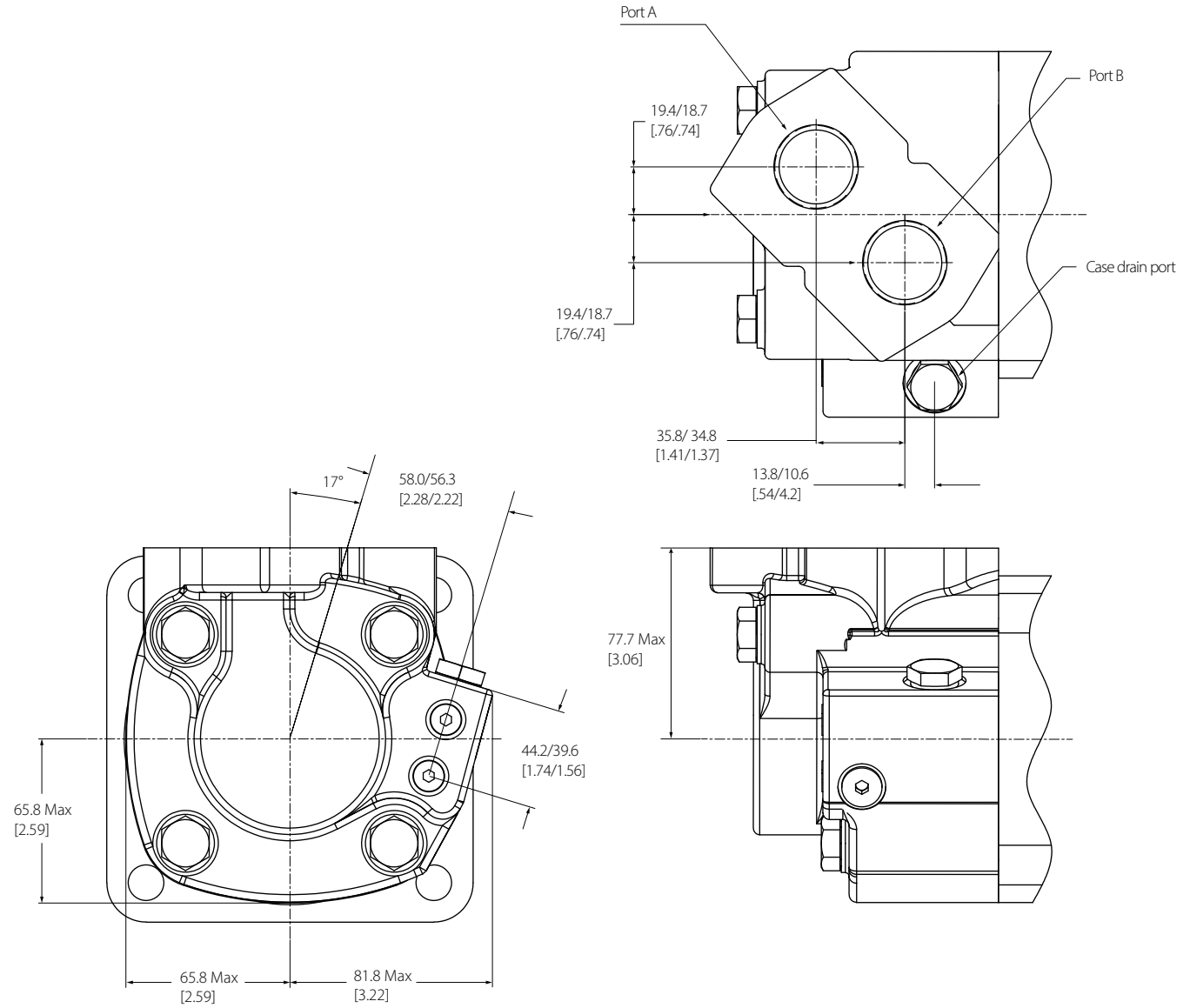

These curves indicate the radial load capacity on the motor shaft(s) at various locations with an external thrust load of 454 kg [1000 lb] . The maximum allowable thrust load is 908 kg [2000 lb] .

**Note:** Note: Case pressure will increase the allowable inward thrust load and decrease the allowable outward thrust load . Case pressure will push outward on the shaft at 109 kg/7 Bar [241 lb/100 PSI] .

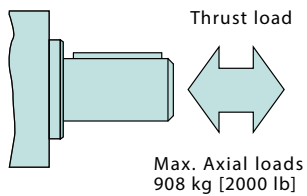

**Each curve is based on B 10 bearing life (2000 hours of 12,000,000 shaft revolutions at 100 RPM) at rated output torque . To determine radial load at speeds other than 100 RPM , multiply the load values given on the bearing curve by the factors in the chart below**

RPM	Multiplication Factor
50	1.23
100	1.00
200	0.81
300	0.72
400	0.66
500	0.62
600	0.58
700	0.56
800	0.54

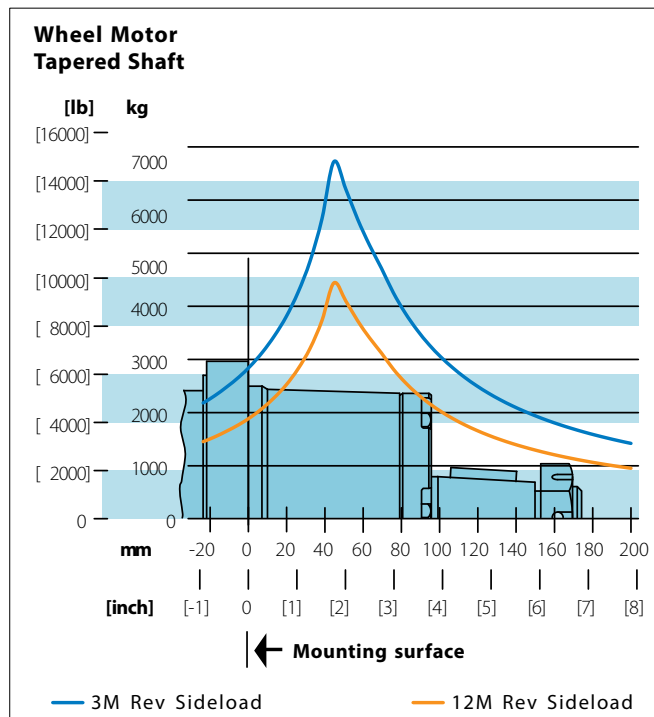
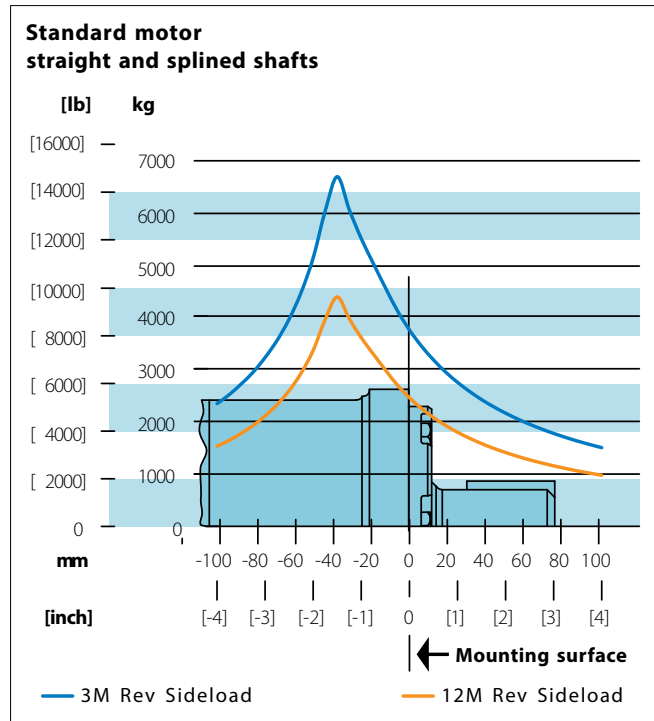

For 3,000,000 shaft revolutions or 500 hours—Increase these shaft loads 52%.

# XL6 Series

## Case pressure and case port

Xcel XL6 Series motors are durable and have long life as long as the recommended case pressure is not exceeded. Allowable case pressure is highest at low shaft speeds. Consequently, motor life will be shortened if case pressure exceeds these ratings (acceptability may vary with application). Determine if an external case drain is required from the case pressure seal limitation chart.

### Case porting advantage

**Contamination Control-** flushing the motor case. **Cooler motor-** exiting oil draws motor heat away. **Extend motor seal life-** maintain low case pressure with a preset restriction in the case drain line.

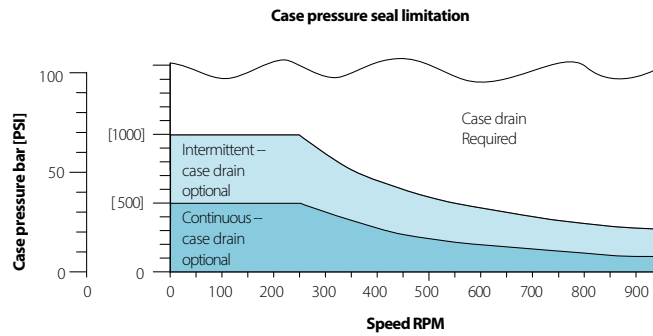

# XL6 Series

Model Code

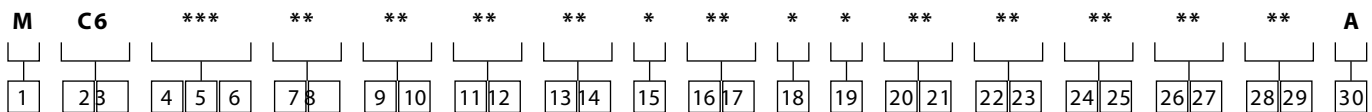

**1** **Product**  
**M** Motor

**2** **3** **Series**  
**C6** Xcel XL6 Series

<b>4</b>	<b>5</b>	<b>6</b>	<b>Displacement</b>	<b>cm<sup>3</sup>/rev</b>	<b>[in<sup>3</sup>/r]</b>
<b>195</b>	195	.8 [11 .95]			
<b>245</b>	246	.5 [15 .04]			
<b>310</b>	312	.0 [19 .04]			
<b>390</b>	391	.7 [23 .90]			
<b>490</b>	491	.4 [29 .99]			
<b>625</b>	624	.2 [38 .09]			
<b>800</b>	803	.4 [49 .03]			
<b>985</b>	982	.7 [59 .97]			

**7** **8** **Mounting description**

**AA** Bearingless, 4 bolt: 127.0 [5 .00] Pilot DIA . 14 .35 [.565] Dia . Holes on 162 .0 [6 .38] DIA . bolt circle

**AB** Standard, (SAE CC), 4 bolt: 127.0 [5 .00] Pilot DIA . 14 .35 [.565] DIA . Holes on 162 .0 [6 .38] DIA . bolt circle

**AC** W heel, 4 bolt: 139 .7 [5 .50] Pilot DIA . 14 .35 [.565] DIA . Holes on 184 .2 [7.25] DIA . bolt circle

**AH** Standard, 4 bolt: 160 .0 [6 .30] Pilot DIA . 18 .01 [.709] DIA . Holes on 200 .0 [7.87] DIA . bolt circle

**9** **10** **Output shaft description**

**0** None (bearingless)

**1** 38 .10 [1 .500] DIA . straight shaft with .375 - 16 UNC-2B thread in end, 9 .52 [.375] Sq x 41 .28 [1 .625] straight key

**2** 44 .45 [1 .750] DIA . .125:1 Tapered shaft per SAE J501 with 1 .250-18 UNEF-2A threaded shaft end, 11 .11 [.4375] Sq .X 31 .8 [1 .25] straight key

**3** 38 .10 [1 .500] DIA . flat root side fit, 17 tooth, 12/24 DP 30 deg . involute spline with .375-16 UNC-2B thread in end 40 .4 [1 .59] minimum full spline length

**4** 40 .00 [1 .575] Dia . straight shaft with M12 x 1 .75-6H thread in end, 12W x 8H x 63L [.472W x .313H x 2 .480L] key

**12** 49 .99 [1 .968] DIA . straight shaft with M12 x 1 .75-6H thread in end, 14W x 9H x 70L [.550W x .354H x 2 .756L] key

**11** **12** **Port description**

**AA** 1.3125-12 UN-2B SAE O-ring ports-staggered ports

**AC** G 1 staggered ports

**13** **14** **Case flow options**

**2** .4375-20 UNF-2B SAE O-ring port with check valve

**3** G 1/4 BSP straight thread port with check valve

**15** **Low pressure relief**

**0** None

**16** **17** **Pressure/flow option**

**00** None

**18** **Geroler option**

**0** Standard

**19** **Seal option**

**0** Standard

**20** **21** **Accessories**

**00** None

**22** **23** **Special features (hardware)**

**00** None

**24** **25** **Special features (assembly)**

**00** None (Standard)

**26** **27** **Paint/packaging**

**AA** Blue

**AB** Black

**28** **29** **Customer identification or name plate**

**00** None

**30** **Design code**

**A** First

\* For more special features contact your Danfoss representative .