

Technical Information

# Counterbalance Valve Systems for H1B Motors in Open Circuits



**Revision history***Table of revisions*

<b>Date</b>	<b>Changed</b>	<b>Rev</b>
April 2024	Updated housing model code and suction port dimension	0202
November 2023	Added DN25A	0201
April 2023	Added DN32B	0102
October 2022	First edition	0101

**Contents****General information**

Function of the counterbalance valve.....	4
Theory of operation.....	4

**Specifications**

Technical data.....	5
CBV pressure drop characteristic.....	6
CBV port dimensions.....	6
CBV fluid and cleanliness.....	7

**Operation**

Main spool.....	9
Dampening.....	9
High pressure relief valves.....	10
Brake pressure release (port R).....	10
Flushing (port T).....	11
Suction / external charge (port S).....	11

**Master model code**

CBV model code breakdown.....	12
General product description.....	12
Main function.....	12
Special function.....	14
Settings and special hardware.....	14
CBV ordering information.....	16

**CBV installation****Safety information**

CBV safety guidelines.....	18
Recommended safety standards.....	18

**CBV dimensions**

## General information

### Function of the counterbalance valve

The counterbalance valve (CBV) serves as a protection function in open circuits. This is necessary because the machine cannot be supported by the diesel or electric engine as in closed circuits.

The target applications are wheeled or tracked vehicles (e.g. excavator) or working devices (e.g. lifting of drill heads on vertical drilling equipment), as well as other working functions with a rotor using hydrostatic variable or fixed motors.

The CBV protects the motor at downhill or pulling force modes (e.g. mulcher, drilling pipes). CBV consumes, in open circuit, the potential energy during the braking operation and converts it into heat. It prevents overspeeding of the motor and/or cavitation as soon as the speed induced by the machine exceeds the speed corresponding to the flow fed to the motor.

### Theory of operation

The counterbalance valve is designed as a symmetric spool valve.

The CBV is intended to be used as safety valve for applications such as traction motors in wheel or track excavators, as well as winch motors (no free hanging loads). They protect the hydromotor from exceeding overspeed or cavitation in the inlet side when driving downhill or when loads are dragging.

## Specifications

### CBV for H1B technical data

The following tables display mechanical specifications for the counterbalance valves.

#### General specifications

Design		Symmetric Spool Valve
Direction of shift		Bi-directional
Pipe connection	Main pressure ports	ISO 6162 split flange boss – distance according to best fit Danfoss motors
	Remaining ports	all threaded ports with flat elastomer sealing metric ISO 6149

#### Physical properties

Features	Unit	DN25A	DN32A	DN32B
Fits to Motor size with axial port end cap of H1B TC/PE	-	H1B80/110	H1B160	H1B 210/250
Weight dry	kg	15	15	15
Design flow at a max. back-pressure of 15 bar	l/min	300 l/min	400 l/min	400 l/min
Pressure reduction valve for brake release (if selected)	bar	21 (+7 tolerance)	21 (+7 tolerance)	21 (+7 tolerance)
Flushing (if applicable – 1.1mm orifice)	l/min	Max 7 @ 8 bar opening	Max 7 @ 8 bar opening	Max 7 @ 8 bar opening

#### Operating parameters

Parameter	unit	DN25A	DN32A/B
Rated operating pressure	bar	350	350
Max. working pressure	bar	420	420
Nominal flow	l/min	300	400
Max. flow	l/min	400	600

## Specifications

### CBV pressure drop characteristic

The pressure drop characteristic of the CBV is dependent on the spool option. The diagram reflects the spool characteristic, not the valve as a whole.

The diagram is based on the following:

- Oil viscosity = 30mm<sup>2</sup>/s
- Oil temperature = 50° C
- Brake piston fully open
- Piston option A40 (closed one) fully open for DN32A is used

Pressure drop characteristic

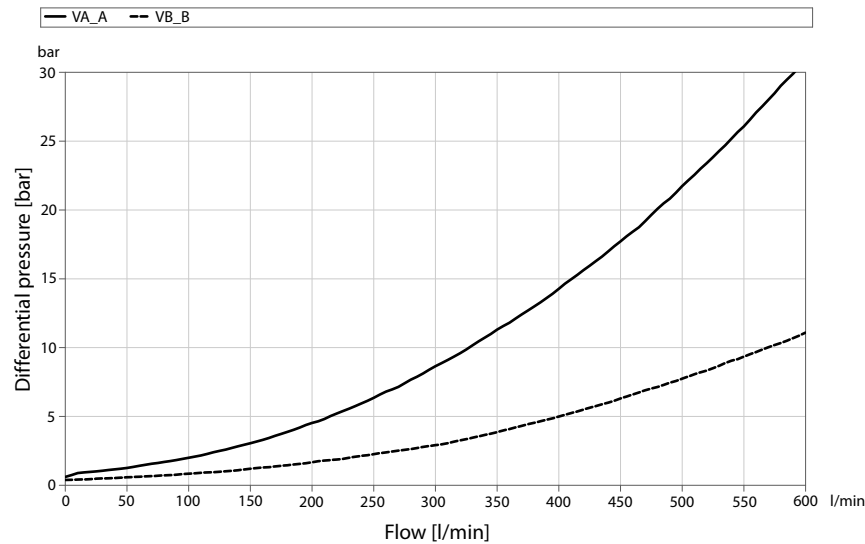

### CBV port dimensions

Both system components - CBV and bent axis motors - come along with metric ports. The table below displays the specification and labeling for the CBV.

System port labeling		DN25A	DN32A	DN32B
System Port	A/B	ISO 6162-2 P25M 4xM12	ISO 6162-2 P32M 4xM12	ISO 6162-2 P32M 4xM12
Brake release	R	ISO 9974-1 M14x1,5		
Flushing	T	ISO 9974-1 M14x1,5		
External charge / suction	S	ISO 9974-1 M27x2		
System ports towards motor	VA/VB	ISO 6162-2 P32M		

**Specifications****CBV fluid and cleanliness**

Both temperature and viscosity values shall be met for operating conditions listed in the table. Operating temperature and converted kinematic viscosity measured at hottest point of the unit (typically case drain fluid in the motor).

Parameter	Temperature [°C]	Viscosity [mm <sup>2</sup> /s]
Cold start	Minimum -20	500 max.
Recommended range	50 ...75	12...20
Continuous rating	Maximum 80	7 min.

At the lowest temperature, not all functions will be available or not as specified. At the highest temperature, the lifetime will decrease. The amount of decreased lifetime is variable due to significant impact from the application.

[Required system cleanliness level is ISO 4406 class 22/18/13 or better. Units as received can be expected to be at ISO 4406 class 25/22/17.](#)

---

**CBV operation**

The input flow (e.g. from A - it may also be the opposite port B. For the simplification we assume the installation to be such that port A is the high pressure side, it is symmetrical valve) is passing by a low pressure drop check valve (8.1) and goes directly into the motor via VA. The high pressure from the A side at the same time fully opens the CBV spool, the passage is designed for low pressure drop all over (see [CBV pressure drop characteristic](#) on page 6). This allows high vehicle speed at lower power losses.

The flow exiting the motor and entering valve port VB goes back to the tank via the spool of the CBV with only minimum resistance. In order to open the spool a minimum pressure delta of 10 bar (between A and B) is required. This pressure starts to push the spool to open and releases flow captured between motor and CBV towards the exit port B.

If the motor gets too fast, the CBV will suck more flow from the B line than delivered from the pump. In special cases, an external charge port S may feed additional flow into the CBV to enable a warmup under cold weather conditions or a prefilling of the system. However, with a pressure on A below delta 8bar, the counterbalance valve will close immediately and again capture the flow coming from the motor. This in turn leads to a pressure build up. This way, the counterbalance valve ensures that the motor will always get the necessary flow it needs. The motor is thus safe from cavitation.

As stated the spool starts to open at delta of 10 bar and is fully open at a delta of 40 bar. If the input pressure gets below 40 bar the spool starts to close and builds up a braking pressure on the other system flow side. The input pressure reduction caused by spool movement continues until the vehicle stops. To have no harsh stop, the last hub portion is damped. The damping behavior/timing can be regulated by orifices.

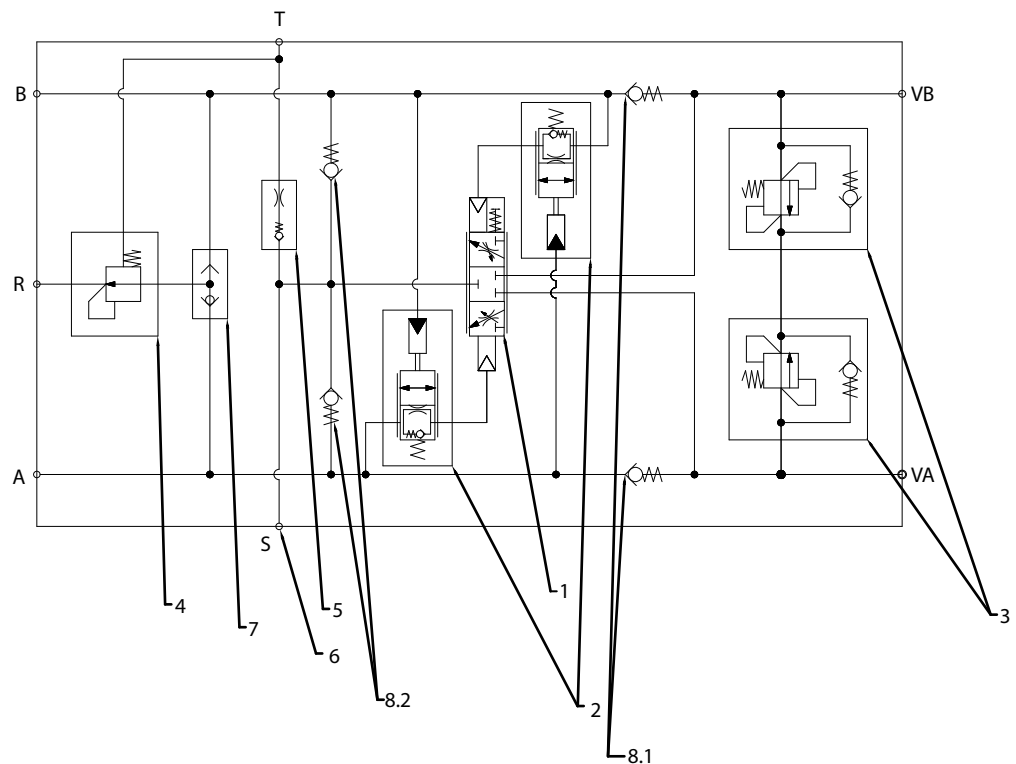

1. Main spool	6. Prefilling / charge / suction (port S)
2. Damping	7. Shuttle Valve
3. Relief valves	8.1. Input-check valve
4. Brake release (port R)	8.2. Output-check valve
5. Flushing (port T)	

Orientation: ports A and B is towards system; VA and VB is towards motor.



## CBV operation

### CBV main spool

The notches in the centered spool groove allow different flows to get e.g. from A to B port, which results in different braking behavior. It could be a closed or open spool in neutral position.

#### **Warning**

A closed spool is a **MUST** for winch application to minimize leakage. No free-rob winches are recommended with a CBV. Hanging loads are not allowed.

The closed spool holds the hoisted load in place before the mechanical brake will be active. While traveling, applications would most likely use the open configuration to get a non-abrupt stop.

If the desired flow is not within the range of the pistons supplied, please contact a Danfoss representative.

#### *Closed spool CBV*

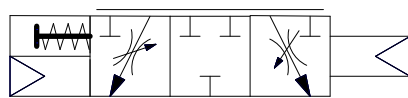

#### *Open spool CBV*

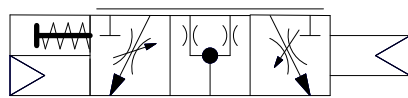

## CBV dampening

With the damping function in braking or acceleration mode, the different needs in combination with the spool type can be reached, from harsh/very intensive accelerating/braking behavior (very short accelerating/braking duration → large orifice areas) to weak/soft accelerating/braking behavior (long closing duration → small orifice areas).

In wheel excavator applications, a strong damping may be required; if the foot is taken off the accelerator, the excavator should slow down slowly and must not stop abruptly. For this request a damping is offered which only works with the clearance of the spool. In order to achieve a quick response (e.g. during operation at low oil temperature), the damping can temporarily be overridden by the high pressure relief valves (HPRVs).

For the use with track and winch drives, a brake valve with a damped opening and quick closing feature is recommended.

The high pressure spool side opens the check valve orifice acting at the centered linkage diameter on the opposite side. The check valve body leaves its seat and opens up for the flow coming out of the cavity where the spool is moving in.

The orifice acts when the cone is on its seat, pressed in by the high pressure, which acts on the spring side. The grooves of the main spool also have a high influence on the damping behavior.

**CBV operation**

**CBV high pressure relief valves**

HPRVs prevents pressure leaks in the system. Measurements of the pressures were done at the CBV inlet and outlet (ports VA and VB). If HPRVs are installed, they should not be used over 60 l/min because the drop curve rapidly increases at higher flows. Full flow will not be possible. The use of HPRVs will heat up the system, therefore proper sizing is required.

**CBV brake pressure release (port R)**

The brake pressure release (port R) allows the supply of high pressure / or reduced pressure from the shuttle for external brake release or for supplying another actuator or function. Two options are feasible: high pressure one or a reduced pressure for brake release.

The integrated pressure reduction valve is necessary when the mechanical brake on the gear unit cannot handle the full system pressure. The brake release valve limits the high pressure to 21 bar (with +7 bar tolerance). If no reduction valve is used, system pressure will be on port R.

**⚠ Warning**

When reduced brake release option (code L) is used, the flushing port must be connected/opened to motor case L1/L2 or tank of system. On delivery, the R port is plugged.

*System pressure*

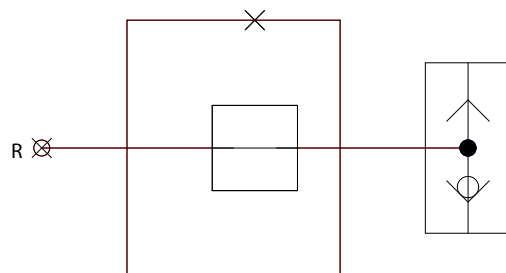

*Reduced pressure*

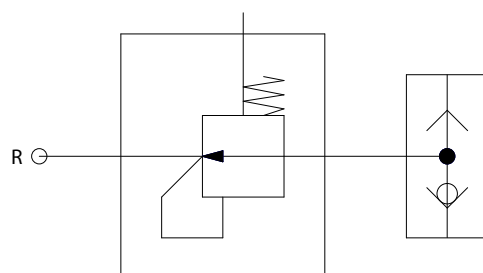

**CBV operation****CBV flushing (port T)**

The flushing port T at the CBV is used to ensure the motor housing is never without filling before the motor starts to avoid wear. This function is important when the reservoir is on a lower level than the system motor plus CBV. The T port of the CBV should be connected to the case drain port at the motor housing on its top position. This will work, when an open spool is used or the S port is used to feed oil in.

When reduced brake release option is used, it must be connected/opened to motor case, (plugged on delivery) to ensure proper function.

**CBV suction / external charge (port S)**

The external charge or suction port S may feed additional flow into the CBV to enable a warmup under cold weather conditions or a prefilling of the system.

**Master model code**

**CBV model code breakdown**

General Product Description				Main Function				Special Function				Settings & Specials					
Series	Size	A	Z	B	C	D	E	F	G	H	J	K	L	M	N	P	R
CBV																	

**General product description**

*Size - Port diameter*

Code	Description
25A	DN25, nominal flow 300 l/min for H1B080 and/or H1B110
32A	DN32, nominal flow 400l/min for H1B160
32B	DN32, nominal flow 400l/min for H1B210 and/or H1B250

*A - Product version*

Code	Description
A	Revision Code

*Z - Threads*

Code	Description
M	All threaded ports with flat elastomer sealing metric ISO 9974-1

**Main function**

*B - Housing variant*

Code	Description
A	Standard - with all ports machined

*C - Spring cap orientation / stroke limitation*

Code	Description
B	Long Side on B

*D - Spool design*

Code	Description
A20	200l/min piston in idle position closed
A30	300l/min piston in idle position closed
A40	400l/min piston in idle position closed
Y20	200l/min piston in idle position open, remaining opening 2.0 mm
Z15	150l/min piston in idle position open, remaining opening 2.3 mm
Z30	300l/min piston in idle position open, remaining opening 2.3 mm

**Master model code***E - Damping*

<b>Code</b>	<b>Description</b>
A0	Harsh/very intensive braking behavior (very short closing duration) - 0.6mm
A1	Keen/intensive braking behavior (short closing duration) - 0.5 mm
A2	Mean/medium braking behavior (medium closing duration) - 0.3mm
A3	Weak/soft braking behavior (long closing duration) - 0.25mm

**Master model code**
**Special function**
*F - double check valve*

Code	Description
NN	Both standard

*G - brake release*

Code	Description
L	Reduced high pressure 21bar
S	System pressure

*H - flushing*

Code	Description
T	Max. 7l/min flushing (orifice 1.1mm) – 8bar opening pressure

*J - suction*

Code	Description
S	Port S machined for prefilling

**Settings and special hardware**
*K - HPRV port A*

Code	Description
415	415 bar on Port A

*L - HPRV port B*

Code	Description
415	415 bar on Port B

*M - Stroke limitation*

Code	Description
NN	No Stroke Limitation

*N - Idle*

Code	Description
NN	None

*Special hardware*

Code	Description
NN	None

**Master model code**

*R - Paint and nametag*

<b>Code</b>	<b>Description</b>
NNN	Black paint & Danfoss Nametag

## **Master model code**

### **CBV ordering information**

When requesting a quote or placing an order, the following information is necessary to ensure the correct function and system model generation:

- CBV model code and correlating bent axis motor
- Pump flow
- Application

A system optimization for the first prototype with regard to the valve block, motor and counterbalance valve is absolutely necessary.



**CBV installation**

In the system product the CBV is mounted at the H1B-motor with axial port endcap without loop flushing valve hardware. The motor model code must contain special endcap "TC" for 2-position motor and "PE" option for proportional motors. These options are endcaps without loop flushing functionality and special mounting threads to keep the valve in place.

The components are mounted together with two tacking screws, which have a need torque of  $10 \pm 1$  N-m M6x90-8.8. Do not remove the tacking screws when connecting the service lines.

The final arrangement of the motor system to the machine is by the connection of the main pressure line, e.g. using SAE 4-bolt flanges. 6 screws have a minimum depth of 90mm, the thread depth in the motor is 23mm (total 113mm). The blind hole has depth of 19.5 mm. See drawing below:

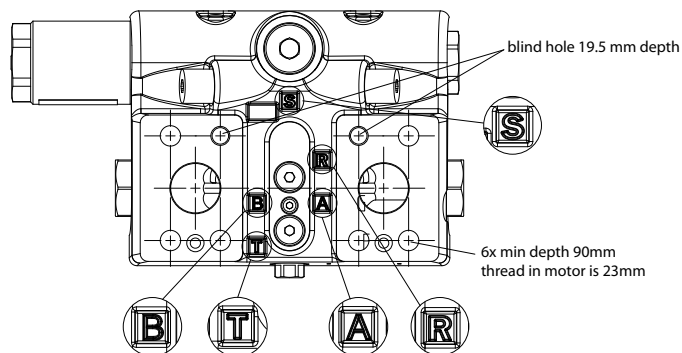

## Safety information

### CBV safety guidelines

Failure to observe any of the following points may lead to uncontrolled working conditions with serious personal injury and material damage.

 **Caution**

---

All types of directional spool valves can fail and cause serious damage. Analyze all aspects of the applications.

The machine builder / system integrator alone is responsible for making the final selection of the products and assuring that all performance, safety and warning requirements of the application are met.

The process of choosing the control system and safety levels is governed by Machinery Directive 2006-42-EC and harmonized standard EN13849.

---

- CBV is designed to be used in open circuit applications to enable smooth braking. CBV does not replace mechanical park brake. Appropriate brake system required. CBV only enables a smooth driving behavior.
- Project planning, assembly and commissioning of the motor with counterbalance valve require the involvement of qualified personnel.
- Prototyping and testing is required for proper system function and performance.
- CBV and main control valve must match to one another. The system must be free of air for proper function.
- If the CBV utilizes a brake release option, maximum park brake pressure and pressure from the CBV must match. Otherwise, the system can be damaged. There is high pressure option and reduced pressure for brake release function.
- As a CBV converts kinetic energy into heat, sufficient cooling and/or tank capacity must be available. During and shortly after operation, the temperature at the motor will be elevated. Take suitable safety measures (e.g. wear protective clothing) to protect from the risk of burns.
- Suction pressure port at port S reduces the risk of cavitation due to lack of fluid in the low-pressure line. Ensure sufficient flow and pressure.
- There may be shifts in the characteristic depending on the operating state of the axial piston unit (operating pressure, fluid temperature).
- The data and note contained herein must be adhered to.

### Recommended safety standards

All documented safety measures must be considered and adopted to the application. If necessary, safety measures may be extended.

The following standards are recommended:

- ISO 4413: 2010 Hydraulic fluid power: general rules and safety requirements for systems and their components (former times EN DIN 982).
- ISO 13849-2: 2003 Safety of machinery: safety-related parts of control systems - Part 2 Table C1 + C2.
- Machinery-Directive 2006/42/EC of the European Parliament and of the Council of 17 May 2006 on machinery, and amending Directive 95/16/EC.

CBV dimensions

Dimensions are shown in mm.

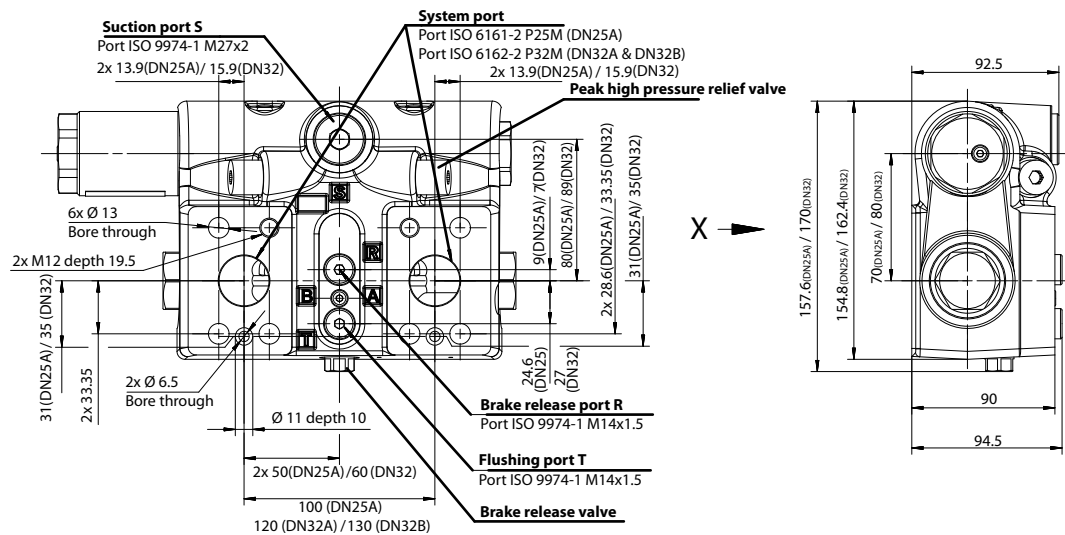

Further configurations as well as system outlines in conjunction with motors can be requested from your Danfoss Representative.

**Products we offer:**

- Cartridge valves
- DCV directional control valves
- Electric converters
- Electric machines
- Electric motors
- Gear motors
- Gear pumps
- Hydraulic integrated circuits (HICs)
- Hydrostatic motors
- Hydrostatic pumps
- Orbital motors
- PLUS+1® controllers
- PLUS+1® displays
- PLUS+1® joysticks and pedals
- PLUS+1® operator interfaces
- PLUS+1® sensors
- PLUS+1® software
- PLUS+1® software services, support and training
- Position controls and sensors
- PVG proportional valves
- Steering components and systems
- Telematics

**Danfoss Power Solutions** is a global manufacturer and supplier of high-quality hydraulic and electric components. We specialize in providing state-of-the-art technology and solutions that excel in the harsh operating conditions of the mobile off-highway market as well as the marine sector. Building on our extensive applications expertise, we work closely with you to ensure exceptional performance for a broad range of applications. We help you and other customers around the world speed up system development, reduce costs and bring vehicles and vessels to market faster.

Danfoss Power Solutions – your strongest partner in mobile hydraulics and mobile electrification.

**Go to [www.danfoss.com](http://www.danfoss.com) for further product information.**

We offer you expert worldwide support for ensuring the best possible solutions for outstanding performance. And with an extensive network of Global Service Partners, we also provide you with comprehensive global service for all of our components.

Local address:

**Hydro-Gear**

[www.hydro-gear.com](http://www.hydro-gear.com)

**Daikin-Sauer-Danfoss**

[www.daikin-sauer-danfoss.com](http://www.daikin-sauer-danfoss.com)

**Danfoss  
Power Solutions (US) Company**  
2800 East 13th Street  
Ames, IA 50010, USA  
Phone: +1 515 239 6000

**Danfoss  
Power Solutions GmbH & Co. OHG**  
Krokamp 35  
D-24539 Neumünster, Germany  
Phone: +49 4321 871 0

**Danfoss  
Power Solutions ApS**  
Nordborgvej 81  
DK-6430 Nordborg, Denmark  
Phone: +45 7488 2222

**Danfoss  
Power Solutions Trading  
(Shanghai) Co., Ltd.**  
Building #22, No. 1000 Jin Hai Rd  
Jin Qiao, Pudong New District  
Shanghai, China 201206  
Phone: +86 21 2080 6201

Danfoss can accept no responsibility for possible errors in catalogues, brochures and other printed material. Danfoss reserves the right to alter its products without notice. This also applies to products already on order provided that such alterations can be made without subsequent changes being necessary in specifications already agreed. All trademarks in this material are property of the respective companies. Danfoss and the Danfoss logotype are trademarks of Danfoss A/S. All rights reserved.