

Technical Information

shhark[®]

Aluminum Group 2 Pump

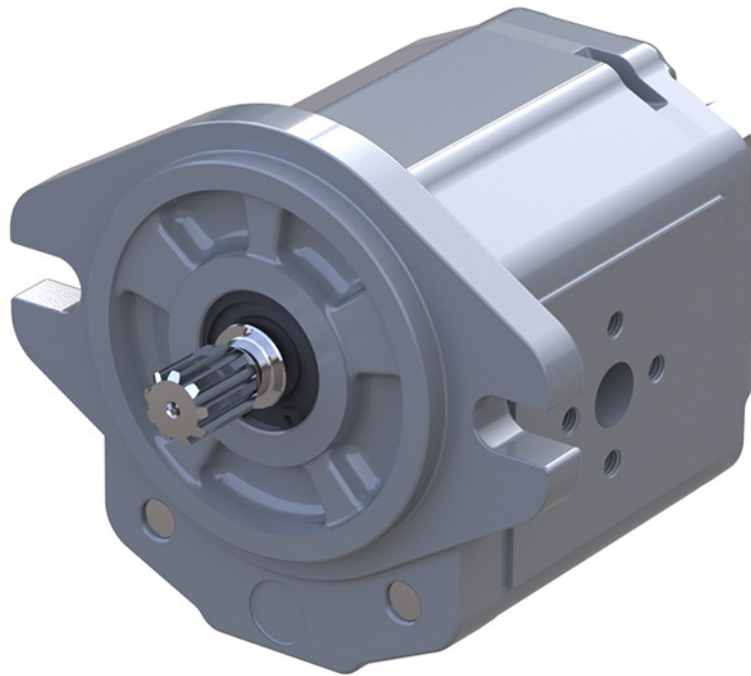

Revision history

Table of revisions

Date	Changed	Rev
May 2023	Content updates	0301
January 2023	Renamed product	0203
August 2022	Updated master model code for clarity	0202
July 2021	Sound level graphs added	0201
February 2020	Added frame size 025 sound levels graphs	0105
November 2019	Minor edits to text, tables and the diagrams in "Dimensions and Data"	0104
October 2019	Features text change on page 6.	0103
October 2019	New images replacement.	0102
September 2019	First edition.	0101

Contents

General information

The shhark® Low Noise Technology.....	4
Features and Benefits.....	5
shhark® Gear Pumps Representatives.....	5
Advantages of the shhark® technology versus the “dual contact flank” technology.....	6
shhark® Pump Design.....	6
shhark® Technical Data.....	7
Determination of Nominal Pump Sizes.....	8

Master Model Code

Model Code for Single Gear Pumps.....	11
Model Code for Tandem Gear Pumps.....	12
Model Code for Tandem Gear Pumps.....	14

System Requirements

Inlet Pressure.....	16
Speed.....	17
Hydraulic Fluids.....	17
Temperature and viscosity.....	17
Filtration.....	19
Filters.....	19
Selecting a filter.....	19
Reservoir.....	19
Line sizing.....	19
Pump Drive.....	20
Pump Life.....	20
Sound Level.....	21

Sound Level Graph

Pump Performance Graphs

Performance Graphs for Frame Size 8,0 and 011.....	23
Performance Graphs for Frame Size 014 and 017.....	23
Performance Graphs for Frame Size 019, 022 and 025.....	24

Product Options

Standard Flange, Shaft and Ports Configuration Overview.....	25
Shaft Options.....	26
Pumps with integral relief valve • internally and externally drained.....	27
Integral relief valve covers E10 or I10.....	28
Model Codes for Integral Relief Valve.....	29

Dimensions and Data

SHP2 with E10-T80 flange-drive gear combination.....	30
SHP2 with B10-T50 flange-drive gear combination.....	31
SHP2 with D10-I10 flange-drive gear combination.....	32
SHP2 with B20/B22 - T50 flange-drive gear combination.....	33
SHP2 with SA1 - S09/S11/PS1 flange-drive gear combination.....	34

General information

The shhark® Low Noise Technology

The standard technology currently used in low noise gear pumps is based on double-flank contact. This solution reduces the peak-to-peak flow pulsation by 75% compared to a single-flank contact gear pumps with the same number of teeth.

The Danfoss shhark® achieves the same reduction of flow pulsation, but in a totally different way. As illustrated below, for the same outer diameter, shhark® gears feature almost twice the number of teeth of a standard gear pump, thanks to a revolutionary asymmetric tooth profile design. Moreover, the shhark® teeth are also slightly helical; the small helix angle does not generate any additional radial and axial load but makes the flow characteristic smoother, further reducing the flow pulsation.

Standard gear pump (11-teeth) versus shhark® (17-teeth) technology



The comparison between the flow characteristic of Danfoss SKP2 (11-teeth) and shhark® (17-teeth) is illustrated in the plot below: the reduction of peak-to-peak flow pulsation is 78%. In addition, the average flow per unit width of shhark® is approximately 2.7% higher than SKP2; this means that for the exact same pump dimensions, shhark® delivers more flow.

Flow characteristics of shhark® vs SKP2 standard

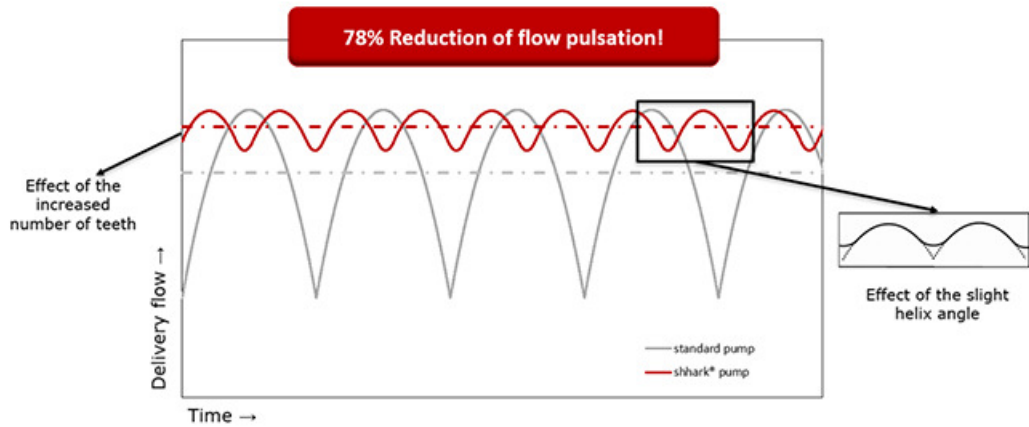

General information
Features and Benefits

- Noise level emissions reduced up to 10 dB(A)
- Low noise performance guaranteed throughout the whole life of the pump
- Low vibration, flow pulsation reduced by a stunning 78% compared to a standard gear pump
- Higher volumetric efficiency than a standard gear pump by 2%
- Noise emitted at low frequency, resulting in high sound quality
- Wide range of displacements from 6.2 to 28.9 cm³/rev
- Rated pressure up to 250 bar
- Operating speed up to 4000 rpm
- SAE, DIN and European standard mounting flanges and shafts
- Available with integral relief valve
- Interchangeable with all standard gear pumps
- Multiple pump configurations, available also in compact configuration
- Compact and lightweight
- Internal spline available, which means compactness and availability of big displacements working at high pressure simultaneously (maximum 120 Nm at the intermediate coupling)
- Helps to meet legal NVH requirements
- Innovative solution (Danfoss Patents US 20150330387 (A1) and WO2017064046 (A1))
- Ideal for hybrid and full electric machines for which the hydraulic pump is the most important source of noise together with fan drive
- Cost and space saving due to elimination of end-of-line noise reduction measures

shhark® Gear Pumps Representatives

Many combinations of the gear pumps are available as multiple units made to fit any need.



General information

Advantages of the shhark® technology versus the “dual contact flank” technology

The effectiveness of dual contact flank is very likely to decrease throughout the pump’s life, because external gear units often work at high pressure with high level of contaminants in the hydraulic fluid.

In such conditions, the critical components of the rotating kit slowly wear out, with a progressive loss of the double-flank contact condition and with it, the low noise performance.

shhark® pumps are able to keep low noise performance even after thousands of hours of heavy duty operation in the field and it even slightly improve, due to the tribologic adaptation of components, while in the same conditions the dual contact flank pump starts emitting noise due to gears wearing. In addition, shhark® emits noise at lower frequency than the dual contact flank technology, resulting in a better sound quality.

shhark® Pump Design

In terms of rated operating range (speed, pressure and temperature), overall dimensions and available configurations, the shhark® has been designed to be essentially a low noise version of SKP2 pump.

The 20 mm shaft can accommodate any type of drive end, such as:

- S09 (SAE 9-teeth 16/32)
- S11 (SAE 11-teeth 16/32)
- S13 (SAE 13-teeth 16/32)
- T50 (Taper 1:5)
- T80 (Taper 1:8)
- PS1 (Parallel SAE Ø15.875)
- I10 (Tang 8x17.8)

As for SKP2, the hydrostatic compensation system is on the bearing blocks to ensure high efficiency, more compact tandem combinations and higher flexibility to distributors.

SHP2 - SA1-S11 cutaway view

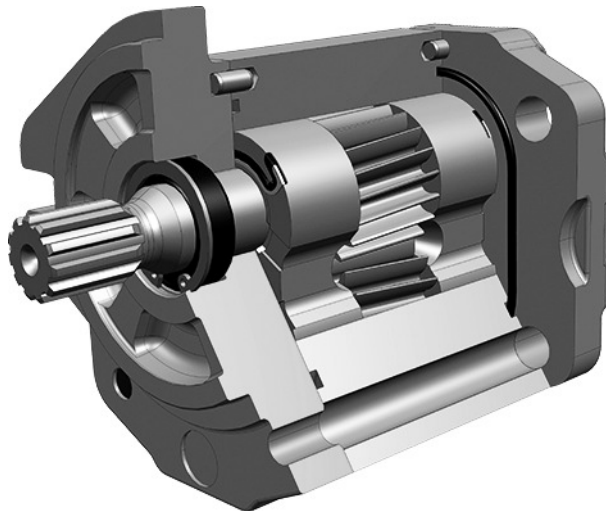

General information

shhark® Technical Data

The table below details the technical data for shhark® gear pumps based on the model and displacement configuration.

Technical data for SHP2

Feature	Unit	Frame size								
		6.0	8.0	011	014	017	019	022	025	028
Displacement	cm ³ /rev [in ³ /rev]	6.2 [0.37]	8.6 [0.53]	11.1 [0.68]	14.8 [0.90]	17.2 [1.06]	19.7 [1.21]	23.4 [1.43]	25.8 [1.58]	28.9 [1.75]
Peak pressure	bar [psi]	280 [4060]	280 [4060]	280 [4060]	280 [4060]	280 [4060]	260 [3770]	230 [3335]	200 [2900]	190 [2755]
Rated pressure		250 [3625]	250 [3625]	250 [3625]	250 [3625]	250 [3625]	240 [3480]	210 [3045]	190 [2755]	180 [2610]
Minimum speed at 0-100 bar	min ⁻¹ (rpm)	600	600	500	500	500	500	500	500	500
Minimum speed at 100-180 bar	min ⁻¹ (rpm)	1200	1000	800	750	750	700	700	700	600
Minimum speed at 180 bar to rated pressure	min ⁻¹ (rpm)	1400	1400	1200	1000	1000	1000	800	800	700
Maximum speed		4000	4000	4000	3500	3000	3000	3000	3000	2500
Weight	kg [lb]	2.4 [5.3]	2.5 [5.5]	2.7 [5.5]	2.9 [6.3]	3.0 [6.5]	3.1 [6.7]	3.2 [7.0]	3.4 [7.5]	3.4 [7.5]
Moment of inertia of rotating components	x 10 ⁻⁶ kg·m ² [⁻⁶ lb·ft ²]	27.6 [629]	32.4 [769]	38.4 [911]	47.3 [1122]	53.3 [1265]	59.2 [1405]	68.1 [1616]	71.1 [1687]	77.6 [1827]
Theoretical flow at maximum speed	l/min [US gal/min]	24.72 [6.4]	34.8 [9.2]	44.4 [11.7]	51.8 [13.7]	51.9 [13.7]	59.4 [15.7]	70.5 [18.6]	77.8 [20.6]	72.5 [19.1]

$$1 \text{ kg}\cdot\text{m}^2 = 23.68 \text{ lb}\cdot\text{ft}^2$$

Caution

The rated and peak pressure mentioned in the table are for pumps with flanged ports only. When threaded ports are required a de-rated performance has to be considered. To verify the compliance of a high pressure application with a threaded ports pump apply to a Danfoss representative.

General information

Determination of Nominal Pump Sizes

Generally, the sizing process is initiated by an evaluation of the machine system to perform the necessary work function. The following formulae can be used to determine the nominal pump size for a specific application.

	Metric System	Inch System
Output flow	$Q_e = \frac{V_g \cdot n \cdot \eta_v}{1000}$ (l/min)	$Q_e = \frac{V_g \cdot n \cdot \eta_v}{231}$ (US gal/min)
Input torque	$M_e = \frac{V_g \cdot \Delta p}{20 \cdot \pi \cdot \eta_m}$ (N·m)	$M_e = \frac{V_g \cdot \Delta p}{2 \cdot \pi \cdot \eta_m}$ (lbf·in)
Input power	$P_e = \frac{M_e \cdot n \cdot \pi}{30\,000} = \frac{Q_e \cdot \Delta p}{600 \cdot \eta_t}$ (kW)	$P_e = \frac{M_e \cdot n \cdot \pi}{198\,000} = \frac{Q_e \cdot \Delta p}{1714 \cdot \eta_t}$ (hp)

Variables:

V_g = Displacement per rev.
p_{HP} = High pressure
p_{NP} = Low pressure
Δp = p_{HP} - p_{NP}
n = Input speed
η_v = Volumetric efficiency
η_m = Mechanical (torque) efficiency
η_t = Overall efficiency (η_v · η_m)

SI units [US units]:

cm³/rev [in³/rev]
 bar [psi]
 bar [psi]
 bar [psi]
 min⁻¹ (rpm)

Master Model Code

Model Code for Single Gear Pumps

A	B	C	D	E	F	G	H	I	J	K	L	M	N	O
SHP2											

A – Family

SHP2	Low-noise Group 2 gear pump
-------------	-----------------------------

B – Frame size and Displacement

6,0	6.2 cm ³ *
8,0	8.6 cm ³
011	11.1 cm ³
014	14.8 cm ³
017	17.2 cm ³
019	19.7 cm ³
022	23.4 cm ³
025	25.8 cm ³

* Frame size 028 is available upon a request.

C – Direction of Rotation

L	Left hand (Counter-clockwise)
R	Right hand (Clockwise)

D – Mounting flange

B10	Pilot Ø80 mm; 4 holes
B20	Pilot Ø50 mm; 2 holes through body
B21	Pilot Ø50 mm; 2 holes through body; Seal on pilot
B22	Pilot Ø50 mm; 2 holes through body
D10	Pilot Ø52 mm; O-ring; 4 holes through body
E10	Pilot Ø36.5 mm; 4 holes
SA1	SAE A pilot Ø82.55 mm; 2 holes
SA2	SAE A pilot Ø82.55 mm; 2 holes; Seal on pilot
SB1	SAE B pilot Ø101.6 mm; 2 holes

Master Model Code

Model Code for Single Gear Pumps

A	B	C	D	E	F	G	H	I	J	K	L	M	N	O
SHP2										

E – Shaft type

T50	Taper 1:5; M12x1.25 with Key 3
T80	Taper 1:8; M12x1.25 with Key 4
I10	Tang 8 x Ø17.8 x 6.5
PS1	Parallel SAE Ø15.875 x 23.8; Key 4x18
S09	Spline SAE J498-9T-16/32DP
S11	Spline SAE J498-11T-16/32DP
S13	Spline SAE J498-13T-16/32DP

F – Inlet and G – Outlet ports dimensions

Code	Dimensions	Ports	Code	Thread Dimensions
B5	15x35xM6		D5	M18x1.5
B6	15x40xM6		D7	M22x1.5
B7	20x40xM6		E4	3/4-16UNF
C3	13.5x30xM6		E5	7/8-14UNF
C5	13.5x40xM8		E6	1 ¹ / ₁₆ -12UN
C7	20x40xM8		F3	3/8 Gas
MB	12 x 38.1 x 17.48 x M8 (=)		F4	1/2 Gas
MC	18.5 x 47.63 x 22.23 x M6 (=)		F5	3/4 Gas
MD	18.5 x 47.63 x 22.23 x M8 (=)		F6	1 Gas
ME	18.5 x 47.63 x 22.23 x M10 (=)		H5	M18 x 1.5 per ISO6149
MG	25/20 x 52.37 x 26.19 x M10 (=)		H7	M22 x 1.5 per ISO6149
NN	Without outlet port <u>To be used with rear ported units only.</u>		H8	M27 x 2 per ISO6149
		H9	M33 x 2 per ISO6149	

H - Rear cover

P10	Standard cover for pump
I10	Rear cover for pump with relief valve with internal drain
E10	Rear cover for pump with relief valve with external drain 3/8 Gas

Master Model Code

Model Code for Single Gear Pumps

A	B	C	D	E	F	G	H	I	J	K	L	M	N	O
SHP2							

I – Shaft seal

V	Viton
----------	-------

J – Sealing

N	NBR
----------	-----

K – Screws

N	Standard burnished screws
A	Zinc plated screws
B	Geomet screws

L – Valve setting

NNN	No valve
V**	Integral relief valve pressure setting

M – Marking type

N	Standard Danfoss marking
A	Danfoss marking + Customer code
Z	No marking

N – Mark position

S	Sticker marking on body
----------	-------------------------

O – Special features

0000	No special features
-------------	---------------------

Master Model Code

Model Code for Tandem Gear Pumps

A1	B1	A2	B2	C	D	E	F1	G1	H	F2	G2	I	J	K	L	M	N	O	P
.															

A1 – First stage family and A2 - Second stage family

SHP2	Low-noise Group 2 gear pumps
SKP2	Standard Group 2 gear pump

B1 – Pump 1st frame size and B2 – Pump 2nd frame size displacement

6,0	6.2 cm ³ *
8,0	8.6 cm ³
011	11.1 cm ³
014	14.8 cm ³
017	17.2 cm ³
019	19.7 cm ³
022	23.4 cm ³
025	25.8 cm ³ **

* Frame size 028 is available upon a request.

** Frame size 025 is available for **B1** only.

C – Direction of Rotation

L	Left hand (Counter-clockwise)
R	Right hand (Clockwise)

Master Model Code

Model Code for Tandem Gear Pumps

A1	B1	A2	B2	C	D	E	F1	G1	H	F2	G2	I	J	K	L	M	N	O	P	
					.	.														

D – Mounting flange

B10	Pilot Ø80 mm; 4 holes
B20	Pilot Ø50 mm; 2 holes through body
B21	Pilot Ø50 mm; 2 holes through body; Seal on pilot
B22	Pilot Ø50 mm; 2 holes through body
E10	Pilot Ø36.5 mm; 4 holes
SA1	SAE A pilot Ø82.55 mm; 2 holes
SA2	SAE A pilot Ø82.55 mm; 2 holes; Seal on pilot
SB1	SAE B pilot Ø101.6 mm; 2 holes

E – Shaft type

T50	Taper 1:5; M12x1.25 with Key 3
T80	Taper 1:8; M12x1.25 with Key 4
S09	Spline SAE J498-9T-16/32DP
S11	Spline SAE J498-11T-16/32DP
S13	Spline SAE J498-13T-16/32DP

Master Model Code

Model Code for Tandem Gear Pumps

A1	B1	A2	B2	C	D	E	F1	G1	H	F2	G2	I	J	K	L	M	N	O	P	
														

F – Inlet and G – Outlet ports dimensions

Code	Dimensions	Ports	Code	Thread Dimensions	
B5	15x35xM6		D5	M18x1.5	
B6	15x40xM6		D7	M22x1.5	
B7	20x40xM6		E4	3/4-16UNF	
C3	13.5x30xM6		E5	7/8-14UNF	
C5	13.5x40xM8		E6	1 ¹ / ₁₆ -12UN	
C7	20x40xM8		F3	3/8 Gas	
MB	12 x 38.1 x 17.48 x M8 (=)		F4	1/2 Gas	
MC	18.5 x 47.63 x 22.23 x M6 (=)		F5	3/4 Gas	
MD	18.5 x 47.63 x 22.23 x M8 (=)		F6	1 Gas	
ME	18.5 x 47.63 x 22.23 x M10 (=)		H5	M18 x 1.5 per ISO6149	
MG	25/20 x 52.37 x 26.19 x M10 (=)		H7	M22 x 1.5 per ISO6149	
NN	Without outlet port To be used with rear ported units only.		H8	M27 x 2 per ISO6149	
		H9	M33 x 2 per ISO6149		

H – Intermediate section

CC	Standard compact intermediate flange
-----------	--------------------------------------

I – Cover

E10	Rear cover for pump with relief valve with external drain 3/8 Gas
I10	Rear cover for pump with relief valve with internal drain
P10	Standard cover for pump

Master Model Code

Model Code for Tandem Gear Pumps

A1	B1	A2	B2	C	D	E	F1	G1	H	F2	G2	I	J	K	L	M	N	O	P
												

J – Shaft seal

V	Viton
----------	-------

K – Sealing

N	NBR
----------	-----

L – Screws

N	Standard burnished screws
A	Zinc plated screws
B	Geomet screws

M – Valve setting

NNN	No valve
V**	Integral relief valve pressure setting

N – Marking type

N	Standard Danfoss marking
A	Standard Danfoss marking + Customer code
Z	No marking

O – Mark position

S	Sticker marking on body
----------	-------------------------

P – Special features

0000	No special features
-------------	---------------------

System Requirements

Inlet Pressure

Peak pressure is the highest intermittent pressure allowed at the pump's outlet. Peak pressure depends on the relief valve over shoot (reaction time).

Rated pressure is the maximum continuous operating pressure. The maximum machine load demand determines rated pressure.

Inlet Vacuum must be controlled in order to preserve pump's expected life and performance.

The system design must meet inlet pressure requirements during all operation modes. Expected lower inlet pressures during cold start will be improved as soon as the fluid warms up.

Max. continuous vacuum	Max. intermittent vacuum	Max. inlet pressure
0.8 bar absolute [20.7in. Hg]	0.6 bar absolute [17.7in. Hg]	4.0 bar absolute [118.1in. Hg]

The illustration below shows peak pressure in relation to rated pressure and reaction time (100 ms maximum).

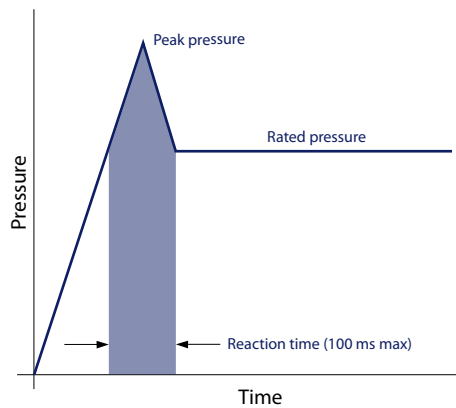

System Requirements

Speed

Maximum speed is the limit recommended by Danfoss for a particular gear pump when operating at rated pressure. It is the highest speed at which normal life can be expected.

Minimum speed is the lowest operating speed limit at which normal life can be expected. The minimum speed increases according to operating pressure increase.

When operating at higher pressures, a higher minimum speed must be maintained, see below:

Speed versus pressure

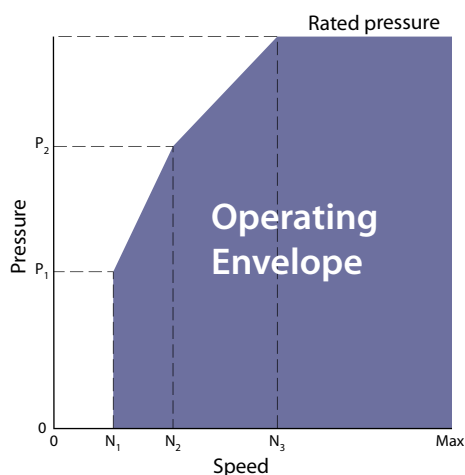

Operating envelope legend:

- N₁** Minimum speed at 100 bar
- N₂** Minimum speed at 180 bar
- N₃** Minimum speed at rated pressure

Hydraulic Fluids

Pressure ratings in this document are determined using petroleum-based hydraulic fluids. Ratings and data are guaranteed when the hydraulic system operates with premium hydraulic fluids without containing oxidation, rust, or foam inhibitors.

These fluids have to work with good thermal and hydrolytic stability to prevent wear, erosion, or corrosion of internal components.

These fluids include:

- Hydraulic fluids following DIN 51524, part 2 (HLP) and part 3 (HVLP) specifications
- API CD engine oils conforming to SAE J183
- M2C33F or G automatic transmission fluids
- Certain agricultural tractor fluids

Avoid using fluids with a mixture of two different oils. These fluids may damage the product and decrease lubrication efficiency. For use with other oils, contact your Danfoss representative for approval.

Mixing hydraulic fluids or using contaminated fluids may damage the interior of the product.
 Do not mix hydraulic fluids. Use only clean hydraulic fluid.

Temperature and viscosity

Temperature and viscosity requirements must be concurrently satisfied. Use petroleum / mineral-based fluids.

High temperature limits apply at the inlet port to the pump. The pump should run at or below the maximum continuous temperature. The peak temperature is based on material properties. Don't exceed it.

Cold oil, generally, doesn't affect the durability of pump components. It may affect the ability of oil to flow and transmit power. For this reason, keep the temperature at 16 °C [60 °F] above the pour point of the hydraulic fluid.

System Requirements

Minimum (cold start) temperature relates to the physical properties of component materials.

Minimum viscosity occurs only during brief occasions of maximum ambient temperature and severe duty cycle operation. You will encounter maximum viscosity only at cold start. During this condition, limit speeds until the system warms up. Size heat exchangers to keep the fluid within these limits. Test regularly to verify that these temperatures and viscosity limits aren't exceeded. For maximum unit efficiency and bearing life, keep the fluid viscosity in the recommended

Fluid viscosity

Maximum (cold start)	mm ² /s [SUS]	1600 [7273]
Recommended range		12-100 [66-456]
Minimum		10 [60]

Temperature (with standard NBR seals)

Minimum (cold start)	°C [°F]	-20 [-4]
Maximum continuous		80 [176]
Peak (intermittent)		90 [194]

System Requirements

Filtration

Filters

Use a filter that conforms to Class 20/18/13 of ISO 4406 (or better). It may be on the motor outlet (discharge filtration) or inlet (pressure filtration).

Selecting a filter

When selecting a filter, please consider:

- Contaminant ingress rate (determined by factors such as the number of actuators used in the system)
- Generation of contaminants in the system
- Required fluid cleanliness
- Desired maintenance interval
- Filtration requirements of other system components

Measure filter efficiency with a Beta ratio (β_x). β_x ratio is a measure of filter efficiency defined by ISO 4572. It is the ratio of the number of particles greater than a given diameter (in microns) upstream of the filter to the number of these particles downstream of the filter.

- For discharge filtration with controlled reservoir ingress rate, use a $\beta_{35-45} = 75$ filter
- For pressure filtration, use a filtration with an efficiency of $\beta_{10} = 75$

The filtration requirements for each system are unique. Evaluate filtration system capacity by monitoring and testing prototypes.

Fluid cleanliness level and β_x ratio

Fluid cleanliness level (per ISO 4406)	Class 20/18/13 or better
β_x ratio (discharge filtration)	$\beta_{35-45} = 75$ and $\beta_{10} = 2$
β_x ratio (pressure or return filtration)	$\beta_{10} = 75$
Recommended inlet screen size	100 – 125 μm [0.004 – 0.005 in]

Reservoir

The **reservoir** provides clean fluid, dissipates heat, removes entrained air, and allows fluid volume changes associated with fluid expansion and cylinder differential volumes. A correctly sized reservoir accommodates maximum volume changes during all system operating modes. It promotes de-aeration of the fluid as it passes through, and accommodates a fluid dwell-time between 60 and 180 seconds, allowing entrained air to escape.

Minimum reservoir capacity depends on the volume required to cool and hold the oil from all retracted cylinders, allowing for expansion due to temperature changes. A fluid volume of 1 to 3 times the pump output flow (per minute) is satisfactory. The minimum reservoir capacity is 125% of the fluid volume.

Install the suction line above the bottom of the reservoir to take advantage of gravity separation and prevent large foreign particles from entering the line. Cover the line with a 100-125 micron screen. The pump should be below the lowest expected fluid level.

Put the return-line below the lowest expected fluid level to allow discharge into the reservoir for maximum dwell and efficient deaeration. A baffle (or baffles) between the return and suction lines promotes deaeration and reduces fluid surges.

Line sizing

Choose pipe sizes that accommodate minimum fluid velocity to reduce system noise, pressure drops, and overheating. This maximizes system life and performance.

Design inlet piping that maintains continuous pump inlet pressure above 0.8 bar absolute during normal operation. The line velocity should not exceed the values in this table:

System Requirements

Maximum line velocity

Inlet	m/s [ft/sec]	2.5 [8.2]
Outlet		5.0 [16.4]
Return		3.0 [9.8]

Most systems use hydraulic oil containing 10% dissolved air by volume. Under high inlet vacuum conditions the oil releases bubbles. They collapse when subjected to pressure, resulting in cavitation, causing adjacent metal surfaces to erode. **Over-aeration** is the result of air leaks on the inlet side of the pump, and flow-line restrictions. These include inadequate pipe sizes, sharp bends, or elbow fittings, causing a reduction of flow line cross sectional area. This problem will not occur if inlet vacuum and rated speed requirements are maintained, and reservoir size and location are adequate.

Pump Drive

Shaft options for shhark® Group 2 gear pump include tapered, tang, splined, or parallel shafts. They are suitable for a wide range of direct and indirect drive applications for radial and thrust loads.

Plug-in drives, acceptable only with a splined shaft, can impose severe radial loads when the mating spline is rigidly supported. Increasing spline clearance does not alleviate this condition. Use plug-in drives if the concentricity between the mating spline and pilot diameter is within 0.1 mm [0.004 in]. Lubricate the drive by flooding it with oil. A 3-piece coupling minimizes radial or thrust shaft loads.

Pilot cavity

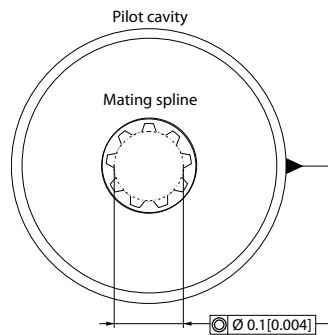

⚠ Caution

In order to avoid spline shaft damages it is recommended to use carburized and hardened steel couplings with 80-82 HRA surface hardness.

Allowable **radial shaft loads** are a function of the load position, load orientation, and operating pressure of the hydraulic pump. All external shaft loads have an effect on bearing life, and may affect pump performance.

In applications where external shaft loads can't be avoided, minimize the impact on the pump by optimizing the orientation and magnitude of the load. Use a tapered input shaft; don't use splined shafts for belt or gear drive applications. A spring-loaded belt tension-device is recommended for belt drive applications to avoid excessive tension. Avoid thrust loads in either direction. Contact Danfoss if continuously applied external radial or thrust loads occur.

Pump Life

Pump life is a function of speed, system pressure, and other system parameters (such as fluid quality and cleanliness).

All Danfoss gear pumps use hydrodynamic journal bearings that have an oil film maintained between the gear/shaft and bearing surfaces at all times. If the oil film is sufficiently sustained through proper system maintenance and operating within recommended limits, long life can be expected.

System Requirements

B_{10} life expectancy number is generally associated with rolling element bearings. It does not exist for hydrodynamic bearings.

High pressure, resulting from high loads, impacts pump life. When submitting an application for review, provide machine duty cycle data that includes percentages of time at various loads and speeds. We strongly recommend a prototype testing program to verify operating parameters and their impact on life expectancy before finalizing any system design.

Sound Level

Fluid power systems are inherent generators of noise. As with many high power density devices, noise is an unwanted side effect.

However, there are many techniques available to minimize noise associated with fluid power systems. To apply these methods effectively, it is necessary to understand how the noise is generated and how it reaches the listener. The noise energy can be transmitted away from its source as either fluid borne noise (pressure ripple) or as structure borne noise.

Fluid borne noise (pressure ripple) is the result of the number of pumping elements (gear teeth) delivering oil to the outlet and the pump's ability to gradually change the volume of each pumping element from high to low pressure. In addition, the pressure ripple is affected by the compressibility of the oil as each pumping element discharges into the outlet of the pump. Pressure pulsations will travel along the hydraulic lines at the speed of sound (about 1400 m/s in oil) until affected by a change in the system such as an elbow fitting. Thus the pressure pulsation amplitude varies with overall line length and position.

Structure borne noise may be transmitted wherever the pump casing is connected to the rest of the system. The response of one circuit component to excitation depends on its size, form, and manner in which it is mounted or supported. Because of this excitation, a system line may actually have a greater noise level than the pump. To reduce this excitation, use flexible hoses in place of steel plumbing. If steel plumbing must be used, clamping of lines is recommended. To minimize other structure borne noise, use flexible (rubber) mounts.

[Contact your Danfoss representative for assistance with system noise control.](#)

Sound Level Graph

The sound level graph below shows comparative sound pressure levels for shhark® and standard pumps (with SAE A flange and spline shaft) expressed in dB(A) at 1 m [3.28 ft] from the unit.

Data were taken using ISO VG46 petroleum /mineral based fluid at 50°C (viscosity at 28 mm²/s [cSt]).

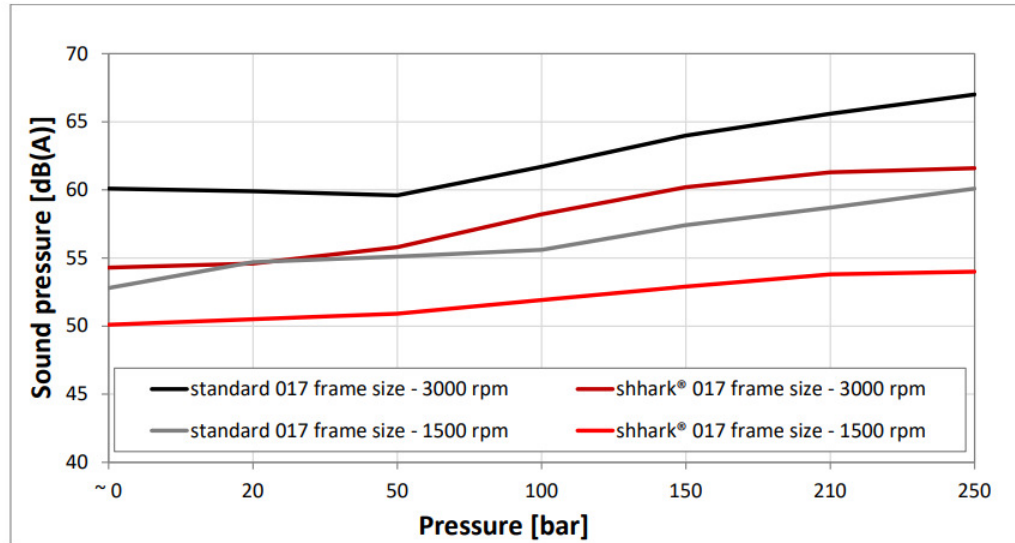

For more details about shhark® noise performance contact your Danfoss Sales Representative.

Pump Performance Graphs

The graphs on the next pages provide typical output flow and input power for shhark® pumps at various working pressures.

Data were taken using ISO VG46 petroleum /mineral based fluid at 50°C (viscosity at 28 mm²/s [cSt]).

Performance Graphs for Frame Size 8,0 and 011

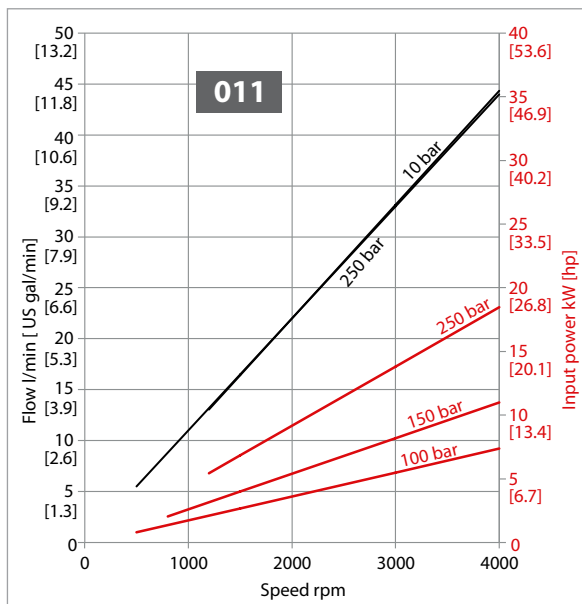
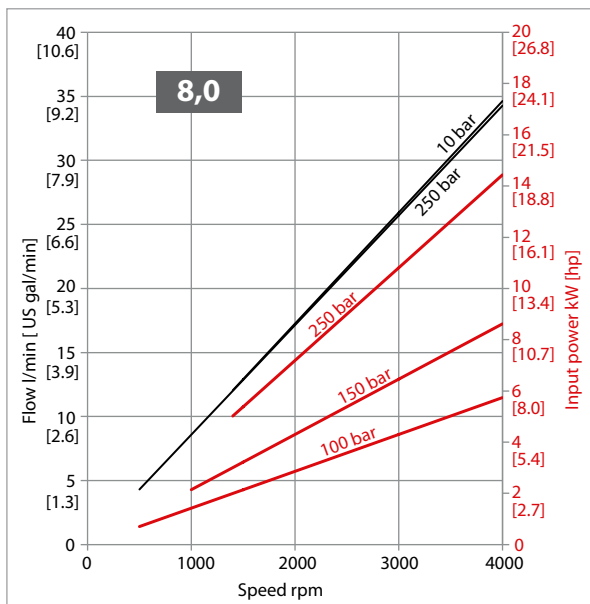

Performance Graphs for Frame Size 014 and 017

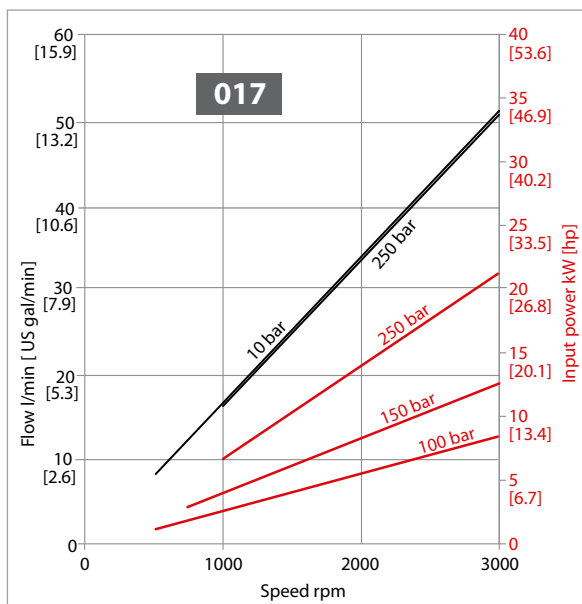
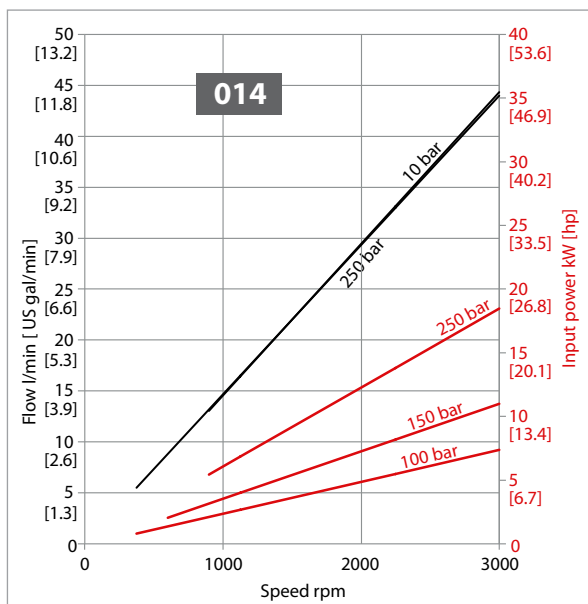

Pump Performance Graphs

Performance Graphs for Frame Size 019, 022 and 025

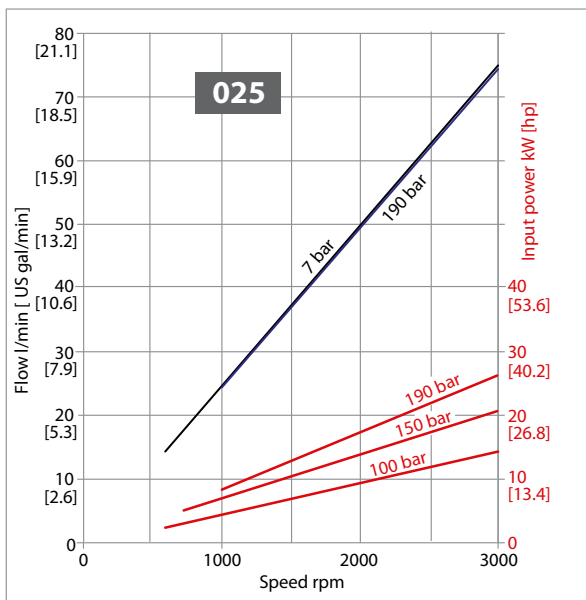
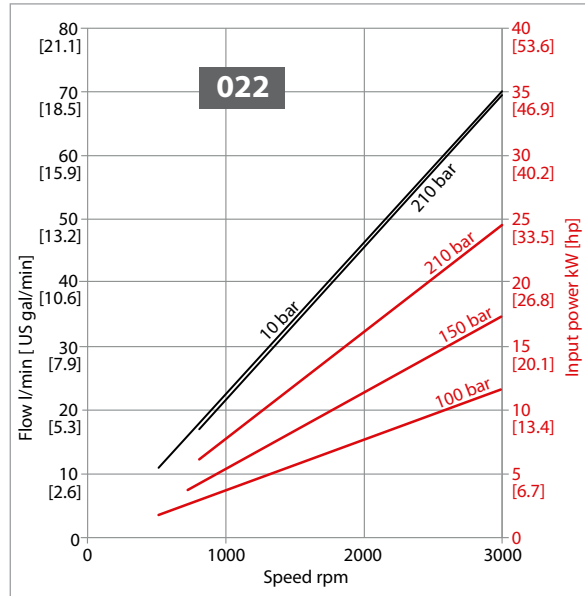
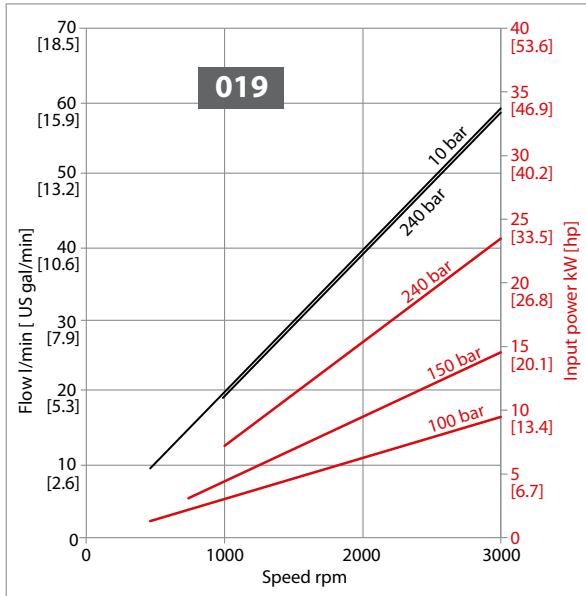

Product Options

Standard Flange, Shaft and Ports Configuration Overview

Code (single)	Flange	Shaft	Ports
E10-T80	Pilot Ø36.5 mm; 4 holes 	Taper 1:8; M12x1.25 with Key 4 	European 01, + pattern
B10-T50	Pilot Ø80 mm; 4 holes German PTO 	Taper 1:5; M12x1.25 with Key 3 	German standard, x pattern
D10-I10	Danfoss D10 	Danfoss tang 	German standard, x pattern
B20-T50	Pilot Ø50 mm; 2 holes through body German PTO 	Taper 1:5; M12x1.25 with Key 3 	German standard, x pattern
B22-T50	Pilot Ø50 mm; 2 holes through body German PTO 	Taper 1:5; M12x1.25 with Key 3 	German standard, x pattern
SA1-PS1	SAE A pilot Ø82.55 mm; 2 holes 	Ø15.875 mm [0.625 in] parallel SAE 	Threaded SAE; O-Ring boss
SA1-S09	SAE A pilot Ø82.55 mm; 2 holes 	Spline SAE J498-9T-16/32DP 	Threaded SAE; O-Ring boss
SA1-S11	SAE A pilot Ø82.55 mm; 2 holes 	Spline SAE J498-11T-16/32DP 	Threaded SAE; O-Ring boss
SB1-S13	SAE B 2 bolts pilot Ø101,6 	Spline SAE J498 - 13 T 	Threaded SAE; O-Ring boss

Other combinations are available upon request.

Product Options
Shaft Options

Direction is viewed facing the shaft. Group 2 pumps are available with a variety of tang, splined, parallel, and tapered shaft ends. Not all shaft styles are available with all flange styles.

Model code section H

A	B	C	D	E	F	G	H	I	J	K	L	M	N	O
							.							

Shaft versus flange availability and torque capability

Shaft		Mounting flange code with maximum torque in N·m [lbf·in]					
Description	Code	E10	B10	D10	B20	B22	SA1
Taper 1:5; M12x1.25 with Key 3	T50	–	140 [1239]	–	140 [1239]	140 [1239]	–
Taper 1:8; M12x1.25 with Key 4	T80	150 [1328]	–	–	–	–	–
Spline SAE J498-9T-16/32DP	S09	–	–	–	–	–	90 [796]
Spline SAE J498-11T-16/32DP	S11	–	–	–	–	–	150 [1328]
Parallel SAE Ø15.875 (5/8")	PS1	–	–	–	–	–	80 [708]
Parallel SAE Ø19.05 (¾")	PS2	–	–	–	–	–	150 [1328]

Other shaft options may exist. Contact your Danfoss representative for availability.

! Caution

Shaft torque capability may limit allowable pressure. Torque ratings assume no external radial loading. Applied torque must not exceed these limits, regardless of stated pressure parameters. Maximum torque ratings are based on shaft torsional fatigue strength.

The second section torque limit is equal to 120 N·m. Other configuration with higher rated torque are available upon request.

Product Options

Pumps with integral relief valve • internally and externally drained

Group 2 pumps are offered with an optional **integral relief valve** in the rear cover. This valve can have an internal (I10 cover option) or external drain (E10 cover option).

This valve opens directing all flow from the pump outlet to the internal or external drain when the pressure at the outlet reaches the valve setting. This valve can be ordered preset to the pressures shown in the table below. Valve performance curve, rear cover cross-section and schematics are shown below.

Integral relief valve performance graph

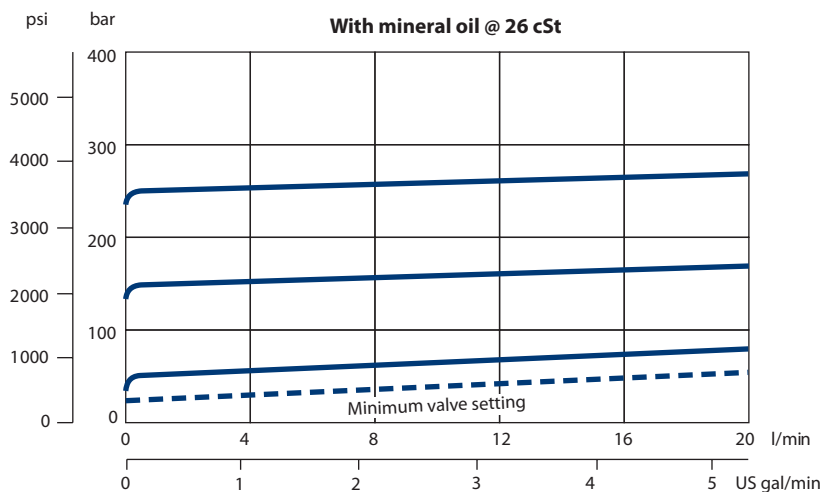

Integral relief valve cross-section

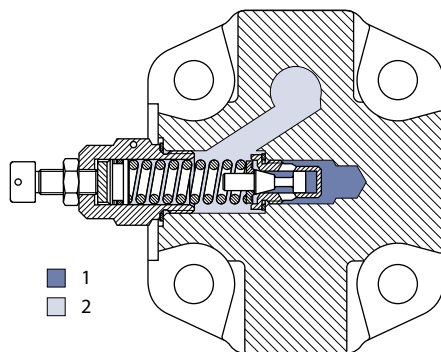

1. Inlet
2. Drain

⚠ Caution

When the relief valve is operating in bypass condition, rapid heat generation occurs. If this bypass condition continues, the pump prematurely fails. The reason for this is that it is a rule, not an exception. When frequent operation is required, external drain option must be used.

Product Options

Integral relief valve schematics

Integral relief valve with drain: internal (left) / external (right)

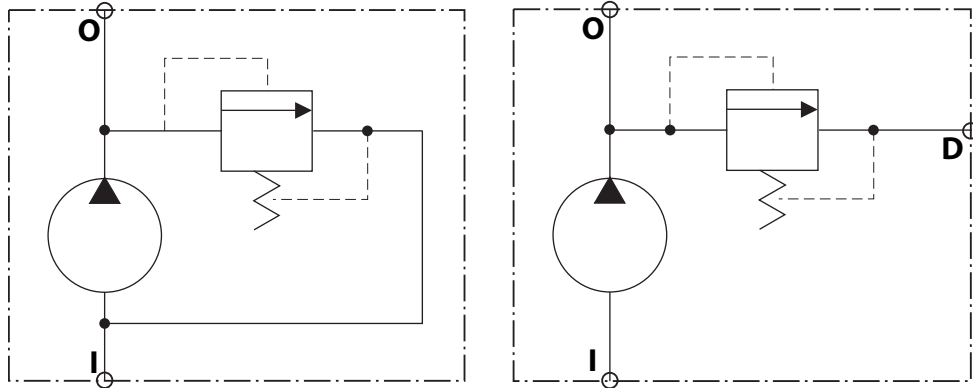

I – inlet
 O – outlet
 D – external drain

Integral relief valve covers E10 or I10

Dimensions (with SAE flange); mm [in]

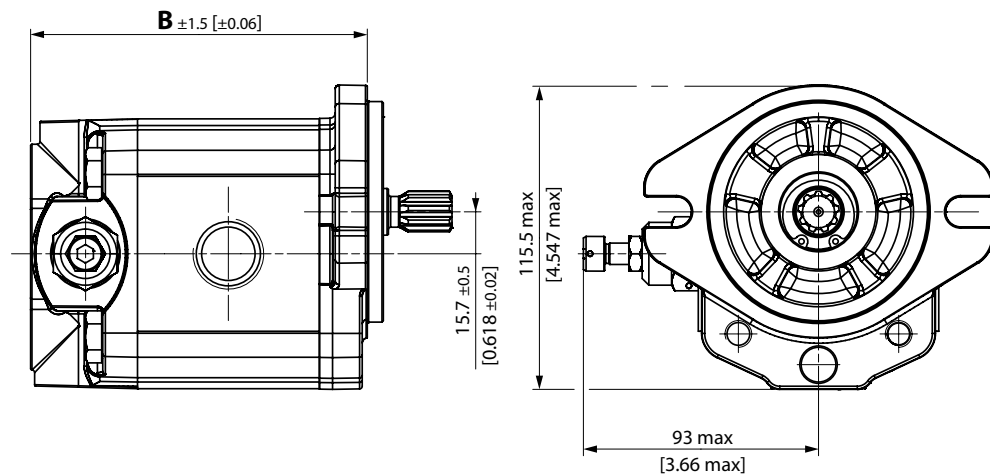

SHP2 with E10 or I10 cover dimensions

Frame size	8,0	011	014	017	019	022
B	117.5 [4.63]	121.5 [4.78]	127.5 [5.02]	131.5 [5.18]	135.5 [5.33]	141.5 [5.57]

Product Options

Model Codes for Integral Relief Valve

The tables below detail the various codes for ordering integral relief valves in M section of the model code:

A	B	C	D	E	F	G	H	I	J	K	L	M	N	O
SHP2							I10 •				VGN •			
SHP2	-017	-R	-SA1	-S11	-B7	-B5	-P10	-V	-N	-B	-V00	-N	-N	0000

N1 – integral relief valves variant codes

V	With integral relief valve variant
----------	------------------------------------

N2 – Pump speed codes

Code	Pump speed for RV setting	Code	Pump speed for RV setting
A	Not defined		
C	500 min ⁻¹ (rpm)	I	2250 min ⁻¹ (rpm)
E	1000 min ⁻¹ (rpm)	L	2500 min ⁻¹ (rpm)
F	1250 min ⁻¹ (rpm)	M	2800 min ⁻¹ (rpm)
G	1500 min ⁻¹ (rpm)	N	3000 min ⁻¹ (rpm)
K	2000 min ⁻¹ (rpm)	O	3250 min ⁻¹ (rpm)

N3 – Pressure setting codes

Code	Pressure setting	Code	Pressure setting
A	No setting		
B	No valve	P	100 bar [1450 psi]
C	18 bar [261 psi]	Q	110 bar [1595 psi]
D	25 bar [363 psi]	R	120 bar [1740 psi]
E	30 bar [435 psi]	S	130 bar [1885 psi]
F	35 bar [508 psi]	T	140 bar [2030 psi]
G	40 bar [580 psi]	U	160 bar [2320 psi]
K	50 bar [725 psi]	V	170 bar [2465 psi]
L	60 bar [870 psi]	W	180 bar [2611 psi]
M	70 bar [1015 psi]	X	210 bar [3046 psi]
N	80 bar [1160 psi]	Y	240 bar [3480 psi]
O	90 bar [1305 psi]	Z	250 bar [3626 psi]

Caution

For pressures higher than 210 bar or lower than 40 bar apply to your Danfoss representative.

Dimensions and Data

SHP2 with E10-T80 flange-drive gear combination

Standard porting for E10-T80; mm [in]

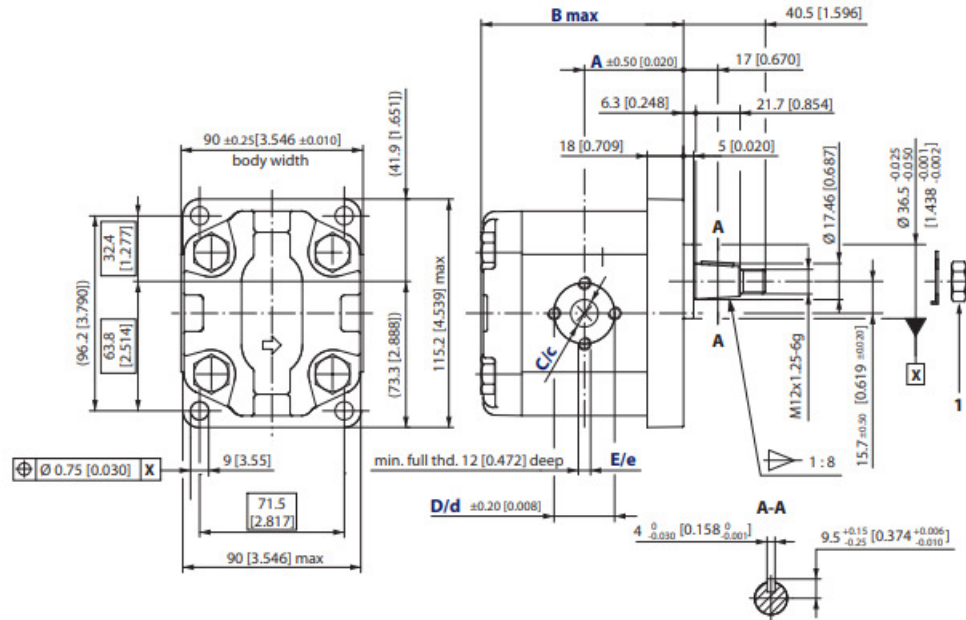

1. Nut and washer supplied with pump; recommended tightening torque 45-55 N·m.

SHP2 - E10-T80 dimensions

Frame size	6,0	8,0	011	014	017	019	022	025
Dimension	A	45 [1.772]	45 [1.772]	49 [1.929]	52 [2.047]	52 [2.047]	56 [2.205]	59 [2.323]
	B	93 [3.681]	97.5 [3.839]	101.5 [3.996]	107.5 [4.232]	111.5 [4.390]	115.5 [4.574]	121.5 [4.783]
Inlet	C	13.5 [0.531]			20 [0.787]			
	D	30 [1.181]			40 [1.575]			
	E	M6			M8			
Outlet	c	13.5 [0.531]						
	d	30 [1.181]						
	e	M6						

Model code example, maximum shaft torque

Flange/drive gear	Model code example	Maximum shaft torque
E10-T80	SHP2-014-R-E10-T80-C7-C3-P10-V-N-N-N00-N-N-0000	150 N·m [1328 lbf·in]

For further details on ordering, see the Model Code section.

Dimensions and Data

SHP2 with B10-T50 flange-drive gear combination

Standard porting for B10-T50; mm [in]

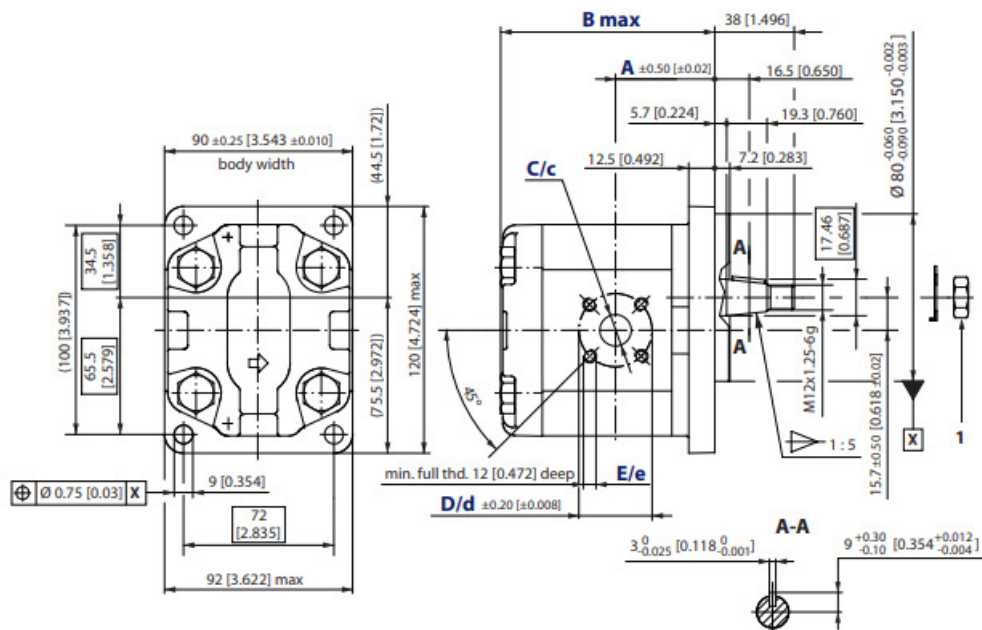

1. Nut and washer supplied with pump; recommended tightening torque 45-55 N•m.

SHP2 - B10-T50 dimensions

Frame size		6,0	8,0	011	014	017	019	022	025
Dimension	A	41.1 [1.618]	43.1 [1.697]	47.5 [1.870]	47.5 [1.870]	47.5 [1.870]	47.5 [1.870]	55 [2.165]	94.5 [2.539]
	B	96 [3.780]	100 [3.937]	104 [4.094]	110 [4.331]	114 [4.488]	118 [4.646]	124 [4.882]	128 [5.039]
Inlet	C	20 [0.787]							
	D	40 [1.575]							
	E	M6							
Outlet	c	15 [0.591]							
	d	35 [1.378]							
	e	M6							

Model code example, maximum shaft torque

Flange/drive gear	Model code example	Maximum shaft torque
B10-T50	SHP2-8,0-L-B10-T50-B7-B5-P10-V-N-N-N00-N-N-0000	140 N•m [1239 lbf•in]

For further details on ordering, see the Model Code section.

Dimensions and Data

SHP2 with D10-I10 flange-drive gear combination

Standard porting for D10-I10; mm [in]

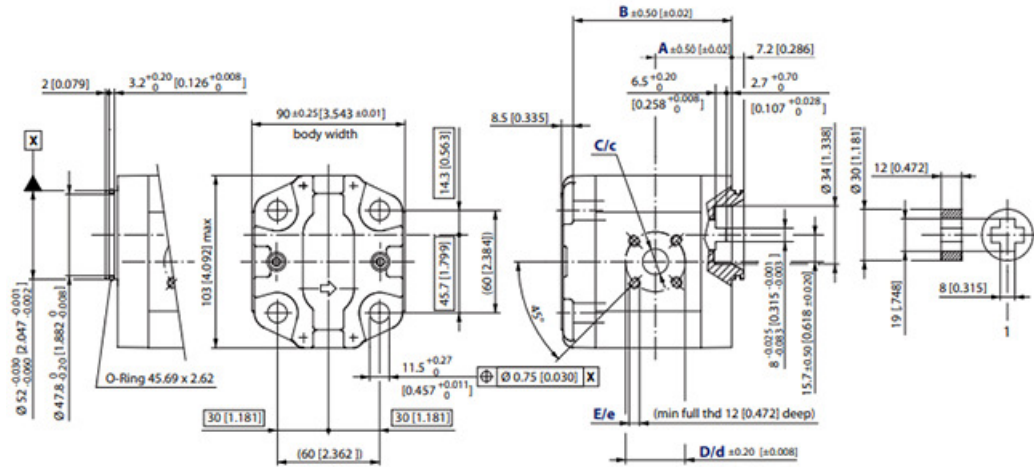

1. Coupling supplied with pump

1. Coupling supplied with pump

SHP2 - D10-I10 dimensions

Frame size	6,0	8,0	011	014	017	019	022	025
Dimension	A	38.6 [1.520]	40.6 [1.598]	45 [1.772]			52.5 [2.067]	62 [2.441]
	B	85 [3.364]	89 [3.503]	93 [3.661]	99 [3.897]	103 [4.055]	107 [4.212]	113 [4.448]
Inlet	C	20 [0.787]						
	D	40 [1.575]						
	E	M6						
Outlet	c	15 [0.591]						
	d	35 [1.378]						
	e	M6						

Model code example, maximum shaft torque

Flange/drive gear	Model code example	Maximum shaft torque
D10-I10	SHP2-017-R-D10-I10-B7-B5-P10-V-N-N-N00-N-N-0000	70 N·m [620 lbf·in]

For further details on ordering, see the Model Code section.

Dimensions and Data

SHP2 with B20/B22 - T50 flange-drive gear combination

Standard porting for B20/B22-T50; mm [in]

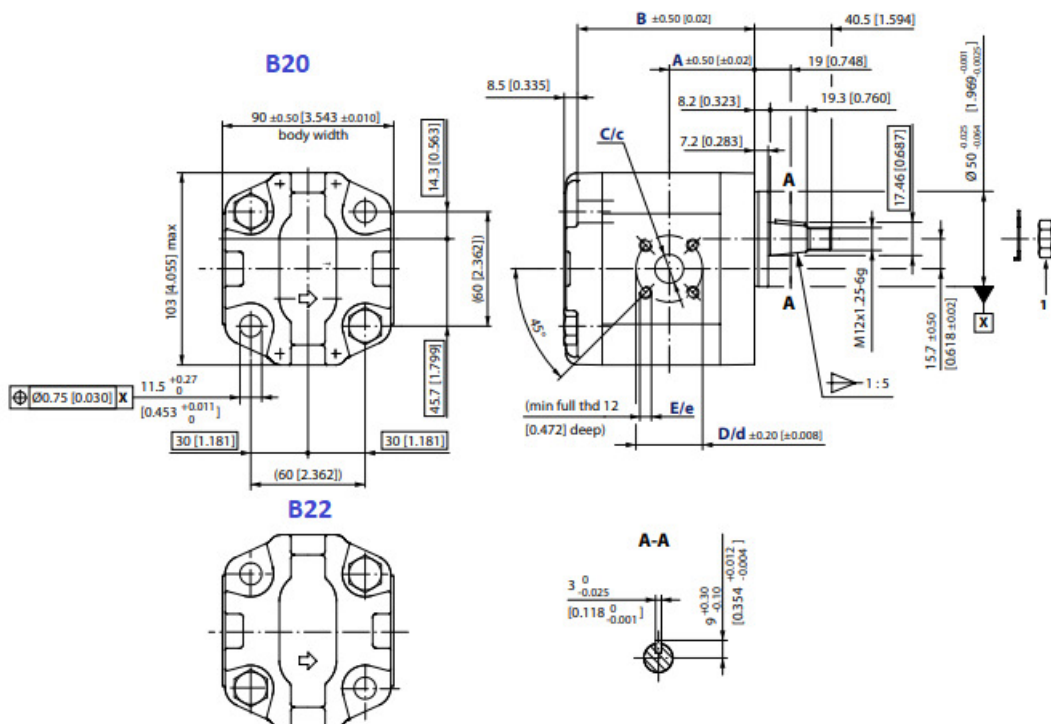

1. Nut and washer supplied with pump; recommended tightening torque 45-55 N•m.

SHP2 – B20/B22-T50 dimensions

Frame size	6,0	8,0	011	014	017	019	022	025
Dimension	A	38.6 [1.520]	40.6 [1.598]	45 [1.772]			52.5 [2.067]	62 [2.441]
	B	85 [3.364]	89 [3.503]	93 [3.661]	99 [3.897]	103 [4.055]	107 [4.212]	113 [4.448]
Inlet	C	20 [0.787]						
	D	40 [1.575]						
	E	M6						
Outlet	c	15 [0.591]						
	d	35 [1.378]						
	e	M6						

Model code example, maximum shaft torque

Flange/drive gear	Model code example	Maximum shaft torque
B20-T50	SHP2-8,0-L-B20-T50-B7-B5-P10-N-N-N-N00-N-N-0000	140 N•m [1239 lbf•in]
B22-T50	SHP2-014-R-B22-T50-B7-B5-P10-N-N-N-N00-N-N-0000	

For further details on ordering, see the Model Code section.

Dimensions and Data

SHP2 with SA1 - S09/S11/PS1 flange-drive gear combination

Standard porting for SA1 - S09/S11/PS1; mm [in]

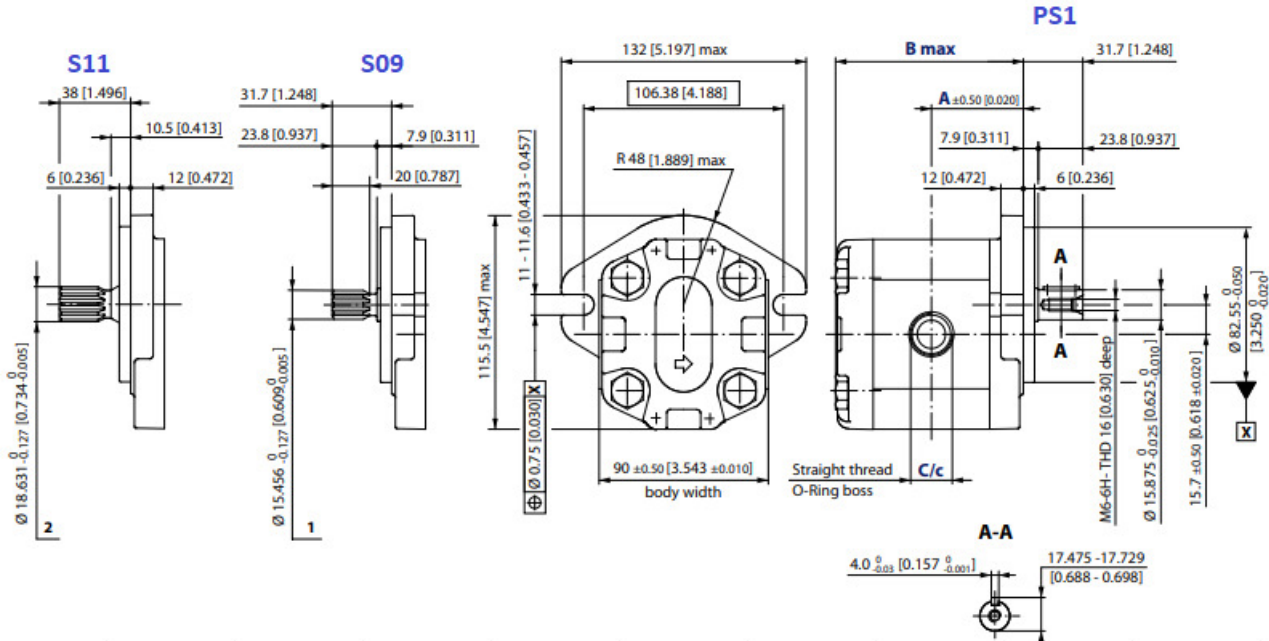

1. Splined: SAE J498-9T-16/32DP; Flat root side fit (circular tooth thickness 0.127 mm [0.005] less than standard class 1 fit)
2. Splined: SAE J498-11T-16/32DP; Flat root side fit (circular tooth thickness 0.127 mm [0.005] less than standard class 1 fit)

SHP2 – SA1 - S09/S11/PS1 dimensions

Frame size	6,0	8,0	011	014	017	019	022	025	
Dimension	A	45 [1.772]	47 [1.85]	49 [1.92]	52 [2.047]	54 [2.126]	56 [2.205]	59 [2.323]	61 [2.402]
	B	93.5 [3.681]	97.5 [3.839]	101.5 [3.996]	107.5 [4.232]	111.5 [4.390]	115.5 [4.547]	121.5 [4.783]	125.5 [4.941]
Inlet	C	1 ¹ / ₁₆ -12UNF-2B, 18.0 [0.709] deep							
Outlet	c	7 ¹ / ₈ -14UNF-2B, 16.7 [0.658] deep							

Model code examples, maximum shaft torques

Flange/drive gear	Model code example	Maximum shaft torque
SA1-PS1	SHP2-6,0-R-SA1-PS1-E6-E5-P10-N-N-N-N00-N-N-0000	80 N·m [708 lbf·in]
SA1-S09	SHP2-011-L-SA1-S09-E6-E5-P10-N-N-N-N00-N-N-0000	90 N·m [796 lbf·in]
SA1-S11	SHP2-022-R-SA1-S11-E6-E5-P10-N-N-N-N00-N-N-0000	150 N·m [1328 lbf·in]

For further details on ordering, see the Model Code section.

Products we offer:

- Cartridge valves
- DCV directional control valves
- Electric converters
- Electric machines
- Electric motors
- Gear motors
- Gear pumps
- Hydraulic integrated circuits (HICs)
- Hydrostatic motors
- Hydrostatic pumps
- Orbital motors
- PLUS+1® controllers
- PLUS+1® displays
- PLUS+1® joysticks and pedals
- PLUS+1® operator interfaces
- PLUS+1® sensors
- PLUS+1® software
- PLUS+1® software services, support and training
- Position controls and sensors
- PVG proportional valves
- Steering components and systems
- Telematics

Danfoss Power Solutions is a global manufacturer and supplier of high-quality hydraulic and electric components. We specialize in providing state-of-the-art technology and solutions that excel in the harsh operating conditions of the mobile off-highway market as well as the marine sector. Building on our extensive applications expertise, we work closely with you to ensure exceptional performance for a broad range of applications. We help you and other customers around the world speed up system development, reduce costs and bring vehicles and vessels to market faster.

Danfoss Power Solutions – your strongest partner in mobile hydraulics and mobile electrification.

Go to www.danfoss.com for further product information.

We offer you expert worldwide support for ensuring the best possible solutions for outstanding performance. And with an extensive network of Global Service Partners, we also provide you with comprehensive global service for all of our components.

Local address:

Hydro-Gear

www.hydro-gear.com

Daikin-Sauer-Danfoss

www.daikin-sauer-danfoss.com

**Danfoss
Power Solutions (US) Company**
2800 East 13th Street
Ames, IA 50010, USA
Phone: +1 515 239 6000

**Danfoss
Power Solutions GmbH & Co. OHG**
Krokamp 35
D-24539 Neumünster, Germany
Phone: +49 4321 871 0

**Danfoss
Power Solutions ApS**
Nordborgvej 81
DK-6430 Nordborg, Denmark
Phone: +45 7488 2222

**Danfoss
Power Solutions Trading
(Shanghai) Co., Ltd.**
Building #22, No. 1000 Jin Hai Rd
Jin Qiao, Pudong New District
Shanghai, China 201206
Phone: +86 21 2080 6201

Danfoss can accept no responsibility for possible errors in catalogues, brochures and other printed material. Danfoss reserves the right to alter its products without notice. This also applies to products already on order provided that such alterations can be made without subsequent changes being necessary in specifications already agreed. All trademarks in this material are property of the respective companies. Danfoss and the Danfoss logotype are trademarks of Danfoss A/S. All rights reserved.