

Service Manual

# PVG 16 and 32 Assembly/Disassembly Guide

PVG 16, PVG 32

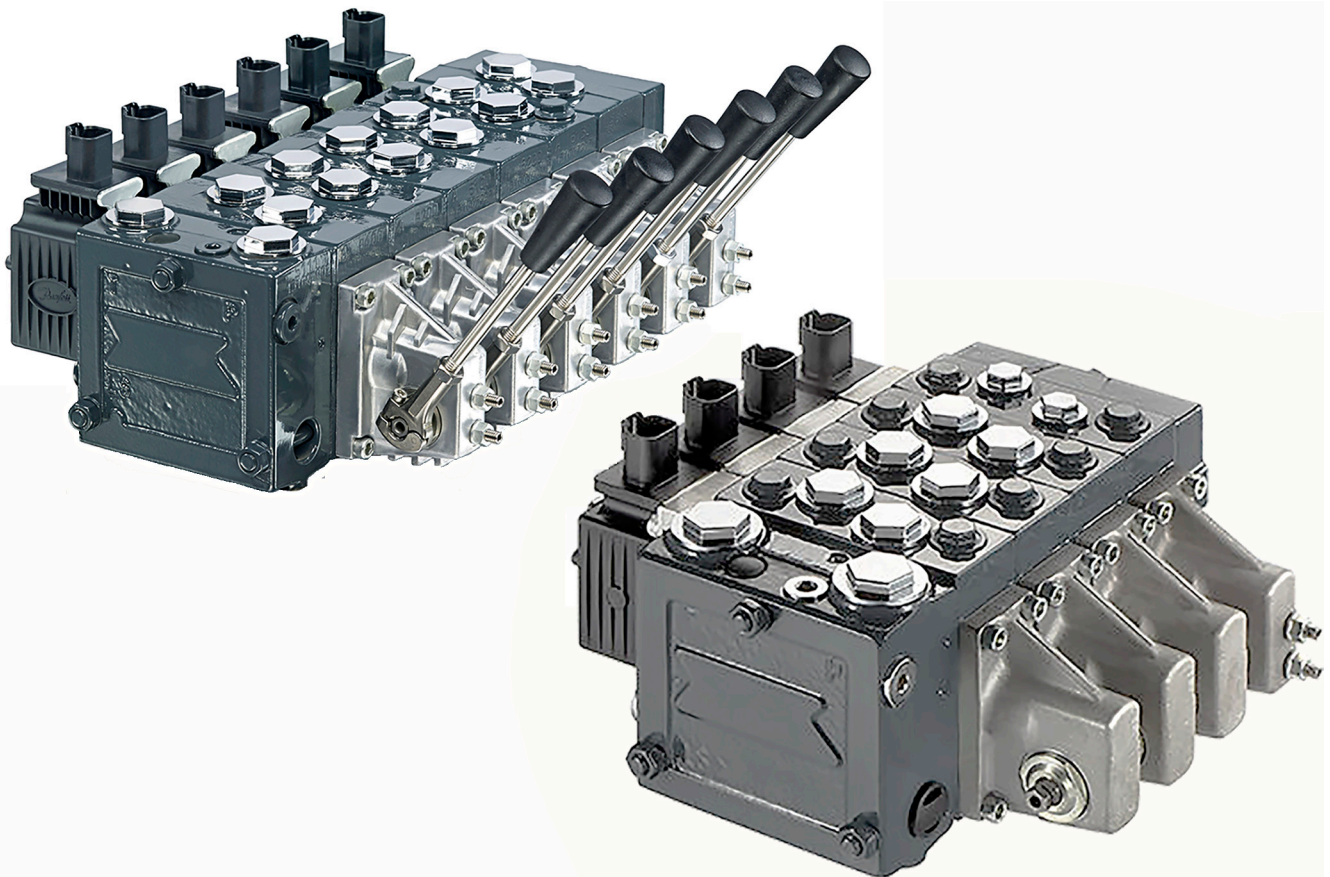

**Revision history***Table of revisions*

<b>Date</b>	<b>Changed</b>	<b>Rev</b>
June 2023	Changed document number from 'AX00000133' and 'L1104530' to 'AX152886482982' and updated text for clarification	0210
August 2018	Corrected typo on page 20	0107
November 2017	Minor text change	0106
February 2017	Uodated with PVE Series 7	0105
May 2014	Testing section added, cover image	AD
Apr 2014	Converted to Danfoss layout – DITA CMS	AC
Aug 2013	Torgue change in dwg, page 19	AB
Jun 2012	First Edition	AA

**Contents**

**General information**

PVG general description..... 4

Features of PVG 16 and PVG 32..... 4

PVG modules ..... 5

    PVP, pump side modules overview..... 5

    PVB, basic modules..... 5

    Actuation modules..... 5

PVG 16, PVG 32 and Open Circuit Load Sense Example..... 6

Load sensing controls..... 7

    LS control with bleed orifice (do not use with PVG valves)..... 7

    Integral PC function..... 7

    Load sensing system characteristics:..... 7

PVBS, main spools with pressure compensated control..... 8

    Pressure compensated system characteristics..... 8

    Typical applications for pressure compensated systems..... 9

Remote pressure compensated controls..... 10

    Remote pressure compensated system characteristics:..... 10

    Typical applications for remote pressure compensated systems:..... 10

Open center PVP..... 11

Closed center PVP..... 11

**Sectional view**

**Safety in Application**

Example of a control system for manlift..... 13

    Examples of wiring block diagram..... 15

**Assembly instructions**

PVG 16 and 32 general conditions..... 17

Assembly..... 17

**Testing**

PVG 16 and 32 leak test..... 22

Pressure setting after assembly..... 22

PVG 16 and 32 function testing..... 23

    Recommended equipment and hand tools to assemble PVG 16 and PVG 32:..... 24

**Test report**

**Order specifications**

## General information

### PVG general description

PVG is a hydraulic, load-sensing proportional valve, designed for optimal machine performance and maximum design flexibility.

The PVG valve design is based on a modular concept that enables machine designers to specify a valve solution suitable for multiple market segments across multiple applications.

The load independent proportional control valve and high performance actuator technology combined with a low pressure drop design improves the machine performance and efficiency – increasing productivity and reducing energy consumption.

### Features of PVG 16 and PVG 32

- Load-independent flow control:
  - Oil flow to an individual function is independent of the load pressure of this function
  - Oil flow to one function is independent of the load pressure of other functions
- Good regulation characteristics
- Energy-saving
- Up to 12 basic modules per valve group
- Several types of connection threads
- Low weight
- Compact design and installation

*PVG 32 and PVG 16*



## General information

### PVG modules

#### **PVP, pump side modules overview**

- Built-in pressure relief valve
- Pressure gauge connection
- Versions:
  - Open center version for systems with fixed displacement pumps
  - Closed center version for systems with variable displacement pumps
  - Pilot oil supply for electrical actuator built into the pump side module
  - Pilot oil supply for hydraulic actuation built into the pump side module
  - Versions prepared for electrical LS unloading valve PVPX

#### **PVB, basic modules**

- Interchangeable spools
- Depending on requirements the basic module can be supplied with:
  - Integrated pressure compensator in channel P
  - Load holding check valve in channel P
  - Shock/suction valves for A and B ports
  - LS pressure limiting valves individually adjustable for ports A and B
  - Different interchangeable spool variants
  - All versions suitable for mechanical, hydraulic and electrical actuation

#### **Actuation modules**

The basic module is always fitted with mechanical actuator PVM and PVMD, which can be combined with the following as required:

- Electrical actuator (11 - 32 V ===):
  - PVES – proportional, Super
  - PVEH – proportional, High performance
  - PVEH-F – proportional high performance, Float
  - PVEA – proportional low hysteresis
  - PVEM – proportional, Medium performance
  - PVEO – ON/OFF
  - PVEH-U/PVES-U – proportional, voltage control, 0-10 V
  - PVED-CC – Digital CAN controlled J1939/ISOBUS
  - PVED-CX – Digital CAN controlled CANopen X-tra safety
  - PVEP – PWM voltage controlled (11-32 V)
  - PVHC – High Current actuator for PVG
- PVMR, cover for Mechanical detent
- PVMF, cover for Mechanical Float
- PVH, cover for Hydraulic actuation

**General information**

**PVG 16, PVG 32 and Open Circuit Load Sense Example**

The pump receives fluid directly from the reservoir through the inlet line. A screen in the inlet line protects the pump from large contaminants. The pump outlet feeds directional control valves such as PVG-32's, hydraulic integrated circuits (HIC), and other types of control valves. The PVG valve directs and controls pump flow to cylinders, motors and other work functions. A heat exchanger cools the fluid returning from the valve. A filter cleans the fluid before it returns to the reservoir.

Flow in the circuit determines the speed of the actuators. The position of the PVG valve spool determines the flow demand. A hydraulic pressure signal (LS signal) communicates demand to the pump control. The pump control monitors the pressure differential between pump outlet and the LS signal, and regulates servo pressure to control the swashplate angle. Swashplate angle determines pump flow.

Actuator load determines system pressure. The pump control monitors system pressure and will decrease the swashplate angle to reduce flow if system pressure reaches the PC setting. A secondary system relief valve in the PVG valve acts as a back-up to control system pressure.

*Pictorial circuit diagram*

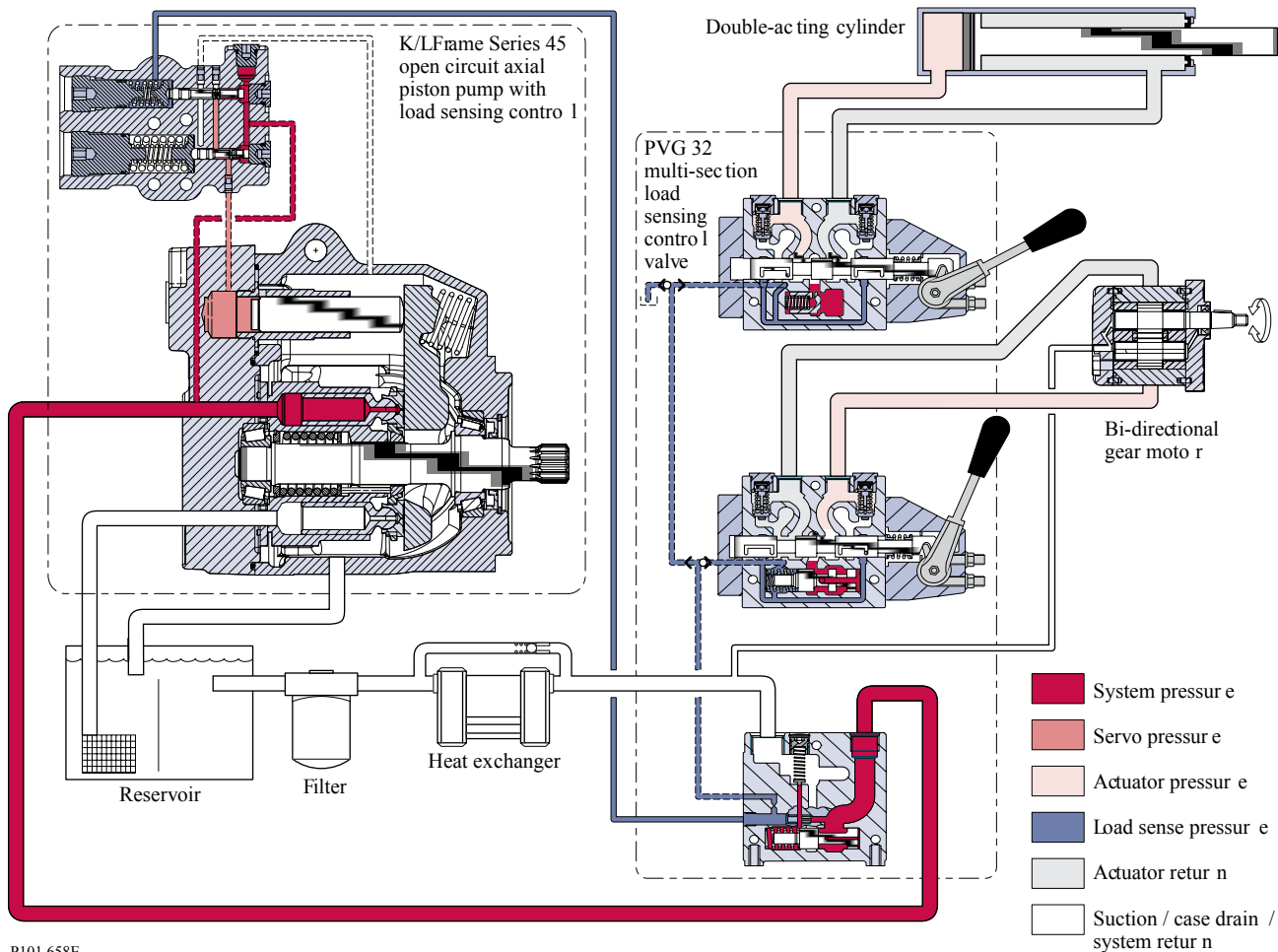

P101 658E

## General information

### Load sensing controls

The LS control matches system requirements for both pressure and flow in the circuit regardless of the working pressure. Used with a closed center control valve, the pump remains in low-pressure standby mode with zero flow until the valve is opened. The LS setting determines standby pressure.

Typical operating curve

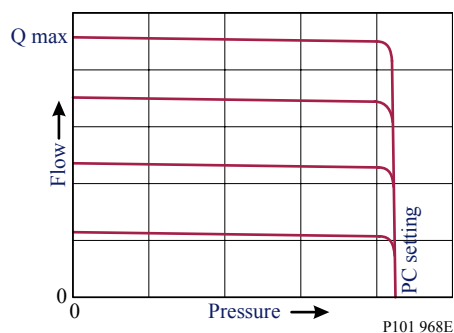

Load sensing circuit

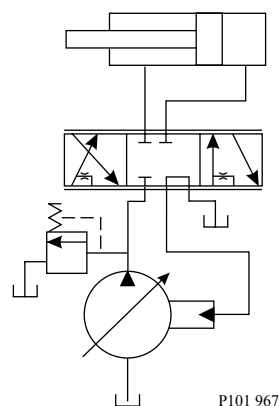

Most load sensing systems use parallel, closed center, control valves with special porting that allows the highest work function pressure (LS signal) to feed back to the LS control.

*Margin pressure* is the difference between system pressure and the LS signal pressure. The LS control monitors margin pressure to read system demand. A drop in margin pressure means the system needs more flow. A rise in margin pressure tells the LS control to decrease flow.

#### LS control with bleed orifice (do not use with PVG valves)

The load sense signal line requires a bleed orifice to prevent high-pressure lockup of the pump control. Most load-sensing control valves include this orifice. An optional internal bleed orifice is available, for use with control valves that do not internally bleed the LS signal to tank.

#### Integral PC function

The LS control also performs as a PC control, decreasing pump flow when system pressure reaches the PC setting. The pressure compensating function has priority over the load sensing function.

#### **Warning**

**A relief valve is required to be installed in the pump outlet for additional system protection. Failure to install a relief valve may lead to system damage and/or injury.**

#### Load sensing system characteristics:

- Variable pressure and flow
- Low pressure standby mode when flow is not needed
- System flow adjusted to meet system requirements
- Lower torque requirements during engine start-up
- Single pump can supply flow and regulate pressure for multiple circuits
- Quick response to system flow and pressure requirements

## General information

### PVBS, main spools with pressure compensated control

The PC control maintains constant system pressure in the hydraulic circuit by varying the output flow of the pump. Used with a closed center control valve, the pump remains in high pressure standby mode at the PC setting with zero flow until the function is actuated.

#### Typical operating curve

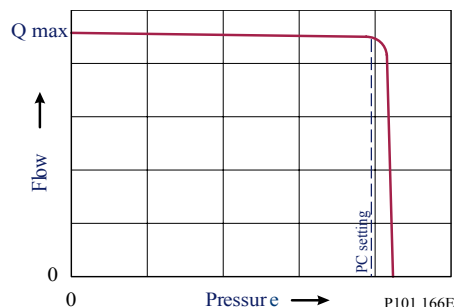

#### Simple closed center circuit

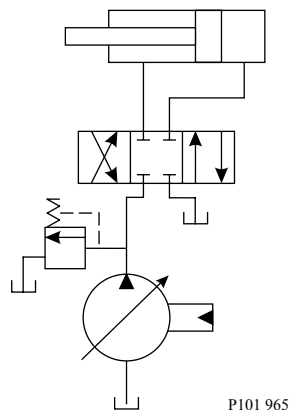

Once the closed center valve is opened, the PC control senses the immediate drop in system pressure and increases pump flow by increasing the swashplate angle.

The pump continues to increase flow until system pressure reaches the PC setting.

If system pressure exceeds the PC setting, the PC control reduces the swashplate angle to maintain system pressure by reducing flow. The PC control continues to monitor system pressure and changes swashplate angle to match the output flow with the work function pressure requirements.

If the demand for flow exceeds the capacity of the pump, the PC control directs the pump to maximum displacement. In this condition, actual system pressure depends on the actuator load.

[For additional system protection, install a relief valve in the pump outlet line.](#)

#### Pressure compensated system characteristics

- Constant pressure and variable flow
- High pressure standby mode when flow is not needed
- System flow adjusts to meet system requirements
- Single pump can provide flow to multiple work functions
- Quick response to system flow and pressure requirements



## General information

### **Typical applications for pressure compensated systems**

- Constant force cylinders (bailers, compactors, refuse trucks)
- On/off fan drives
- Drill rigs
- Sweepers
- Trenchers

## General information

### Remote pressure compensated controls

The remote PC control is a two-stage control that allows multiple PC settings. Remote PC controls are commonly used in applications requiring low and high pressure PC operation.

*Typical operating curve*

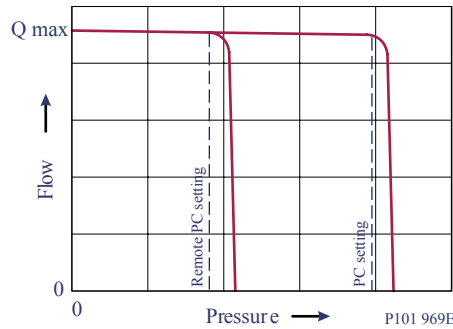

*Closed center circuit with remote PC*

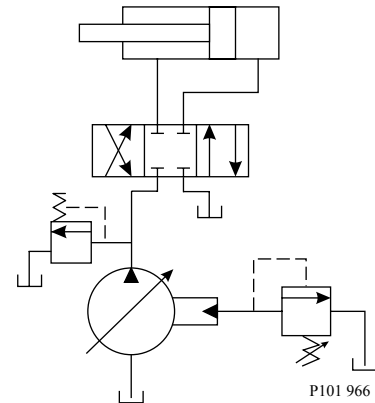

The remote PC control uses a pilot line connected to an external hydraulic valve. The external valve changes pressure in the pilot line, causing the PC control to operate at a lower pressure. When the pilot line is vented to reservoir, the pump maintains pressure at the load sense setting.

When pilot flow is blocked, the pump maintains pressure at the PC setting. An on-off solenoid valve can be used in the pilot line to create a low-pressure standby mode. A proportional solenoid valve, coupled with a microprocessor control, can produce an infinite range of operating pressures between the low pressure standby setting and the PC setting.

Size the external valve and plumbing for a pilot flow of 3.8 l/min [1 US gal/min]. For additional system protection, install a relief valve in the pump outlet line.

#### **Remote pressure compensated system characteristics:**

- Constant pressure and variable flow
- High or low pressure standby mode when flow is not needed
- System flow adjusts to meet system requirements
- Single pump can provide flow to multiple work functions
- Quick response to system flow and pressure requirements

#### **Typical applications for remote pressure compensated systems:**

- Modulating fan drives
- Anti-stall control with engine speed feedback
- Front wheel assist
- Road rollers
- Combine harvesters
- Wood chippers

## General information

### Open center PVP

Description of the example: PVG 32 with open center PVP (fixed displacement pump) and PVB with flow control spool.

When the pump is started and the main spools in the individual basic modules (**11**) are in the neutral position, oil flows from the pump, through connection P, across the pressure adjustment spool (**6**) to tank. The oil flow led across the pressure adjustment spool determines the pump pressure (stand-by pressure).

When one or more of the main spools are actuated, the highest load pressure is fed through the shuttle valve circuit (**10**) to the spring chamber behind the pressure adjustment spool (**6**), and completely or partially closes the connection to tank to maintain pump pressure. Pump pressure is applied to the right-hand side of the pressure adjustment spool.

The pressure relief valve (**1**) will open when the load pressure exceeds the set value, diverting pump flow back to tank.

In a pressure-compensated basic module the compensator (**14**) maintains a constant pressure drop across the main spool – both when the load changes and when a module with a higher load pressure is actuated.

With a non pressure-compensated basic module incorporating a load drop check valve (**18**) in channel P, the check valve prevents return oil flow.

The basic module can be supplied without the load drop check valve in channel P for functions with over-center valves.

The shock valves PVLP (**13**) with fixed setting and the suction valves PVLA (**17**) on ports A and B are used for the protection of the individual working function against overload and/or cavitation.

An adjustable LS pressure limiting valve (**12**) can be built into the A and B ports of pressure-compensated basic modules to limit the pressure from the individual working functions. The LS pressure limiting valves save energy compared with:

- PVLP all the oil flow to the working function will be led across the combined shock and suction valves to tank if the pressure exceeds the fixed setting.
- LS pressure limiting valves an oil flow of about 2 l/min [0.5 US gal/min] will be led across the LS pressure limiting valve to tank if the pressure exceeds the valve setting.

Please see the sectional drawing [Sectional view](#) on page 12 for better understanding of this example.

### Closed center PVP

Description of the example: PVG 32 with closed center PVP (variable displacement pump) and PVB with flow control spool.

In the closed center version of PVP an orifice (**5**) and a plug (**7**) have been fitted instead of the plug (**4**). This means that the pressure adjustment spool (**6**) will open to tank when the pressure in channel P exceeds the set value of the pressure relief valve (**1**). The pressure relief valve in PVP should be set at a pressure of approx. 30 bar [435 psi] above maximum system pressure (set on the pump or external pressure relief valve).

In load sensing systems the load pressure is led to the pump control via the LS connection (**8**). In the neutral position the pump load sense control sets the displacement so that leakage in the system is compensated, to maintain the set stand-by pressure. When a main spool is actuated the pump load sense control will adjust the displacement so that the set differential pressure (margin) between P and LS is maintained.

Please see the sectional drawing [Sectional view](#) on page 12 for better understanding of this example.

**Sectional view**

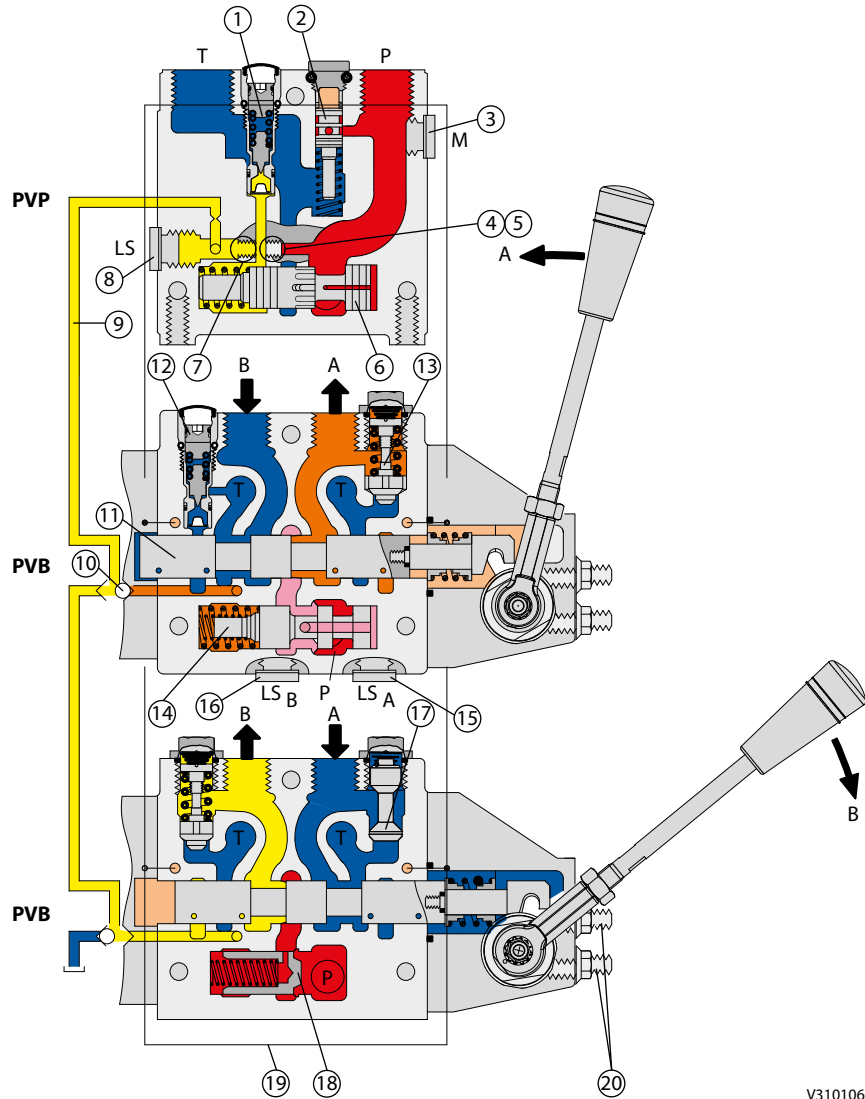

V310106.A

- |  |  |
|--|--|
| 1. Pressure relief valve                         | 11. Main spool                                       |
| 2. Pressure reduction valve for pilot oil supply | 12. LS pressure limiting valve                       |
| 3. Pressure gauge connection                     | 13. Shock and suction valve, PVL P                   |
| 4. Plug, open center                             | 14. Pressure compensator                             |
| 5. Orifice, closed center                        | 15. LS connection, port A                            |
| 6. Pressure adjustment spool                     | 16. LS connection, port B                            |
| 7. Plug, closed center                           | 17. Suction valve, PVLA                              |
| 8. LS connection                                 | 18. Load drop check valve                            |
| 9. LS signal                                     | 19. Pilot oil supply for PVE                         |
| 10. Shuttle valve                                | 20. Maximum oil flow adjustment screws for A/B ports |

## Safety in Application

All types of control valves (incl. proportional valves) can fail, thus the necessary protection against the serious consequences of function failure should always be built into the system. For each application an assessment should be made for the consequences of pressure failure and uncontrolled or blocked movements.

To determine the degree of protection that is required to be built into the application, system tools such as FMEA (Failure Mode and Effect Analysis) and Hazard and Risk Analysis can be used.

### FMEA – IEC EN 61508

FMEA (Failure Mode and Effect Analysis) is a tool used for analyzing potential risks. This analytical technique is utilized to define, identify, and prioritize the elimination or reduction of known and/or potential failures from a given system before it is released for production. Please refer to the standard IEC FMEA 61508.

### Hazard and risk analysis ISO 12100-1/14121

This analysis is a tool used in new applications as it will indicate whether there are special safety considerations to be met according to the machine directives EN 13849. Dependent on the determined levels conformity this analysis will determine if any extra requirements for the product design, development process, production process or maintenance, example the complete product life cycle.

### **Warning**

All brands and all types of directional control or proportional valves, which are used in many different operation conditions and applications, can fail and cause serious damage.  
 Analyze all aspects of the application. The machine builder/system integrator alone is responsible for making the final selection of the products and assuring that all performance, safety and warning requirements of the application are met. The process of choosing the control system and safety levels is governed by the machine directives EN 13849 (Safety related requirements for control systems).

## Example of a control system for manlift

*Example of a control system for man-lift*



### Safety in Application

Example of a control system for man-lift using PVE Fault monitoring input signals and signals from external sensors to ensure the PLUS+1® main controllers correct function of the man-lift.

*Typical PVE wiring block diagram*

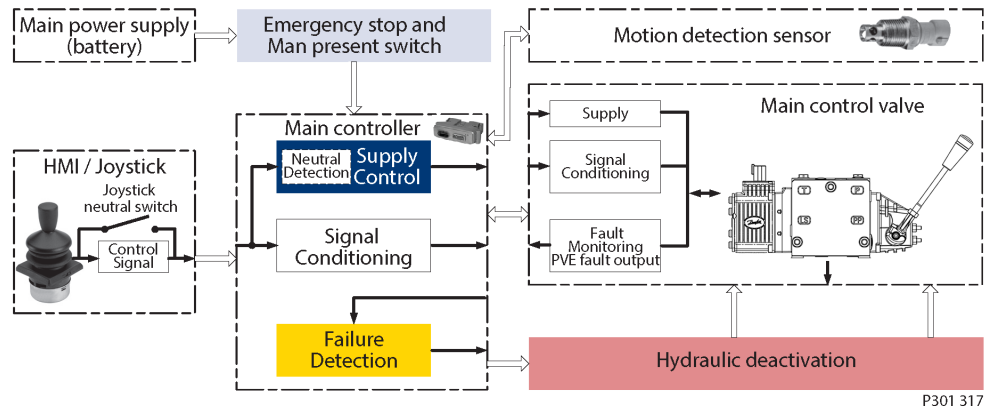

**Warning**

It is the responsibility of the equipment manufacturer that the control system incorporated in the machine is declared as being in conformity with the relevant machine directives.

### Safety in Application

#### PVG 32 – used in system with fixed displacement pumps:

- PVSK, commonly used in crane application - full flow dump
- PVPX, LS dump to tank

#### PVG 100 – alternative LS dump/pilot supply disconnect:

- PVPP, pilot oil supply shut off
- External cartridge valve connecting LS pressure or main pressure to tank

#### PVG 120 – pump disconnect/block for variable pumps:

- PVPE, full flow dump for the PVG 120
- External cartridge valve connecting LS pressure to tank

### Examples of wiring block diagram

Example 1

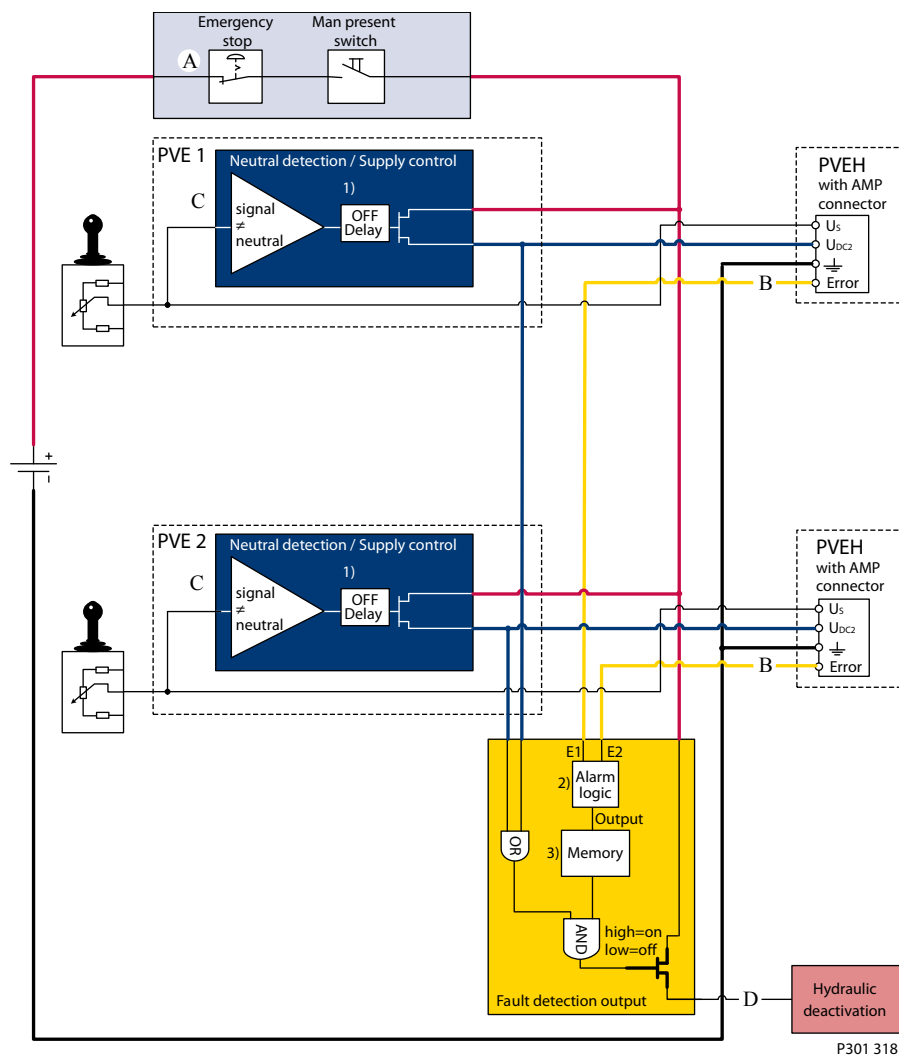

Typical wiring block diagram using PVEH with neutral power off switch and fault monitoring output for hydraulic deactivation.

**Safety in Application**

- A** Emergency stop / man present switch
- B** PVE Fault monitoring signals
- C** Neutral signal detection
- D** Deactivation of the hydraulic system (System Control Logic, example: PLUS+1® for signal monitoring and triggering signal)

**Warning**

It is the responsibility of the equipment manufacturer that the control system incorporated in the machine is declared as being in conformity with the relevant machine directives.

Example 2

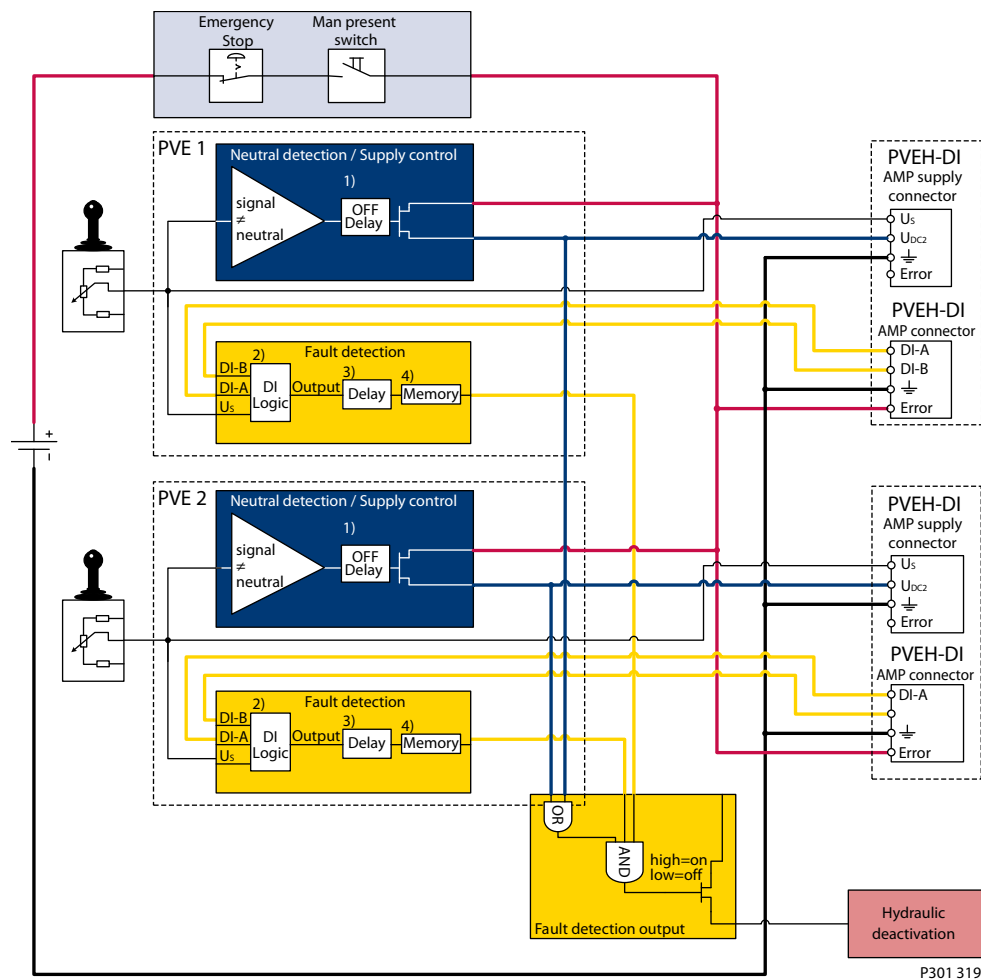

Fault monitoring for deactivation of the hydraulic system with extra fault inputs using the PVE's with DI (Direction Indication) function. System Control Logic, example PLUS+1® for signal monitoring and triggering signal for deactivation of the hydraulic system.

**Warning**

It is the responsibility of the equipment manufacturer that the control system incorporated in the machine is declared as being in conformity with the relevant machine directives.



## Assembly instructions

### PVG 16 and 32 general conditions

The specification sheet is compiled by the sales department for assembly of a new PVG 16 and PVG 32 valve groups.

1. Before, during and after the assembly/disassembly of new PVG groups, absolute cleanliness and care must be observed with regard to internal and external parts of the units concerned.
2. Use non-volatile, petroleum based solutions for cleaning valves and/or modules.
3. Replace all parts considered likely to cause malfunction during subsequent testing.
4. Replace all loose O-rings (without exceptions) with new O-rings.
5. Lubricate all moving parts with hydraulic oil before assembly.
6. Lubricate all O-rings with petroleum jelly.

[Refer to Service Manual BC152886483583 for module designations, item and spare parts numbers.](#)

## Assembly

The basic assembly sequence for PVG 16 and PVG 32 group is as follows:

1. Starting from the end plate place the module with (PVS, PVSP, PVSK) the tie rod bolts with the long threaded end pointing upwards ready for mounting of PVB modules.
2. Place all lubricated O-rings in their respective grooves in the different modules.
3. Locate the basic modules (PVB) against the PVP (PVS, PVSP, PVSK) using the tie rod bolts for alignment between the PVP and the PVB modules making sure the LS shuttle valve is able to move freely.
4. Place the PVP (the PVS if a valve group has midinlet, or HIC) as the last module and place the washers and nuts in position and hand tighten the valve.
5. Place the valve on a plain and level surface and tighten the assembly to a torque of  $28 \pm 2 \text{ N}\cdot\text{m}$  ( $247.8 \pm 17 \text{ lbf}\cdot\text{in}$ ) using a 13 mm socket. Max. level tolerance is 0.5 mm per section e.g. this means with 8 PVB sections max. allowable height difference between the mounting holes would be 4 mm (this would also be seen as a twist in the valve group assembly).

[The valve assembly is to be assembled in accordance with the specification sheet.](#)

6. Install the spools (PVBS) into the PVB's.

The assembled spool is marked with two four-digit numbers

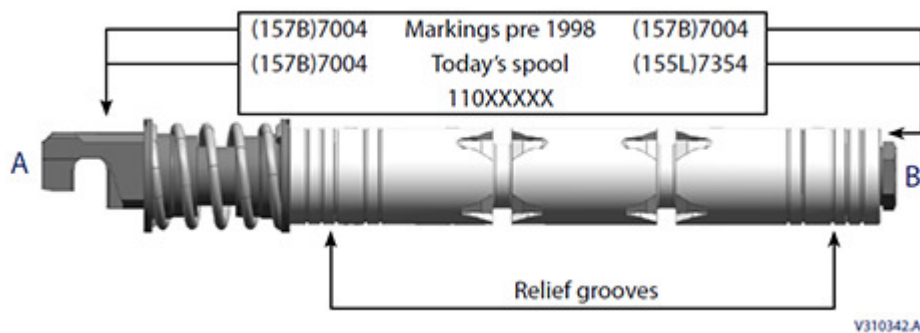

The number in the end of the spool where the plug is fitted, "B", is the drawing number of the spool and indicates that this end must face towards the "B" port of the valve.

The other number, stamped on the side the PVBS pull rod "A", is the module number of the assembled main spool.

For spool assemblies with remote hydraulic spools, the centering spring is different. The standard spring has a wire diameter of 1.9 mm. The remote hydraulic spring (5-15 bar) has a wire diameter of 2.8 mm.

**Assembly instructions**

PVG 32 is symmetrical, which allows for PVG 32 valve groups to be “option mounted” This can be done by inserting the spools from the “B” port side and mounting the PVM’s on the “B” port side of the PVB assembly. "Option mounting" is not possible with the PVG 16.

7. Assemble the mechanical actuators to the valve (see the figure below). Before fitting the PVM into engagement with the PVBS tension rod, the driver arm must be pushed towards the PVB before engagement will occur.  
Once the driver arm is engaged, rotate the mechanical actuator while pressing the PVM until the PVM is flush against the PVB housing.

Tighten the four (4) mounting screws to a torque of 0.8 +0/-0.5 N·m [70 +0/-4.5 lbf·in] using a 5 mm hex driver.

*Assembly of PVE, electrical actuation / Assembly of PVM, mechanical actuation*

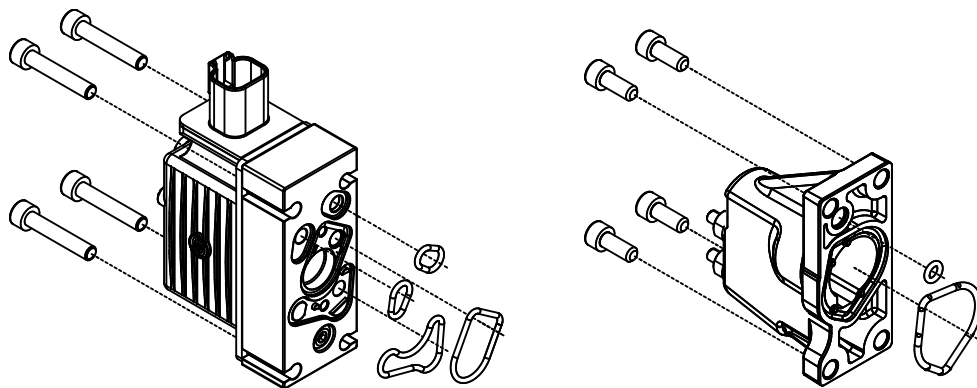

*Assembly of PVG 16*

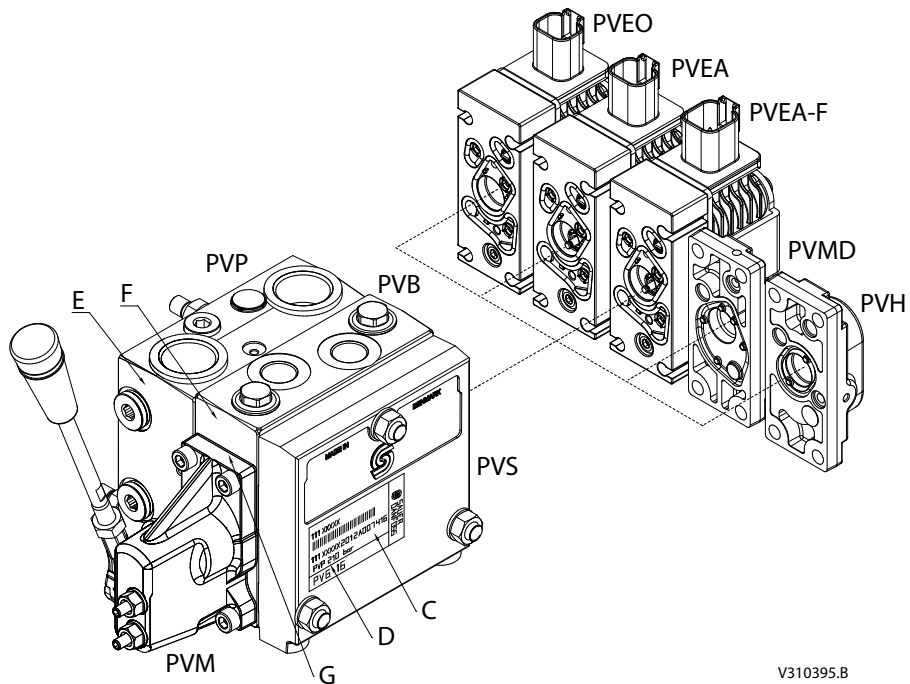

V310395.B

**Assembly instructions**

*Assembly of PVG 32*

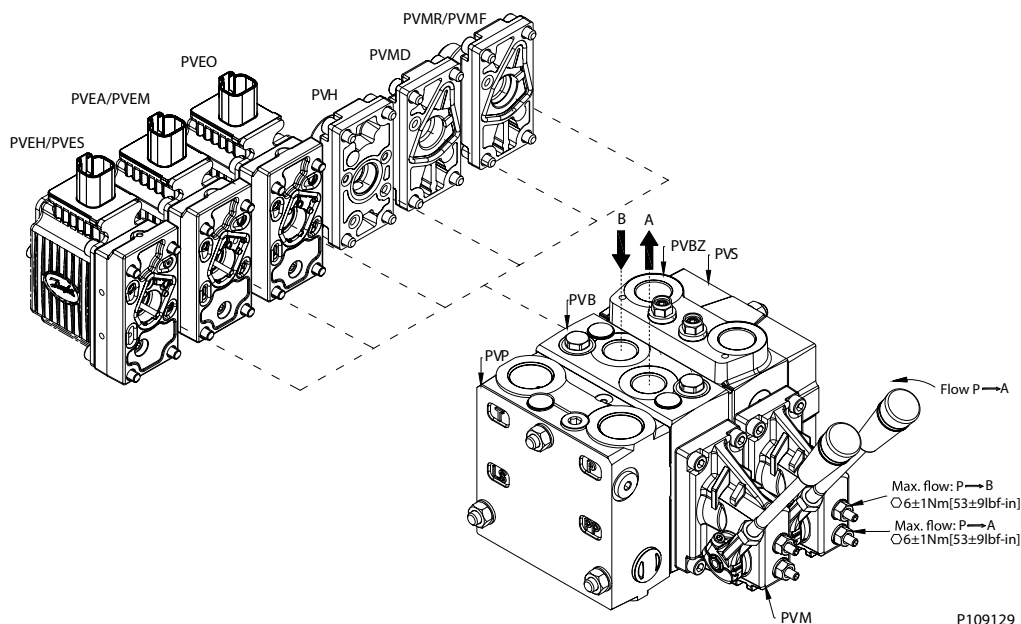

8. Assemble the actuators. The manual cover PVMD or the remote hydraulic end cover must be installed with the arrow pointing upwards towards the "A/B" port.

The PVE's must be installed with the connectors pointing upwards towards the "A/B" port. The torque for the four (4) mounting screws is  $0.8 + 0/-0.5 \text{ N}\cdot\text{m}$  [ $70 + 0/-4.5 \text{ in. lbs.}$ ] using a 5 mm hex drive.

Common to all types of PVE's is a small nylon filter in the "P" channel, under the O-ring. Insure that the transducer stem on the PVE's with closed loop feedback interfaces with the end of the PVBS without any restrictions.

New and unused PVE units can be mounted without neutral adjustment to the LVDT transducer. If an adjustment is required, contact the service department.

For control options with mechanical detent (PVMR) or mechanical float (PVMF) function, please follow instructions in the previous section describing assembly of the PVMD or PVH remote with reference to the below pictures.

*Assembly of the actuators*

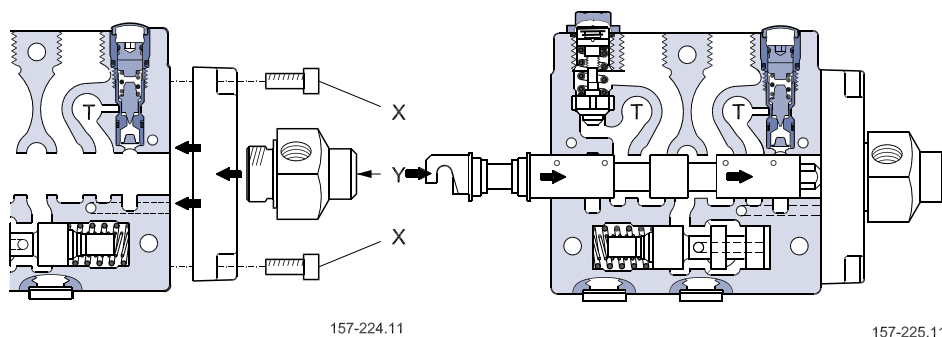

**Assembly instructions**

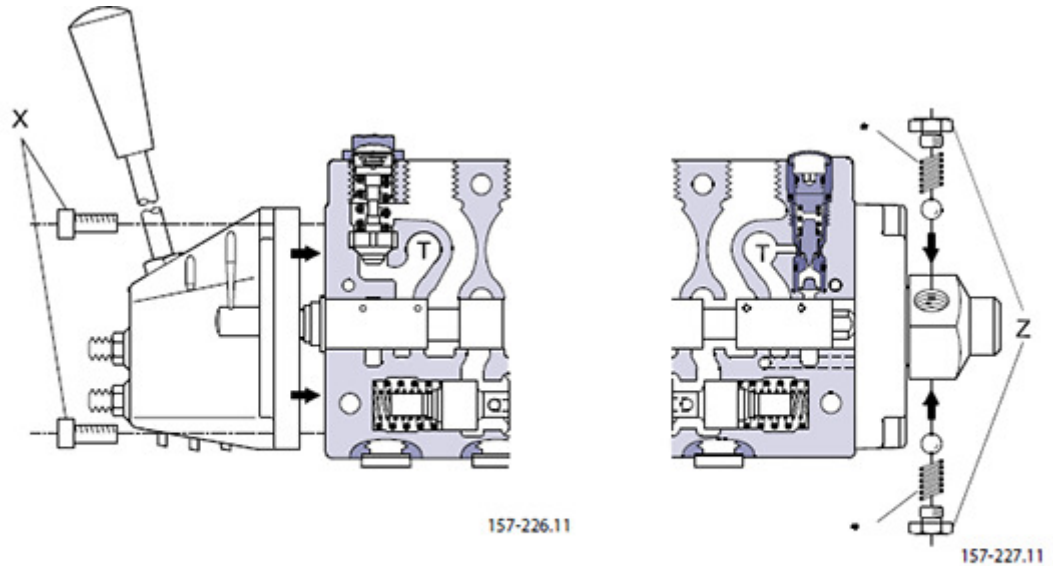

*	Spring Identification
PVMF	Painted blue
PVMR	Non-painted

For torque tightening values of the large hexagon (Y) with the detent assembly function, please see the table below.

*Tightening torques and widths across flats*

	X	Y	Z
With across flats			
Tightening torque	8 ± 0.5 N·m [70 ± 4.5 lbf·in]	15 ± 2 N·m [135 ± 20 lbf·in]	4 ± 1 N·m [35 ± 9 lbf·in]

*PVMR, detent option without a neutral spring*

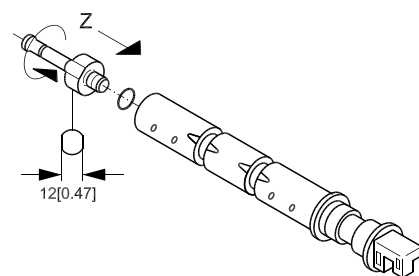

157-219.12

*PVMF, mechanical float option*

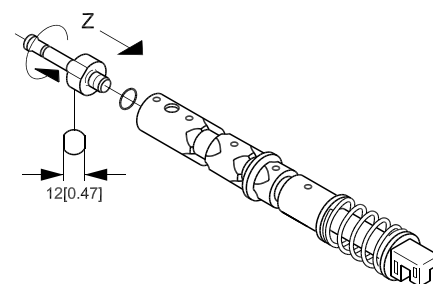

157-221.12

The valve assembly is to be assembled in accordance with the specification sheet.

- Assemble the shock/check (PVL) valves into the PVB's. The top of the PVL valve is marked with the last three digits of the module code number. This number also indicates the valve pressure setting @ 15.1 l/min [4 US gal/min]. Be careful not to swap plugs and valves. The PVLA module carries no markings. The torque for the plug is 40.0 ± 0.3 N·m [355 ± 25 lbf·in].

Assembly instructions

10. Issue/attach label with PVG code no. for the valve assembly.

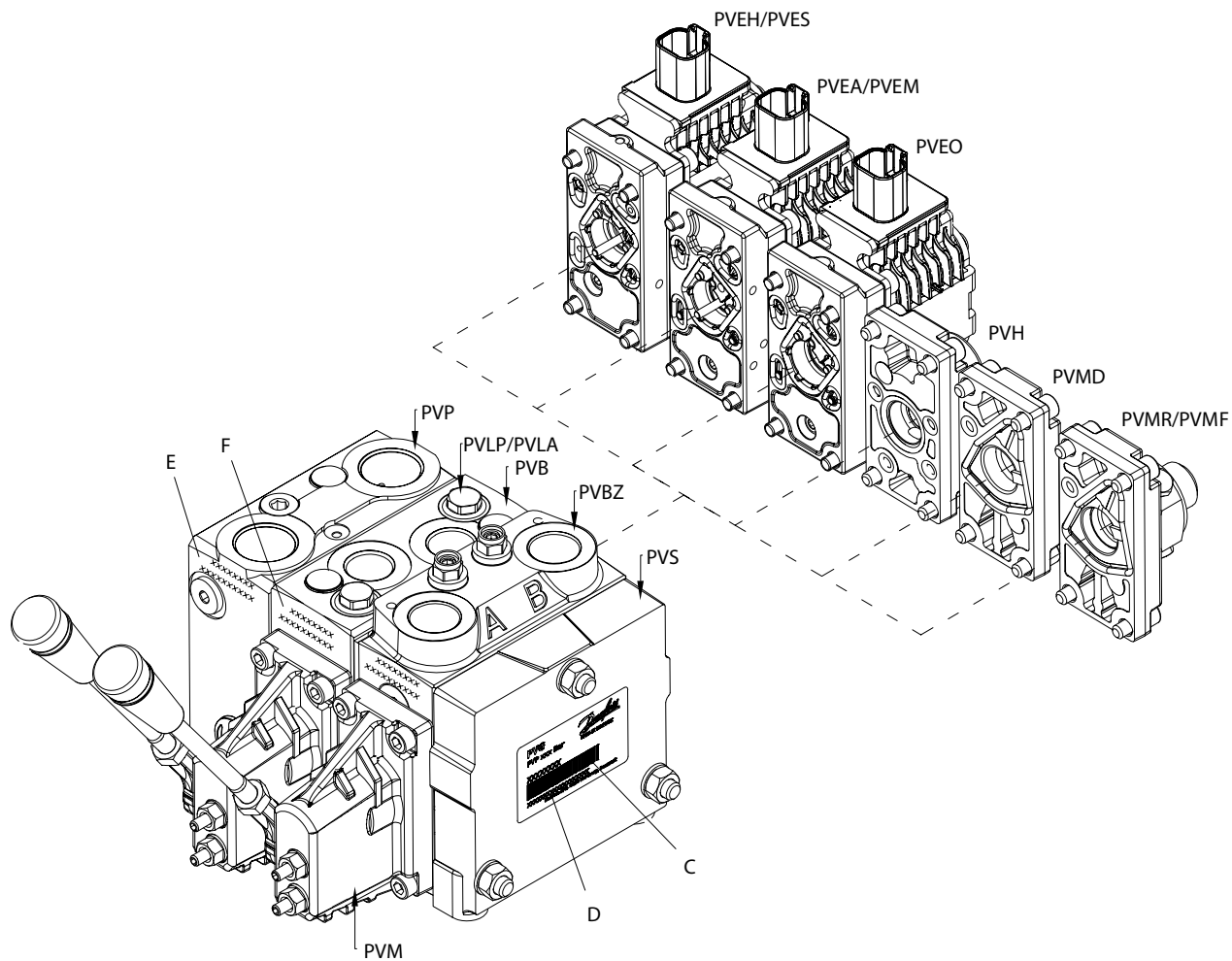

## Testing

### PVG 16 and 32 leak test

After all components have been assembled and tightened to the proper specifications, a leak test with compressed air must be performed.

1. Block off all "A" and "B" ports with steel plugs.
2. Block off the "P" port with a steel plug in the PVP. Screw the compressed air connection into the "T" port. (see the figure below).

*Block diagram*

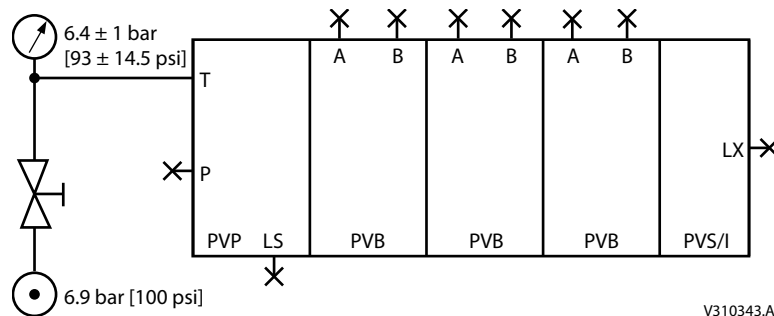

3. Apply compressed air at 6.9 bar [100 psi] for 5 minutes. At the same time, activate all PVM control levers in order to fill all channels, chambers and cavities with an air.
4. Shut off the compressed air so that pressure is confined in the entire valve.  
The permissible pressure drop in the valve is 0.5 bar [7 psi] per minute maximum. Small leaks can be traced by pouring a small amount of oil onto the place where the leak is thought to be present.
5. Try correcting small leaks by retightening the assembly. Large leaks usually indicate forgotten or squeezed O-rings.

### Pressure setting after assembly

All relief valves must be set with a gauge located in the gauge port of the PVP.

- Groups with CLOSED CENTER PVP'S can be tested as assembled for all pressure relief settings.
- Groups with OPEN CENTER PVP'S and PVB'S with shock valves (PVL) and LS<sub>A</sub>/LS<sub>B</sub> valves with opening pressure lower than the pressure setting in the PVP. The PVP must be modified temporarily to CLOSED CENTER. After the relief settings are made, the PVP must be corrected to OPEN CENTER. All other with OPEN CENTER PVP'S can be tested as assembled.
- The PVP and LS<sub>A</sub>/LS<sub>B</sub> pressure relief valves must be set by applying oil pressure on the "P" port in the PVP. The "T" port must be connected to tank.
- All "A" and "B" ports must be blocked off with steel plugs.
- The quantity of oil supplied to the valve assembly must be at least 15 +/- 2 L/min [4 +/- 0.45 US gal/min].
- The CLOSED CENTER PVP module can be set by applying pressure to the "P" port.
- The OPEN CENTER PVP module can be set by applying pressure to the "P" port and activating the spool in the A or B direction dead heading the A or B port.
- It is assumed that the PVP module has a higher setting than the LS<sub>A</sub>/LS<sub>B</sub> valves. LS<sub>A</sub>/LS<sub>B</sub> valves must be set one at a time by activating the spool in the PVB section in the direction of the LS valve to be adjusted.
- Adjustment of the relief valve is accomplished by using a 4 mm hex wrench.

## Testing

For relief valve version and location please see the figure

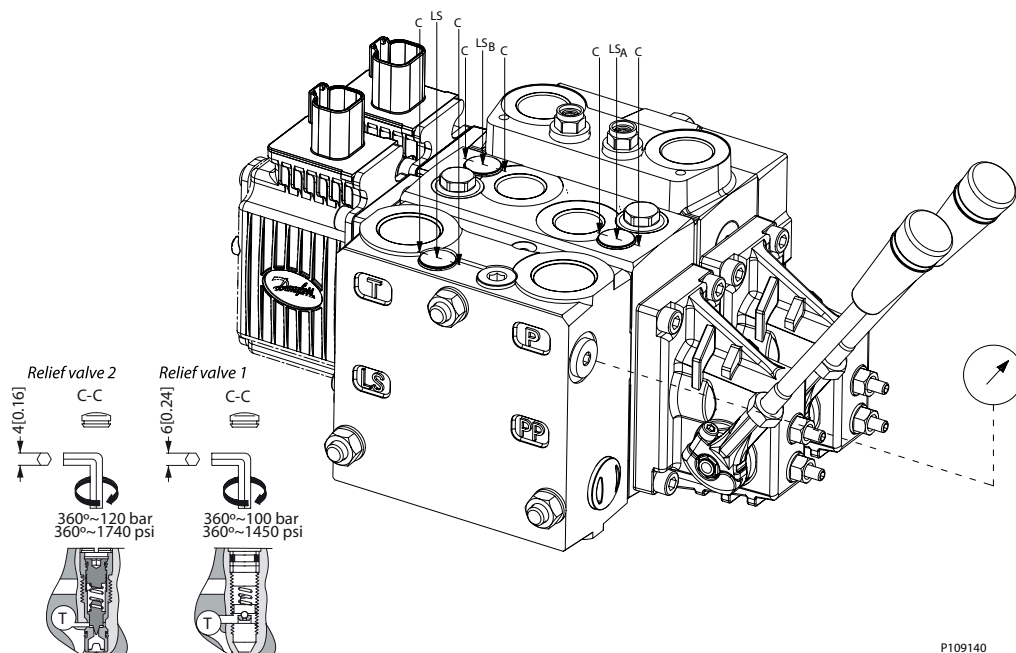

### PVG 16 and 32 function testing

Function testing insures the correct dynamic manual and electrical operation of the PVG 16 and PVG 32 valve assembly. This test should be performed after completing the pressure adjustments. Each section of the assembly must be tested:

1. With the pump connected, remove the plugs from the section to be tested as described in the [Pressure setting after assembly](#) on page 22 section. Connect the "A" port of the valve to the rod end of the cylinder and the "B" port to the base end of the cylinder (see the figure below).

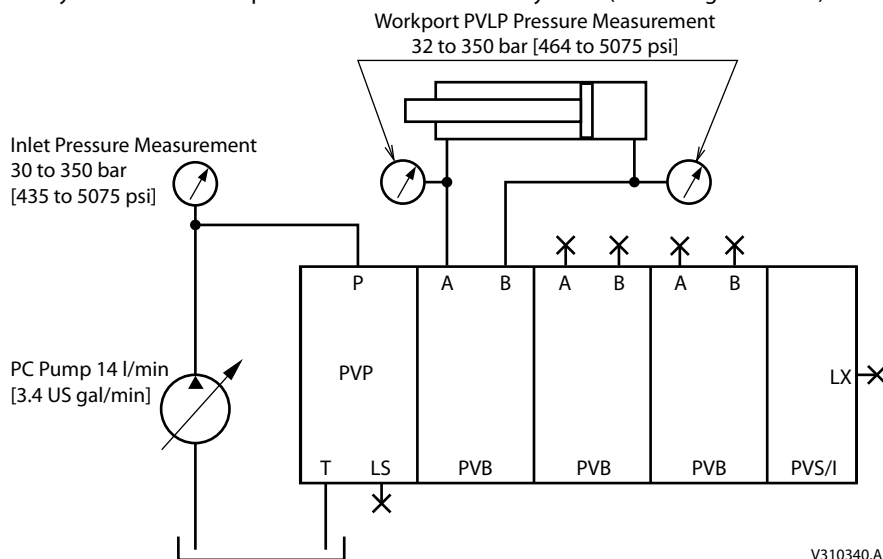

2. Shift the control lever of the tested section towards the valve and observe cylinder retraction. Shift the same control lever away from the valve and observe cylinder extension. Repeat several times. On valve groups with PVM's on the "B" side, the cylinder movement will be opposite when shifting the handle in the same direction.
3. Check the spool travel smoothness in both directions.

## Testing

4. Check the metering of the spool in both directions. Can you control the speed of the cylinder/motor, slow/fast?
5. Check to see if the LS signal at the PVP drops off, when the spool is in the neutral position. This signal also should not build up pressure in the neutral position.
6. Shift the spool to one direction manually and let go of the control lever. The valve should center itself. If the control lever sticks in any position, check for binding of the spool. This is to be checked in both directions.
7. Utilizing a controller package, connect the EL-PLUG connector to the PVE. Set the controller to the corresponding PVE. Insure that the proper voltage and joystick are being used. Similar to manual testing of the valve, eclectically shift the valve to allow flow out the "A" port.  
  
Check to see if the PVM control level shifts in the correct direction. This should also be done in the "B" direction. Check to insure that once the controller is not activated the valve centers itself. Observe that the spool responds to any change in the signal from the joystick. Any change in position of the joystick should relate to a change in the PVM control lever. Check the metering of the PVEM/H's.
8. After all sections have been tested, insure that all relief valves are adjusted correctly. Refer to the section [Pressure setting after assembly](#) on page 22 for any adjustments.
9. Remove all steel plugs, fittings and hoses. Drain the oil from the valve group. Install plastic plugs in all ports & rubber cap (155L6377) over all pressure adjustments.
10. A certified PVG valve test report must be completed & accompany every valve, e.g. see PVG 32 [Test report](#) on page 25 on the next page.

---

[Sections with open ported spools will experience cylinder extension in the neutral position.](#)

---

### **Recommended equipment and hand tools to assemble PVG 16 and PVG 32:**

- Socket driver, Allen wrench = 2.5, 3, 4, 5, 6, 8 mm.
- Sockets = 3/8 drive deep well 13 mm.
- Combo – wrenches = 10, 13 mm
- Torque wrench = 3/8 drive 0 – 10 N•m [0-885 in. lbs.]
- Ball driver hex = 4, 5, 6, 8 mm
- Plastic hammer



# Service Manual

## PVG 16 and 32 Service Assembly/Disassembly Guide

### Test report

TEST REPORT		Customer: _____		
PROPORTIONAL VALVE PVG 32		PVG NO. _____		
For Test Procedures Refer to Service Assembly/Disassembly Guide L1106530				
FUNCTION	A-Port	0 Specified Relief Setting: _____ bar Relief Set at: _____ bar Inlet condition Open: _____ Closed: _____	B-Port	Control Type and Serial No.
Manual Operation: _____ Detent Operation: _____ Hydraulic Operation: _____ Solenoid Operation: _____	Tested OK? <input type="checkbox"/>	1 Spool Code verified: _____ LS x Specified: _____ Set: _____ bar LS y Specified: _____ Set: _____ bar	Tested OK? <input type="checkbox"/>	157 _____ SN _____
Shocks _____	Specified Setting _____ bar		Specified Setting _____ bar	
Manual Operation: _____ Detent Operation: _____ Hydraulic Operation: _____ Solenoid Operation: _____	Tested OK? <input type="checkbox"/>	2 Spool Code verified: _____ LS x Specified: _____ Set: _____ bar LS y Specified: _____ Set: _____ bar	Tested OK? <input type="checkbox"/>	157 _____ SN _____
Shocks _____	Specified Setting _____ bar		Specified Setting _____ bar	
Manual Operation: _____ Detent Operation: _____ Hydraulic Operation: _____ Solenoid Operation: _____	Tested OK? <input type="checkbox"/>	3 Spool Code verified: _____ LS x Specified: _____ Set: _____ bar LS y Specified: _____ Set: _____ bar	Tested OK? <input type="checkbox"/>	157 _____ SN _____
Shocks _____	Specified Setting _____ bar		Specified Setting _____ bar	
Manual Operation: _____ Detent Operation: _____ Hydraulic Operation: _____ Solenoid Operation: _____	Tested OK? <input type="checkbox"/>	4 Spool Code verified: _____ LS x Specified: _____ Set: _____ bar LS y Specified: _____ Set: _____ bar	Tested OK? <input type="checkbox"/>	157 _____ SN _____
Shocks _____	Specified Setting _____ bar		Specified Setting _____ bar	
Manual Operation: _____ Detent Operation: _____ Hydraulic Operation: _____ Solenoid Operation: _____	Tested OK? <input type="checkbox"/>	5 Spool Code verified: _____ LS x Specified: _____ Set: _____ bar LS y Specified: _____ Set: _____ bar	Tested OK? <input type="checkbox"/>	157 _____ SN _____
Shocks _____	Specified Setting _____ bar		Specified Setting _____ bar	
Manual Operation: _____ Detent Operation: _____ Hydraulic Operation: _____ Solenoid Operation: _____	Tested OK? <input type="checkbox"/>	6 Spool Code verified: _____ LS x Specified: _____ Set: _____ bar LS y Specified: _____ Set: _____ bar	Tested OK? <input type="checkbox"/>	157 _____ SN _____
Shocks _____	Specified Setting _____ bar		Specified Setting _____ bar	
Manual Operation: _____ Detent Operation: _____ Hydraulic Operation: _____ Solenoid Operation: _____	Tested OK? <input type="checkbox"/>	7 Spool Code verified: _____ LS x Specified: _____ Set: _____ bar LS y Specified: _____ Set: _____ bar	Tested OK? <input type="checkbox"/>	157 _____ SN _____
Shocks _____	Specified Setting _____ bar		Specified Setting _____ bar	
Manual Operation: _____ Detent Operation: _____ Hydraulic Operation: _____ Solenoid Operation: _____	Tested OK? <input type="checkbox"/>	8 Spool Code verified: _____ LS x Specified: _____ Set: _____ bar LS y Specified: _____ Set: _____ bar	Tested OK? <input type="checkbox"/>	157 _____ SN _____
Shocks _____	Specified Setting _____ bar		Specified Setting _____ bar	
Manual Operation: _____ Detent Operation: _____ Hydraulic Operation: _____ Solenoid Operation: _____	Tested OK? <input type="checkbox"/>	9 Spool Code verified: _____ LS x Specified: _____ Set: _____ bar LS y Specified: _____ Set: _____ bar	Tested OK? <input type="checkbox"/>	157 _____ SN _____
Shocks _____	Specified Setting _____ bar		Specified Setting _____ bar	
Manual Operation: _____ Detent Operation: _____ Hydraulic Operation: _____ Solenoid Operation: _____	Tested OK? <input type="checkbox"/>	10 Spool Code verified: _____ LS x Specified: _____ Set: _____ bar LS y Specified: _____ Set: _____ bar	Tested OK? <input type="checkbox"/>	157 _____ SN _____
Shocks _____	Specified Setting _____ bar		Specified Setting _____ bar	
Manual Operation: _____ Detent Operation: _____ Hydraulic Operation: _____ Solenoid Operation: _____	Tested OK? <input type="checkbox"/>	11 Spool Code verified: _____ LS x Specified: _____ Set: _____ bar LS y Specified: _____ Set: _____ bar	Tested OK? <input type="checkbox"/>	157 _____ SN _____
Shocks _____	Specified Setting _____ bar		Specified Setting _____ bar	
Manual Operation: _____ Detent Operation: _____ Hydraulic Operation: _____ Solenoid Operation: _____	Tested OK? <input type="checkbox"/>	12 Spool Code verified: _____ LS x Specified: _____ Set: _____ bar LS y Specified: _____ Set: _____ bar	Tested OK? <input type="checkbox"/>	157 _____ SN _____
Shocks _____	Specified Setting _____ bar		Specified Setting _____ bar	
All Codes Correct? <input type="checkbox"/> Assembly Bolts Torqued? <input type="checkbox"/> Re-Torqued after Test? <input type="checkbox"/> MID.A. Labels Fitted? <input type="checkbox"/> Solenoid Test Voltage _____ B/No. & Date Stamp on Endplate? _____ No. of Valve Builds _____ Build: _____ of 1		LP Pressure setting: _____ Any Special Requirements? _____ (describe below) _____ _____ Checked? <input type="checkbox"/> Any Documents to Accompany Valve? _____ <b>BUILD SHEET AND TEST REPORTS</b> _____ Checked? <input type="checkbox"/>		
Tested by: <input type="text"/> Date: <input type="text"/>				

**Order specifications**

PVG 16 specification sheet



**PVG 16**  
**Specification Sheet**

Subsidiary / Dealer	PVG No.
Customer	Customer No.
Application	Revision No.

	Function	A-port	B-port
0	Inlet	P = bar	
1	a	f LS <sub>A</sub> = bar LS <sub>B</sub> = bar	e c
	b		b
2	a	f LS <sub>A</sub> = bar LS <sub>B</sub> = bar	e c
	b		b
3	a	f LS <sub>A</sub> = bar LS <sub>B</sub> = bar	e c
	b		b
4	a	f LS <sub>A</sub> = bar LS <sub>B</sub> = bar	e c
	b		b
5	a	f LS <sub>A</sub> = bar LS <sub>B</sub> = bar	e c
	b		b
6	a	f LS <sub>A</sub> = bar LS <sub>B</sub> = bar	e c
	b		b
7	a	f LS <sub>A</sub> = bar LS <sub>B</sub> = bar	e c
	b		b
8	a	f LS <sub>A</sub> = bar LS <sub>B</sub> = bar	e c
	b		b
9	a	f LS <sub>A</sub> = bar LS <sub>B</sub> = bar	e c
	b		b
10	a	f LS <sub>A</sub> = bar LS <sub>B</sub> = bar	e c
	b		b
11	End section		
12	PVAS section		
13	Reserved for painting		

Comments
Filled in by _____ Date _____

**Order specifications**

PVG 32 specification sheet



**PVG 32  
 Specification Sheet**

Subsidiary / Dealer	PVG No.
Customer	Customer No.
Application	Revision No.

Function	A-port	B-port
<b>0</b> Inlet		P = bar
<b>1</b>	a f b LS <sub>A</sub> = bar LS <sub>B</sub> = bar	e c bar
<b>2</b>	a f b LS <sub>A</sub> = bar LS <sub>B</sub> = bar	e c bar
<b>3</b>	a f b LS <sub>A</sub> = bar LS <sub>B</sub> = bar	e c bar
<b>4</b>	a f b LS <sub>A</sub> = bar LS <sub>B</sub> = bar	e c bar
<b>5</b>	a f b LS <sub>A</sub> = bar LS <sub>B</sub> = bar	e c bar
<b>6</b>	a f b LS <sub>A</sub> = bar LS <sub>B</sub> = bar	e c bar
<b>7</b>	a f b LS <sub>A</sub> = bar LS <sub>B</sub> = bar	e c bar
<b>8</b>	a f b LS <sub>A</sub> = bar LS <sub>B</sub> = bar	e c bar
<b>9</b>	a f b LS <sub>A</sub> = bar LS <sub>B</sub> = bar	e c bar
<b>10</b>	a f b LS <sub>A</sub> = bar LS <sub>B</sub> = bar	e c bar
<b>11</b>	a f b LS <sub>A</sub> = bar LS <sub>B</sub> = bar	e c bar
<b>12</b>	a f b LS <sub>A</sub> = bar LS <sub>B</sub> = bar	e c bar
<b>13</b>	a f b LS <sub>A</sub> = bar LS <sub>B</sub> = bar	e c bar
<b>14</b>	a f b LS <sub>A</sub> = bar LS <sub>B</sub> = bar	e c bar
<b>15</b> End section		
<b>16</b> PVAS section		
<b>17</b> Reserved for painting		

Comments	
Filled in by	Date

### Products we offer:

- Cartridge valves
- DCV directional control valves
- Electric converters
- Electric machines
- Electric motors
- Gear motors
- Gear pumps
- Hydraulic integrated circuits (HICs)
- Hydrostatic motors
- Hydrostatic pumps
- Orbital motors
- PLUS+1® controllers
- PLUS+1® displays
- PLUS+1® joysticks and pedals
- PLUS+1® operator interfaces
- PLUS+1® sensors
- PLUS+1® software
- PLUS+1® software services, support and training
- Position controls and sensors
- PVG proportional valves
- Steering components and systems
- Telematics

**Danfoss Power Solutions** is a global manufacturer and supplier of high-quality hydraulic and electric components. We specialize in providing state-of-the-art technology and solutions that excel in the harsh operating conditions of the mobile off-highway market as well as the marine sector. Building on our extensive applications expertise, we work closely with you to ensure exceptional performance for a broad range of applications. We help you and other customers around the world speed up system development, reduce costs and bring vehicles and vessels to market faster.

Danfoss Power Solutions – your strongest partner in mobile hydraulics and mobile electrification.

### Go to [www.danfoss.com](http://www.danfoss.com) for further product information.

We offer you expert worldwide support for ensuring the best possible solutions for outstanding performance. And with an extensive network of Global Service Partners, we also provide you with comprehensive global service for all of our components.

Local address:

### Hydro-Gear

[www.hydro-gear.com](http://www.hydro-gear.com)

### Daikin-Sauer-Danfoss

[www.daikin-sauer-danfoss.com](http://www.daikin-sauer-danfoss.com)

**Danfoss  
Power Solutions (US) Company**  
2800 East 13th Street  
Ames, IA 50010, USA  
Phone: +1 515 239 6000

**Danfoss  
Power Solutions GmbH & Co. OHG**  
Krokamp 35  
D-24539 Neumünster, Germany  
Phone: +49 4321 871 0

**Danfoss  
Power Solutions ApS**  
Nordborgvej 81  
DK-6430 Nordborg, Denmark  
Phone: +45 7488 2222

**Danfoss  
Power Solutions Trading  
(Shanghai) Co., Ltd.**  
Building #22, No. 1000 Jin Hai Rd  
Jin Qiao, Pudong New District  
Shanghai, China 201206  
Phone: +86 21 2080 6201

Danfoss can accept no responsibility for possible errors in catalogues, brochures and other printed material. Danfoss reserves the right to alter its products without notice. This also applies to products already on order provided that such alterations can be made without subsequent changes being necessary in specifications already agreed. All trademarks in this material are property of the respective companies. Danfoss and the Danfoss logotype are trademarks of Danfoss A/S. All rights reserved.