



Installation Guide Danfoss Turbocor



Contents

| | |
|--|-----------|
| 1 Introduction | 3 |
| 1.1 Product Overview | 3 |
| 1.2 Purpose of the Manual | 4 |
| 1.3 Product Overview | 4 |
| 1.4 Internal Controller Functions | 4 |
| 2 Safety | 5 |
| 2.1 Safety Symbols | 5 |
| 3 Installation | 6 |
| 3.1 Planning the Installation Site | 6 |
| 3.2 Pre-Installation Check List | 6 |
| 3.3 Mechanical Installation | 6 |
| 3.3.1 Cooling | 6 |
| 3.3.1.1 Refrigerant Cooling | 6 |
| 3.3.2 Lifting | 7 |
| 3.3.3 Wall Mounting - IP21 (NEMA 1) Units | 7 |
| 3.4 Electrical Installation | 7 |
| 3.4.1 General Requirements | 7 |
| 3.4.2 Grounding Requirements | 10 |
| 3.4.2.1 Leakage Current (>3.5 mA) | 10 |
| 3.4.2.2 Grounding IP21 Enclosures | 11 |
| 3.4.3 Motor Connection | 11 |
| 3.4.3.1 Terminal Locations | 12 |
| 3.4.4 Motor Cable | 13 |
| 3.4.5 Motor Rotation Check | 13 |
| 3.4.6 AC Mains Connection | 13 |
| 3.4.7 DC-Link Connection | 13 |
| 3.5 Control Wiring Connection | 14 |
| 3.5.1 Access | 14 |
| 3.5.2 Using Screened Control Cables | 14 |
| 3.5.3 Grounding of Screened Control Cables | 14 |
| 3.5.4 Control Terminal Types | 15 |
| 3.5.5 Wiring to Control Terminals | 16 |
| 3.6 Serial Communication | 16 |
| 4 Start Up and Commissioning | 17 |
| 4.1 Pre-start | 17 |
| 4.2 Applying Power | 18 |

| | |
|---|----|
| 5 Specifications | 19 |
| 5.1 Power-dependent Specifications | 19 |
| 5.2 General Technical Data | 20 |
| 5.3 Fuse Tables | 22 |
| 5.3.1 Protection | 22 |
| 5.3.2 Fuse Selection | 22 |
| 5.3.3 Short Circuit Current Rating (SCCR) | 23 |
| 5.3.4 Connection Tightening Torques | 23 |
| Index | 24 |

1 Introduction

1.1 Product Overview

1.1.1 Interior Views

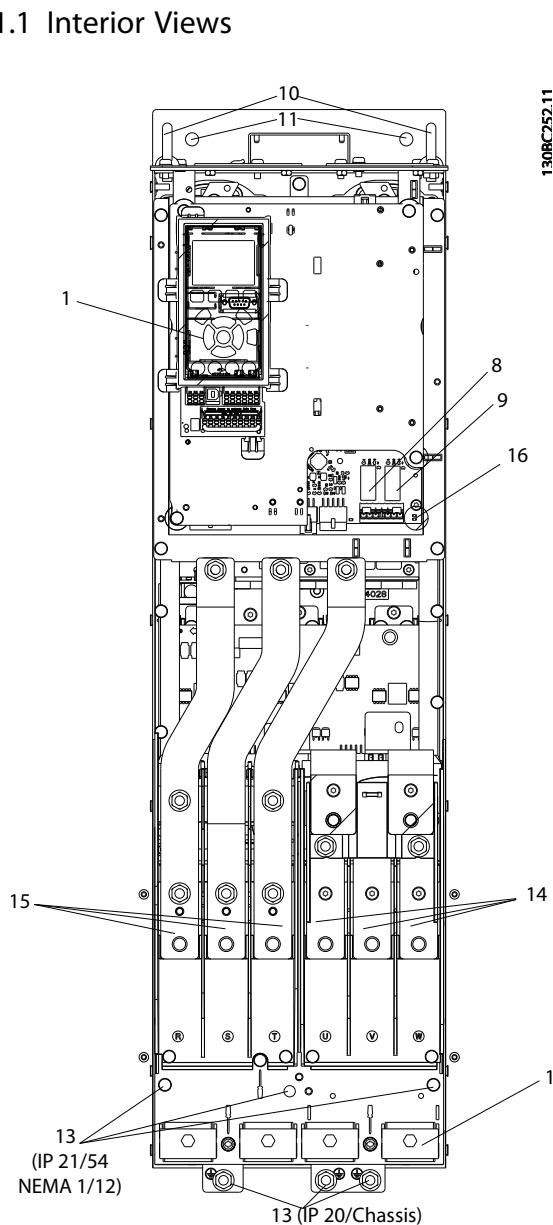

Illustration 1.1 D1 Interior Components

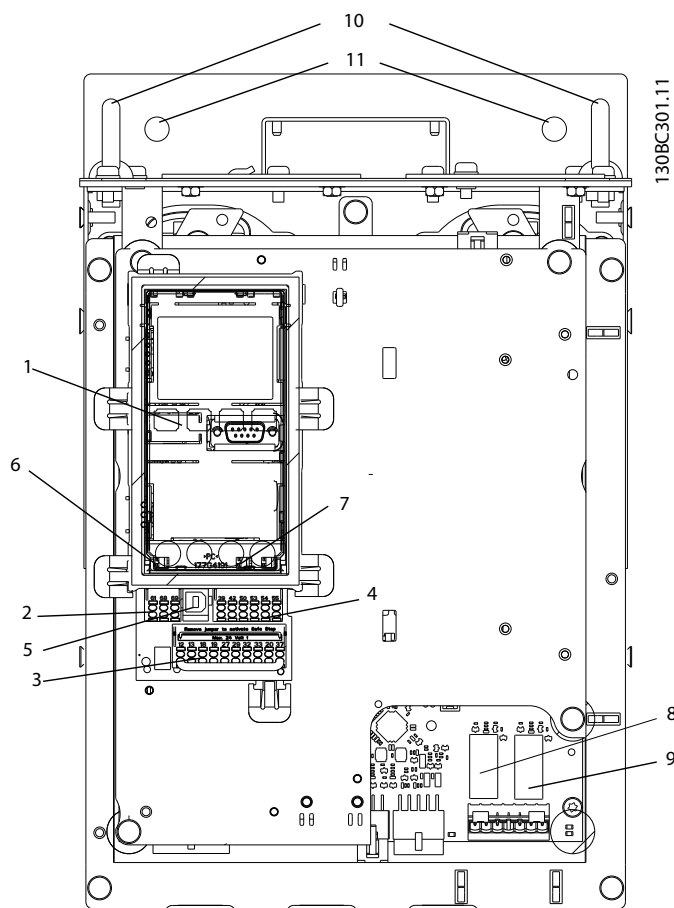

Illustration 1.2 Close-up View: LCP and Control Functions

| | | | |
|---|-----------------------------------|----|--|
| 1 | LCP (Local Control Panel) | 9 | Relay 2 (04, 05, 06) |
| 2 | RS-485 serial bus connector | 10 | Lifting ring |
| 3 | Digital I/O and 24 V power supply | 11 | Mounting slot |
| 4 | Analog I/O connector | 12 | Cable clamp (PE) |
| 5 | USB connector | 13 | Earth (ground) |
| 6 | Serial bus terminal switch | 14 | Motor output terminals 96 (U), 97 (V), 98 (W) |
| 7 | Analog switches (A53), (A54) | 15 | Mains input terminals 91 (L1), 92 (L2), 93 (L3) |
| 8 | Relay 1 (01, 02, 03) | 16 | TB5 (IP21 only). Terminal block for anti-condensation heater |

Table 1.1 Legend to *Illustration 1.1* and *Illustration 1.2*

1.2 Purpose of the Manual

This manual provides detailed information for the installation and start up of the frequency converter.

Chapter 3 Installation provides requirements for mechanical and electrical installation, including:

- Input
- Motor
- Control wiring
- Serial communications wiring
- Control terminal functions

VLT® is a registered trademark.

1.3 Product Overview

A frequency converter is an electronic motor controller that converts DC into a variable AC waveform output. The frequency and voltage of the output are regulated to control the motor speed or torque. The frequency converter can vary the speed of the motor in response to remote commands from external controllers.

The frequency converter offers many control, monitoring and efficiency functions such as

- monitoring the system and motor status
- Issuing warnings or alarms for fault conditions
- starting and stopping the motor
- optimising energy efficiency

Operation and monitoring functions are available as status indications to an outside control system or serial communication network.

1.4 Internal Controller Functions

Illustration 1.3 is a block diagram of the frequency converter's internal components.

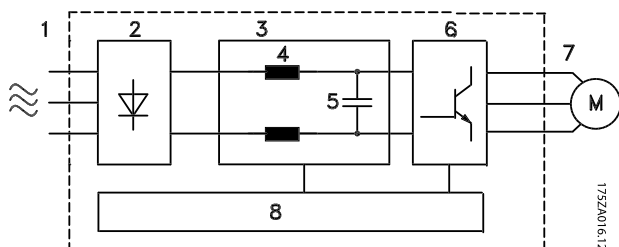

Illustration 1.3 Frequency Converter Block Diagram

| Area | Title | Functions |
|------|-------------------|--|
| 1 | Mains input | <ul style="list-style-type: none"> • 3-phase AC mains supply to the frequency converter |
| 2 | Rectifier | <ul style="list-style-type: none"> • The rectifier bridge converts the AC input to DC current to supply inverter power. |
| 3 | DC-bus | <ul style="list-style-type: none"> • Intermediate DC-bus circuit handles the DC current. |
| 4 | DC reactors | <ul style="list-style-type: none"> • Filter the intermediate DC circuit voltage. • Provide line transient protection. • Reduce RMS current. • Raise the power factor reflected back to the line. • Reduce harmonics on the AC input. |
| 5 | Capacitor bank | <ul style="list-style-type: none"> • Stores the DC power. • Provides ride-through protection for short power losses. |
| 6 | Inverter | <ul style="list-style-type: none"> • Converts the DC into a controlled PWM AC waveform for a controlled variable output to the motor. |
| 7 | Output to motor | <ul style="list-style-type: none"> • Regulated 3-phase output power to the motor |
| 8 | Control circuitry | <ul style="list-style-type: none"> • Input power, internal processing, output, and motor current are monitored to provide efficient operation and control. • User interface and external commands are monitored and performed. • Status output and control can be provided. |

Table 1.2 Legend to Illustration 1.3

2 Safety

2.1 Safety Symbols

⚠ WARNING

HIGH VOLTAGE

Frequency converters contain high voltage when connected to AC mains input power. Qualified personnel only should perform installation, start up, and maintenance. Failure to perform installation, start up, and maintenance by qualified personnel could result in death or serious injury.

⚠ WARNING

UNINTENDED START

When the frequency converter is connected to AC mains, the motor may start at any time. The frequency converter, motor, and any driven equipment must be in operational readiness. Failure to be in operational readiness when the frequency converter is connected to AC mains could result in death, serious injury, equipment, or property damage.

⚠ WARNING

DISCHARGE TIME

Frequency converters contain DC-link capacitors that can remain charged even when the frequency converter is not powered. To avoid electrical hazards, disconnect AC mains, any permanent magnet type motors, and any remote DC-link power supplies, including battery back-ups, UPS, and DC-link connections to other frequency converters. Wait for the capacitors to fully discharge before performing any service or repair work. The amount of wait time is listed in the *Discharge Time* table. Failure to wait the specified time after power has been removed before doing service or repair could result in death or serious injury.

| Voltage [V] | Power range [kW] | Minimum waiting time (minutes) |
|-------------|------------------|--------------------------------|
| 3x400 | 110-315 | 20 |
| 3x460 | 110-315 | 20 |
| 3x575 | 110-315 | 20 |

Table 2.1 Discharge Time



Table 2.2 Approvals

The frequency converter complies with UL508C thermal memory retention requirements. For more information, refer to the section *Motor Thermal Protection* in the product specific *design guide*.

NOTICE

Imposed limitations on the output frequency (due to export control regulations):

From software version 6.72 onwards, the output frequency of the frequency converter is limited to 590 Hz. Software versions 6x.xx also limit the maximum output frequency to 590 Hz, but these versions cannot be flashed, that is, neither downgraded nor upgraded.

3 Installation

3.1 Planning the Installation Site

3

NOTICE

Before performing the installation it is important to plan the installation of the frequency converter. Neglecting this may result in extra work during and after installation.

Select the best possible operation site by considering the following (see details on the following pages and the respective Design Guides):

- Ambient operating temperature
- Installation method
- How to cool the unit
- Position of the frequency converter
- Cable routing
- Ensure the power source supplies the correct voltage and necessary current
- Ensure that the motor current rating is within the maximum current from the frequency converter
- If the frequency converter is without built-in fuses, ensure that the external fuses are rated correctly

| Voltage [V] | Altitude restrictions |
|-------------|--|
| 380-500 | At altitudes above 3,000 m, contact Danfoss regarding PELV |
| 525-690 | At altitudes above 2,000 m, contact Danfoss regarding PELV |

Table 3.1 Installation in High Altitudes

3.2 Pre-Installation Check List

- Before unpacking the frequency converter, ensure the packaging is intact. If any damage has occurred, immediately contact the shipping company to claim the damage.
- Before unpacking the frequency converter, locate it as close as possible to the final installation site
- Compare the model number on the nameplate to what was ordered to verify the proper equipment
- Ensure each of the following are rated for the same voltage:
 - Mains (power)
 - Frequency converter
 - Motor

- Ensure that frequency converter output current rating is equal to or greater than motor full load current for peak motor performance
 - Motor size and frequency converter power must match for proper overload protection

3.3 Mechanical Installation

3.3.1 Cooling

- Top and bottom clearance for air cooling must be provided. Generally, 225 mm (9 in) is required.
- Improper mounting can result in over heating and reduced performance

NOTICE

A door fan(s) is required on the enclosure to remove the heat not contained in the backchannel of the frequency converters and any additional losses generated by other components inside the enclosure. The total required air flow must be calculated so that the appropriate fans can be selected.

Airflow

The necessary airflow over the heat sink must be secured. The flow rate is shown in Table 3.2.

| Frame | Door fan/top fan | Heat sink fan |
|-------|----------------------------------|----------------------------------|
| D1h | 102 m ³ /hr (60 CFM) | 420 m ³ /hr (250 CFM) |
| D2h | 204 m ³ /hr (120 CFM) | 840 m ³ /hr (500 CFM) |

Table 3.2 Airflow

3.3.1.1 Refrigerant Cooling

The Danfoss Turbocor frequency converters are equipped with refrigerant cooling.

The refrigerant inlet is on the top of the frequency converter to the left.

The refrigerant outlet is on the top of the frequency converters to the right.

| | |
|----------------------------|---------------------------------------|
| Dimensions | 3/8 inch OD X 0.049 inch wall thk |
| Material | COPPER ALLOY 122, ASTM B-75, annealed |
| Nominal operating pressure | 10 bar/145 psi |
| Maximum working pressure | 12 bar/174 psi |

Table 3.3 Tubing Specifications

⚠ WARNING**CONDENSATION**

Condensation must not be allowed to form on the inside of the frequency converter. The flow of refrigerant must be controlled in a way that ensures that the temperature of the internal heatsink stays above the dew point. Failure to control condensation will result in damage to the frequency converter.

3.3.2 Lifting

⚠ WARNING**RISK OF INJURY OR DEATH**

The lifting bar must be able to handle the weight of the frequency converter to ensure that it will not break during lifting.

- See *chapter 5.1 Power-dependent Specifications* for the weight of the different enclosure types.
- Maximum diameter for bar is 2.5 cm (1 inch).
- The angle from the top of the frequency converter to the lifting cable should be 60° or greater.

Failure to follow recommendations could result in death or serious injury.

3.3.3 Wall Mounting - IP21 (NEMA 1) Units

Consider the following before selecting the final installation site:

- Free space for cooling
- Access to open the door
- Cable entry from the bottom

3.4 Electrical Installation

3.4.1 General Requirements

This section contains detailed instructions for wiring the frequency converter. The following tasks are described:

- Wiring the motor to the frequency converter output terminals
- Wiring the AC mains to the frequency converter input terminals
- Connecting control and serial communication wiring
- After power has been applied, checking input and motor power

⚠ WARNING**EQUIPMENT HAZARD!**

Rotating shafts and electrical equipment can be hazardous. All electrical work must conform to national and local electrical codes. It is strongly recommended that installation, start up, and maintenance be performed only by trained and qualified personnel. Failure to follow these guidelines could result in death or serious injury.

⚠ CAUTION**WIRING ISOLATION!**

Run input power, motor wiring and control wiring in three separate metallic conduits or use separated shielded cable for high frequency noise isolation. Failure to isolate power, motor and control wiring could result in less than optimum frequency converter and associated equipment performance.

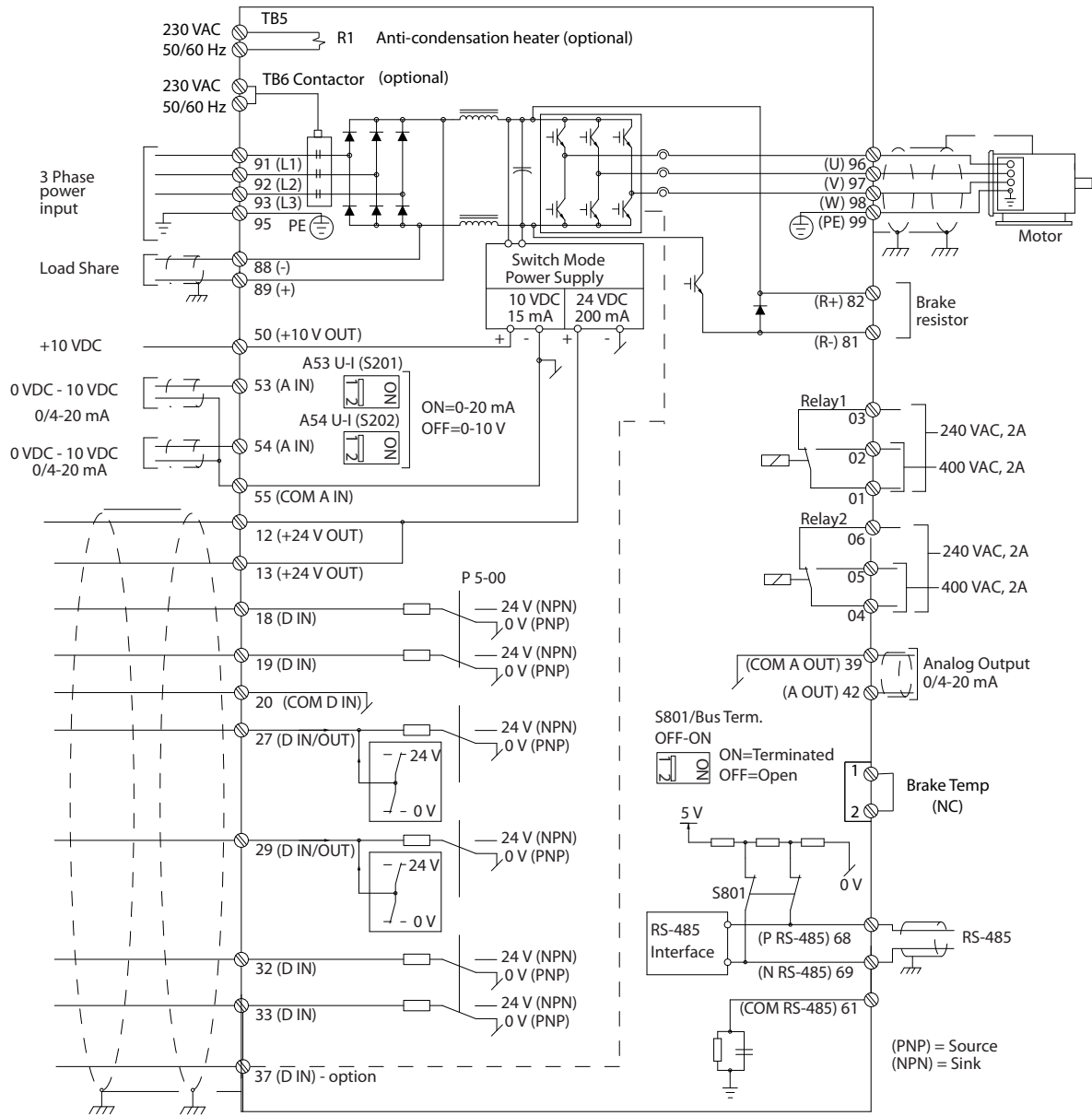

Illustration 3.1 Interconnect Diagram

For safety, comply with the following requirements

- Electronic controls equipment is connected to hazardous mains voltage. Extreme care should be taken to protect against electrical hazards when applying power to the unit.
- Run motor cables from multiple frequency converters separately. Induced voltage from output motor cables run together can charge equipment capacitors even with the equipment turned off and locked out.
- Field wiring terminals are not intended to receive a conductor one size larger.

Overload and equipment protection

- An electronically activated function within the frequency converter provides overload protection for the motor. The overload calculates the level of increase to activate timing for the trip (controller output stop) function. The higher the current draw, the quicker the trip response. The overload provides Class 20 motor protection.
- Because the motor wiring carries high frequency current, it is important that wiring for mains, motor power, and control are run separately. Use metallic conduit or separated shielded wire. See *Illustration 3.2*. Failure to isolate power, motor, and control wiring could result in less than optimum equipment performance.

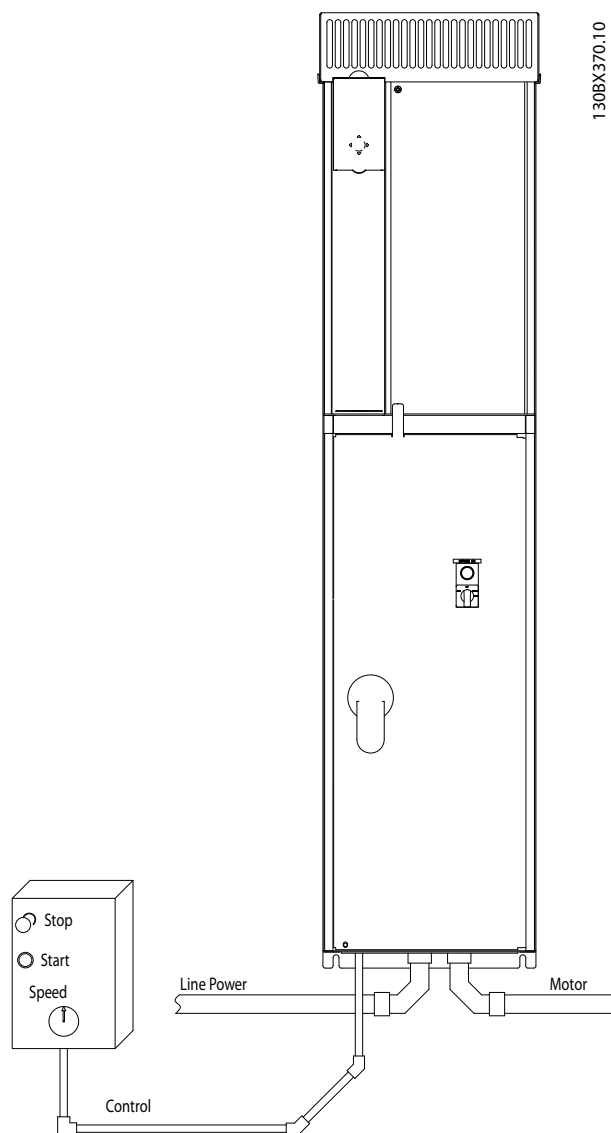
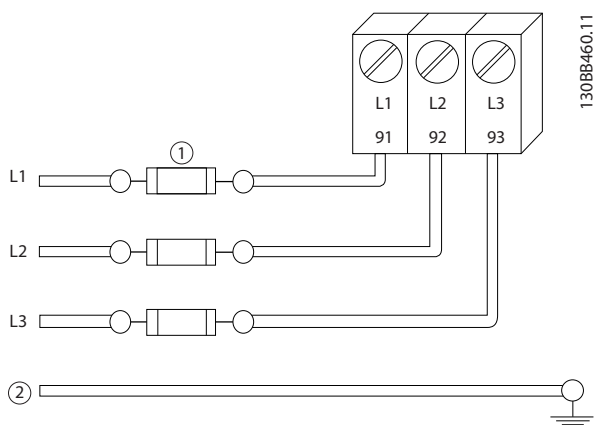

Illustration 3.2 Example of Proper Electrical Installation Using Conduit



| | |
|---|--------|
| 1 | Fuses |
| 2 | Ground |

Illustration 3.3 Frequency Converter Fuses

Wire Type and Ratings

- All wiring must comply with local and national regulations regarding cross-section and ambient temperature requirements.
- Danfoss recommends that all power connections be made with a minimum 75 °C rated copper wire.

3.4.2 Grounding Requirements

⚠ WARNING

GROUNDING HAZARD!

For operator safety, it is important to ground the frequency converter properly in accordance with national and local electrical codes as well as instructions contained within this document. Do not use conduit connected to the frequency converter as a replacement for proper grounding. Ground currents are higher than 3.5 mA. Failure to ground the frequency converter properly could result in death or serious injury.

NOTICE

It is the responsibility of the user or certified electrical installer to ensure correct grounding of the equipment in accordance with national and local electrical codes and standards.

- Follow all local and national electrical codes to ground electrical equipment properly
- Proper protective earthing for equipment with ground currents higher than 3.5 mA must be established, see *chapter 3.4.2.1 Leakage Current (>3.5 mA)*

- A dedicated ground wire is required for input power, motor power and control wiring
- Use the clamps provided with the equipment for proper ground connections
- Do not ground one frequency converter to another in a “daisy chain” fashion
- Keep the ground wire connections as short as possible
- Using high-strand wire to reduce electrical noise is recommended
- Follow motor manufacturer wiring requirements

3.4.2.1 Leakage Current (>3.5 mA)

Follow national and local codes regarding protective earthing of equipment with a leakage current >3.5 mA. Frequency converter technology implies high frequency switching at high power. This will generate a leakage current in the earth connection. A fault current in the frequency converter at the output power terminals might contain a DC component, which can charge the filter capacitors and cause a transient earth current. The earth leakage current depends on various system configurations including RFI filtering, screened motor cables, and frequency converter power.

EN/IEC61800-5-1 (Power Drive System Product Standard) requires special care if the leakage current exceeds 3.5 mA. Earthing (grounding) must be reinforced in one of the following ways:

- Earth (ground) wire of at least 10 mm²
- Two separate earth (ground) wires both complying with the dimensioning rules

See EN 60364-5-54 § 543.7 for further information.

3.4.2.2 Grounding IP21 Enclosures

The frequency converter can be grounded using conduit or shielded cable. For grounding of the power connections, use the dedicated grounding points as shown in *Illustration 3.4*.

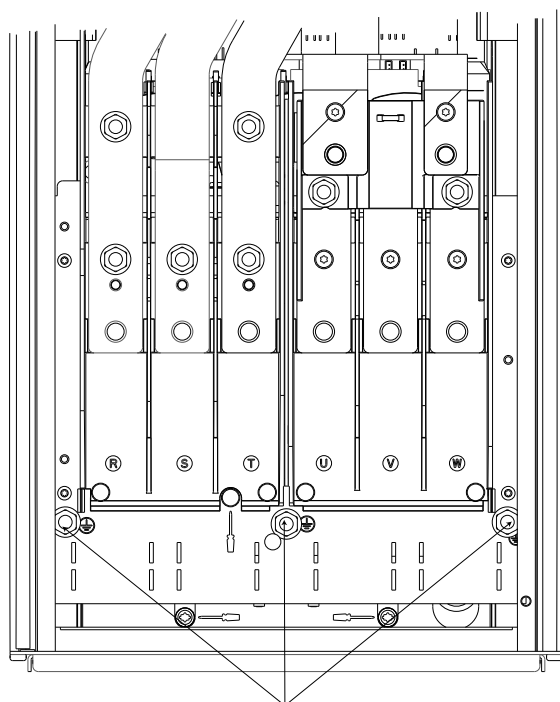

Illustration 3.4 Grounding for IP21 Enclosures.

3.4.3 Motor Connection

WARNING

INDUCED VOLTAGE!

Run output motor cables from multiple frequency converters separately. Induced voltage from output motor cables run together can charge equipment capacitors even with the equipment turned off and locked out. Failure to run output motor cables separately could result in death or serious injury.

- For maximum cable sizes, see *chapter 5.1 Power-dependent Specifications*
- Comply with local and national electrical codes for cable sizes
- Gland plates are provided at the base of IP21 units
- Do not install power factor correction capacitors between the frequency converter and the motor
- Do not wire a starting or pole-changing device between the frequency converter and the motor
- Connect the 3-phase motor wiring to terminals 96 (U), 97 (V), and 98 (W)
- Earth (ground) the cable in accordance with the instructions provided
- Torque terminals in accordance with the information provided in *chapter 5.3.4 Connection Tightening Torques*
- Follow motor manufacturer wiring requirements

3.4.3.1 Terminal Locations

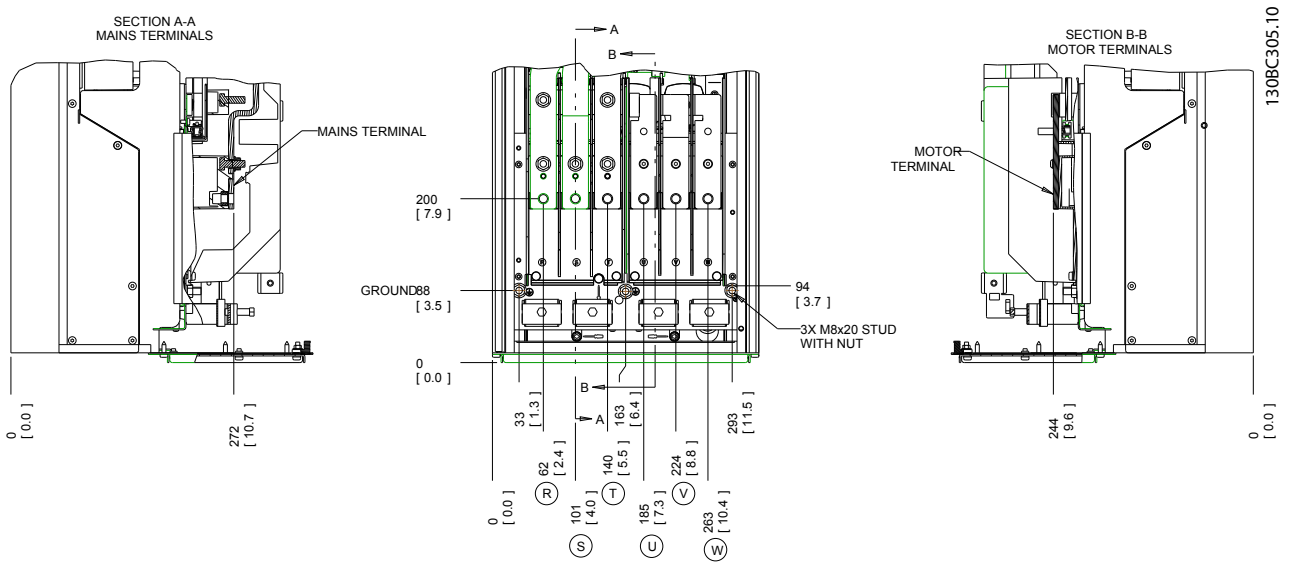

Illustration 3.5 Terminal Locations D1h

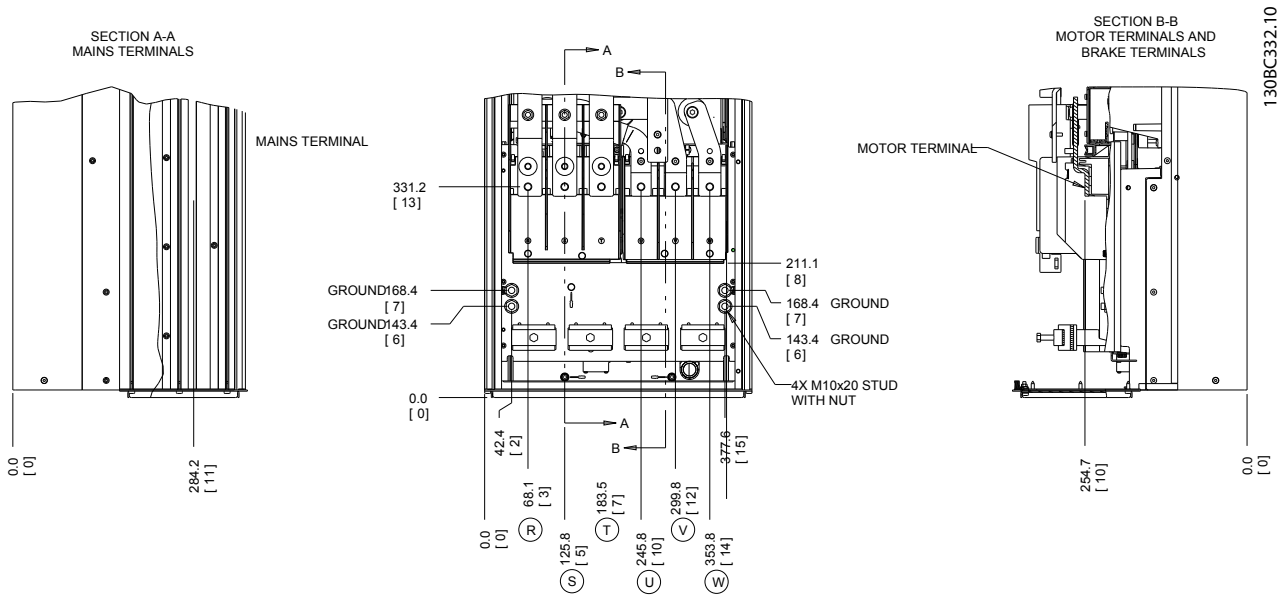

Illustration 3.6 Terminal Locations D2h

3.4.4 Motor Cable

The motor must be connected to terminals U/T1/96, V/T2/97, W/T3/98. Earth (ground) to terminal 99. The factory setting is for clockwise rotation with the frequency converter output connected as follows:

| Terminal number | Function |
|-----------------|------------------------|
| 96, 97, 98, | Mains U/T1, V/T2, W/T3 |
| 99 | Earth (ground) |

Table 3.4 Terminals for Motor Cable Connection

3.4.5 Motor Rotation Check

The direction of rotation can be changed by switching 2 phases in the motor cable.

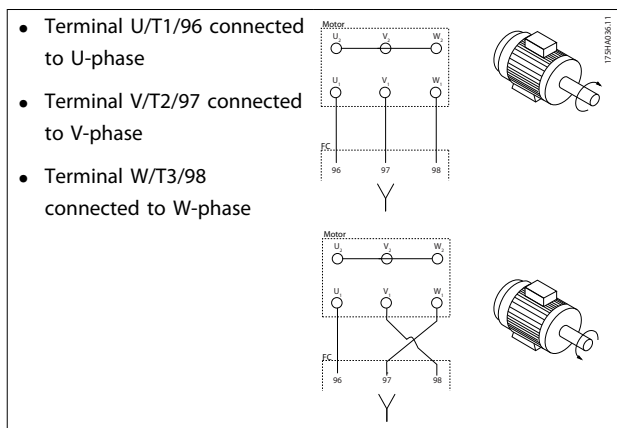
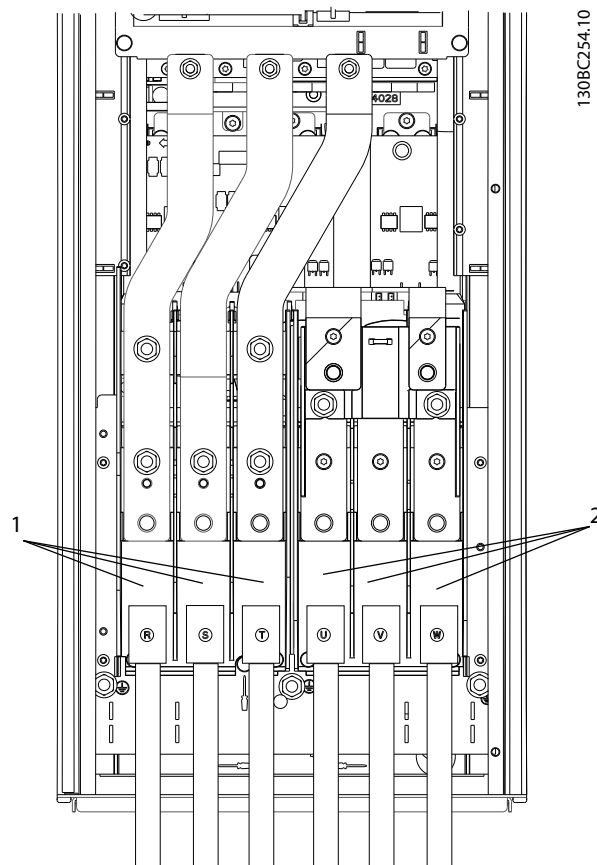

Table 3.5 Wiring for Changing Motor Direction

3.4.6 AC Mains Connection

- All frequency converters may be used with an isolated input source as well as with ground reference power lines. When supplied from an isolated mains source (IT mains or floating delta) or TT/TN-S mains with a grounded leg (grounded delta), set 14-50 RFI Filter to [0] Off. When off, the internal RFI filter capacitors between the chassis and the intermediate circuit are isolated. Isolating the capacitors prevents damage to the intermediate circuit and reduces ground capacity currents in accordance with IEC 61800-3.
- Size wiring is based upon the input current of the frequency converter.
- Comply with local and national electrical codes for cable sizes.

1. Ground the cable in accordance with the instructions provided.
2. Connect 3-phase AC input power wiring to terminals L1, L2, and L3 (see Illustration 3.7).



130BC254.10

3

| | |
|---|------------------|
| 1 | Mains connection |
| 2 | Motor connection |

Illustration 3.7 Connecting to AC Mains

3.4.7 DC-Link Connection

Two field terminals are provided for connecting to the DC-Link. The terminals are marked "+REGEN82" and "-REGEN83".

WARNING

REGEN TERMINALS

Frequency converters contain high voltage The REGEN terminals must be connected to the correct polarity and properly insulated from ground. Qualified personnel only should perform installation, start up, and maintenance. Failure to perform installation, start up, and maintenance by qualified personnel could result in death or serious injury.

⚠ WARNING

HIGH VOLTAGE

The DC-link of a frequency converter contains high voltage when connected to AC mains input power. Qualified personnel only should perform installation, start-up, and maintenance. Failure to perform installation, start-up, and maintenance by qualified personnel could result in death or serious injury.

⚠ WARNING

DISCHARGE TIME

Frequency converters contain DC-link capacitors that can remain charged even when the frequency converter is not powered. To avoid electrical hazards, disconnect AC mains, any permanent magnet type motors, and any remote DC-link power supplies, including battery back-ups, UPS, and DC-link connections to other frequency converters. Wait for the capacitors to fully discharge before performing any service or repair work. The amount of wait time is listed in *Table 2.1*. Failure to wait the specified time after power has been removed before doing service or repair could result in death or serious injury.

3.5 Control Wiring Connection

- Isolate control wiring from high power components in the frequency converter

3.5.1 Access

All terminals to the control cables are located on the inside of the frequency converter. To access, open the door (IP21).

3.5.2 Using Screened Control Cables

Danfoss recommends braided screened/armoured cables to optimise EMC immunity of the control cables and the EMC emission from the motor cables.

The ability of a cable to reduce the incoming and outgoing radiation of electric noise depends on the transfer impedance (Z_T). The screen of a cable is normally designed to reduce the transfer of electric noise; however, a screen with a lower transfer impedance (Z_T) value is more effective than a screen with a higher transfer impedance (Z_T).

Transfer impedance (Z_T) is rarely stated by cable manufacturers, but it is often possible to estimate transfer impedance (Z_T) by assessing the physical design of the cable.

Transfer impedance (Z_T) can be assessed on the basis of the following factors:

- The conductivity of the screen material.
- The contact resistance between the individual screen conductors.
- The screen coverage, i.e. the physical area of the cable covered by the screen - often stated as a percentage value.
- Screen type, i.e. braided or twisted pattern.

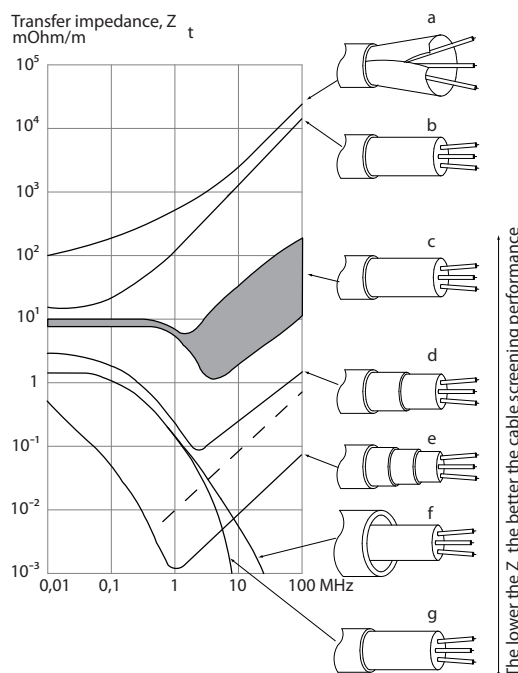

175ZA166.13

| | |
|---|---|
| a | Aluminium-clad with copper wire |
| b | Twisted copper wire or armoured steel wire cable |
| c | Single-layer braided copper wire with varying percentage screen coverage (this is the typical Danfoss reference cable). |
| d | Double-layer braided copper wire |
| e | Twin layer of braided copper wire with a magnetic, screened/armoured intermediate layer |
| f | Cable that runs in copper tube or steel tube |
| g | Lead cable with 1.1 mm wall thickness |

Illustration 3.8 Cable Screening Performance

3.5.3 Grounding of Screened Control Cables

Correct screening

The preferred method in most cases is to secure control and serial communication cables with screening clamps provided at both ends to ensure best possible high frequency cable contact. If the ground potential between the frequency converter and the PLC is different, electric noise may occur that disturbs the entire system. Solve this

problem by fitting an equalizing cable next to the control cable. Minimum cable cross section: 16 mm².

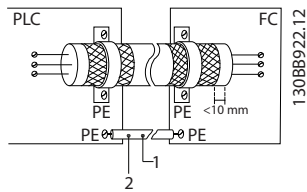

| | |
|---|-------------------------|
| 1 | Min. 16 mm ² |
| 2 | Equalizing cable |

Illustration 3.9 Correct Screening

50/60 Hz ground loops

With very long control cables, ground loops may occur. To eliminate ground loops, connect one end of the screen-to-ground with a 100 nF capacitor (keeping leads short).

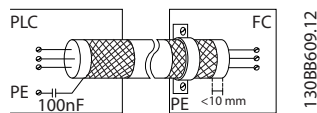
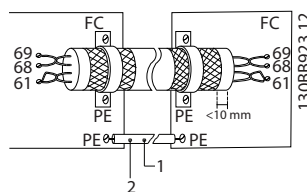

Illustration 3.10 Avoiding Ground Loops

Avoid EMC noise on serial communication

This terminal is connected to ground via an internal RC link. Use twisted-pair cables to reduce interference between conductors. The recommended method is shown below:



| | |
|---|-------------------------|
| 1 | Min. 16 mm ² |
| 2 | Equalizing cable |

Illustration 3.11 Avoiding EMC Noise

Alternatively, the connection to terminal 61 can be omitted:

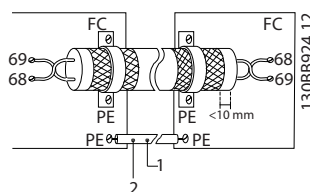

| | |
|---|-------------------------|
| 1 | Min. 16 mm ² |
| 2 | Equalizing cable |

Illustration 3.12 Screening without Using Terminal 61

3.5.4 Control Terminal Types

3

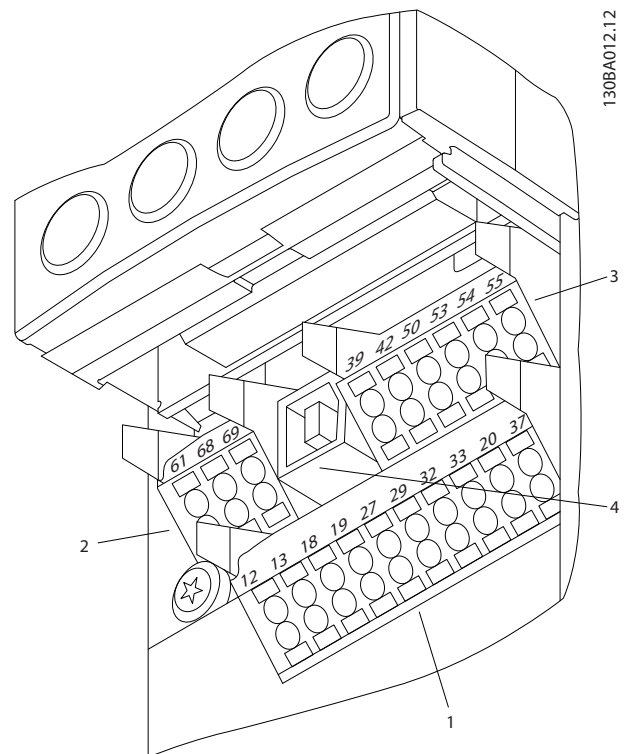

Illustration 3.13 Control Terminal Locations

- **Connector 1** provides four programmable digital input terminals, two additional digital terminals programmable as either input or output, a 24 V DC terminal supply voltage, and a common for optional customer supplied 24 V DC voltage
- **Connector 2** terminals (+)68 and (-)69 are for an RS485 serial communications connection
- **Connector 3** provides 2 analog inputs, one analog output, 10 V DC supply voltage, and commons for the inputs and output
- **Connector 4** is a USB port available for use with the MCT 10 Set-up Software
- Also provided are 2 Form C relay outputs that are located on the power card

3

3.5.5 Wiring to Control Terminals

Terminal plugs can be removed for easy access.

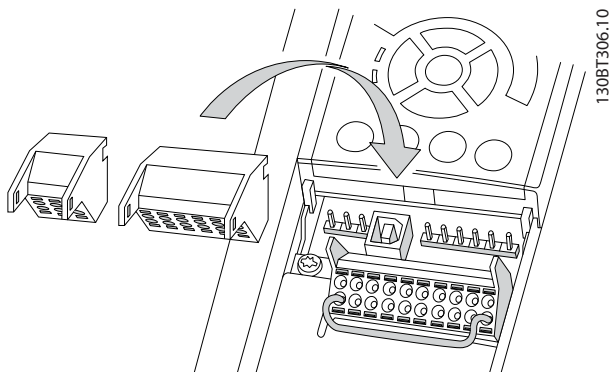

Illustration 3.14 Removal of Control Terminals

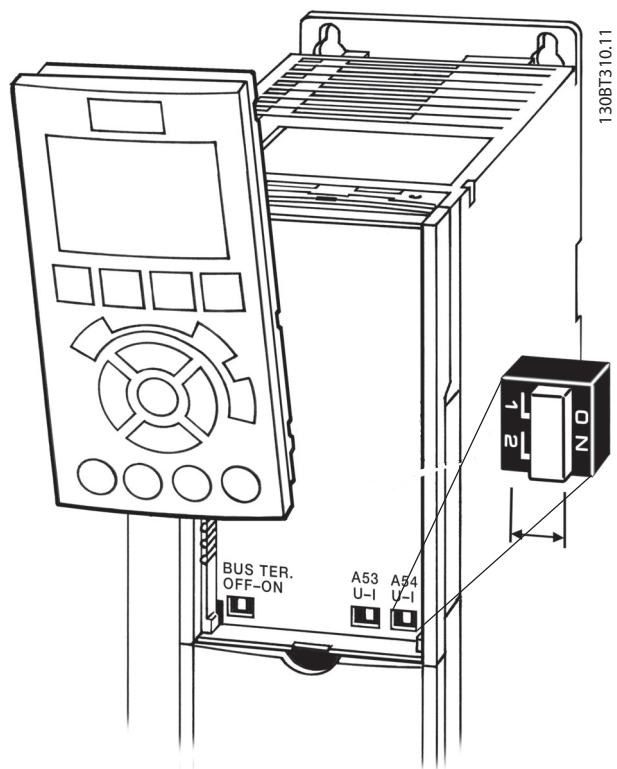

Illustration 3.15 Location of Bus Termination Switch

To run STO, additional wiring for the frequency converter is required. Refer to *VLT® Frequency Converters Safe Torque Off Operating Instructions* for further information.

3.6 Serial Communication

RS485 is a two-wire bus interface compatible with multi-drop network topology.

Terminate each segment at both ends, using the termination switch (S801) of the frequency converter. Always use screened twisted pair (STP) cable for bus cabling, and always follow good common installation practice.

Low-impedance earth (ground) connection of the screen at every node is important, including at high frequencies. Thus, connect a large surface of the screen to earth (ground), for example with a cable clamp or a conductive cable gland. It may be necessary to apply potential-equalizing cables to maintain the same earth (ground) potential throughout the network. Particularly in installations with long cables.

| | |
|-------------------|---|
| Cable | Screened twisted pair (STP) |
| Impedance | 120 Ω |
| Max. cable length | 1200 m (including drop lines) 500 m station-to-station |

Table 3.6

4 Start Up and Commissioning

4.1 Pre-start

⚠ CAUTION

Before applying power to the unit, inspect the entire installation as detailed in *Table 4.1*. Check mark those items when completed.

| Inspect for | Description | <input checked="" type="checkbox"/> |
|-------------------------------|---|-------------------------------------|
| Auxiliary equipment | <ul style="list-style-type: none"> Look for auxiliary equipment, switches, disconnects, or input fuses/circuit breakers on the input power side of the frequency converter or output side to the motor. Ensure that they are ready for full speed operation. Check function and installation of any sensors used for feedback to the frequency converter. Remove power factor correction caps on motors, if present. | |
| Cable routing | <ul style="list-style-type: none"> Use separate metallic conduits for each of the following: <ul style="list-style-type: none"> Input power Motor wiring Control wiring | |
| Control wiring | <ul style="list-style-type: none"> Check for broken or damaged wires and loose connections. Check that control wiring is isolated from power and motor wiring for noise immunity. Check the voltage source of the signals, if necessary. Use shielded or twisted pair cable. Ensure that the shield is terminated correctly. | |
| Cooling clearance | <ul style="list-style-type: none"> Measure that top and bottom clearance is adequate to ensure proper air flow for cooling. | |
| EMC considerations | <ul style="list-style-type: none"> Check for proper installation regarding electromagnetic compatibility. | |
| Environmental considerations | <ul style="list-style-type: none"> See equipment label for the maximum ambient operating temperature limits. Humidity levels must be 5–95%, non-condensing. | |
| Fusing and circuit breakers | <ul style="list-style-type: none"> Check for proper fusing or circuit breakers. Check that all fuses are inserted firmly and in operational condition and that all circuit breakers are in the open position. | |
| Grounding | <ul style="list-style-type: none"> The unit requires a ground wire from its chassis to the building ground. Check for good ground connections that are tight and free of oxidation. Grounding to conduit or mounting the back panel to a metal surface is not sufficient. | |
| Input and output power wiring | <ul style="list-style-type: none"> Check for loose connections. Check that motor and mains are in separate conduit or separated screened cables. | |
| Panel interior | <ul style="list-style-type: none"> Inspect that the unit interior is free of debris and corrosion. | |
| Switches | <ul style="list-style-type: none"> Ensure that all switch and disconnect settings are in the proper positions. | |
| Vibration | <ul style="list-style-type: none"> Check that the unit is mounted solidly or that shock mounts are used, as necessary. Check for an unusual amount of vibration. | |

Table 4.1 Start-up Checklist

4.2 Applying Power

⚠ WARNING

HIGH VOLTAGE!

Frequency converters contain high voltage when connected to the energised DC bus. Only qualified personnel should install, start up and maintain the frequency converters. Failure to let qualified personnel install, start up and maintain the frequency converters could result in death or serious injury.

⚠ WARNING

UNINTENDED START!

When the frequency converter is connected to the energised DC bus, the motor may start at any time. The frequency converter, motor, and any driven equipment must be in operational readiness. Failure to be in operational readiness when the frequency converter is connected to the energised DC bus could result in death, serious injury, equipment, or property damage.

1. Confirm input voltage is balanced within 3%. If not, correct input voltage imbalance before proceeding. Repeat procedure after voltage correction.
2. Ensure optional equipment wiring, if present, matches installation application.
3. Ensure that all operator devices are in the OFF position. Panel doors closed, or a cover mounted.
4. Apply power to the unit. DO NOT start the frequency converter now. For units with a disconnect switch, turn to the ON position to apply power to the frequency converter.

5 Specifications

5.1 Power-dependent Specifications

| DTC 302 | N165 | N232 | N262 |
|--|------------------|-------------------|-------------------|
| Typical shaft output at 400 V [kW] | 165 | 232 | 262 |
| Typical shaft output at 460 V [hp] | 221 | 311 | 352 |
| Enclosure IP21 | D1h | D2h | D2h |
| Output current | | | |
| Continuous (at 400 V) [A] | 318 | 424 | 480 |
| Continuous (at 460 V) [A] | 263 | 350 | 443 |
| Continuous kVA (at 400 V) [kVA] | 179 | 252 | 285 |
| Continuous kVA (at 460 V) [kVA] | 179 | 252 | 285 |
| Max. input current | | | |
| Continuous (at 400 V) [A] | 271 | 380 | 430 |
| Continuous (at 460 V) [A] | 235 | 330 | 374 |
| Max. cable size: mains, motor, mm (AWG) | 2x95 (2x3/0 mcm) | 2x185 (2x350 mcm) | 2x185 (2x350 mcm) |
| Max. external mains fuses [A] | 400 | 550 | 630 |
| Estimated power loss at 400 V [W] | 4271 | 5232 | 6203 |
| Estimated power loss at 460 V [W] | 3561 | 4390 | 5830 |
| Efficiency | 0.98 | | |
| Output frequency [Hz] | 0–590 | | |
| Heat sink overtemperature trip [°F] ([°C]) | 230 (110) | | |
| Control card ambient trip [°F] ([°C]) | 158 (70) | 149 (65) | 149 (65) |

5

Table 5.1 Mains Supply 3x380-500 V AC

| DTC 302 | N165 | N232 |
|--|--------------|---------------|
| Typical shaft output at 575 V [kW] | 165 | 232 |
| Typical shaft output at 575 V [hp] | 221 | 311 |
| Enclosure IP21 | D1h | D2h |
| Output current | | |
| Continuous (at 575 V) [A] | 205 | 286 |
| Continuous kVA (at 575 V) [kVA] | 179 | 252 |
| Max. input current | | |
| Continuous (at 575 V) [A] | 188 | 264 |
| Max. cable size: mains, motor, mm (AWG) | 2x95 (2x3/0) | 2x185 (2x350) |
| Max. external mains fuses [A] | 315 | 550 |
| Estimated power loss at 575 V [W] | 3873 | 5288 |
| Weight, enclosure IP21 kg (lbs.) | 62 (135) | 125 (275) |
| Efficiency | 0.98 | |
| Output frequency [Hz] | 0–590 | |
| Heat sink overtemperature trip [°F] ([°C]) | 230 (110) | |
| Control card ambient trip [°F] ([°C]) | 167 (75) | 176 (80) |

Table 5.2 Mains Supply 3x575 V AC

- The typical power loss is at nominal load conditions and expected to be within $\pm 15\%$ (tolerance relates to variety in voltage and cable conditions).
- The losses are based on the default switching frequency. The losses increase significantly at higher switching frequencies.

5.2 General Technical Data

Mains supply (L1, L2, L3)

| | |
|----------------|--------------------------------------|
| Supply voltage | 380-500 V \pm 10%, 575 V \pm 10% |
|----------------|--------------------------------------|

Mains voltage low/mains voltage drop-out:

During low mains voltage or a mains drop-out, the frequency converters continues until the intermediate circuit voltage drops below the minimum stop level, which corresponds typically to 15% below the frequency converter's lowest rated supply voltage. Power-up and full torque cannot be expected at mains voltage lower than 10% below the frequency converter's lowest rated supply voltage.

| | |
|------------------|-------------------|
| Supply frequency | 50/60 Hz \pm 5% |
|------------------|-------------------|

| | |
|---|------------------------------|
| Max. imbalance temporary between mains phases | 3.0% of rated supply voltage |
|---|------------------------------|

| | |
|---------------------------------|----------------------------------|
| True Power Factor (λ) | \geq 0.9 nominal at rated load |
|---------------------------------|----------------------------------|

| | |
|--|---------|
| Displacement Power Factor ($\cos \Phi$) near unity | (>0.98) |
|--|---------|

| | |
|--|----------------------------|
| Switching on input supply L1, L2, L3 (power ups) | maximum one time/2 minutes |
|--|----------------------------|

| | |
|------------------------------------|---|
| Environment according to EN60664-1 | overvoltage category III/pollution degree 2 |
|------------------------------------|---|

The unit is suitable for use on a circuit capable of delivering not more than 100,000 RMS symmetrical Amperes, 480/600 V

Motor Output (U, V, W)

| | |
|----------------|--------------------------|
| Output voltage | 0-100% of supply voltage |
|----------------|--------------------------|

| | |
|------------------|-----------|
| Output frequency | 0-590 Hz* |
|------------------|-----------|

| | |
|---------------------|-----------|
| Switching on output | Unlimited |
|---------------------|-----------|

| | |
|------------|-------------|
| Ramp times | 0.01-3600 s |
|------------|-------------|

* Dependent on voltage and power

Cable lengths and cross sections

| | |
|--|-------|
| Max. motor cable length, screened/armoured | 150 m |
|--|-------|

| | |
|--|-------|
| Max. motor cable length, unscreened/unarmoured | 300 m |
|--|-------|

| | |
|-------------------------------------|--|
| Max. cross section to motor, mains* | |
|-------------------------------------|--|

| | |
|--|---|
| Maximum cross section to control terminals, rigid wire | 1.5 mm ² /16 AWG (2x0.75 mm ²) |
|--|---|

| | |
|--|---------------------------|
| Maximum cross section to control terminals, flexible cable | 1 mm ² /18 AWG |
|--|---------------------------|

| | |
|--|-----------------------------|
| Maximum cross section to control terminals, cable with enclosed core | 0.5 mm ² /20 AWG |
|--|-----------------------------|

| | |
|--|----------------------|
| Minimum cross section to control terminals | 0.25 mm ² |
|--|----------------------|

Digital inputs

| | |
|-----------------------------|-------|
| Programmable digital inputs | 4 (6) |
|-----------------------------|-------|

| | |
|-----------------|--|
| Terminal number | 18, 19, 27 ¹⁾ , 29 ¹⁾ , 32, 33 |
|-----------------|--|

| | |
|-------|------------|
| Logic | PNP or NPN |
|-------|------------|

| | |
|---------------|-----------|
| Voltage level | 0-24 V DC |
|---------------|-----------|

| | |
|------------------------------|---------|
| Voltage level, logic '0' PNP | <5 V DC |
|------------------------------|---------|

| | |
|------------------------------|----------|
| Voltage level, logic '1' PNP | >10 V DC |
|------------------------------|----------|

| | |
|------------------------------|----------|
| Voltage level, logic '0' NPN | >19 V DC |
|------------------------------|----------|

| | |
|------------------------------|----------|
| Voltage level, logic '1' NPN | <14 V DC |
|------------------------------|----------|

| | |
|--------------------------|---------|
| Maximum voltage on input | 28 V DC |
|--------------------------|---------|

| | |
|-------------------------|----------------------|
| Input resistance, R_i | approx. 4 k Ω |
|-------------------------|----------------------|

All digital inputs are galvanically isolated from the supply voltage (PELV) and other high-voltage terminals.

1) Terminals 27 and 29 can also be programmed as output.

Control card, RS485 serial communication

| | |
|-----------------|----------------------------------|
| Terminal number | 68 (P,TX+, RX+), 69 (N,TX-, RX-) |
|-----------------|----------------------------------|

| | |
|--------------------|--------------------------------|
| Terminal number 61 | Common for terminals 68 and 69 |
|--------------------|--------------------------------|

The RS485 serial communication circuit is functionally seated from other central circuits and galvanically isolated from the supply voltage (PELV).

Control card, 24 V DC output

| | |
|-----------------|--------|
| Terminal number | 12, 13 |
| Max. load | 200 mA |

The 24 V DC supply is galvanically isolated from the supply voltage (PELV), but has the same potential as the analog and digital inputs and outputs.

Control characteristics

| | |
|---|--------------------------------------|
| Resolution of output frequency at 0-1000 Hz | ±0.003 Hz |
| System response time (terminals 18, 19, 27, 29, 32, 33) | ≤2 ms |
| Speed control range (open loop) | 1:100 of synchronous speed |
| Speed accuracy (open loop) | 30-4000 rpm: Maximum error of ±8 rpm |

All control characteristics are based on a 4-pole asynchronous motor

Surroundings

| | |
|--|--|
| Enclosure type D1h/D2h | IP21/Type 1 |
| Vibration test all enclosure types | 0.7 g |
| Relative humidity | 5%-95% (IEC 721-3-3; Class 3K3 (non-condensing) during operation |
| Aggressive environment (IEC 60068-2-43) H ₂ S test | class Kd |
| Test method according to IEC 60068-2-43 H ₂ S (10 days) | |
| Ambient temperature (at 60AVM switching mode) | |
| - at full continuous FC output current | max. 104 °F [40 °C] |
| Minimum ambient temperature during full-scale operation | 0 °C |
| Minimum ambient temperature at reduced performance | - 10 °C |
| Temperature during storage/transport | -25 to +65/70 °C |
| Maximum altitude above sea level without derating | 1,000 m |
| Maximum altitude above sea level with derating | 3,000 m |

1) For more information on derating see the Design Guide, section on Special Conditions.

| | |
|-------------------------|--|
| EMC standards, Emission | EN 61800-3, EN 61000-6-3/4, EN 55011, IEC 61800-3 EN 61800-3, EN 61000-6-1/2, |
| EMC standards, Immunity | EN 61000-4-2, EN 61000-4-3, EN 61000-4-4, EN 61000-4-5, EN 61000-4-6 |

See the Design Guide, section on Special Conditions.

Control card performance

| | |
|---------------|------|
| Scan interval | 5 ms |
|---------------|------|

Protection and Features

- Electronic thermal motor protection against overload.
- Temperature monitoring of the heat sink ensures that the frequency converter trips if the temperature reaches 95 °C ±5 °C. An overload temperature cannot be reset until the temperature of the heat sink is below 70 °C ±5 °C (Guideline - these temperatures may vary for different power sizes, enclosures etc.).
- The frequency converter is protected against short-circuits on motor terminals U, V, W.
- If a mains phase is missing, the frequency converter trips or issues a warning (depending on the load).
- Monitoring of the intermediate circuit voltage ensures that the frequency converter trips if the intermediate circuit voltage is too low or too high.
- The frequency converter is protected against earth (ground) faults on motor terminals U, V, W.

5.3 Fuse Tables

5.3.1 Protection

Branch circuit protection

In order to protect the installation against electrical and fire hazard, all branch circuits in an installation, switch gear, machines etc., must be short-circuited and over-current protected according to national/international regulations.

Short-circuit protection

The frequency converter must be protected against short-circuit to avoid electrical or fire hazard. Danfoss recommends using the fuses mentioned below to protect service personnel and equipment in case of an internal failure in the frequency converter. The frequency converter provides full short-circuit protection in case of a short-circuit on the motor output.

Over-current protection

Provide overload protection to avoid fire hazard due to overheating of the cables in the installation. The frequency converter is equipped with an internal over-current protection that can be used for upstream overload protection (UL-applications excluded). Moreover, fuses or circuit breakers can be used to provide the over-current protection in the installation. Over-current protection must always be carried out according to national regulations.

5.3.2 Fuse Selection

Danfoss recommends using the following fuses which ensures compliance with EN 50178. In case of malfunction, not following the recommendation may result in unnecessary damage to the frequency converter.

The fuses below are suitable for use on a circuit capable of delivering 100,000 Arms (symmetrical).

| | | |
|------------------|-----------|---------|
| N165, N232, N262 | 380–500 V | type aR |
| N165, N232 | 575 V | type aR |

Table 5.3 Recommended Fuses

| VLT Model | Bussman PN | Littelfuse PN | Littelfuse PN | Bussmann PN | Siba PN | Ferraz Shawmut PN | Ferraz Shawmut PN (Europe) | Ferraz Shawmut PN (North America) |
|-----------|------------|---------------|---------------|-------------|---------------|-------------------|----------------------------|-----------------------------------|
| N165 T5 | 170M2621 | LA50QS400-4 | L50S-400 | FWH-400A | 20 610 31.400 | A50QS400-4 | 6,9URD31D08A0400 | A070URD31KI0400 |
| N232 T5 | 170M4015 | LA50QS500-4 | L50S-500 | FWH-500A | 20 610 31.550 | A50QS500-4 | 6,9URD31D08A0550 | A070URD31KI0550 |
| N262 T5 | 170M4016 | LA50QS600-4 | L50S-600 | FWH-600A | 20 610 31.630 | A50QS600-4 | 6,9URD31D08A0630 | A070URD31KI0630 |

Table 5.4 Fuse Options for 380–500 V Frequency Converters

| VLT Model | Bussmann PN | Siba PN | Ferraz Shawmut European PN | Ferraz Shawmut North American PN |
|-----------|-------------|---------------|----------------------------|----------------------------------|
| N165 T7 | 170M2619 | 20 610 31.315 | 6,9URD31D08A0315 | A070URD31KI0315 |
| N232 T7 | 170M4015 | 20 620 31.550 | 6,9URD32D08A0550 | A070URD32KI0550 |

Table 5.5 Fuse Options for 575 V Frequency Converters

For UL compliance, use the Bussmann 170M series.

5.3.3 Short Circuit Current Rating (SCCR)

The Short Circuit Current Rating (SCCR) of the frequency converters is 100,000 amps at all voltages (380–575 V).

5.3.4 Connection Tightening Torques

When tightening all electrical connections it is very important to tighten with the correct torque. Too low or too high torque results in a bad electrical connection. Use a torque wrench to ensure correct torque. Always use a torque wrench to tighten the bolts.

| Frame size | Terminal | Torque [Nm (in-lbs)] | Bolt size |
|------------|---|----------------------|-----------|
| D1h | Mains Motor Load sharing Regen | 19-40 (168-354) | M10 |
| | Earth (Ground) Brake | 8.5-20.5 (75-181) | M8 |
| D2h | Mains Motor Regen Load sharing Earth (ground) | 19-40 (168-354) | M10 |
| | Brake | 8.5-20.5 (75-181) | M8 |

Table 5.6 Torque for Terminals

Index

A

AC input..... 4, 13
 AC mains..... 4, 5
 AC mains connection..... 13
 AC waveform..... 4
 Airflow..... 6
 Analog input..... 15
 Analog output..... 15

B

Block diagram..... 4

C

Cable length..... 20
 Check list, pre-installation..... 6
 Circuit breaker..... 17
 Conduit..... 9, 17
 Control cable..... 15
 Control cable, screened..... 15
 Control card performance..... 21
 Control card, 24 V DC output..... 21
 Control card, RS485 serial communication..... 20
 Control characteristic..... 21
 Control system..... 4
 Control terminal..... 16
 Control terminal type..... 15
 Control wiring..... 7, 9, 10, 17
 Control wiring connection..... 14
 Cooling clearance..... 17
 Cross section..... 20
 Current rating..... 6

D

DC current..... 4
 Derating..... 6, 21
 Digital input..... 15, 20
 Discharge time..... 5
 Disconnect switch..... 18

E

Electrical installation..... 7
 Electrical noise..... 10
 EMC..... 15, 17, 21
 Equalizing cable..... 15

External command..... 4
 External controller..... 4

F

Feedback..... 17
 Floating delta..... 13
 Frequency converter block diagram..... 4
 Full load current..... 6
 Functional testing..... 4
 Fuse..... 17
 Fusing..... 9, 17

G

Ground connection..... 10, 17
 Ground loop..... 15
 Ground wire..... 10, 17
 Grounded delta..... 13
 Grounding..... 10, 17
 Grounding hazard..... 10
 Grounding, IP21/54 enclosure..... 11
 Grounding, screened control cable..... 15

H

Harmonic..... 4

I

IEC 61800-3..... 21
 Induced voltage..... 9
 Input current..... 13
 Input power..... 4, 5, 7, 10, 17
 Input voltage..... 18
 Installation..... 4, 9, 17, 18
 Installation site..... 6
 Installation, electrical..... 7
 Installation, mechanical..... 6
 Isolated mains..... 13

L

Leakage current (>3.5 mA)..... 10

M

Mains..... 9
 Mains supply (L1, L2, L3)..... 20
 Mechanical installation..... 6
 Motor cable..... 9, 11, 13
 Motor connection..... 11

| | | | |
|------------------------------------|-----------|--------------------------------|--------|
| Motor current..... | 4 | STO..... | 16 |
| Motor output (U, V, W)..... | 20 | Supply voltage..... | 14, 15 |
| Motor power..... | 9 | Surroundings..... | 21 |
| Motor protection..... | 9, 21 | System feedback..... | 4 |
| Motor rotation check..... | 13 | | |
| Motor status..... | 4 | T | |
| Motor wiring..... | 7, 9, 17 | Temperature limit..... | 17 |
| Mounting..... | 17 | Terminal location, D1h..... | 12 |
| Multiple frequency converters..... | 9, 11 | Terminal location, D2h..... | 12 |
| | | Thermal protection..... | 5 |
| N | | Thermistor..... | 14 |
| Noise isolation..... | 7, 17 | Thermistor control wiring..... | 14 |
| | | Torque, terminal..... | 23 |
| O | | Transient protection..... | 4 |
| Open loop..... | 21 | Trip function..... | 9 |
| Optional equipment..... | 18 | Troubleshooting..... | 4 |
| Overload protection..... | 6, 9 | | |
| | | W | |
| P | | Wire type, rating..... | 10 |
| PELV..... | 14, 21 | Wiring, control terminal..... | 16 |
| Power..... | 10 | | |
| Power connection..... | 10 | | |
| Power factor..... | 4, 11, 17 | | |
| Pre-installation check list..... | 6 | | |
| Product overview..... | 3 | | |
| Programming..... | 4 | | |
| Protection..... | 22 | | |
| Protection, feature..... | 21 | | |
| | | | |
| R | | | |
| Relay output..... | 15 | | |
| Remote command..... | 4 | | |
| Reset..... | 21 | | |
| RFI filter..... | 13 | | |
| RMS current..... | 4 | | |
| RS485..... | 16 | | |
| | | | |
| S | | | |
| Safe torque off..... | 16 | | |
| Screened control cable..... | 15 | | |
| Screened control cable, using..... | 14 | | |
| Serial communication..... | 4, 15, 16 | | |
| Shielded cable..... | 7, 17 | | |
| Shielded wire..... | 9 | | |
| Specification..... | 4 | | |
| Start-up..... | 4 | | |



.....
Danfoss can accept no responsibility for possible errors in catalogues, brochures and other printed material. Danfoss reserves the right to alter its products without notice. This also applies to products already on order provided that such alterations can be made without subsequential changes being necessary in specifications already agreed. All trademarks in this material are property of the respective companies. Danfoss and the Danfoss logotype are trademarks of Danfoss A/S. All rights reserved.
.....

Danfoss A/S
Ulsnaes 1
DK-6300 Graasten
www.danfoss.com/drives

