



Operating Instructions

VLT[®] DriveMotor FCP 106 and FCM 106 BACnet



Contents

| | |
|---|-----------|
| 1 Introduction | 3 |
| 1.1 Purpose of the Manual | 3 |
| 1.2 Additional Resources | 3 |
| 1.3 Abbreviations and Conventions | 3 |
| 1.4 Technical Overview | 4 |
| 1.5 Copyright, Limitation of Liability and Revision Rights | 4 |
| 2 Safety | 6 |
| 2.1 Qualified Personnel | 6 |
| 2.2 Safety Precautions | 6 |
| 3 Installation | 8 |
| 3.1 BACnet Interface | 8 |
| 3.1.1 Safety Instructions | 8 |
| 3.1.2 Special Conditions | 8 |
| 3.1.3 Cabling | 9 |
| 3.1.4 Network Connection | 10 |
| 3.1.5 Cable Routing | 10 |
| 3.2 Bus Cabling | 11 |
| 3.2.1 EMC Precautions | 11 |
| 3.2.2 Screen | 11 |
| 3.2.3 Single Ground Screen | 11 |
| 4 System Configuration | 12 |
| 4.1 Configuring BACnet | 12 |
| 4.2 BACnet Set-up Example | 13 |
| 5 BACnet Objects | 14 |
| 5.1 Network Frequency Converter Control Inputs and -Outputs | 14 |
| 5.2 Frequency Converter Feedback to Network | 18 |
| 5.3 BIBBs | 18 |
| 5.4 Object/Property Support Matrix | 19 |
| 6 Parameters | 20 |
| 6.1 Parameter List | 20 |
| 6.2 Parameter Description | 21 |
| 7 Troubleshooting | 25 |
| 7.1 Alarm, Warning and Extended Status Word | 25 |
| 7.1.1 Alarm and Warning Messages | 25 |
| 7.1.2 Alarm Words | 26 |

| | |
|---------------------|-----------|
| 7.1.3 Warning Words | 27 |
| Index | 28 |

1 Introduction

1.1 Purpose of the Manual

This manual provides the information required to install and set up communication using BACnet protocol.

First-time users can obtain the most essential information for quick installation and set-up in these chapters

chapter 1 Introduction

chapter 3 Installation

chapter 4 System Configuration

For more detailed information including the full range of set-up options and diagnosis tools refer to the chapters:

chapter 6 Parameters

chapter 7 Troubleshooting

VLT® is a registered trademark.

1.2 Additional Resources

Literature available:

- *VLT® DriveMotor FCP 106 and FCM 106 Operating Instructions*, for information required to install and commission the frequency converter.
- *VLT® DriveMotor FCP 106 and FCM 106 Design Guide*, provides information required for integration of the frequency converter into a diversity of applications.
- *VLT® DriveMotor FCP 106 and FCM 106 Programming Guide*, for how to program the unit, including complete parameter descriptions.
- *VLT® LCP Instruction*, for operation of the local control panel (LCP).
- *VLT® LOP Instruction*, for operation of the local operation pad (LOP).
- *Modbus RTU Operating Instructions, Operating Instructions VLT® DriveMotor FCP 106 and FCM 106 BACnet and Operating Instructions VLT® DriveMotor FCP 106 and FCM 106 Metasys*, for information required for controlling, monitoring, and programming the frequency converter.
- *PC-based Configuration Tool MCT 10*, enables configuration of the frequency converter from a Windows™ based PC environment.
- *Danfoss VLT® Energy Box* software, for energy calculation in HVAC applications.

Technical literature and approvals are available online at www.danfoss.com/BusinessAreas/DrivesSolutions/Documentations/Technical+Documentation.

Danfoss VLT® Energy Box software is available at www.danfoss.com/BusinessAreas/DrivesSolutions, PC software download area.

1.3 Abbreviations and Conventions

| | |
|--------|--|
| ACI | Acyclical Control Interval |
| ACK | Acknowledge |
| ADF | Internal Floating Points |
| ADI | Internal Integers |
| AI | Analog Inputs |
| AO | Analog Outputs |
| AOC | Application Orientated Controller |
| AV | Analog Values |
| BI | Binary Inputs |
| BMS | Building Management System |
| BO | Binary Outputs |
| BV | Binary Values |
| COS | Change Of State |
| CTW | Control Word |
| EEPROM | Electrical Erasable Programmable Read Only Memory |
| EIA | Electronic Industries Association: Specifies of the EIA Standard RS-485-A |
| EMC | Electromagnetic Compatibility |
| HPFB | High Performance Field Bus |
| I/O | Input/Output |
| ISO | International Standards Organization |
| JCI | Johnson Controls Inc. developers of the METASYS N2 protocol |
| LCP | Local Control Panel |
| LED | Light Emitting Diode |
| MAV | Main Actual Value |
| MRV | Main Reference Value |
| N2 | METASYS N2 |
| N2 | A N2 master is either a PC with JCI software or a dedicated JCI controller |
| NAK | Not acknowledged |
| NPA | N2 Point Address (Each N2 Point Type has a address range from 0 to 255) |
| NPT | N2 Point Type |
| PC | Personal Computer |
| PDU | Protocol Data Unit |
| PELV | Protected Extra Low Voltage |
| PLC | Programmable Logic Control |
| PNU | Parameter Number |
| STW | Status Word |

Table 1.1 Abbreviations

Conventions

- Numbered lists indicate procedures.
- Bullet lists indicate
 - other information, and
 - description of illustrations.
- Italicised text indicates
 - cross reference
 - link
 - parameter name
- * indicates default setting of a parameter.

1.4 Technical Overview

BACnet (Building Automation and Control Network) is an open data communications protocol, American National Standard (ANSI/ASHRAE 135-2008). BACnet enables computer-based control equipment from different manufacturers to work together. BACnet is designed to handle many types of building controls, including HVAC, lighting, security, fire, access control, maintenance, and waste management. BACnet permits flexibility for expansion and different equipment combinations.

Conformance Classes, Function Groups, and the PICS: Evaluating the capabilities of a BACnet device is potentially a formidable task, given the great choice of Objects, Properties, and Services, which can be implemented. It is not necessary for every BACnet device to have a full BACnet implementation, to carry out its task. The ASHRAE BACnet Committee recognised this problem and responded with aids to evaluation in the form of "Conformance Classes," "Function Groups" and the "Protocol Implementation Conformance Statement" (PICS).

The BACnet protocol defines 6 levels of Conformance Classes, each of which specifies the minimum subset of Services implemented on the device. The lowest level, Conformance Class 1, requires only that the BACnet device contains a Device Object and that it is able to execute (respond to) a ReadProperty Service request. Each successive Conformance Class level adds Service Requests that must be executable by the device, as well as the Service Requests it must be able to initiate. Conformance Class 6 requires 21 types of Service Requests (of the 32 overall) to be implemented, of which 20 must be initiatable and 17 executable. Conformance Class thus provides a measure of the ability of the device to communicate.

Function Groups specify a combination of Objects and Services necessary to carry out certain building automation functions. They are specified independently of Conformance Class, though the implementation of some of

the Function Groups automatically confers some Conformance Class higher than 1.

| Background information | |
|----------------------------|--|
| Protocol name | BACnet |
| Technology developer | ASHRAE |
| Year introduced | 1995 |
| Governing standards | ANSI/ASHRAE Standard 135-2008 version 4, ISO 16484-5 |
| Openness | Open specification |
| Physical characteristics | |
| Network topology | Bus |
| Physical media | Shielded twisted pair |
| Max. Distance at low speed | 1200 m |
| Transport mechanism | |
| Communication methods | MS/TP |
| Baud Rates Supported | 9600, 19200, 38400, 76800 |
| Termination | 120 Ω |

Table 1.2 Overview

1.4.1 Assumptions

This manual assumes that

- the BACnet Protocol is used with the FCP 106 or FCM 106 frequency converter.
- the system is equipped with a firmware supporting the BACnet communication services required by the application
- all requirements stipulated in the BACnet standard, as well as those pertaining to the frequency converter are strictly observed as well as all limitations therein fully respected.

1.4.2 Background Knowledge

The Danfoss BACnet Protocol is designed to communicate with any system complying with the BACnet MS/TP standard. Familiarity with the PC, BMS or PLC used as a master in the system is assumed. Issues regarding hardware or software produced by other manufacturers are beyond the scope of this manual and are not the responsibility of Danfoss.

In case of questions regarding set-up of master-to-master communication or communication to a non-Danfoss follower, consult the appropriate manuals.

1.5 Copyright, Limitation of Liability and Revision Rights

This publication contains information proprietary to Danfoss. By accepting and using this manual the user agrees that the information contained herein is used solely for operating equipment from Danfoss or equipment from

other vendors if such equipment is intended for communication with Danfoss equipment over a serial communication link. This publication is protected under the Copyright laws of Denmark and most other countries.

Danfoss does not warrant that a software program produced according to the guidelines provided in this manual functions properly in every physical, hardware or software environment.

Although Danfoss has tested and reviewed the documentation within this manual, Danfoss makes no warranty or representation, neither expressed nor implied, with respect to this documentation, including its quality, performance, or fitness for a particular purpose.

In no event shall Danfoss be liable for direct, indirect, special, incidental, or consequential damages arising out of the use, or the inability to use information contained in this manual, even if advised of the possibility of such damages. In particular, Danfoss is not responsible for any costs, including but not limited to those incurred as a result of lost profits or revenue, loss or damage of equipment, loss of computer programs, loss of data, the costs to substitute these, or any claims by third parties.

Danfoss reserves the right to revise this publication at any time and to make changes to its contents without prior notice or any obligation to notify former or present users of such revisions or changes.

2

2 Safety

The following symbols are used in this document:

⚠ WARNING

Indicates a potentially hazardous situation which could result in death or serious injury.

⚠ CAUTION

Indicates a potentially hazardous situation which could result in minor or moderate injury. It may also be used to alert against unsafe practices.

NOTICE

Indicates important information, including situations that may result in damage to equipment or property.

2.1 Qualified Personnel

Correct and reliable transport, storage, installation, operation and maintenance are required for the trouble-free and safe operation of the frequency converter. Only qualified personnel is allowed to install or operate this equipment.

Qualified personnel is defined as trained staff, who are authorised to install, commission, and maintain equipment, systems and circuits in accordance with pertinent laws and regulations. Additionally, the personnel must be familiar with the instructions and safety measures described in this document.

2.2 Safety Precautions

⚠ WARNING

HIGH VOLTAGE

Frequency converters contain high voltage when connected to AC mains input power. Failure to perform installation, start up, and maintenance by qualified personnel could result in death or serious injury.

- Only qualified personnel are permitted to perform installation, start up, and maintenance.

⚠ WARNING

UNINTENDED START

When the frequency converter is connected to AC mains, the motor may start at any time, causing risk of death, serious injury, equipment, or property damage. The motor can start by means of an external switch, a serial bus command, an input reference signal from the LCP or LOP, or after a cleared fault condition.

- Disconnect the frequency converter from mains whenever personal safety considerations make it necessary to avoid unintended motor start.
- Press [Off/Reset] on the LCP, before programming parameters.
- The frequency converter, motor, and any driven equipment must be in operational readiness when the frequency converter is connected to AC mains.

⚠ WARNING

DISCHARGE TIME

The frequency converter contains DC-link capacitors, which can remain charged even when the frequency converter is not powered. Failure to wait the specified time after power has been removed before performing service or repair work, could result in death or serious injury.

1. Stop motor.
2. Disconnect AC mains, permanent magnet type motors, and remote DC-link power supplies, including battery back-ups, UPS, and DC-link connections to other frequency converters.
3. Wait for the capacitors to discharge fully, before performing any service or repair work. The duration of waiting time is specified in *Table 2.1*.

| Voltage [V] | Power Range ¹⁾ [kW] | Minimum waiting time (min) |
|---|--------------------------------|----------------------------|
| 3x400 | 0.55–7.5 | 4 |
| High voltage can be present even when the warning LED indicator lights are off. | | |

Table 2.1 Discharge Time

1) Power ratings relate to NO, see VLT® DriveMotor FCP 106 and FCM 106 Operating Instructions.

⚠ WARNING**EQUIPMENT HAZARD**

Contact with rotating shafts and electrical equipment can result in death or serious injury.

- Ensure that only trained and qualified personnel perform installation, start up, and maintenance.
- Ensure that electrical work conforms to national and local electrical codes.
- Follow the procedures in this manual.

⚠ CAUTION**WINDMILLING**

Unintended rotation of permanent magnet motors causes risk of personal injury and equipment damage.

- Ensure that permanent magnet motors are blocked to prevent unintended rotation.

⚠ WARNING**LEAKAGE CURRENT HAZARD**

Follow national and local codes regarding protective earthing of equipment with a leakage current exceeding 3.5 mA. Frequency converter technology implies high frequency switching at high power. This switching generates a leakage current in the ground connection. A fault current in the frequency converter at the output power terminals can contain a DC component which can charge the filter capacitors and cause a transient ground current. The ground leakage current depends on various system configurations including RFI filtering, screened motor cables, and frequency converter power. EN/ IEC61800-5-1 (Power Drive System Product Standard) requires special care because the leakage current exceeds 3.5 mA. See EN60364-5-54 paragraph 543.7 for further information.

- Ensure correct grounding of the equipment by a certified electrical installer.
- Grounding must be reinforced in one of the following ways:
 - Ensure ground wire with cross-section of at least 10 mm², or
 - Ensure 2 separate ground wires, both complying with the dimensioning rules.

NOTICE**HIGH ALTITUDES**

For installation at altitudes above 2000 m, contact Danfoss regarding PELV.

⚠ CAUTION**SHOCK HAZARD**

The frequency converter can cause a DC current in the PE conductor.

- When a residual current-operated protective device (RCD) is used for protection against electrical shock, only an RCD of Type B is permitted on the supply side.

Failure to follow the recommendation means the RCD may not provide the intended protection.

⚠ WARNING**GROUNDING HAZARD**

For operator safety, it is important to ground the frequency converter properly in accordance with national and local electrical codes, as well as the instructions in this manual. Ground currents are higher than 3.5 mA. Failure to ground the frequency converter properly could result in death or serious injury.

It is the responsibility of the user or certified electrical installer, to ensure correct grounding of the equipment in accordance with national and local electrical codes and standards.

- Follow all local and national electrical codes to ground electrical equipment properly.
- Establish proper protective grounding for equipment with current higher than 3.5 mA.
- A dedicated ground wire is required for input power, motor power, and control wiring.
- Use the clamps provided with on the equipment for proper ground connections.
- Do not ground one frequency converter to another in a "daisy chain" fashion.
- Keep the ground wire connections as short as possible.
- Use of high-strand wire to reduce electrical noise is recommended.
- Follow motor manufacturer wiring requirements.

3 Installation

3.1 BACnet Interface

3.1.1 Safety Instructions

See *chapter 2 Safety* for general safety instructions.

⚠ WARNING

INDUCED VOLTAGE

Induced voltage from output motor cables that run together can charge equipment capacitors even with the equipment turned off and locked out. Failure to run output motor cables separately or use screened cables could result in death or serious injury.

- run output motor cables separately, or
- use screened cables

⚠ CAUTION

SHOCK HAZARD

The frequency converter can cause a DC current in the PE conductor. Failure to follow the recommendation below means that the RCD may not provide the intended protection.

- When a residual current-operated protective device (RCD) is used for protection against electrical shock, only an RCD of Type B is permitted on the supply side.

Overcurrent protection

- Additional protective equipment such as short circuit protection or motor thermal protection between frequency converter and motor is required for applications with multiple motors.
- Input fusing is required to provide short circuit and overcurrent protection. If not factory-supplied, the installer provides fuses. See maximum fuse ratings in *VLT® DriveMotor FCP 106 and FCM 106 Operating Instructions*.

Wire Type and Ratings

- All wiring must comply with local and national regulations regarding cross section and ambient temperature requirements.
- Power connection wire recommendation: minimum 75 °C rated copper wire.

See *VLT® DriveMotor FCP 106 and FCM 106 Operating Instructions* for recommended wire sizes and types.

3.1.2 Special Conditions

Electrical ratings

The frequency converter rating, shown on the nameplate, is based on a typical 3-phase mains power supply within the specified voltage, current and temperature range, expected for most applications.

The frequency converters also support other special applications, which affect the electrical ratings of the frequency converter.

Special conditions which can affect the electrical ratings:

- Single phase applications
- High temperature applications which require derating of the electrical ratings
- Marine applications with more severe environmental conditions.

Other applications can also affect the electrical ratings.

Consult the relevant sections in this manual and in the *VLT® DriveMotor FCP 106 and FCM 106 Design Guide* for information about the electrical ratings.

Installation requirements

The overall electrical safety of the frequency converter requires special installation considerations regarding:

- Fuses and circuit breakers for overcurrent and short circuit protection
- Selection of power cables (mains, motor, brakeloadsharing, and relay)
- Grid configuration (grounded delta transformer leg, IT, TN, and so on)
- Safety of low-voltage ports (PELV conditions).

Consult the relevant clauses in this manual and in the *VLT® DriveMotor FCP 106 and FCM 106 Operating Instructions* for information about the installation requirements.

3.1.3 Cabling

Cable lengths and number of nodes

For the correct function of a BACnet MS/TP system, it is mandatory to fulfill installation of the communication cables given in this manual. Under correct installation it is possible to have up to 250 nodes (125 masters and 125 slaves) on 1,200 m (4,000 ft) cable.

The use of drop cable connection (i.e. T-connection) is not allowed in a BACnet MS/TP system. Drop cables lead to reflection and malfunction of the system. In locations where the cabling demands a T-connection the use of repeaters is recommended.

NOTICE

A repeater is a node in each of the 2 segments it connects. The number of frequency converters is based on a single master system. If there are 2 or more devices (e.g. PC tools, Routers), reduce the number of frequency converters correspondingly.

- Maximum length of an MS/TP segment: 1,200 m (4,000 ft)
- Characteristic impedance: 100 to 130 Ω
- Resistance: <110 Ω /km
- Distributed capacitance: <100 pF/m, between conductors
- Cross section: 0.82 mm² conductor area, corresponding to AWG 18
- Cable type: twisted in pairs, 1 x 2, or 2 x 2 wires
- Screening: Copper-braided screen or braided screen and foil screen

NOTICE

Use of the same cable type throughout the entire segment is recommended to avoid impedance mismatch.

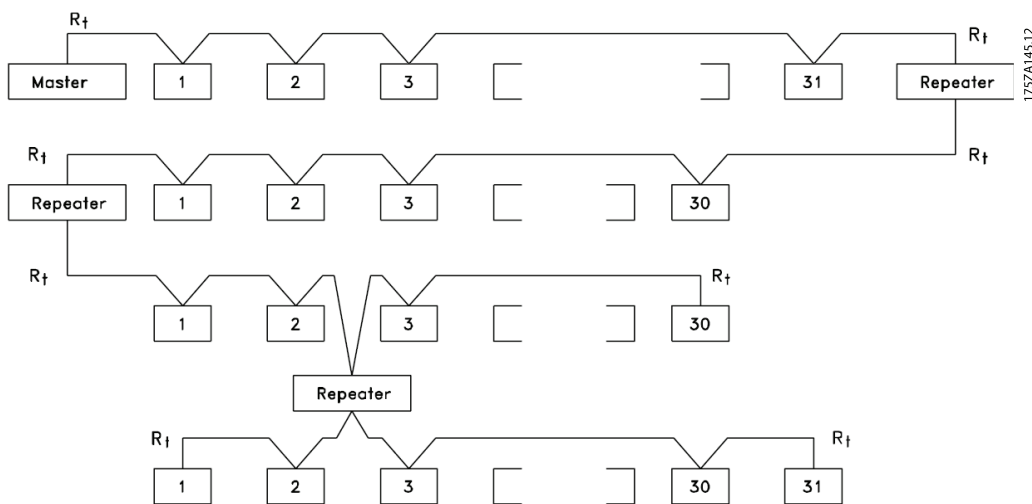

Illustration 3.1 BACnet Interface

3.1.4 Network Connection

Connect the frequency converter to the RS-485 network as follows (see also *Illustration 3.2*):

1. Connect signal wires to terminal 68 (P+) and terminal 69 (N-) on the main control board of the frequency converter.
2. Connect the cable screen to the cable clamps.
3. Terminal 61 is normally not used. However when there is a large potential difference between frequency converters, connect the screen of the RS-485 cable to terminal 61. Terminal 61 has an RC filter to eliminate current noise on the cable.

NOTICE

Screened, twisted-pair cables are recommended to reduce noise between conductors.

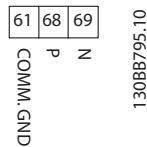

| | |
|-----------|----------------------|
| COMM. GND | Communication ground |
| P | (P+) Positive |
| N | (N-) Negative |

Illustration 3.2 Network Connection

4. Set the control card DIP switch to ON to terminate the RS-485 bus, and activate RS-485. For position of DIP switch, see *Illustration 3.3*. The factory setting for the DIP switch is OFF.

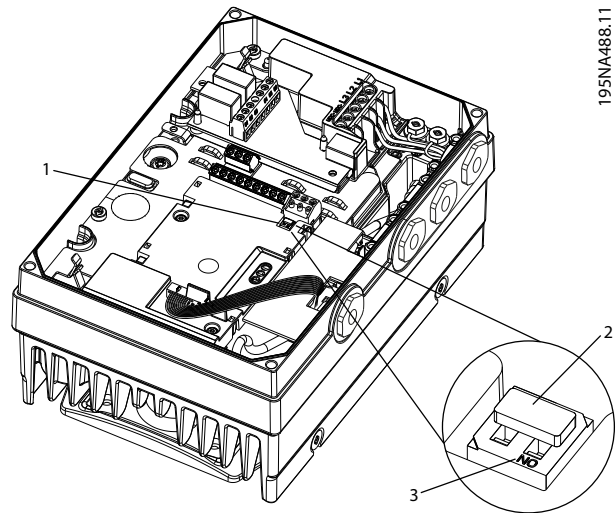

195NA488.11

| | |
|---|---|
| 1 | DIP switch |
| 2 | DIP switch set to factory setting, OFF position |
| 3 | DIP switch ON position |

Illustration 3.3 DIP Switch set to Factory Setting

3.1.5 Cable Routing

The BACnet communication cable must be kept away from motor and brake resistor cables to avoid coupling of high frequency noise from one cable to the other. Normally a distance of 200 mm is sufficient, but maintaining the greatest possible distance between cables is generally recommended, especially where cables run in parallel over long distances.

When crossing is unavoidable, the BACnet cable must cross motor and brake resistor cables at an angle of 90°.

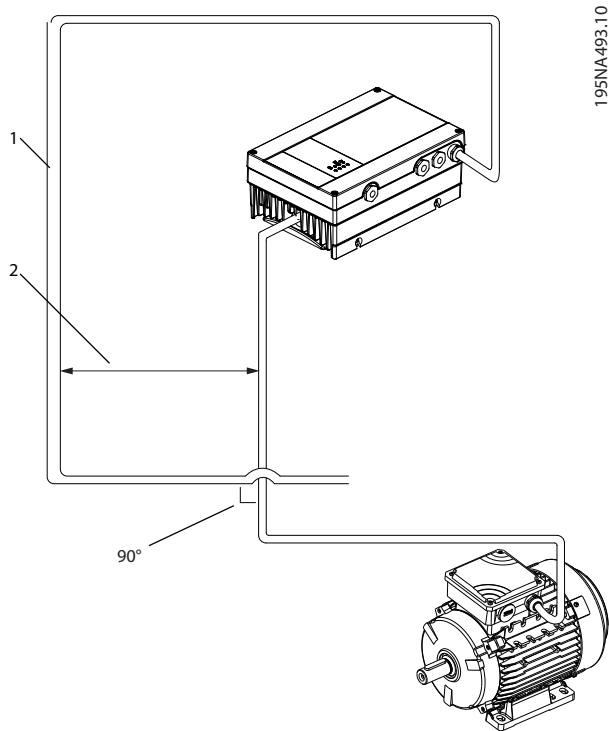

195NA493:10

| | |
|---|-------------------------|
| 1 | Fieldbus cable |
| 2 | Minimum 200 mm distance |

Illustration 3.4 Cable Routing

3.2 Bus Cabling

3.2.1 EMC Precautions

The following EMC precautions are recommended to achieve interference-free operation of the BACnet network. More EMC information is available in the *VLT® DriveMotor FCP 106 and FCM 106 Design Guide*.

NOTICE

Ensure compliance with relevant national and local regulations, for example in PE connection.

3.2.2 Screen

For installing the bus cable on MS/TP, 2 different strategies can be followed, each with advantages and disadvantages:

- single ground of screen
- multiple ground of screen

3.2.3 Single Ground Screen

The single ground screen is specified in the ANSI/ASRAHE 135-2004 standard. The solution benefits by having only one ground connection of the screen, by doing so the risk of ground loop of equalising current is heavily reduced. In

these systems the screen of the MS/TP cables must be isolated from ground at all stations, except one. At each station, the screens from the 2 cables must be connected with each other, and isolated from ground. The best solution for this connection is to use shrink tubes. The single ground screen is a good approach where the system uses long bus cables. For connection of 2 buildings over the same MS/TP bus cable, consider the use of fibre optic cable. Fibre optic cable prevents a lightning stroke transferring from one building to another, and the problem with difference in ground potential can be ignored.

3.2.4 Multiple Ground Screens

When the distance between the individual frequency converter is limited (for example, inside a cabinet or in one control room), Danfoss recommends connecting the screen to ground at both ends of the bus cable. This ensures the maximum protection from EMC noise. Connecting the screen at each end requires that each BACnet device has the same ground potential or an equalizing current flow in the screen of the cable. It causes disturbance and poor performance of the system. Low impedance to ground connection of the screen can be achieved by connecting the surface of the screen to ground, with a cable clamp or a conductive cable gland. The various clamps and brackets supplied enable a proper ground connection of the BACnet cable screen.

Danfoss recommends connection of the screen to ground at both ends of the bus cable, to ensure maximum protection from EMC noise. Connecting the screen at each end requires that each BACnet device has the same ground potential, otherwise an equalising current flows in the screen of the cable. This current causes disturbance and poor performance of the system. Alternatively, the screen can be isolated from the housing of the frequency converter using shrink-tubing. Routing of the BACnet cable must be established with correct distance to other cables, such as mains or motor cable

4 System Configuration

4.1 Configuring BACnet

4.1.1 Initialisation Procedure

4

| Parameter | Default Value | Setting for BACnet |
|-------------------------------|--------------------------|--------------------------|
| 8-01 Control Site | Digital and control word | Digital and control word |
| 8-02 Control Source | FC RS-485 | FC RS-485 |
| 8-03 Control Timeout Time | 1 s | ¹⁾ |
| 8-04 Control Timeout Function | Off | ¹⁾ |

Table 4.1 General Settings

| Parameter | Default Value | Setting for BACnet |
|-----------------------------|---------------|--------------------|
| 8-30 Protocol | FC | BACnet |
| 8-31 Address | 1 | ^{1 3)} |
| 8-32 Baud Rate | 9600 | 9600 baud |
| 8-35 Minimum Response Delay | 10 ms | 10 ms |
| 8-36 Maximum Response Delay | 5,000 ms | 5,000 ms |

Table 4.2 FC Port Settings

¹⁾ Depending on the application.

²⁾ Depending on the BMS system

³⁾ The address setting is dependent on the system. Each device connected to the BACnet MS/TP must have a unique address on this MS/TP network. See also chapter 6.1 Parameter List.

| Parameter | Default Value | Setting for BACnet |
|------------------------------|---------------|--|
| 8-50 Coasting Select | Logic-or | Set according to the wiring of the application |
| 8-52 DC Brake Select | Logic-or | Logic-or |
| 8-53 Start Select | Logic-or | Logic-or |
| 8-54 Reversing Select | Digital input | Digital input |
| 8-55 Set-up Select | Logic-or | Logic-or |
| 8-56 Preset Reference Select | Logic-or | Logic-or |

Table 4.3 Digital/Bus Settings

| Name | Default Value | Setting for BACnet |
|------------------------------|---------------|--|
| 8-70 BACnet Device Instance | 1 | ¹⁾ |
| 8-72 MS/TP Max Masters | 127 | Dependent on the Number of Masters in the system |
| 8-74 "I-Am" Service | At power up | At power up |
| 8-75 Initialisation Password | "admin" | "admin" |

Table 4.4 BACnet Settings

¹⁾ The device instance setting is dependent on the system. Each device connected to the BACnet MS/TP must have a unique device instance in the complete system.

4.1.2 Control Word Time-out Function

8-03 Control Timeout Time and 8-04 Control Timeout Function are not used.

4.2 BACnet Set-up Example

This example shows the necessary steps to set up the BACnet interface with the following system requirements:

- MS/TP running at 38,400 Baud
- MAC address 20 for the frequency converter on the MS/TP network
- Device Instance number 1025 for the frequency converter
- Highest number of a Master device is 35
- Start/stop of frequency converter from BACnet only
- Reference from BACnet
- Read status of frequency converter (Actual speed)

| Set the following parameters | |
|------------------------------|-----------------|
| Parameter | Value |
| 8-30 Protocol | [5] BACnet |
| 8-31 Address | 20 |
| 8-32 Baud Rate | [4] 38,400 Baud |
| 8-50 Coasting Select | [1] Bus |
| 8-70 BACnet Device Instance | 1025 |
| 8-72 MS/TP Max Masters | 35 |

Table 4.5 BACnet Set-up Example

After the parameters have been set according to *Table 4.5*, the frequency converter has to be unpowered and repowered before the changes take effect. When the frequency converter is detected by the BMS, it can be controlled by BV:1, which starts the motor if set to [1]. Setting AV:1 sets the speed reference of the frequency converter. The actual speed can be monitored via AV:3. See also *chapter 5.1.1 Analog Input and Output Objects*.

5 BACnet Objects

5.1 Network Frequency Converter Control Inputs and -Outputs

5.1.1 Analog Input and Output Objects

Control the frequency converter from the BACnet network using 'objects'. The various types of 'objects' and their descriptions are shown in the following tables.

5

| ID | Object_Name | Present_Value | |
|------|-----------------|---------------|------------|
| | Default name | Parameter | Unit |
| AI:0 | Analog Input 53 | 1662 | mA/Voltage |
| AI:1 | Analog Input 54 | 1664 | mA/Voltage |

Table 5.1 Analog Inputs Object Map

| ID | Object_Name | Present_Value | | | | |
|------|--------------------------------|---------------|----------------|-----------|----------|---------|
| | Default name | Parameter | Unit | Writeable | Cmd.able | Timeout |
| AO:0 | Terminal 42 Output Bus Control | 696 | N ₂ | x | x | x |
| AO:2 | Terminal 45 Output Bus Control | 676 | N ₂ | x | x | x |

Table 5.2 Analog Outputs

| ID | Object_Name | | | Present_Value | | | | |
|-------|--------------------------|-----------|--------|---------------|-------|-----------|----------|---------|
| | Default name | Writeable | EEPROM | Parameter | Unit | Writeable | Cmd.able | Timeout |
| AV:0 | Reserved for VFD profile | | | | | | | |
| AV:1 | Input Reference 1 | x | x | 1) | % | x | x | x |
| AV:2 | Input Reference 2 | | | 1) | % | x | x | x |
| AV:3 | Output Speed | x | x | 2) | % | | | |
| AV:4 | PI Feedback | | | 3) | % | | | |
| AV:5 | Motor Current | x | x | 1614 | Amps | | | |
| AV:6 | Power | x | x | 1610 | kW | | | |
| AV:7 | Reserved for VFD profile | | | | | | | |
| AV:8 | | | | | | | | |
| AV:9 | | | | | | | | |
| AV:10 | | | | | | | | |
| AV:11 | | | | | | | | |
| AV:12 | | | | | | | | |
| AV:13 | | | | | | | | |
| AV:14 | | | | | | | | |
| AV:15 | Motor Thermal | | | 1618 | % | | | |
| AV:16 | Reserved for VFD profile | | | | | | | |
| AV:17 | | | | | | | | |
| AV:18 | | | | | | | | |
| AV:19 | | | | | | | | |
| AV:20 | | | | | | | | |
| AV:21 | Operating Hours | | | 1500 | Hours | | | |

| ID | Object_Name | | | Present_Value | | | | |
|-------|------------------------|-----------|--------|---------------|----------------|-----------|----------|---------|
| | Default name | Writeable | EEPROM | Parameter | Unit | Writeable | Cmd.able | Timeout |
| AV:22 | Running Hours | | | 1501 | Hours | | | |
| AV:23 | kWh Counter | | | 1502 | kWh | | | |
| AV:24 | Motor Voltage | | | 1612 | V | | | |
| AV:25 | Frequency | | | 1613 | Hz | | | |
| AV:27 | DC Link Voltage | | | 1630 | V | | | |
| AV:28 | Heatsink Temp. | | | 1634 | °C | | | |
| AV:29 | Inverter Thermal | | | 1635 | % | | | |
| AV:31 | Bus Feedback 1 | | | 894 | N ₂ | x | | |
| AV:32 | Reserved for P, I | | | | | | | |
| AV:33 | | | | | | | | |
| AV:37 | Reserved for P, I | | | | | | | |
| AV:38 | | | | | | | | |
| AV:39 | | | | | | | | |
| AV:42 | Reserved for P, I | | | | | | | |
| AV:43 | | | | | | | | |
| AV:44 | | | | | | | | |
| AV:46 | | | | | | | | |
| AV:47 | | | | | | | | |
| AV:48 | | | | | | | | |
| AV:49 | | | | | | | | |
| AV:50 | Alarm Log: Error Code | | | 1530 | NONE | | | |
| AV:51 | Fault Code | | | 4) | NONE | | | |
| AV:52 | PID Start Speed | | | 2083 | Hz | x | | |
| AV:53 | On Reference Bandwidth | | | 2084 | % | x | | |
| AV:54 | PID Proportional Gain | | | 2093 | NONE | x | | |
| AV:55 | PID Integral Time | | | 2094 | S | x | | |

Table 5.3 Analog Values

1) Either AV:1 or AV:2 controls the frequency converter reference. Only one of them can control the frequency converter at a time and BV:2 decides which one.

2) This value is not directly available in the frequency converter. The value must be calculated as follows:

$$AV\#3 = \frac{Par. 16 - 13}{Par. 4 - 14} \times 100\%$$

3) This value is not directly available in the frequency converter. The value must be calculated as follows:

$$AV\#4 = \frac{Par. 16 - 52}{Par. 3 - 03} \times 100\%$$

4) Frequency converter fault codes are transmitted as an analog value in AV:51. The fault codes are mapped as shown in Table 5.4. The frequency converter alarm codes are shown as well for comparison.

Table 5.4 shows the mapping of the frequency converter alarm codes and their mapping to the BACnet's fault codes.

| Fault codes | Fault code | Frequency converter alarms | Fault descriptions |
|--------------------------|------------|--|--|
| Communication Error | 1 | 17 | Loss of communication with the network |
| Over Current | 2 | 59 | Instantaneous output current has exceeded frequency converter rated or programmed value |
| Over Temperature | 3 | 69 | Heat sink temperature limit has been reached |
| Over Speed Deviation | 4 | N.A. | N.A. |
| Over Voltage | 5 | 7 | DC link voltage has exceeded frequency converter limit |
| Under Voltage | 6 | 8 | DC link voltage is lower than required frequency converter limit |
| Short Circuit | 7 | 16 | Frequency converter output has shorted phase-to-phase |
| Ground Fault | 8 | 14 | Frequency converter output grounding current has exceeded manufacturer limitations |
| Motor Overload | 9 | 10 | Motor is overloaded |
| Inverter Overload | 10 | 9 | Timed over current fault |
| Over Torque Detection | 11 | N.A. | N.A. |
| External Fault | 12 | 2, 24, 43, 60, 63, | External fault has been activated in the frequency converter. This is a hard fault that must be reset. |
| Operator Interface Error | 13 | 46, 47, 50, 51, 52, 53, 54, 55, 56, 57, 58 | Inverter programming or operational interface malfunction |
| Load Loss | 14 | 93, 94, 95 | Load on the Motor is less than programmed limit of system. An Example is a broken belt or coupling |
| Configuration Error | 15 | 40, 41 | Errors exist in the programmed or operational configuration of the inverter |
| Feedback Failure | 16 | N.A. | N.A. |
| Output Phase Loss | 17 | 30, 31, 32 | One or more of the output phases from the inverter to the motor are open |
| Motor Stall | 18 | 11 | Motor is operating in stall region and not able to accelerate |
| Power Unit Error | 19 | N.A. | N.A. |
| Input Phase/DC Ripple | 20 | 4 | Input single phase or low line voltage condition |
| Internal Drive Failure | 21 | 38 | Manufacturer defined internal operations that have failed their-self checks. |

Table 5.4 Mapping of Fault Codes

5.1.2 Binary Input and Output Objects

| ID | Object_Name | Present_Value | |
|------|-----------------------|---------------|------------|
| | Default name | Parameter | Bit number |
| Bl:2 | Digital input Term 29 | 1660 | 2 |
| Bl:3 | Digital input Term 27 | 1660 | 3 |
| Bl:4 | Digital input Term 19 | 1660 | 4 |
| Bl:5 | Digital input Term 18 | 1660 | 5 |

Bl:10..Bl:15 are reserved for P1660/x

Table 5.5 Binary Inputs

| ID | Object_Name | Present_Value | | | | |
|------|--------------|---------------|------------|-----------|----------|---------|
| | Default name | Parameter | Bit number | Writeable | Cmd.able | Timeout |
| BO:4 | Relay 1 | 590 | 4 | x | x | x |
| BO:5 | Relay 2 | 590 | 5 | x | x | x |

Table 5.6 Binary Outputs

| ID | Object_Name | | | Present_Value | | | | | |
|-------|-----------------------------|-----------|--------|---------------------------------|--------------|-----------|----------|--------|---------|
| | Default name | Writeable | EEPROM | Parameter | Bit number | Writeable | Cmd.able | EEPROM | Timeout |
| BV:0 | Reserved for VFD profile | | | | | | | | |
| BV:1 | RUN/STOP Command | x | x | CTW=0x47C + Reversing bit 15 | 6 reverse 15 | x | x | | x |
| BV:2 | REF 1/REF 2 Select | x | x | Note 1 | n/a | x | x | x | x |
| BV:3 | Fault Reset Command | x | x | CTW | 7 | x | | | |
| BV:4 | RUN/STOP Monitor | x | x | STW | 1 | | | | |
| BV:5 | OK/FAULT Monitor | x | x | STW | 3, 6, 7 | | | | |
| BV:6 | HAND/AUTO Reference | x | x | 16-95 | 1 | | | | |
| BV:7 | Reserved for VFD profile | | | | | | | | |
| BV:8 | | | | | | | | | |
| BV:9 | | | | | | | | | |
| BV:10 | | | | | | | | | |
| BV:11 | | | | | | | | | |
| BV:12 | | | | | | | | | |
| BV:13 | | | | | | | | | |
| BV:14 | | | | | | | | | |
| BV:15 | | | | | | | | | |
| BV:16 | | | | | | | | | |
| BV:17 | | | | | | | | | |
| BV:18 | | | | | | | | | |
| BV:19 | | | | | | | | | |
| BV:20 | | | | | | | | | |
| BV:21 | Warning | x | x | STW | 7 | | | | |
| BV:22 | Trip | x | x | STW | 3 | | | | |
| BV:23 | Triplock | | | STW | 6 | | | | |
| BV:24 | Coasting | | | CTW | 3 | x | x | | x |
| BV:25 | CW/CCW | | | CTW | 15 | x | x | | x |
| BV:26 | Jog | | | CTW | 8 | x | x | | x |
| BV:27 | Reset | | | CTW | 7 | x | x | | x |
| BV:28 | Reset KWh Counter | | | 1506 | n/a | x | | | |
| BV:29 | Reset Running Hours Counter | | | 1507 | n/a | x | | | |
| BV:31 | Speed = reference | | | STW | 8 | | | | |
| BV:32 | Bus control | | | STW | 9 | | | | |
| BV:33 | Running | x | x | STW | 11 | | | | |
| BV:34 | Ramp 1/ Ramp 2 | | | CTW | 9 | x | x | | |

Table 5.7 Binary Values

5.1.3 Multi-state Value Objects

| ID | Object_Name | Present_Value | | | | Timeout |
|-------|------------------------------|---------------|------------|-----------|----------|---------|
| | Default name | Parameter | Bit number | Writeable | Cmd.able | |
| MSV:0 | Smart Logic Controller State | 1638 | n/a | | | |
| MSV:1 | Active Setup | CTW | 13 | x | x | x |

Table 5.8 Multi-state Value

5.2 Frequency Converter Feedback to Network

5

The BACnet option provides several output variables (nvo's) objects to the network, containing important frequency converter-, motor- and I/O feedback data. The BACnet option transmits bound network variables only and sends feedback data when there is a change in value.

Influence of the digital input terminals upon the FC Control Mode, *8-50 Coasting Select* to *8-56 Preset Reference Select*

The influence of the digital input terminals upon control of the frequency converter can be programmed in *8-50 Coasting Select* to *8-56 Preset Reference Select*.

NOTICE

8-01 Control Site overrules the settings in *8-50 Coasting Select* to *8-56 Preset Reference Select* and *Terminal 37, Safe Stop* overrules any parameter.

Each of the digital input signals can be programmed to logic AND, logic OR, or to have no relation to the corresponding bit in the control word. In this way a specific control command i.e. stop/coast, can be initiated by the fieldbus only, fieldbus AND Digital Input, or Fieldbus OR Digital input terminal.

NOTICE

To control the frequency converter via BACnet, set *8-50 Coasting Select* to either [1] *Bus* or to [2] *Logic AND* and set *8-01 Control Site* to [0] *Digital and ctrl. word* or [2] *Control word only*.

5.3 BIBBs

| | |
|----------------------------|----------|
| ReadProperty | Execute |
| WriteProperty | Execute |
| DeviceCommunicationControl | Execute |
| ReinitializeDevice | Execute |
| I-Am | Initiate |
| I-Have | Initiate |
| TimeSynchronization | Execute |
| Who-Has | Execute |
| Who-Is | Execute |

Table 5.9 BIBBs

5.4 Object/Property Support Matrix

For an overview of the object types and properties supported, see *Table 5.10*.

| Property | Device | Binary input | Binary output | Binary value | Analog input | Analog output | Analog value | Multistage value |
|-------------------------|--------|--------------|---------------|--------------|--------------|---------------|--------------|------------------|
| Object identifier | x | x | x | x | x | x | x | x |
| Object Name | x | x | x | x | x | x | x | x |
| Object Type | x | x | x | x | x | x | x | x |
| System Status | x | | | | | | | |
| Vendor Name | x | | | | | | | |
| Vendor Identifier | x | | | | | | | |
| Model Name | x | | | | | | | |
| Firmware Revision | x | | | | | | | |
| Appl. Software Revision | x | | | | | | | |
| Location | x | | | | | | | |
| Description | x | | | | | | | |
| Protocol Version | x | | | | | | | |
| Protocol Revision | x | | | | | | | |
| Services Supported | x | | | | | | | |
| Object List | x | | | | | | | |
| Max. APDU Length | x | | | | | | | |
| Segmentation Support | x | | | | | | | |
| Local Time | x | | | | | | | |
| Local Date | x | | | | | | | |
| APDU Timeout | x | | | | | | | |
| Number APDU Retries | x | | | | | | | |
| Max Master | x | | | | | | | |
| Max Info Frames | x | | | | | | | |
| Device Address Binding | x | | | | | | | |
| Database Revision | x | | | | | | | |
| Present Value | | x | x | x | x | x | x | x |
| Status Flags | | x | x | x | x | x | x | x |
| Event State | | x | x | x | x | x | x | x |
| Reliability | | x | x | x | x | x | x | x |
| Out-of-Service | | x | x | x | x | x | x | x |
| Number of States | | | | | | | | x |
| State Text | | | | | | | | x |
| Units | | | | | x | x | x | |
| Priority Array | | | x | x* | | x | x* | x* |
| Relinquish Default | | | x | x* | | x | x* | x* |
| Polarity | | x | x | | | | | |
| Active Text | | x | x | x | | | | |
| Inactive Text | | x | x | x | | | | |

Table 5.10 Object/Property Support Matrix

*For commandable values only

6 Parameters

6.1 Parameter List

6.1.1 8-** Comm. and Options

| Par. No. # | Parameter description | Default value | 2-set-up | Change during operation | Conversion index | Type |
|---------------------------------|---------------------------|---------------------------|-------------|-------------------------|------------------|------------|
| 8-0* General Settings | | | | | | |
| 8-01 | Control Site | [0] Digital and ctrl.word | All set-ups | TRUE | - | Uint8 |
| 8-02 | Control Source | [1] FC Port | All set-ups | TRUE | - | Uint8 |
| 8-03 | Control Timeout Time | 1.0 s | 1 set-up | TRUE | -1 | Uint16 |
| 8-04 | Control Timeout Function | [0] Off | 1 set-up | TRUE | - | Uint8 |
| 8-3* FC Port Settings | | | | | | |
| 8-30 | Protocol | [0] FC | 1 set-up | TRUE | - | Uint8 |
| 8-31 | Address | 1.0 N/A | 1 set-up | TRUE | 0 | Uint8 |
| 8-32 | Baud Rate | ExpressionLimit | 1 set-up | TRUE | - | Uint8 |
| 8-33 | Parity / Stop Bits | ExpressionLimit | 1 set-up | TRUE | - | Uint8 |
| 8-35 | Minimum Response Delay | 0.01 s | 1 set-up | TRUE | -3 | Uint16 |
| 8-36 | Maximum Response Delay | ExpressionLimit | 1 set-up | TRUE | -3 | Uint16 |
| 8-4* FC MC protocol set | | | | | | |
| 8-42 | PCD Write Configuration | ExpressionLimit | All set-ups | TRUE | 0 | Uint8 |
| 8-43 | PCD Read Configuration | ExpressionLimit | All set-ups | TRUE | 0 | Uint8 |
| 8-5* Digital/Bus | | | | | | |
| 8-50 | Coasting Select | [3] Logic OR | All set-ups | TRUE | - | Uint8 |
| 8-51 | Quick Stop Select | [3] Logic OR | All set-ups | TRUE | - | Uint8 |
| 8-52 | DC Brake Select | [3] Logic OR | All set-ups | TRUE | - | Uint8 |
| 8-53 | Start Select | [3] Logic OR | All set-ups | TRUE | - | Uint8 |
| 8-54 | Reversing Select | [0] Digital input | All set-ups | TRUE | - | Uint8 |
| 8-55 | Set-up Select | [3] Logic OR | All set-ups | TRUE | - | Uint8 |
| 8-56 | Preset Reference Select | [3] Logic OR | All set-ups | TRUE | - | Uint8 |
| 8-7* BACnet | | | | | | |
| 8-70 | BACnet Device Instance | 1 N/A | 1 set-up | TRUE | 0 | Uint32 |
| 8-72 | MS/TP Max Masters | 127.0 N/A | 1 set-up | TRUE | 0 | Uint8 |
| 8-73 | MS/TP Max Info Frames | 1.0 N/A | 1 set-up | TRUE | 0 | Uint16 |
| 8-74 | "I am" Service | [0] Send at power-up | 1 set-up | TRUE | - | Uint8 |
| 8-75 | Intialisation Password | [admin] | 1 set-up | TRUE | 0 | VisStr[21] |
| 8-79 | Protocol Firmware version | ExpressionLimit | 1 set-up | TRUE | -2 | Uint16 |
| 8-8* FC Port Diagnostics | | | | | | |
| 8-80 | Bus Message Count | 0.0 N/A | 1 set-up | TRUE | 0 | Uint32 |
| 8-81 | Bus Error Count | 0.0 N/A | 1 set-up | TRUE | 0 | Uint32 |
| 8-82 | Slave Messages Rcvd | 0.0 N/A | 1 set-up | TRUE | 0 | Uint32 |
| 8-83 | Slave Error Count | 0.0 N/A | 1 set-up | TRUE | 0 | Uint32 |
| 8-84 | Slave Messages Sent | 0.0 N/A | 1 set-up | TRUE | 0 | Uint32 |
| 8-85 | Slave Timeout Errors | 0.0 N/A | 1 set-up | TRUE | 0 | Uint32 |
| 8-88 | Reset FC port Diagnostics | [0] Do not reset | 1 set-up | TRUE | - | Uint8 |
| 8-9* Bus Feedback | | | | | | |
| 8-94 | Bus Feedback 1 | 0.0 N/A | All set-ups | TRUE | 0 | Int16 |

6.2 Parameter Description

6.2.1 8-0* General Settings

| 8-01 Control Site | | |
|-------------------|-----------------------|--|
| Option: | Function: | |
| | | Select [0] <i>Digital and ctrl.word</i> for using digital input and control word. Select [1] <i>Digital only</i> to use digital inputs only. Select [2] <i>Control word only</i> to use control word only. This parameter overrules settings in <i>parameter 8-50 Coasting Select</i> to <i>parameter 8-56 Preset Reference Select</i> . |
| [0] | Digital and ctrl.word | Control by using both digital input and control word. |
| [1] | Digital only | Control by using digital inputs only. |
| [2] | Controlword only | Control by using control word only. |

| 8-02 Control Source | | |
|---------------------|-----------|---|
| Option: | Function: | |
| | | <p>NOTICE</p> <p>This parameter cannot be adjusted while the motor is running.</p> <p>Select the source of the control word.</p> |
| [0] | None | |
| [1] * | FC Port | |

| 8-03 Control Timeout Time | | |
|---------------------------|-----------|---|
| Range: | Function: | |
| 1 s* [0.1 - 6500 s] | | Enter the maximum time expected to pass between the reception of 2 consecutive telegrams. If this time is exceeded, it indicates that the serial communication has stopped. The function selected in <i>parameter 8-04 Control Timeout Function Control Time-out Function</i> is carried out. |

| 8-04 Control Timeout Function | | |
|-------------------------------|-----------|--|
| Option: | Function: | |
| | | Select the timeout function. The time-out function is activated when the control word fails to be updated within the time period specified in <i>parameter 8-03 Control Timeout Time</i> . |
| [0] * | Off | |

6.2.2 8-3* FC Port Settings

| 8-30 Protocol | | |
|---------------|-----------|---|
| Option: | Function: | |
| | | Select the protocol for the integrated RS-485 port. |

| 8-30 Protocol | | |
|---------------|------------|---|
| Option: | Function: | |
| [0] | FC | Communication according to the FC Protocol. |
| [2] | Modbus RTU | Communication according to the Modbus RTU protocol. |
| [3] | Metasys N2 | Communication protocol. The N2 software protocol is designed to accommodate the unique properties each device may have. |
| [5] | BACNet | |

| 8-31 Address | | |
|-----------------|-----------|---|
| Range: | Function: | |
| 1* [0.0 - 247] | | Enter the address for the RS-485 port. Valid range: 1-126 for FC-bus OR 1-247 for Modbus. |

| 8-32 Baud Rate | | |
|----------------|-------------|---|
| Option: | Function: | |
| | | Select the baud rate for the RS-485 port Default refers to the FC Protocol. Changing Protocol in <i>8-30 Protocol</i> may change the Baud Rate. Changing Protocol in <i>8-30 Protocol</i> may change the Baud Rate. |
| [0] | 2400 Baud | |
| [1] | 4800 Baud | |
| [2] | 9600 Baud | Default setting for <ul style="list-style-type: none"> • Modbus RTU • BACnet • Metasys N2 |
| [3] | 19200 Baud | |
| [4] | 38400 Baud | |
| [5] | 57600 Baud | |
| [6] | 76800 Baud | |
| [7] | 115200 Baud | |

| 8-33 Parity / Stop Bits | | |
|-------------------------|-------------------------|--|
| Option: | Function: | |
| | | Parity and stop bits for the protocol using the FC Port. For some of the protocols, not all options are available. Default refers to the FC Protocol. |
| [0] | Even Parity, 1 Stop Bit | |
| [1] | Odd Parity, 1 Stop Bit | |
| [2] | No Parity, 1 Stop Bit | |
| [3] | No Parity, 2 Stop Bits | |

| 8-35 Minimum Response Delay | | |
|-----------------------------|-----------|--|
| Range: | Function: | |
| 0.01 s* [0.0010 - 0.5 s] | | Specify the minimum delay time between receiving a request and transmitting a response. This is used for |

6.2.3 8-5* Digital/Bus

Parameters for configuring the control word Digital/Bus merging.

| 8-35 Minimum Response Delay | | |
|-----------------------------|--|-------------------------------------|
| Range: | | Function: |
| | | overcoming modem turnaround delays. |

| 8-36 Maximum Response Delay | | |
|-----------------------------|----------------|--|
| Range: | | Function: |
| Size related* | [0.1 - 10.0 s] | Specify the maximum permissible delay time between receiving a request and transmitting the response. If this time is exceeded, no response is returned. |

| 8-50 Coasting Select | | |
|----------------------|---------------|---|
| Option: | | Function: |
| | | Select control of the coasting function via the terminals (digital input) and/or via the bus. NOTICE This parameter is active only when <i>parameter 8-01 Control Site</i> is set to [0] <i>Digital and control word</i> . |
| [0] | Digital input | Activates coast via a digital input. |
| [1] | Bus | Activates coast via the serial communication port. |
| [2] | Logic AND | Activates coast via the fieldbus/serial communication port, AND additionally via one of the digital inputs. |
| [3] * | Logic OR | Activates coast via the serial communication port OR via one of the digital inputs. |

| 8-51 Quick Stop Select | | |
|------------------------|---------------|---|
| Option: | | Function: |
| | | Select control of the Quick Stop function via the terminals (digital input) and/or via the bus. NOTICE This parameter is active only when <i>parameter 8-01 Control Site</i> is set to [0] <i>Digital and control word</i> . |
| [0] | Digital input | Activates Quick Stop via a digital input. |
| [1] | Bus | Activates Quick Stop via the serial communication port. |

| 8-51 Quick Stop Select | | |
|------------------------|-----------|---|
| Option: | | Function: |
| [2] | Logic AND | Activates Quick Stop via the serial communication port, AND additionally via one of the digital inputs. |
| [3] * | Logic OR | Activates Quick Stop via the serial communication port OR via one of the digital inputs. |

| 8-52 DC Brake Select | | |
|----------------------|---------------|---|
| Option: | | Function: |
| | | Select control of the DC brake via the terminals (digital input). NOTICE This parameter is active only when <i>parameter 8-01 Control Site</i> is set to [0] <i>Digital and control word</i> . |
| [0] | Digital input | Activates DC brake via a digital input. |
| [1] | Bus | Activates DC brake via the serial communication port. |
| [2] | Logic AND | Activates DC brake via the serial communication port, AND additionally via one of the digital inputs. |
| [3] | Logic OR | Activates DC brake via the serial communication port OR via one of the digital inputs. |

| 8-53 Start Select | | |
|-------------------|---------------|---|
| Option: | | Function: |
| | | Select control of the frequency converter start function via the terminals (digital input). NOTICE This parameter is active only when <i>parameter 8-01 Control Site</i> is set to [0] <i>Digital and control word</i> . |
| [0] | Digital input | Activates Start command via a digital input. |
| [1] | Bus | Activates Start command via the serial communication port. |
| [2] | Logic AND | Activates Start command via the serial communication port, AND additionally via one of the digital inputs. |
| [3] * | Logic OR | Activates Start command via the serial communication port OR via one of the digital inputs. |

| 8-54 Reversing Select | | |
|-----------------------|--|--|
| Option: | | Function: |
| | | Select control of the frequency converter reverse function via the terminals (digital input) and/or via the serial communication port. |

| 8-54 Reversing Select | | |
|-----------------------|---------------|--|
| Option: | Function: | |
| | | <p>NOTICE</p> <p>This parameter is active only when parameter 8-01 Control Site is set to [0] Digital and control word.</p> |
| [0] * | Digital input | Activates Reverse command via a digital input. |
| [1] | Bus | Activates Reverse command via the serial communication port. |
| [2] | Logic AND | Activates Reverse command via the serial communication port, AND additionally via one of the digital inputs. |
| [3] | Logic OR | Activates Reverse command via the serial communication port OR via one of the digital inputs. |

| 8-55 Set-up Select | | |
|--------------------|---------------|--|
| Option: | Function: | |
| | | <p>Select control of the frequency converter set-up selection via the terminals (digital input) and/or via the serial communication port.</p> <p>NOTICE</p> <p>This parameter is active only when parameter 8-01 Control Site is set to [0] Digital and control word.</p> |
| [0] | Digital input | Activates the set-up selection via a digital input. |
| [1] | Bus | Activates the set-up selection via the serial communication port. |
| [2] | Logic AND | Activates the set-up selection via the serial communication port, AND additionally via one of the digital inputs. |
| [3] * | Logic OR | Activate the set-up selection via the serial communication port OR via one of the digital inputs. |

| 8-56 Preset Reference Select | | |
|------------------------------|---------------|--|
| Option: | Function: | |
| | | Select control of the frequency converter Preset Reference selection via the terminals (digital input) and/or via the serial communication port. |
| [0] | Digital input | Activates Preset Reference selection via a digital input. |
| [1] | Bus | Activates Preset Reference selection via the serial communication port. |
| [2] | Logic AND | Activates Preset Reference selection via the serial communication port, AND additionally via one of the digital inputs. |

| 8-56 Preset Reference Select | | |
|------------------------------|-----------|--|
| Option: | Function: | |
| [3] * | Logic OR | Activates the Preset Reference selection via the serial communication port OR via one of the digital inputs. |

6.2.4 8-7* BACnet

| 8-70 BACnet Device Instance | | |
|-----------------------------|----------------|---|
| Range: | Function: | |
| 1* | [0 - 4194303] | Enter a unique ID number for the BACnet device. |

| 8-72 MS/TP Max Masters | | |
|------------------------|------------|--|
| Range: | Function: | |
| 127* | [0 - 127] | Define the address of the master which holds the highest address in this network. Decreasing this value optimises polling for the token. |

| 8-73 MS/TP Max Info Frames | | |
|----------------------------|--------------|---|
| Range: | Function: | |
| 1* | [1 - 65534] | Define how many info/data frames the device is allowed to send while holding the token. |

| 8-74 "I am" Service | | |
|---------------------|------------------|---|
| Option: | Function: | |
| [0] * | Send at power-up | Select when the device should send the "I-Am" service message only at power-up. |
| [1] | Continuously | Select when the device should send the "I-Am" service message continuously with an interval of approx. 1 min. |

| 8-75 Intialisation Password | | |
|-----------------------------|-----------|---|
| Range: | Function: | |
| admin* | [1 - 1] | Enter the password needed for execution of Drive Re-initialisation. |

| 8-79 Protocol Firmware version | | |
|--------------------------------|--------------|---|
| Range: | Function: | |
| Size related* | [0 - 65535] | Read the supported protocol version. Index 5 is for BACNet. |

6.2.5 8-8* FC Port Diagnostics

These parameters are used for monitoring the Bus communication via the FC Port.

| 8-80 Bus Message Count | | |
|------------------------|--------------|---|
| Range: | Function: | |
| 0* | [0 - 65536] | This parameter shows the number of valid telegrams detected on the bus. |

| 8-81 Bus Error Count | | |
|----------------------|---|--|
| Range: | Function: | |
| 0* [0 - 65536] | This parameter shows the number of telegrams with faults (e.g. CRC fault), detected on the bus. | |

| 8-82 Slave Messages Rcvd | | |
|--------------------------|--|--|
| Range: | Function: | |
| 0* [0 - 65536] | This parameter shows the number of valid telegrams addressed to the follower, sent by the frequency converter. | |

| 8-83 Slave Error Count | | |
|------------------------|---|--|
| Range: | Function: | |
| 0* [0 - 65536] | This parameter shows the number of error telegrams, which could not be executed by the frequency converter. | |

| 8-84 Slave Messages Sent | | |
|--------------------------|---|--|
| Range: | Function: | |
| 0* [0 - 65536] | This parameter shows the number of messages sent from the follower. | |

| 8-85 Slave Timeout Errors | | |
|---------------------------|---|--|
| Range: | Function: | |
| 0* [0 - 65536] | This parameter shows the number of follower timeout errors. | |

| 8-88 Reset FC port Diagnostics | | |
|--------------------------------|---------------|--|
| Option: | Function: | |
| [0] * | Do not reset | |
| [1] | Reset counter | |

6.2.6 8-9* Bus Feedback

| 8-94 Bus Feedback 1 | | |
|----------------------|---|--|
| Range: | Function: | |
| 0* [-32768 - 32767] | Write a feedback to this parameter via the serial communication port. This parameter must be selected in <i>20-00 Feedback 1 Source</i> as a feedback source. (Hex-value 4000 h corresponds to 100% feedback/range is $\pm 200\%$) | |

7 Troubleshooting

7.1 Alarm, Warning and Extended Status Word

7.1.1 Alarm and Warning Messages

General

There is a clear distinction between alarms and warnings. In the event of an alarm, the frequency converter enters a fault condition. After the cause for the alarm has been cleared, the master must acknowledge the alarm message to restart operation of the frequency converter. A warning, on the other hand, may appear when a warning condition arises, then disappear when conditions return to normal without interfering with the process.

Alarm words and warning words are shown on the display in hex format. If there is more than one warning or alarm, a sum of all warnings or alarms is shown. Warning words and alarm word are displayed in parameters *16-90 Alarm Word* to *16-95 Ext. Status Word 2*. For more information on the individual alarms and warnings, refer to the *VLT® DriveMotor FCP 106 and FCM 106 Programming Guide*.

Warnings

All warnings within the frequency converter are represented by a single bit within a warning word. A warning word is always an action parameter. Bit status *[0] FALSE* means no warning, while bit status *[1] TRUE* means warning. Each bit status has a corresponding text string message. In addition to the warning word message the master is also notified via a change to bit 7 in the status word.

Alarms

Following an alarm message the frequency converter enters a fault condition. Only after the fault has been rectified and the master has acknowledged the alarm message by setting bit 3 in the control word, can the frequency converter resume operation. All alarms within the frequency converter are represented by a single bit within an alarm word. An alarm word is always an action parameter. Bit status *[0] FALSE* means no alarm, while bit status *[1] TRUE* means alarm.

7.1.2 Alarm Words

| Bit (Hex) | Alarm Word (16-90 Alarm Word) |
|-----------|----------------------------------|
| 00000001 | |
| 00000002 | Power card overtemperature |
| 00000004 | Earth fault |
| 00000008 | |
| 00000010 | Control word timeout |
| 00000020 | Over current |
| 00000040 | |
| 00000080 | Motor thermistor overtemperature |
| 00000100 | Motor ETR over temperature |
| 00000200 | Inverter overloaded |
| 00000400 | DC-link undervoltage |
| 00000800 | DC-link overvoltage |
| 00001000 | Short circuit |
| 00002000 | |
| 00004000 | Mains phase loss |
| 00008000 | AMA not OK |
| 00010000 | Live zero error |
| 00020000 | Internal fault |
| 00040000 | |
| 00080000 | Motor phase U is missing |
| 00100000 | Motor phase V is missing |
| 00200000 | Motor phase W is missing |
| 00800000 | Control Voltage Fault |
| 01000000 | |
| 02000000 | VDD, supply low |
| 10000000 | DESAT Earth fault |
| 20000000 | Drive initialised |
| 80000000 | |

Table 7.1 16-90 Alarm Word

| Bit (Hex) | Alarm Word 2 (16-91 Alarm Word 2) |
|-----------|-----------------------------------|
| 00000001 | |
| 00000002 | Gate drive voltage fault |
| 00000004 | Reserved |
| 00000008 | Reserved |
| 00000010 | Reserved |
| 00000020 | |
| 00000040 | No flow |
| 00000080 | End of Curve |
| 00000100 | Broken Belt |
| 00000200 | Not used |
| 00000400 | Not used |
| 00000800 | Flow/Pressure info missing |
| 00001000 | Reserved |
| 00002000 | Reserved |
| 00004000 | Reserved |
| 00008000 | Flow/Pressure info missing |
| 00010000 | Reserved |
| 00020000 | Not used |
| 00040000 | Fans error |
| 00080000 | Reserved |
| 00100000 | Reserved |
| 00200000 | Reserved |
| 00400000 | Locked Rotor |
| 00800000 | Reserved |
| 01000000 | Reserved |
| 02000000 | Current Limit |
| 04000000 | Reserved |
| 08000000 | Reserved |
| 10000000 | Reserved |
| 20000000 | Reserved |

Table 7.2 16-91 Alarm Word 2

7.1.3 Warning Words

| Bit (Hex) | Warning Word (16-92 Warning Word) |
|-----------|-----------------------------------|
| 00000001 | |
| 00000002 | Power card overtemperature |
| 00000004 | Earth fault |
| 00000008 | |
| 00000010 | Control word timeout |
| 00000020 | Over current |
| 00000040 | |
| 00000080 | Motor thermistor overtemperature. |
| 00000100 | Motor ETR over temperature |
| 00000200 | Inverter overloaded |
| 00000400 | DC-link undervoltage |
| 00000800 | DC-link overvoltage |
| 00001000 | |
| 00002000 | |
| 00004000 | Mains phase loss |
| 00008000 | No motor |
| 00010000 | Live zero error |
| 00020000 | |
| 00040000 | |
| 00080000 | |
| 00100000 | |
| 00200000 | |
| 00400000 | |
| 00800000 | 24 V supply fault |
| 01000000 | |
| 02000000 | Current limit |
| 04000000 | Low temperature |
| 08000000 | |
| 10000000 | |
| 20000000 | |
| 40000000 | Not used |
| 80000000 | Not used |

Table 7.3 16-92 Warning Word

| Bit (Hex) | Warning Word 2 (16-93 Warning Word 2) |
|-----------|---------------------------------------|
| 00000001 | |
| 00000002 | |
| 00000004 | |
| 00000008 | Reserved |
| 00000010 | Reserved |
| 00000020 | |
| 00000040 | Dry Pump |
| 00000080 | End of Curve |
| 00000100 | Broken Belt |
| 00000200 | Not used |
| 00000400 | Reserved |
| 00000800 | Reserved |
| 00001000 | Reserved |
| 00002000 | Reserved |
| 00004000 | Reserved |
| 00008000 | Auto DC Braking |
| 00010000 | Reserved |
| 00020000 | Not used |
| 00040000 | Fans warning |
| 00080000 | |
| 00100000 | Reserved |
| 00200000 | Reserved |
| 00400000 | Reserved |
| 00800000 | Reserved |
| 01000000 | Reserved |
| 02000000 | Reserved |
| 04000000 | Reserved |
| 08000000 | Reserved |
| 10000000 | Reserved |
| 20000000 | Back EMF too high |
| 40000000 | Reserved |
| 80000000 | Reserved |

Table 7.4 16-93 Warning Word 2

Index

| | |
|---|------|
| A | |
| Abbreviations..... | 3 |
| Address..... | 21 |
| Alarm | |
| and Warning Messages..... | 25 |
| Words..... | 26 |
| American National Standard..... | 4 |
| Analog Input and Output Objects..... | 14 |
| Assumptions..... | 4 |
| B | |
| Background knowledge..... | 4 |
| BACnet | |
| BACnet..... | 23 |
| (Building Automation and Control Network)..... | 4 |
| cable..... | 10 |
| Device Instance..... | 23 |
| settings..... | 12 |
| Baud rate..... | 21 |
| BIBBs..... | 18 |
| Binary Input and Output Objects..... | 16 |
| Bus Feedback..... | 24 |
| C | |
| Cable | |
| lengths and number of nodes..... | 9 |
| Routing..... | 10 |
| Cabling..... | 9 |
| Coasting Select..... | 22 |
| Communication cable..... | 10 |
| Conformance Classes..... | 4 |
| Control | |
| Site..... | 21 |
| Timeout Time..... | 21 |
| word time-out function..... | 13 |
| Conventions..... | 4 |
| Copyright, limitation of liability and revision rights..... | 5 |
| D | |
| DC current..... | 8 |
| DeviceNet..... | 3 |
| Digital/bus settings..... | 12 |
| Discharge time..... | 6 |
| E | |
| Electrical ratings..... | 8 |
| EMC Precautions..... | 11 |
| F | |
| FC | |
| feedback to network..... | 0 |
| Port Diagnostics..... | 23 |
| port settings..... | 12 |
| Port Settings..... | 21 |
| Function groups..... | 4 |
| Fuses..... | 8 |
| H | |
| High | |
| altitude..... | 7 |
| voltage..... | 6 |
| I | |
| Initialisation procedure..... | 12 |
| L | |
| Leakage current..... | 7 |
| M | |
| Maximum Response Delay..... | 22 |
| Minimum Response Delay..... | 22 |
| Modbus..... | 3 |
| Motor cables..... | 8, 0 |
| Multiple | |
| frequency converters..... | 8 |
| ground shielding..... | 11 |
| N | |
| Network | |
| Connection..... | 10 |
| Frequency Converter Control Inputs and -Outputs..... | 14 |
| O | |
| Object/Property Support Matrix..... | 19 |
| Overcurrent protection..... | 8 |
| P | |
| Parity and Stop Bits..... | 21 |
| PELV..... | 7 |
| PICS..... | 4 |
| Power connection..... | 8 |
| Profibus..... | 3 |
| Protocol..... | 21 |
| Q | |
| Qualified personnel..... | 6 |

S**Set-up example..... 13****Single ground screen..... 11****T****Technical Overview..... 4****Timeout function..... 21****U****Unintended start..... 6****W****Warning Words..... 27****Windmilling..... 7****Wire sizes..... 8**



www.danfoss.com/drives

.....
Danfoss can accept no responsibility for possible errors in catalogues, brochures and other printed material. Danfoss reserves the right to alter its products without notice. This also applies to products already on order provided that such alterations can be made without subsequential changes being necessary in specifications already agreed. All trademarks in this material are property of the respective companies. Danfoss and the Danfoss logotype are trademarks of Danfoss A/S. All rights reserved.
.....

