

■ Contents

Introduction to VLT 2800	3
Software version	3
High voltage warning	4
These rules concern your safety.	4
Warning against unintended start	4
Installation	6
Mechanical dimensions	6
Mechanical installation	10
General information about electrical installation	11
EMC-correct electrical installation	12
Grounding of shielded/armored control cables	13
Diagram	14
Electrical installation	15
Safety clamp	17
Prefuses	17
AC line connection	17
Motor connection	18
Direction of motor rotation	19
Motor thermal protection	19
Parallel connection of motors	19
Motor cables	19
Brake connection	20
Ground connection	20
Load sharing	20
Tightening Torque, Power Terminals	21
Calculation of brake resistance	21
Access to control terminals	21
Electrical installation, control circuitry	21
Tightening torques, control cables	22
Electrical installation, control terminals	22
Relay connection	23
VLT Software Dialog	23
Connection examples	24
Control unit	26
Manual initialization	26
Automatic motor tuning	27
Display readout	29
Hand Auto	29
Warnings/alarms	30
Special conditions	31
Temperature-related switching frequency	31
Derating for long motor cables	31

VLT 2800 start-up	31
Programming	33
Operation & Display	33
Load and Motor	41
References & Limits	52
Inputs and Outputs	59
Special functions	69
Enhanced Sleep Mode	79
Serial communication	84
Technical functions	93
All about VLT 2800	98
Warnings/alarm messages	98
Warning words, extended status words and alarmwords	102
Special conditions	103
Extreme environments	103
Galvanic Isolation (PELV)	103
UL Standard	104
General technical data	105
Technical data, mains supply 1 x 220 - 240 V/3 x 200-240V	110
Technical data, mains supply 3 x 380 - 480 V	111
Available literature	112
Supplied with the unit	112

VLT 2800
Instruction Manual
Software version: 3.1x



This Design Guide can be used for all VLT 2800 series adjustable frequency drives with software version 3.1x. The software version number is indicated in parameter 640.



Warning

It can be extremely dangerous to touch the electrical parts, even when the line supply has been disconnected. Also ensure that other voltage inputs are disconnected from load sharing through the DC bus. Wait at least 4 minutes after the input power has been removed before servicing the drive.

■ High voltage warning

The voltage of the frequency converter is dangerous whenever the converter is connected to mains. Incorrect fitting of the motor or frequency converter may cause damage to the equipment, serious injury or death. Consequently, it is essential to comply with the instructions in this manual as well as local and national rules and safety regulations.



The Protective Extra Low Voltage (PELV) requirements stated in IEC 61800-5-1 are not fulfilled at altitudes above 2000 m (6562 ft.). For 200V frequency converters the requirements are not fulfilled at altitudes above 5000 m (16 404 ft.). Please contact Danfoss Drives for further information.

■ These rules concern your safety.

1. The adjustable frequency drive must be disconnected from AC line if repair work is to be carried out. Ensure that the line supply has been disconnected and that the prescribed time has passed before removing motor and AC line plugs.
2. The [STOP/RESET] key on the control panel of the adjustable frequency drive does not disconnect the equipment from line power and is therefore not to be used as a safety switch.
3. The unit must be properly grounded, the user must be protected against the supply voltage, and the motor must be protected against overloading in accordance with prevailing national and local regulations.
4. The ground leakage currents are higher than 3.5 mA.
5. Protection against motor overload is not included in the factory setting. If this function is required, set parameter 128 *Motor thermal protection* to data value *ETR trip* or data value *ETR warning*. For the North American market: The ETR functions provide overload protec-

tion of the motor, class 20, in accordance with NEC.

6. Do not remove either the plugs for the motor or line supply while the adjustable frequency drive is connected to line power. Ensure that the line supply has been disconnected and that the prescribed time has passed before removing motor and AC line plugs.
7. Note that the adjustable frequency drive has more voltage inputs than L1, L2 and L3 when the DC bus terminals are used. Check that all voltage inputs are disconnected and that the prescribed time has passed before repair work is commenced.

■ Warning against unintended start

1. The motor can be brought to a stop by means of digital commands, bus commands, references or a local stop, while the frequency converter is connected to mains. If personal safety considerations make it necessary to ensure that no unintended start occurs, these stop functions are not sufficient.
2. While parameters are being changed, the motor may start. Consequently, the stop key [STOP/RESET] must always be activated, following which data can be modified.
3. A motor that has been stopped may start if faults occur in the electronics of the frequency converter, or if a temporary overload or a fault in the supply mains or the motor connection ceases.

■ Motor overload protection

The electronic thermal relay (ETR) in UL listed VLTs provides Class 20 motor overload protection in accordance with the NEC in single motor applications when parameter 128 is set for "ETR TRIP" and pa-

parameter 105 *Motor current* is set for the rated motor current.

**Warning**

It can be extremely dangerous to touch the electrical parts, even when the line supply has been disconnected. Also ensure that other voltage inputs are disconnected from load sharing through the DC bus. Wait at least 4 minutes after the input power has been removed before servicing the drive.

VLT® 2800 Series

■ **Mechanical dimensions**

The drawings below describe the mechanical dimensions. All dimensions are given in mm.



NOTE

Please note that all filter options must be vertically mounted.

VLT 2803-2815 200-240 Volt
VLT 2805-2815 380-480 Volt

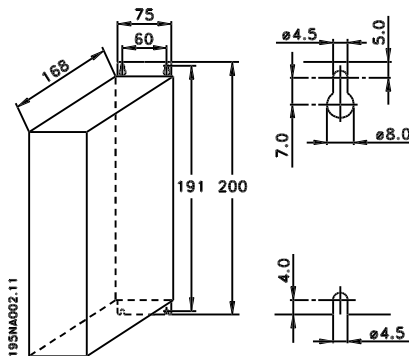

VLT 2822 220 - 240 V, PD2
VLT 2840 200 - 240 Volt
VLT 2855-2875 380 - 480 Volt

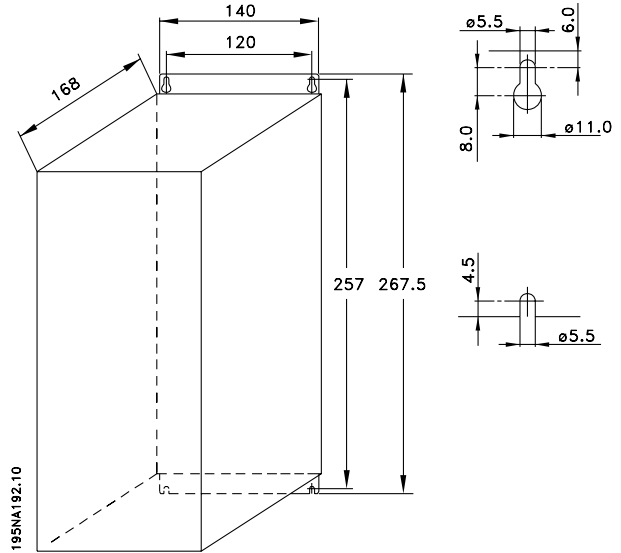

The drawing below gives the mechanical dimensions of VLT 2822 (3 HP) 200-240 Volts and VLT 2822-2840 (3 - 5 HP) 380-480 Volts. All dimensions are in inches.

VLT 2822 200-240 Volt
VLT 2822-2840 380-480 Volt

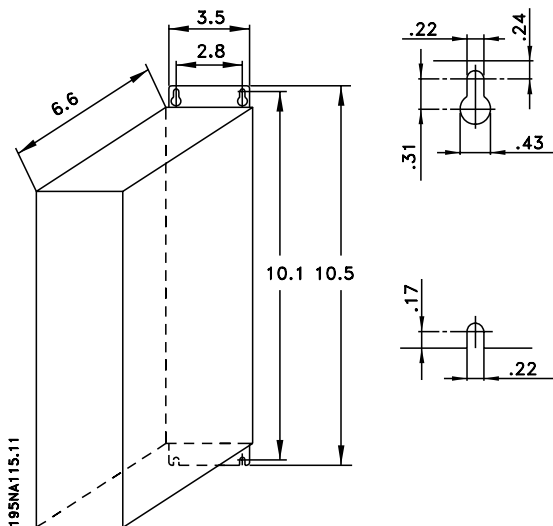

VLT 2840 220 - 240 V, PD2
VLT 2880-82 380 - 480 V

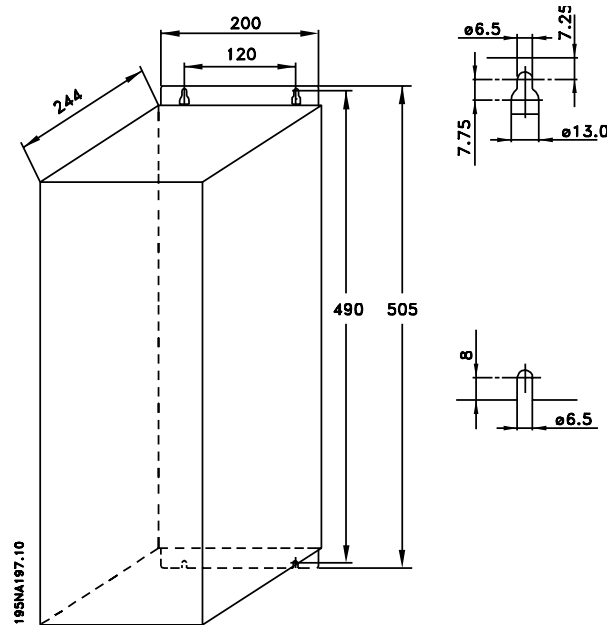

VLT® 2800 Series

■ Motor coils (195N3110)

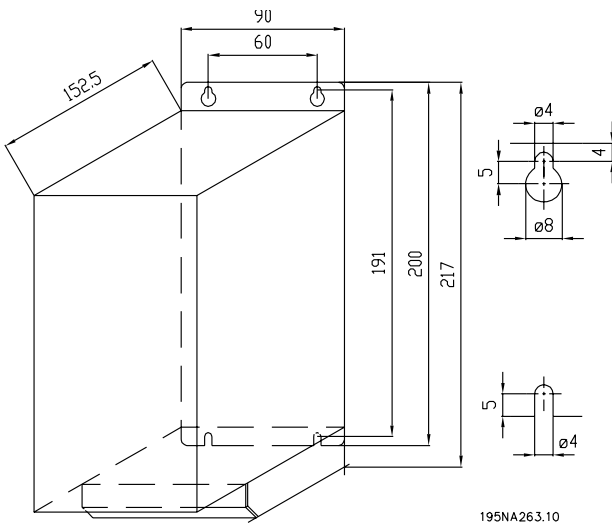

■ Terminal cover

The drawing below gives the dimensions for NEMA 1 terminal covers for VLT 2803-2875.

Dimension 'a' depends on the unit type.

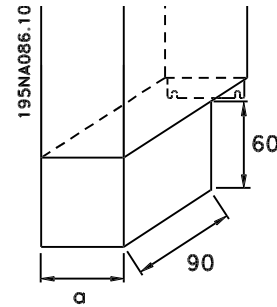

■ RFI 1B filter (195N3103)

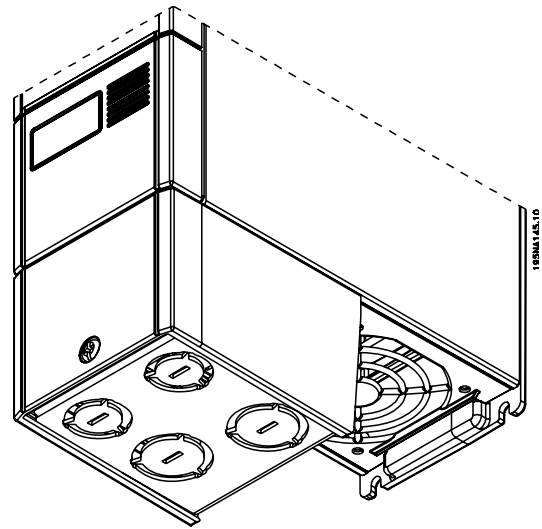
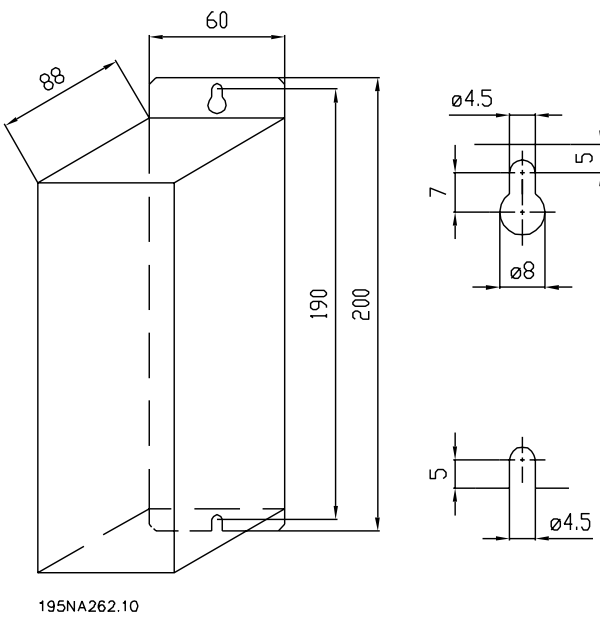

■ IP 21 solution

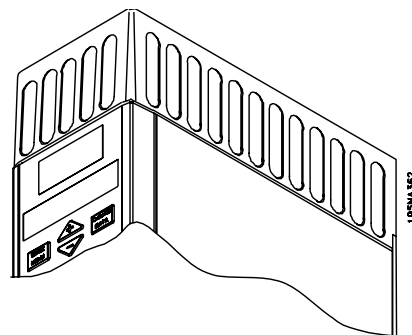

VLT® 2800 Series

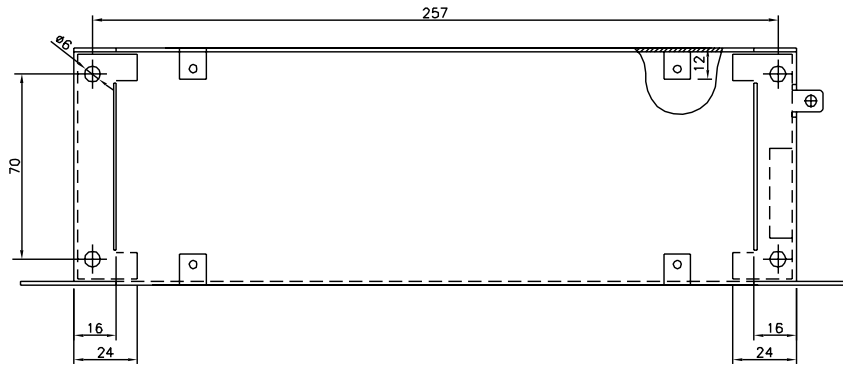
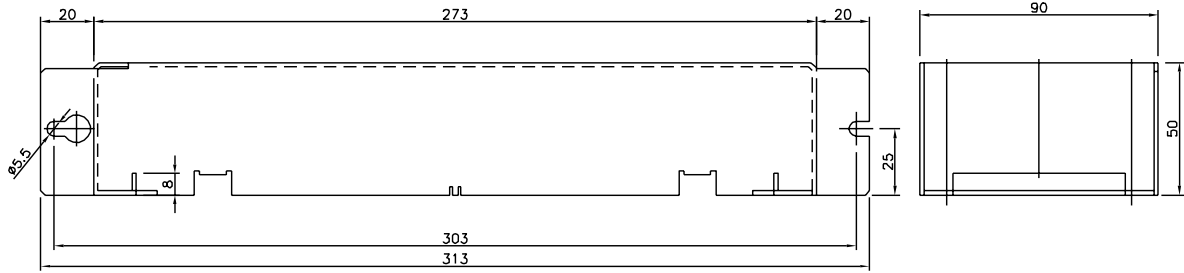

195NA358.10

192H4720

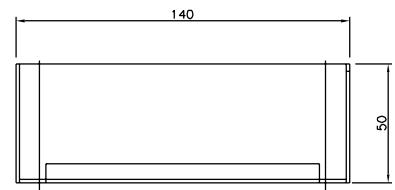
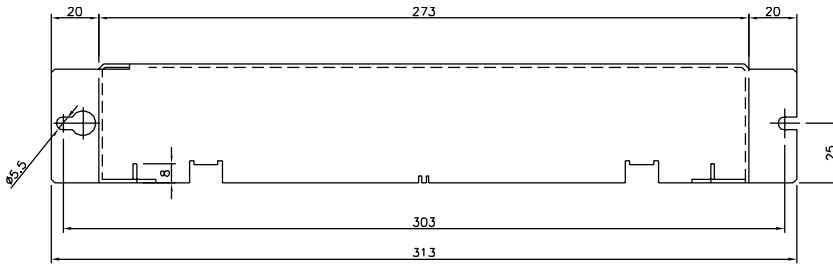

195NA359.10

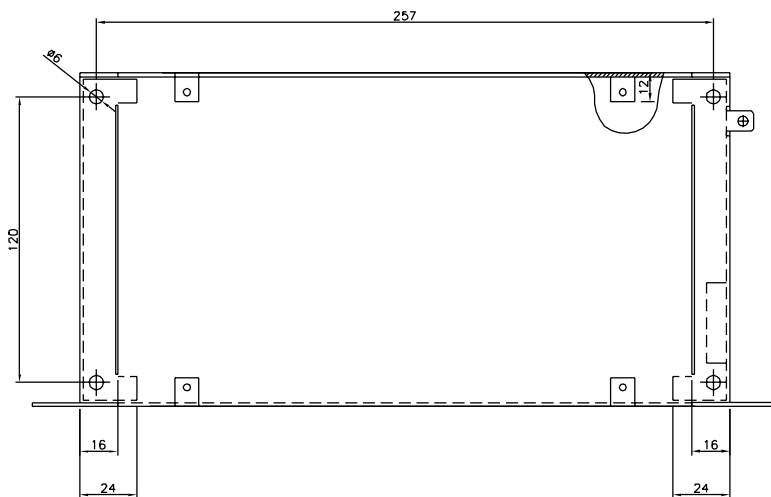

192H4893

Installation

■ Mechanical installation

The adjustable frequency drive is cooled by air circulation. For proper cooling, allow a minimum of 4 inches (100 mm) of open space above and below the unit. To protect the unit from overheating, ensure that both the ambient temperature and the 24-hour average temperature are not exceeded. The maximum temperature and 24-hour average are listed in *General technical data* in this manual. If the ambient temperature is in the range of 113°F - 131°F (45°C - 55°C), derating of the drive must be carried out. See *Derating for ambient temperature* in this manual. The service life of the unit will be reduced without applicable derating.



The requirements that apply to enclosures and remote mounting must be complied with to avoid serious injury or equipment damage, especially when installing large units.

■ Enclosures

In the USA and some other countries, a NEMA 1 terminal cover enclosing terminal connectors is required if the drive is not installed within another enclosure.

■ Spacing for mechanical installation

All units require a minimum of 4 in of air from other components above and below the enclosure.

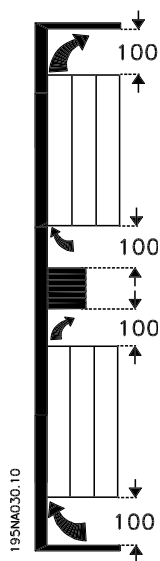

■ Side-by-side

All VLT 2800 units can be installed side-by-side and in any position, as the units do not require ventilation on the side.

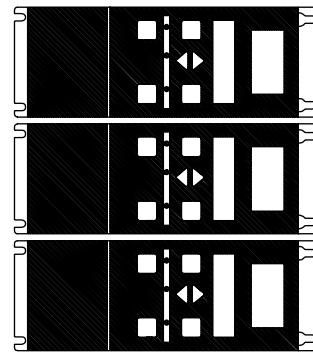
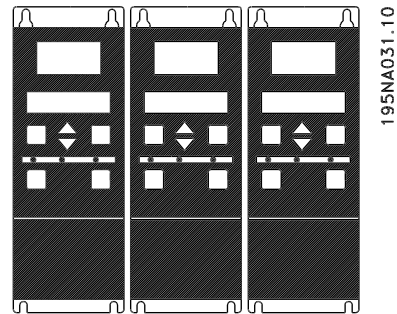

195NA0147.10



NOTE

With the IP 21 solution all units require a minimum of 4 in air on each side. This means that side-by-side mounting is not allowed.

■ **General information about electrical installation**

■ **High voltage warning**



The voltage of the adjustable frequency drive is dangerous whenever the drive is connected to the AC line. Incorrect installation of the motor or drive may cause damage to the equipment, serious injury or death. Comply with the safety instructions in this manual as well as local and national rules and safety regulations. Touching electrical parts may be fatal - even after the equipment has been disconnected from the AC line. Wait at least 4 minutes for current to dissipate.



NOTE

It is the responsibility of the user or installer to ensure correct grounding and protection in accordance with national and local standards.

■ **Earthing**

Comply with the following at installation:

- Safety earthing: The drive has a high leakage current and must be earthed properly for safety. Follow all local safety regulations.
- High frequency earthing: Keep earthing connections as short as possible.

Connect all earthing SYSTEMs to ensure the lowest possible conductor impedance. The lowest possible conductor impedance is achieved by keeping the conductor as short as possible and by grounding with the greatest possible surface area. If multiple drives are installed in a cabinet, the cabinet backplate, which must be made of metal, should be used as a joint earth reference plate. The drives must be fitted to the backplate at the lowest possible impedance.

To achieve low impedance, connect the drive to the backplate with the drive fastening bolts. Remove all paint from the contact points.

■ **High voltage test**

A high voltage test can be performed by short-circuiting terminals U, V, W, L1, L2 and L3, and applying a max. of 2,160 V DC in 1 sec. between this short-circuit and terminal 95.



Do not perform a high voltage test between the control terminals and the chassis, because the voltage potential of the control card cannot exceed approximately 100 volts with respect to chassis due to a voltage limiting circuitry. The terminals are protected against direct hazardous access through barriers.

■ EMC-correct electrical installation

General points to be observed to ensure EMC-correct electrical installation.

- Use only shielded/armoured motor cables and shielded/armoured control cables.
- Connect the screen to ground at both ends.
- Avoid installation with twisted shield ends (pigtailed), since this ruins the shielding effect at high frequencies. Use cable clamps instead.
- It is important to ensure good electrical contact from the installation plate through the installation screws to the metal cabinet of the variable frequency drive.
- Use starwashers and galvanically conductive installation plates.
- Do not use unshielded/unarmoured motor cables in the installation cabinets.

The illustration below shows EMC-correct electrical installation, in which the variable frequency drive has been fitted in an installation cabinet and connected to a PLC.

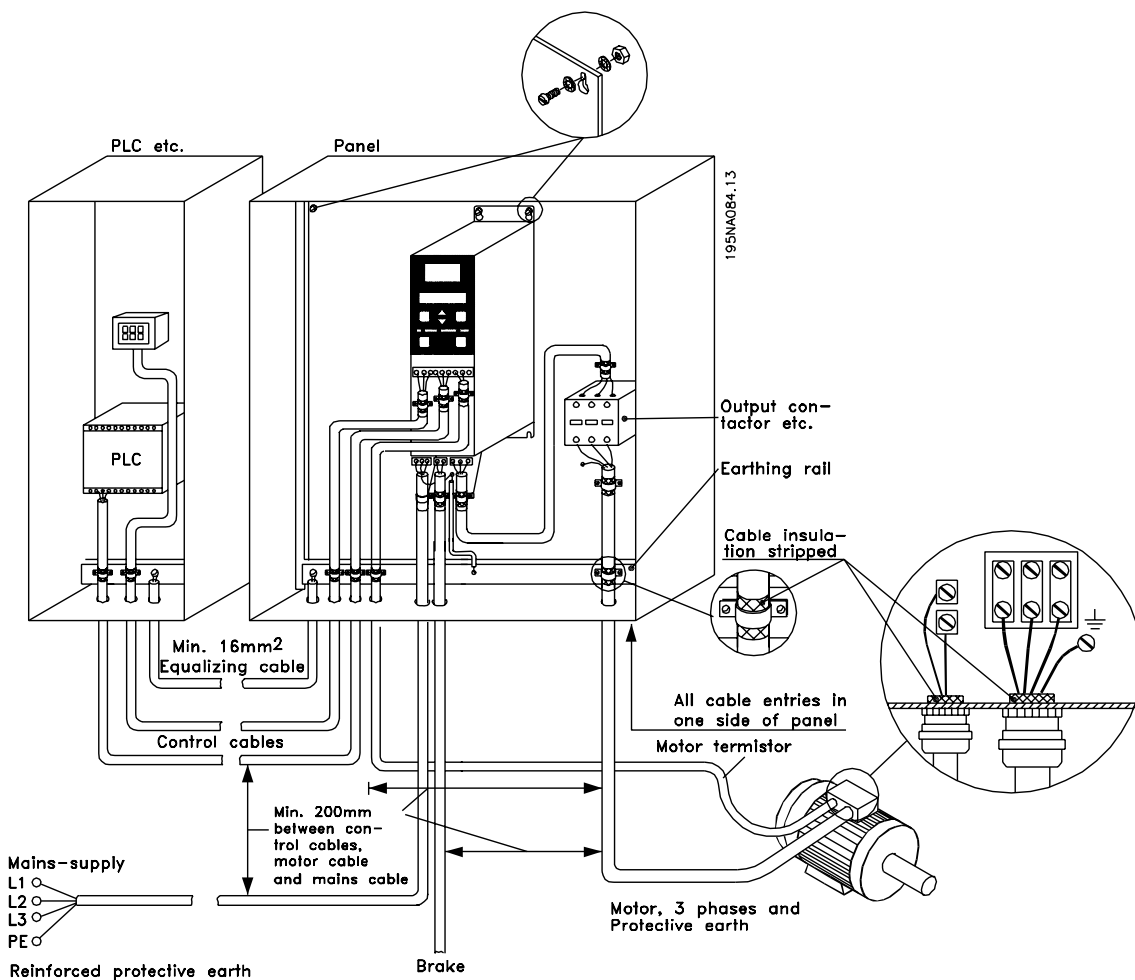

VLT® 2800 Series

■ **Grounding of shielded/armored control cables**

In general, control cables must be shielded/armored, and the shield must be connected to the unit's metal cabinet with a cable clamp at each end.

The drawing below shows the correct way to perform the grounding, and what to do when in doubt.

1. **Correct grounding**
Control cables and cables for serial communication must be attached with cable clamps at both ends to ensure the maximum possible electrical contact.
2. **Incorrect grounding**
Do not use twisted shield ends that are plaited together (pigtailed), as these increase shield impedance at higher frequencies.
3. **Protection with respect to ground potential between the PLC and VLT**
If the ground potential between the VLT adjustable frequency drive and the PLC, etc. is different, electric noise may occur that will disturb the whole system. This problem can be solved by fitting an equalizing cable next to the control cable. Minimum cable cross-section: 0.025 in² [16 mm²].
4. **In the event of a 50/60 Hz ground loop**
If very long control cables are used, 50/60 Hz ground loops can arise, and these can interfere with the whole system. This problem is resolved by attaching one end of the shield to the ground via a 100 nF capacitor (short pin length).

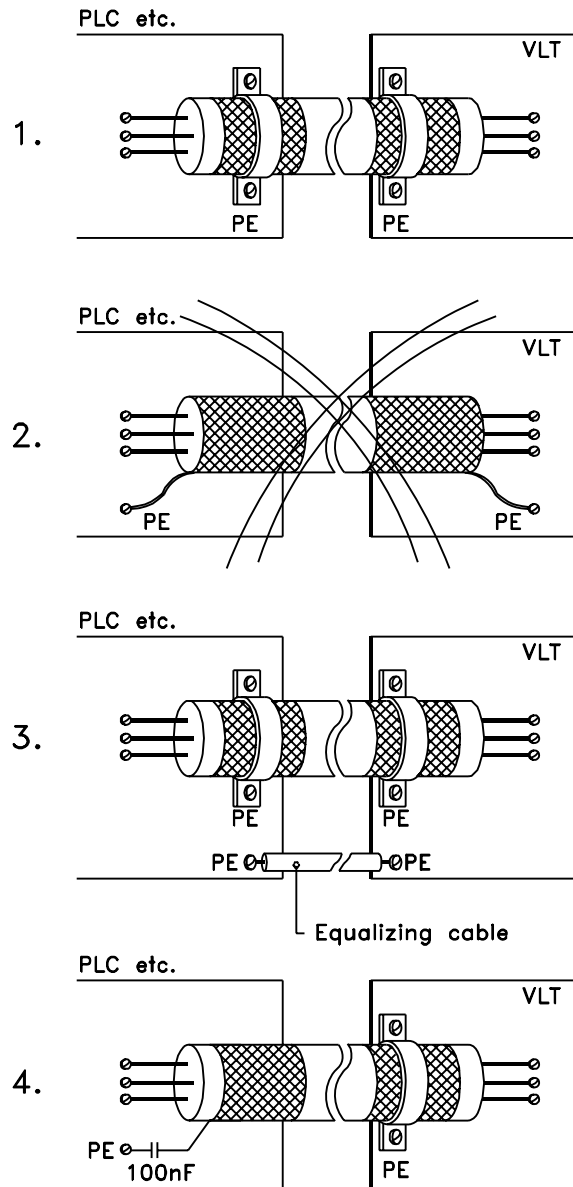

195NA100.12

Installation

■ Diagram

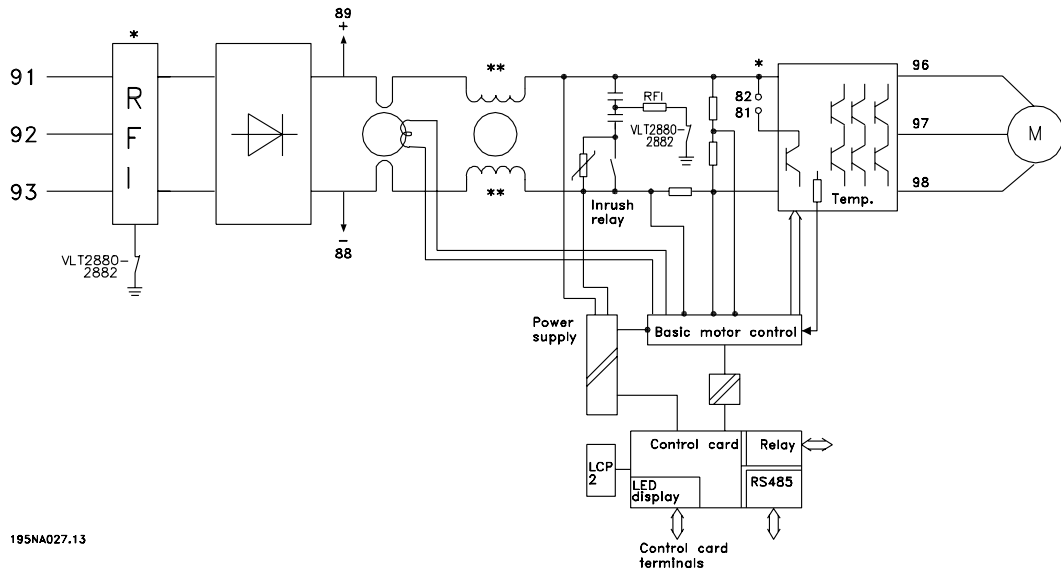

195NA027.13

- * Integrated 1A RFI filter and brake is an option.
- ** VLT 2803-2815 200-240 V is not supplied with intermediate circuit coils.

■ Electrical installation

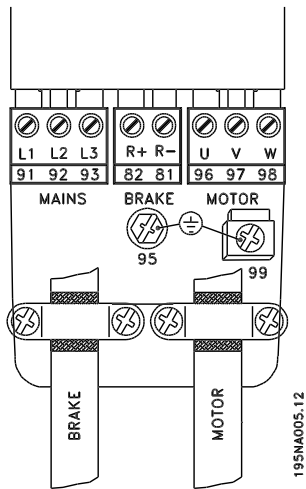

See also the section Brake Connection.

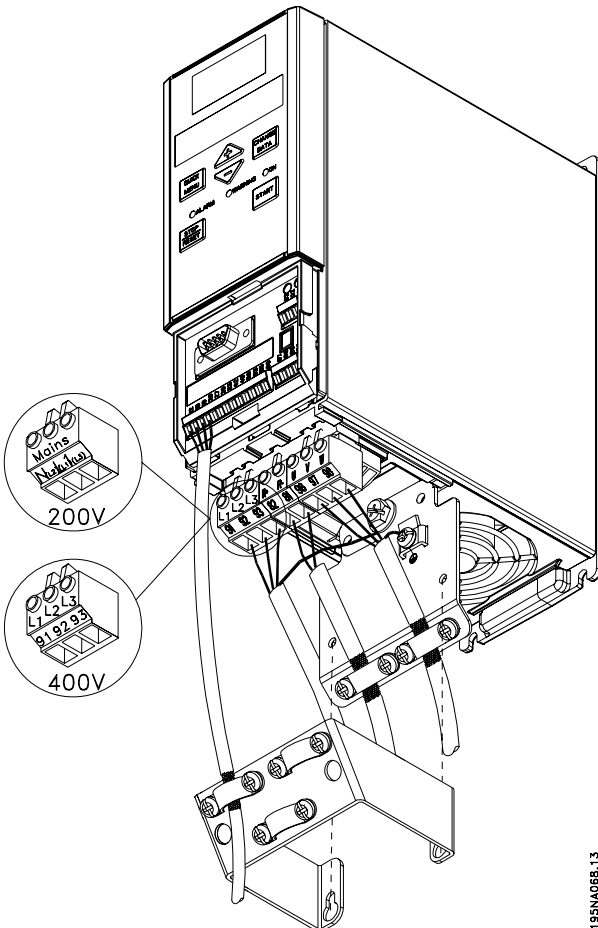

VLT 2803-2815 200-240 V, 2805-2815 380-480 V

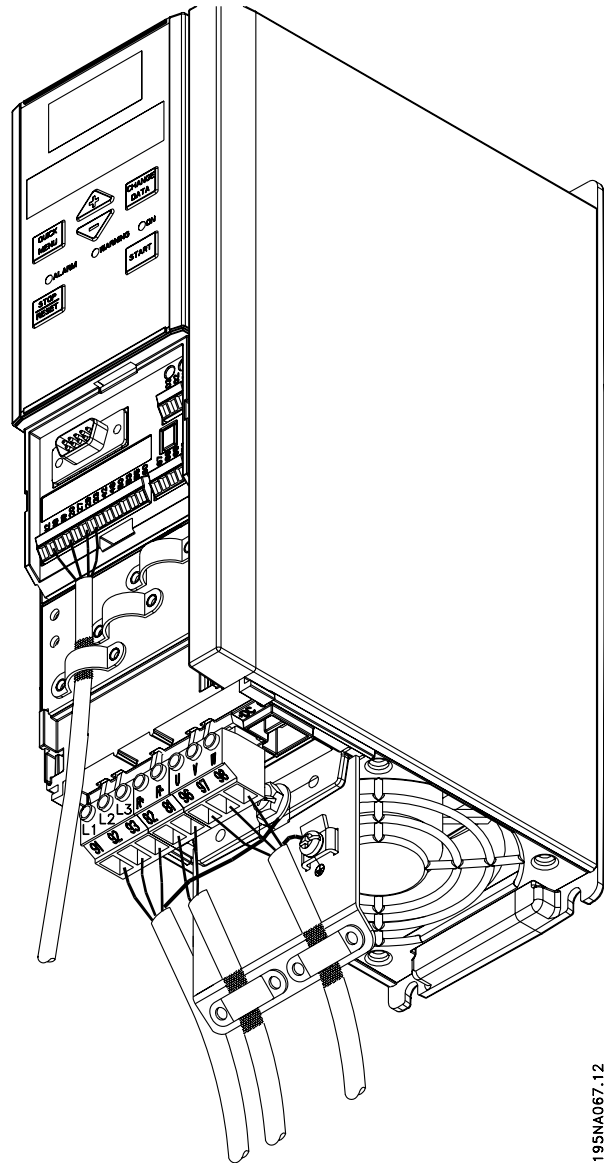

VLT 2822 200-240 V, 2822-2840 380-480 V

Installation

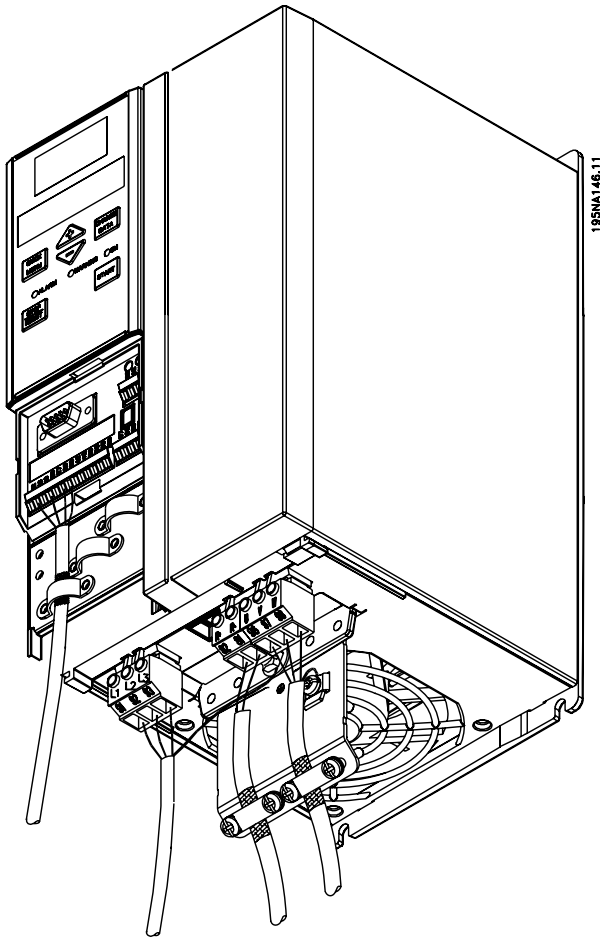

VLT 2840 200-240 V, VLT 2822 PD2, 2855-2875
380-480 V

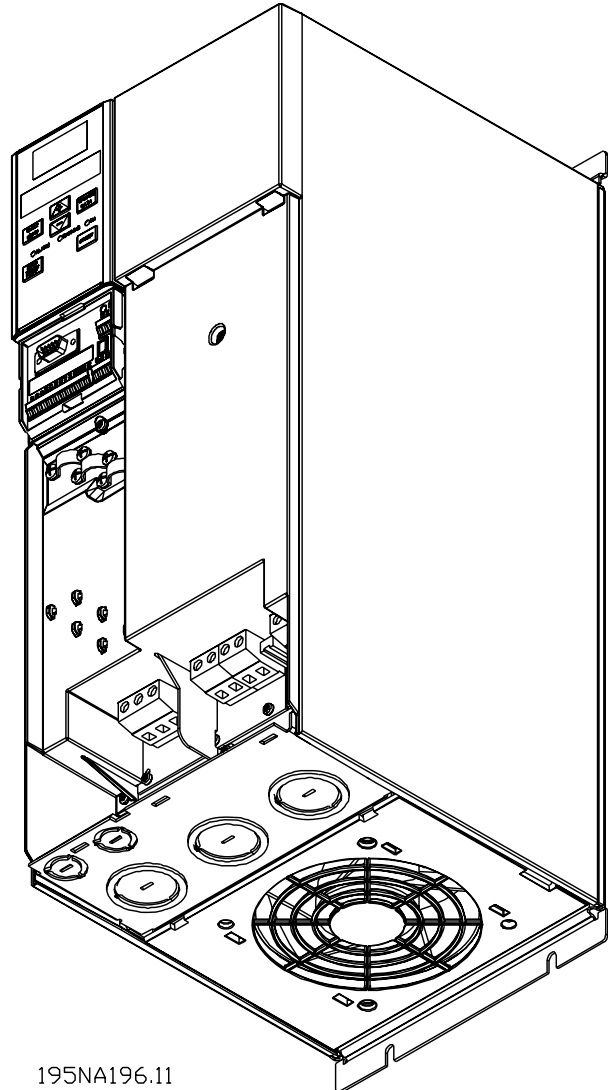

VLT 2880-2882 380-480 V, VLT 2840 PD2

Please note that the units will be supplied with two bottom plates, one for metric glands and one for conduits.

VLT® 2800 Series

■ Safety clamp

To maintain the galvanic isolation (PELV) between the control terminals and high-voltage terminals, the accompanying safety clamp must be attached to VLT 2803-2815, 200-240 V, and VLT 2805-2815, 380-480 V. Attach the safety clamp to the strain relief plate with the two screws provided.

For all unit types, external prefuses must be fitted in the line supply to the adjustable frequency drive. For UL/cUL applications with a line voltage of 200-240 Volt, use prefuses type Bussmann KTN-R (200-240 Volt) or Ferraz Shawmut type ATMR (max. 30A). For UL/cUL applications with a line voltage of 380-480 Volt, use prefuses type Bussmann KTS-R (380-480 Volt).

■ Prefuses

Prefuses for UL application /cUL

Alternative fuses 380-500 V drives

VLT 2800	Bussmann E52273	Bussmann E4273	Bussmann E4273	Bussmann E4273	Bussmann E4273	Bussmann E4273	SIBA E180276	Little Fuse E81895	Ferraz-Shawmut E163267/ E2137	Ferraz-Shawmut E163267/ E2137
2805-2820	RK1/JDDZ KTS-R20	J/JDDZ JKS-20	T/JDDZ JJS-20	CC/JDDZ FNQ-R-20	CC/JDDZ KTK-R-20	CC/JDDZ LP-CC-20	RK1/JDDZ 5017906-02 0	RK1/JDDZ KLS-R20	CC/JDDZ ATM-R25	RK1/JDDZ A6K-20R
2855-2875	KTS-R25	JKS-25	JJS-25				5017906-02 5	KLS-R25	ATM-R20	A6K-25R
2880-2882	KTS-R50	JKS-50	JJS-50				5014006-05 0	KLS-R50	-	A6K-50R

Alternative Fuses 200-240 V drives

VLT 2800	Bussmann E52273	Bussmann E4273	Bussmann E4273	SIBA E180276	Little Fuse E81895	Ferraz-Shawmut E163267/ E2137	Ferraz-Shawmut E163267/ E2137
2803-2822	RK1/JDDZ KTN-R20	J/JDDZ JKS-20	T/JDDZ JJN-20	RK1/JDDZ 5017906-02 0	RK1/JDDZ KLS-R20	CC/JDDZ ATM-R25	RK1/JDDZ A6K-20R
2840	KTN-R25	JKS-25	JJN-25	5017906-02 5	KLS-R25	ATM-R20	A6K-25R

■ AC line connection



All drives that are equipped with an RFI filter cannot be connected to a grounded DELTA or IT mains/AC line system.



NOTE

Check that the AC voltage matches the voltage rating of the drive. The drive rating is on the drive nameplate. See *Technical data* in this manual for correct dimensioning of cable cross-section.

For single phase 220-240 Volts input, attach the neutral wire to terminal N (L₂) and connect the phase wire to terminal L1 (L₁).

No	N(L ₂) L1(L ₁) (L ₃)	AC line voltage 1 x 220-240 V
.	N L1	
No	95	Ground connection
.		

No	N(L ₂) L1(L ₁) (L ₃)	AC line voltage 3 x 220-240 V
.	L2 L1 L3	
No	95	Ground connection
.		
No	91 92 93	AC line voltage 3 x 380-480 V
.	L1 L2 L3	
No	95	Ground connection
.		



380-460 Volt units with RFI-filters may not be connected to AC line supplies in which the voltage between phase and ground is more than 300 Volts. Please note that for the AC line for IT and the delta ground the AC line voltage can exceed 300 Volts between phase and ground. Units with type code R5 can be connected

to mains supplies with up to 400 V between phase and ground.

See *Technical data* for correct dimensioning of cable cross-section.

■ **Motor connection**

Connect the motor to terminals 96, 97, 98. Connect ground to terminal 99.

No.	96 97 98	Motor voltage 0-100% of line voltage.
	U V W	3 wires of motor
	U1 V1 W1 W2 U2 V2	6 wires out of motor, Delta-connected
	U1 V1 W1	6 wires out of motor, Star-connected U2, V2, W2 to be interconnected separately (optional terminal block)
No.	PE	Ground connection

See *Technical data* for correct dimensioning of cable cross-section.

All types of three-phase asynchronous standard motors can be connected to an adjustable frequency drive. Normally, small motors are star-connected (230/400 V, Δ / Y), while large motors are delta-connected (400/690 V, Δ / Y). The correct connection mode and voltage can be read from the motor nameplate.



NOTE

In motors without phase insulation paper, an LC filter should be fitted on the output of the adjustable frequency drive.

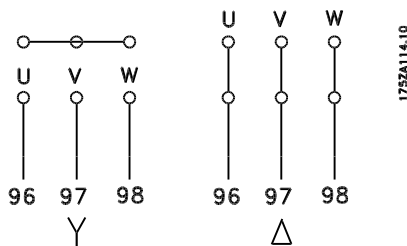

■ Direction of motor rotation

To change the direction of motor rotation, switch any two phases at the drive output or at motor terminals.

■ Motor thermal protection

The electronic thermal relay in UL approved variable frequency drives has received the UL approval for single motor protection, when parameter 128 *Motor thermal protection* has been set for *ETR Trip* and parameter 105 *Motor current, I_{M,N}* has been programmed to the rated motor current (see motor nameplate).

■ Parallel connection of motors

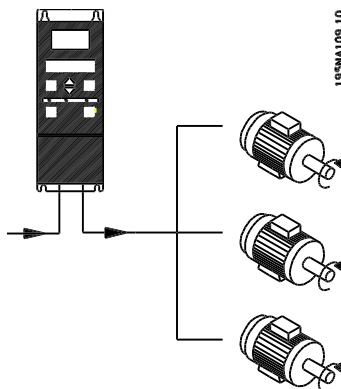

The adjustable frequency drive is able to control several motors connected in parallel. If the motors are to have different rpm values, use motors with different rated rpm values. Motor rpm is changed simultaneously, which means that the ratio between the rated rpm values is maintained across the range. The total current consumption of the motors is not to exceed the maximum rated output current I_{INV} for the adjustable frequency drive.

Problems may arise at the start and at low rpm values if the motor sizes are widely different. This is because the small motors' relatively high ohmic resistance in the stator calls for a higher voltage at the start and at low rpm values.

In systems with motors connected in parallel, the electronic thermal relay (ETR) of the adjustable frequency drive cannot be used as motor protection for the individual motor. For this reason, further motor protection must be used, such as thermistors in each motor or an individual thermal relay, for example (circuit breakers are not a suitable means of protection).



NOTE

Parameter 107 *Automatic motor adaptation, AMT* cannot be used when motors are connected in parallel. Parameter 101 *Torque characteristic* must be set to *Special motor characteristics* [8] when motors are connected in parallel.

■ Motor cables

See Technical data for correct dimensioning of motor cable cross-section and length. Always comply with national and local regulations on cable cross-section.



NOTE

If an unshielded/unarmored cable is used, some EMC requirements are not complied with, see *EMC test results* in the Design Guide.

If the EMC specifications regarding emissions are to be complied with, the motor cable must be shielded/armored unless otherwise stated for the RFI filter in question. It is important to keep the motor cable as short as possible so as to reduce the noise level and leakage currents to a minimum. The motor cable shield must be connected to the metal cabinets of the adjust-

VLT® 2800 Series

able frequency drive and the motor. The shield connections are to be made with the largest possible surface area (cable clamp). This is enabled by different installation devices in different adjustable frequency drives. Connecting with twisted shield ends (pigtails) is to be avoided, as these spoil the shielding effect at high frequencies. If it is necessary to break the shield to install a motor isolator or motor relay. The shield must be continued at the lowest possible HF impedance.

■ Brake connection



NOTE

Voltages up to 850 VDC occur on the terminals.

No.	81	82	Brake resistor
	R-	R+	terminals

Connect the brake resistor wiring to drive terminals 81 and 82. The connection cable to the brake resistor must be shielded/armored. Connect the shield to both the ground of the drive and the brake resistor by means of cable clamps. Dimension the cross-section of the brake cable to match the brake torque.

■ Ground connection

Since the leakage currents to ground may be higher than 3.5 mA, the adjustable frequency drive must always be connected to ground in accordance with applicable national and local regulations. To ensure that the ground cable has good mechanical connection to terminal 95, the cable cross section must be a minimum 7 AWG (10 mm²). To improve protection even further, a Residual Current Device (RCD) can be fitted to ensure that the adjustable frequency drive cuts out when the leakage currents get too high. Also see RCD Application note MN.90.GX.02.

■ Load sharing

Load sharing provides the facility to connect several frequency converters' DC intermediate circuits. This requires that the installation is extended using extra fuses and AC coils (see drawing below). For load sharing parameter 400 *Brake function* must be set to *Load sharing* [5].

Use 6.3 mm Faston Plugs for DC (Load Sharing).

Contact Danfoss or see instructions no. MI.50.NX.02 for further information.

No.	88	89	Loadsharing
	-	+	

175ZA299.12

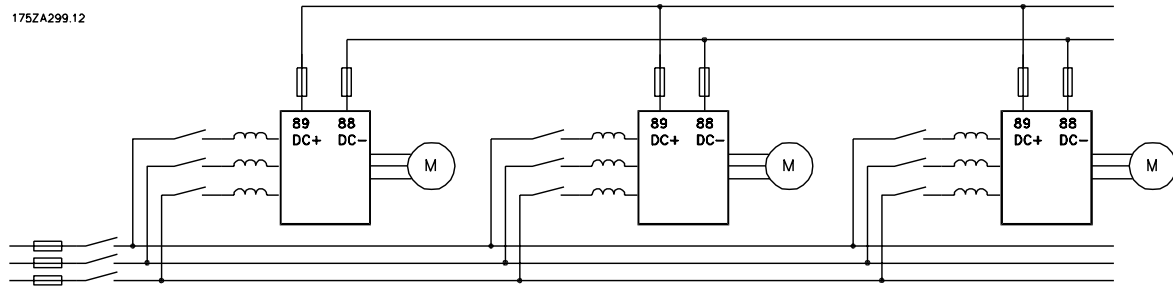

Note that voltage levels of up to 850 V DC may occur between terminals 88 and 89.

■ Tightening Torque, Power Terminals

Power and ground terminals must be tightened with the following torques:

VLT	Terminals	Torque [Nm]
2803-2875	Power AC line brake	0.5-0.6
	Ground	2-3
2880-2882, 2840 PD2	Power AC line brake	1.2-1.5
	Ground	2-3

■ Calculation of brake resistance

In lifting/lowering applications you need to be able to control an electromagnetic brake. The brake is controlled using a relay output or digital output (terminal 46). The output must be kept closed (voltage-free) for the period of time during which the variable frequency drive is not able to 'support' the motor, for example due to the load being too great. Select *Mechanical brake control* in parameter 323 or 341 for applications with an electromagnetic brake.

When the output frequency exceeds the brake cut out value set in par. 138, the brake is released if the motor current exceeds the preset value in parameter 140. When stopping the brake is engaged when the output frequency is less than the brake engaging frequency, which is set in par. 139.

If the variable frequency drive is placed at alarm status or in an overvoltage situation the mechanical brake is cut in immediately.



NOTE

This application is only for lifting/lowering without a counterbalance.

■ Access to control terminals

All control terminals are located underneath the protective plate on the front of the adjustable frequency drive. Remove the protective plate by sliding it downwards (see drawing).

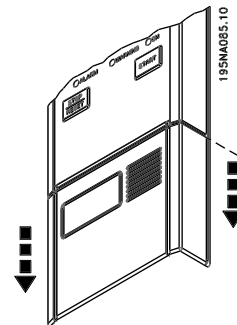

■ Electrical installation, control circuitry



NOTE

Using unshielded/unarmored cable may not comply with some EMI/RFI requirements.

VLT® 2800 Series

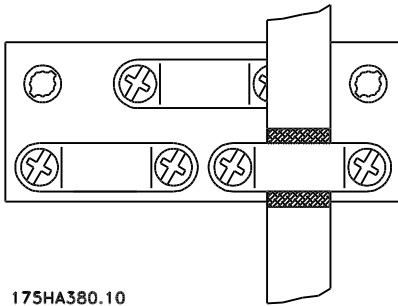

175HA380.10

Control wires must be shielded/armored. Connect the shield to the drive chassis with a clamp. Normally, the

shield must also be connected to the chassis of the controlling device. (See the instructions for the specific device.) In analog signals or connections using very long wires, 50/60 Hz ground loops may occur because of noise transmitted from the AC line. It may be necessary to break the shield and insert a 100 µF capacitor between the shield and the chassis.

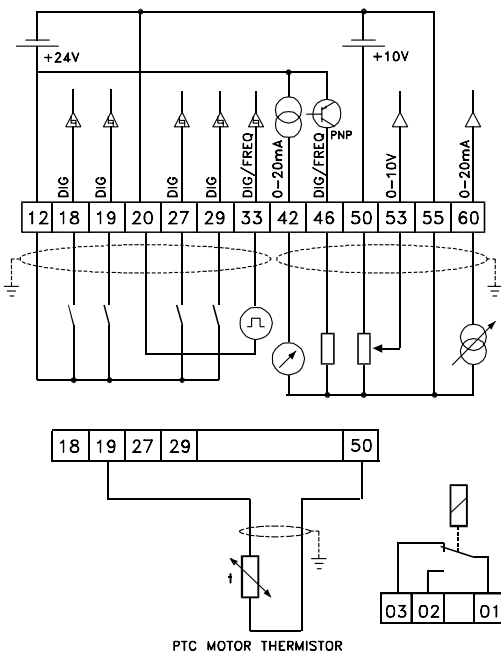

195NA028.14

PTC MOTOR THERMISTOR

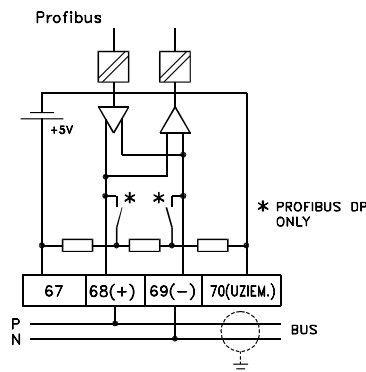
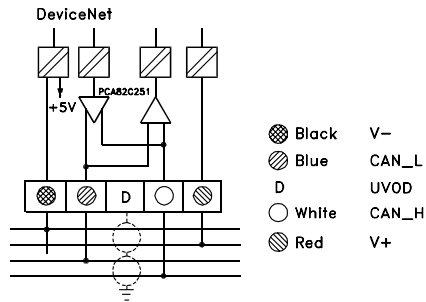

■ Tightening torques, control cables

Control wires must be connected with a tightening torque of 0.22-0.25 Nm.

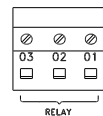

RELAY

■ Electrical installation, control terminals

See section entitled *Grounding of shielded/armored control cables* in the VLT 2800 Design Guide for the correct termination of control cables.

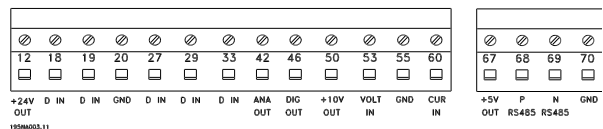

No.	Function
01-03	Relay outputs 01-03 can be used for indicating status and alarms/warnings.
12	24 V DC voltage supply.
18-33	Digital inputs.
20, 55	Common frame for input and output terminals.
42	Analog output for displaying frequency, reference, current or torque.
46 ₁	Digital output for displaying status, warnings or alarms, as well as frequency output.
50	+10 V DC supply voltage for potentiometer or thermistor.
53	Analogue voltage input 0-10 V DC.
60	Analogue current input 0/4 - 20 mA.
67 ₁	+ 5 V DC supply voltage to Profibus.
68, 69 ₁	RS-485, Serial communication.
70 ₁	Frame for terminals 67, 68 and 69. Normally, this terminal is not to be used.

1. The terminals are not valid for DeviceNet/CANopen. See also the DeviceNet manual, MG.90.BX.YY for further details.

■ Relay connection

See parameter 323 *Relay output* for programming of relay output.

Nr.	01 - 02	1 - 2 make (normally open)
	01 - 03	1 - 3 break (normally closed)



NOTE

Please note that the cable jacket for the relay must cover the first row of control card terminals - otherwise the galvanic isolation (PELV) cannot be maintained. Max. cable diameter: 4 mm. See drawing.

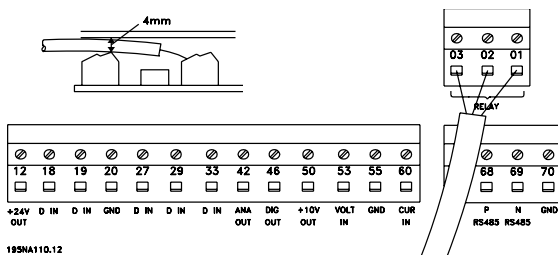

■ Profibus DIP switches setting

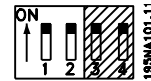

The dip switch is only on the control card with Profibus DP communication. The switch position shown is the factory setting. Switches 1 and 2 are used as cable termination for the RS-485 interface. If the adjustable frequency drive is located as the first or last (or only) unit in the bus system, switches 1 and 2 must be ON. On the remaining adjustable frequency drives, switches 1 and 2 must be OFF. Switches 3 and 4 are not applied.

■ VLT Software Dialog

Connection to terminals 68-70 or Sub D:

- PIN 3 GND
- PIN 8 P-RS 485
- PIN 9 N-RS 485

■ Sub D plug

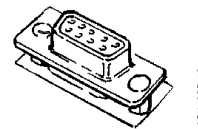

An LCP 2 control unit can be connected to the Sub D plug on the control card. Ordering number: 175N0131. The LCP control unit with ordering number 175Z0401 is not to be connected.

■ Connection examples

■ Start/stop

Start/stop using terminal 18 and coasting stop using terminal 27.

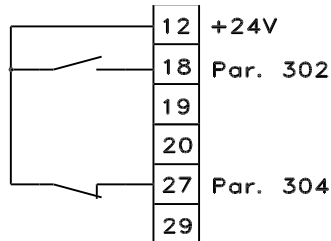

195NA011.11

Par. 302 Digital input = Start [7]

Par. 304 Digital input = Coasting stop inverted [2]

For Precise start/stop the following settings are made:

Par. 302 Digital input = Precise start/stop [27]

Par. 304 Digital input = Coasting stop inverted [2]

■ Pulse start/stop

Pulse start using terminal 18 and pulse stop using terminal 19. In addition, the jog frequency is activated via terminal 29.

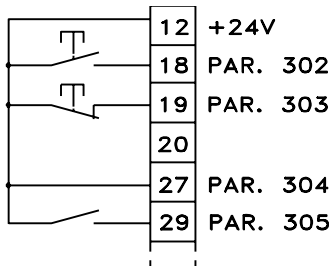

195NA012.11

Par. 302 Digital input = Pulse start [8]

Par. 303 Digital input = Stop inverted [6]

Par. 304 Digital input = Coasting stop inverted [2]

Par. 305 Digital input = Jog [13]

■ Speed up/slow down

Speed up/slow down using terminals 29/33.

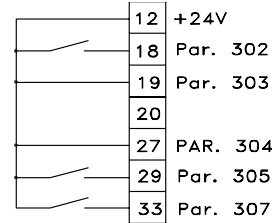

195NA249.10

Par. 302 Digital input = Start [7]

Par. 303 Digital input = Freeze reference [14]

Par. 305 Digital input = Speed up [16]

Par. 307 Digital input = Slow down [17]

■ Potentiometer reference

Voltage reference via a potentiometer.

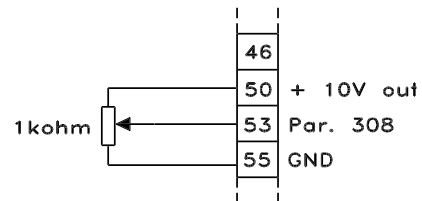

195NA016.10

Par. 308 Analog input = Reference [1]

Par. 309 Terminal 53, min. scaling = 0 Volt

Par. 310 Terminal 53, max. scaling = 10 Volt

■ Connection of a 2-wire transmitter

Connection of a 2-wire transmitter as feedback to terminal 60.

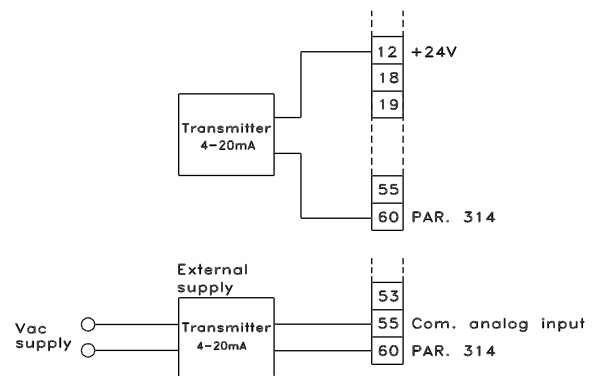

195NA013.11

Par. 314 *Analog input = Feedback [2]*

Par. 315 *Terminal 60, min. scaling = 4 mA*

Par. 316 *Terminal 60, max. scaling = 20 mA*

■ Control unit

On the front of the variable frequency drive there is a control panel.

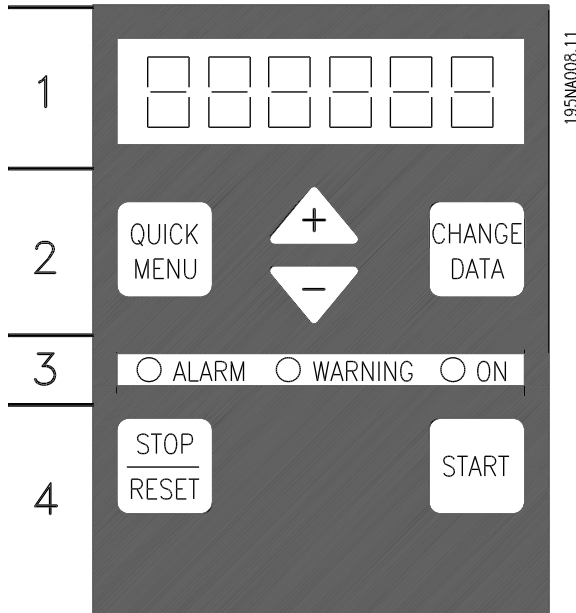

The control panel is divided into five functional groups:

1. Status LED
2. Keys for changing parameters and shifting display function.
3. LEDs.
4. Keys for local operation.

All displays of data are in the form of a six-digit LED display capable of showing one item of operating data continuously during normal operation. As a supplement to the display, there are three LEDs for indication of electrical connection (ON), warning (WARNING) and alarm (ALARM). Most of the variable frequency drive's parameter Setups can be changed immediately via the control panel, unless this function has been programmed as *Locked* [1] via parameter 018 *Lock for data changes*.

■ Control keys

[QUICK MENU] allows access to the parameters used for the Quick menu.

The **[QUICK MENU]** key is also used if a change to a parameter value is not to be implemented.

See also **[QUICK MENU] + [+]**.

[CHANGE DATA] is used for changing a setting.

The **[CHANGE DATA]** key is also used for confirming a change of parameter settings.

[+] / [-] are used for selecting parameters and for changing parameter values.

These keys are also used in Display mode for selecting the display of an operating value.

The **[QUICK MENU] + [+]** keys must be pressed at the same time to give access to all parameters. See *Menu mode*.

[STOP/RESET] is used for stopping the connected motor or for resetting the variable frequency drive after a trip.

Can be selected as *Active* [1] or *Not active* [0] via parameter 014 *Local stop/reset*. In Display mode, the display will flash if the stop function is activated.



NOTE

If the **[STOP/RESET]** key is set at *Not active* [0] in parameter 014 *Local stop/reset*, and there is no stop command via the digital inputs or serial communication, the motor can only be stopped by disconnecting the electrical voltage to the variable frequency drive.

[START] is used for starting the variable frequency drive. It is always active, but the **[START]** key cannot override a stop command.

■ Manual initialization

To manually initialize the adjustable frequency drive to factory default settings, first disconnect AC line voltage. Hold the **[QUICK MENU]** and **[+]** and **[CHANGE DATA]** keys down while simultaneously reconnecting the AC line voltage. Release the keys. The drive has now been programmed for factory settings.

■ Display readout states
Display mode

In normal operation, one item of operating data can be displayed continuously at the operator's discretion. By means of the [+/-] keys, the following options can be selected in Display mode:

- Output frequency [Hz]
- Output current [A]
- Output voltage [V]
- Intermediate circuit voltage [V]
- Output power [kW]
- Scaled output frequency $f_{out} \times p008$

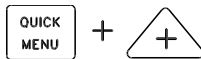
Menu mode

In order to enter the Menu mode, [QUICK MENU] + [+] must be activated at the same time.

In Menu mode, most of the adjustable frequency drive parameters can be changed. Scroll through the parameters using the [+/-] keys. While scrolling in the Menu mode proceeds, the parameter number will flash.

The display shows that the setting in parameter 102 *Motor power* $P_{M,N}$ is 0.75. In order to change the value of 0.75, [CHANGE DATA] must first be activated; the parameter value can then be changed using the [+/-] keys.

If a given parameter display shows three dots to the right, it means that the parameter value has more than three digits. In order to see the entire value, activate [CHANGE DATA].

The display shows that in parameter 128 *Motor thermal protection*, the selection made is *Thermistor trip* [2].

Quick menu

Using the [QUICK MENU] key, it is possible to access the 12 most important parameters of the adjustable frequency drive. After programming, the adjustable frequency drive is, in most cases, ready for operation. When the [QUICK MENU] key is activated in Display mode, the Quick menu starts. Scroll through the quick menu using the [+/-] keys and change the data values by first pressing [CHANGE DATA] and then changing the parameter value with the [+/-] keys.

The Quick menu parameters are:

- Par. 100 *Configuration*
- Par. 101 *Torque characteristic*
- Par. 102 *Motor power* $P_{M,N}$
- Par. 103 *Motor voltage* $U_{M,N}$
- Par. 104 *Motor frequency* $f_{M,N}$
- Par. 105 *Motor current* $I_{M,N}$
- Par. 106 *Rated motor speed* $n_{M,N}$
- Par. 107 *Automatic motor adaptation*
- Par. 202 *Output frequency high limit* f_{MAX}
- Par. 203 *Reference range*
- Par. 204 *Minimum reference* Ref_{MIN}
- Par. 205 *Maximum reference* Ref_{MAX}
- Par. 207 *Ramp-up time*
- Par. 208 *Ramp-down time*
- Par. 002 *Local/remote operation*
- Par. 003 *Local reference*

Parameter 102 - 106 can be read out from the motor's nameplate.

Automatic motor tuning

Automatic motor tuning (AMT) is performed as follows:

1. In parameter 107 *Automatic motor tuning*, select data value [2]. "107" will now flash, and "2" will not flash.
2. AMT is activated by pressing start. "107" will now flash and dashes will move from left to right in the data value field.
3. When "107" appears once more with the data value [0], AMT is complete. Press [STOP/RESET] to save the motor data.
4. "107" will then continue to flash with the data value [0]. You can now proceed.

**NOTE**

VLT 2880-2882 do not have AMT function.

■ Display readout
Fr

The variable frequency drive shows the present output frequency in Hertz [Hz].

Io

The variable frequency drive shows the present output current in Amps [A].

Uo

The variable frequency drive shows the present output voltage in Volt [V].

Ud

The variable frequency drive shows the intermediate circuit voltage in Volt [V].

Po

The variable frequency drive shows the calculated output in kilowatt [kW].

notrun

This message is shown if an attempt is made to change a parameter value while the motor is running. Stop the motor to change the parameter value.

LCP

This message is shown if an LCP 2 control unit is fitted and the [QUICK MENU] or [CHANGE DATA] key is activated. If an LCP 2 control unit is fitted you can only change parameters with that.

Ha

The variable frequency drive shows the present Hand mode reference frequency in Herz (Hz).

SC

The variable frequency drive shows scaled output frequency (the present output frequency x parameter 008).

■ Hand Auto

During normal operation the adjustable frequency drive is in auto mode, where the reference signal is given externally, analog or digital via the control terminals. However, in hand mode, it is possible to give the reference signal locally via the control panel.

On the control terminals, the following control signals will remain active when hand mode is activated:

- Hand Start (LCP2)
- Off Stop (LCP2)
- Auto Start (LCP2)
- Reset
- Coasting Stop Inverse
- Reset and Coasting Stop Inverse
- Quick Stop Inverse
- Stop Inverse
- Reversing
- DC Braking Inverse
- Set-up Select LSB
- Set-up Select MSB
- Thermistor
- Precise Stop Inverse
- Precise Stop/Start
- Jog
- Stop Command Via Serial Comm.

Switching between Auto Mode and Hand mode:

By activating the [Change Data] key in [Display Mode], the display will indicate the mode of the adjustable frequency drive.

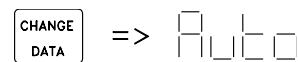

Scroll up/down in order to switch to hand mode:

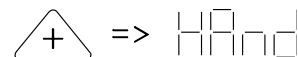

When the adjustable frequency drive is in hand mode, the readout will appear as follows:

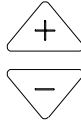

and the reference can be changed by using the following keys:

**NOTE**

Please note that parameter 020 may block the choice of mode.

■ Warnings/alarms

Warnings or alarms appear in the LED display as a numerical code [Err. xx]. A warning is displayed until the fault has been corrected, while an alarm will flash until the [STOP/RESET] key is pressed. The table in *Warnings/alarms messages* in this manual explains the various warnings and alarms, and whether a fault locks the adjustable frequency drive. After a Trip locked fault, cut off the AC line supply and correct the fault. Then reconnect the AC line supply and press the [STOP/RESET] key. The adjustable frequency drive is now reset and ready. See *Warnings/alarms messages* in this manual for more detail.

■ Special conditions

■ Derating for ambient temperature

The ambient temperature ($T_{AMB,MAX}$) is the maximum temperature allowed. The average ($T_{AMB,AVG}$) measured over 24 hours, must be at least 5 °C lower. If the frequency converter operates at temperatures above 45 °C, a derating of the rated output current is necessary.

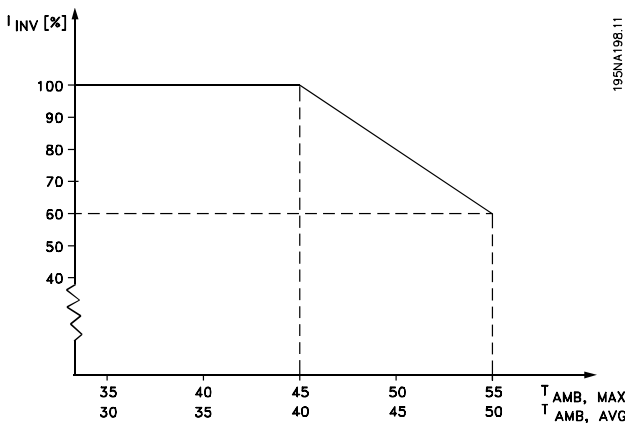

■ Temperature-related switching frequency

This function ensures the highest possible switching frequency without the adjustable frequency drive becoming thermally overloaded. The internal temperature determines the switching frequency based on the load, the ambient temperature, the supply voltage and the cable length. The function ensures that the drive automatically adjusts the switching frequency between the minimum and maximum switching frequency (parameter 411), see drawing below.

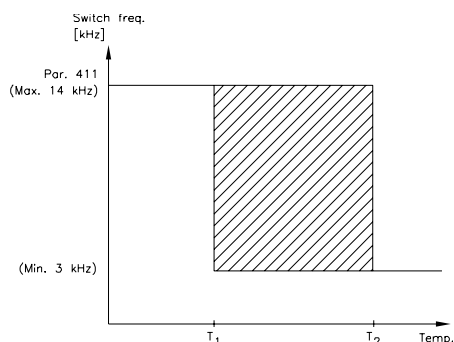

When using the LC filter the minimum switch frequency is 4.5 kHz.

■ Derating for long motor cables

The adjustable frequency drive has been designed for a 240 ft (75 m) unscreened/unarmored cable or a 80 ft (25 m) screened/armored cable and a motor cable with a rated cross-section. If a cable with a larger cross-section is required, it is recommended to reduce the output current by 5% for each step that the cable cross-section is increased. (Increased cable cross-section leads to increased capacitance to ground, and thus to an increased ground leakage current.)

■ VLT 2800 start-up

Pre-installation checks

- Compare drive model number to what was ordered.
- Ensure each of following are rated for same voltage:
 - Drive
 - Power line
 - Motor
- Record following motor data:
 - Voltage
 - Frequency
 - Full load current
 - Full load speed
 - Power - convert HP to kW (See conversion table in parameter 102, *Motor Power*, in this manual.)
- Ensure that rated drive current is equal to or greater than total full load current.
 - Drive can be *at most* one size smaller than motor.
 - For multiple motor operations, add full load current ratings of all motors.
 - If drive rating is less than motor(s), full motor output cannot be achieved.
- Check motor wiring:
 - Any disconnect between drive and motor should be interlocked to drive

VLT® 2800 Series

safety interlock circuit to avoid unwanted drive trips.

- No power factor correction capacitors can be connected between drive and motor.
- Two speed motors must be wired permanently for full speed.
- Y-start, Δ -run motors must be wired permanently for run.

Installation checks

1. Input fusing in power supply for all drives must be provided.
2. Environmental concerns - for standard NEMA 1 drive:
 - Clean air supply
 - Dry air (5% to 85% relative humidity, non-condensing)
 - 32°F (0°C) to 104°F (40°C) ambient temperature operating range, or as rated
 - 1000m (3,300 ft) maximum elevation with no derating
 - Keep any construction dirt out of drive.
3. Wiring
 - Wire drive in accordance with instructions and diagrams received with drive.
 - Separate conduits must be provided to drive for input power, output power, and control wiring.
 - Protect signal wires from noise.
 - Ground each drive individually.
 - Double check input and output power wiring for correct location.

Setting up drive for motor start

Ensure that all warnings provided in this manual have been adhered to. Apply power to the unit. Enter motor nameplate data into drive through Quick Menu.

1. Parameter 102, MOTOR POWER (in kW) (See conversion table in parameter 102, *Motor Power*, in this manual.)
2. Parameter 103, MOTOR VOLTAGE
3. Parameter 104, MOTOR FREQUENCY
4. Parameter 105, MOTOR CURRENT
5. Parameter 106, MOTOR SPEED
6. Parameter 107, select AUTOMATIC MOTOR TUNING

Operational tests - HAND

1. Check motor rotation from drive. If incorrect, disconnect input power from drive and reverse two leads between drive and motor.
2. Accelerate motor quickly to full speed and verify operation.
3. Decelerate motor quickly to stop and verify operation.
4. Operate motor over entire speed range while closely checking for resonance.

Operational tests - AUTO

1. Ensure that drive follows run/stop and safety interlock commands from system.
 2. Ensure drive follows speed reference, or feedback, from system.
-

■ Operation & Display

001	Language	
(language)		
Value:		
★	English (english)	[0]
	German (deutsch)	[1]
	French (français)	[2]
	Danish (dansk)	[3]
	Spanish (español)	[4]
	Italian (italiano)	[5]

Function:

This parameter is used to choose the language to be shown in the display whenever the LCP control unit is connected.

Description of choice:

There is a choice of the languages shown. The factory setting may vary.

002	Local/remote operation	
(OPERATION SITE)		
Value:		
★	Remote operation (REMOTE)	[0]
	Local operation (LOCAL)	[1]

Function:

There is a choice of two different modes of operation of the adjustable frequency drive; *Remote operation* [0] or *Local operation* [1]. See also parameter 013 *Local control* if *Local operation* [1] is selected.

Description of choice:

If *Remote operation* [0] is selected, the adjustable frequency drive is controlled via:

1. the control terminals or via serial communication.
2. the [START] key. This cannot, however, override stop commands transmitted via the digital inputs or via serial communication.
3. the [STOP/RESET] and [JOG] keys, on the condition that these are active.

If *Local operation* [1], is selected, the adjustable frequency drive is controlled via:

1. the [START] key. This cannot, however, override stop commands via the digital inputs (see parameter 013 *Local control*).
2. the [STOP/RESET] and [JOG] keys, on the condition that these are active.
3. the [FWD/REV] key, on the condition that it has been selected as active in parameter 016 *Local reversing*, and that parameter 013 *Local control* is set at *Local control and open loop* [1] or *Local control as parameter 100* [3]. Parameter 200 *Output frequency range* is set at *Both directions*.
4. parameter 003 *Local reference* where the reference can be set using the [+] and [-] keys.
5. an external control command that can be connected to the digital inputs (see parameter 013 *Local control*).



NOTE

The [JOG] and [FWD/REV] keys are located on the LCP control unit.

003	Local reference	
(LOCAL REFERENCE)		
Value:		
Par. 013 <i>Local control</i> must be set to [1] or [2]:		
0 - f _{MAX} (par. 205)		★ 50 Hz
Par. 013 <i>Local control</i> must be set to [3] or [4].		
Ref _{MIN} - Ref _{MAX} (par. 204-205)		★ 0,0

Function:

In this parameter, the local reference can be set manually. The unit of the local reference depends on the configuration selected in parameter 100 *Configuration*.

Description of choice:

In order to protect the local reference, parameter 002 *Local/remote operation* must be set to *Local operation* [1]. Local reference cannot be set via serial communication.

★ = factory setting, () = display text, [] = value for use in communication via serial communication port

004 Active Setup
(active Setup)

Value:	
Factory Setup (FACTORY SETUP)	[0]
★ setup 1 (setup 1)	[1]
setup 2 (setup 2)	[2]
Setup 3 (setup 3)	[3]
setup 4 (setup 4)	[4]
Multi Setup (MULTI SETUP)	[5]

Function:
The active parameter Setup is selected here. All parameters can be programmed in four individual parameter Setups. Shifts between Setups can be made in this parameter via a digital input or via serial communication.

Description of choice:
Factory Setup [0] contains the factory-set parameter values. *Setup 1-4* [1]-[4] are four individual Setups which can be selected as required. *Multi Setup* [5] is used where remote-controlled shifts between the four Setups via a digital input or via serial communication is required.

005 Programming Set-up
(EDIT SET-UP)

Value:	
Factory Set-up (FACTORY SET-UP)	[0]
Set-up 1 (set-up 1)	[1]
Set-up 2 (set-up 2)	[2]
Set-up 3 (set-up 3)	[3]
Set-up 4 (set-up 4)	[4]
★ Active Set-up (ACTIVE SET-UP)	[5]

Function:
You can select the desired set-up to program during operation (this applies both via the control panel and the serial communication port). For example, it is possible to program *Set-up 2* [2] while the active set-up is set to *Set-up 1* [1] in parameter 004 *Active Set-up*.

Description of choice:

Factory Set-up [0] contains the factory-set data and can be used as a source of data if the other set-ups are to be reset to a known status. *Set-up 1-4* [1]-[4] consists of individual set-ups that can be programmed freely during operation. If *Active Set-up* [5] is selected, the programming set-up will be equal to parameter 004 *Active Set-up*.



NOTE
If data is modified or copied to the active set-up, the modifications have an immediate effect on the unit's operation.

006 Setup copying
(SETUP COPY)

Value:	
★ No copying (NO COPY)	[0]
Copy to Setup 1 from # (COPY TO SETUP 1)	[1]
Copy to Setup 2 from # (COPY TO SETUP 2)	[2]
Copy to Setup 3 from # (COPY TO SETUP 3)	[3]
Copy to Setup 4 from # (COPY TO SETUP 4)	[4]
Copy to all Setups from # (copy to all)	[5]

Function:
You can copy from the selected active Setup in parameter 005 *Programming setup* to the selected Setup or Setups in this parameter.



NOTE
Copying is only possible in Stop (motor stopped in connection with a stop command).

Description of choice:

Copying begins when the required copying function has been selected and the [OK]/[CHANGE DATA] key has been pushed. The display indicates when copying is in progress.

★ = factory setting, () = display text, [] = value for use in communication via serial communication port

VLT® 2800 Series

007 LCP copy (LCP COPY)

Value:

- ★ No copying (NO COPY) [0]
- Upload all parameters (UPL. ALL PAR.) [1]
- Download all parameters (DWNL. ALL PAR.) [2]
- Download size-independent parameters (DWNL.OUTPIND.PAR.) [3]

Function:

Parameter 007 *LCP copy* is used if you want to use the LCP 2 control panel's integral copy function. The function is used if you want to copy all parameter setups from one adjustable frequency drive to another by moving the LCP 2 control panel.

Description of choice:

Select *Upload all parameters* [1] if you want all parameter values to be transferred to the control panel. Select *Download all parameters* [2] if all parameter values transferred are to be copied to the adjustable frequency drive to which the control panel is attached. Select *Download size-independent par.* [3] if you only want to download the size-independent parameters. This is used when downloading to a adjustable frequency drive with a different rated power size than that from which the parameter setup originates.



NOTE

Upload/download can only be performed in stop mode. Download can only be performed to a adjustable frequency drive with the same software version number, see parameter 626 *Database identification no.*

008 Display scaling of output frequency (FREQUENCY SCALE)

Value:

0.01 - 100.00 ★ 1.00

Function:

In this parameter, the factor is selected by which the output frequency is to be multiplied. The value is shown in the display, provided parameters 009-012

Display readout have been set to *Output frequency x scaling* [5].

Description of choice:

Set the required scaling factor.

009 Large display readout (DISPLAY LINE 2)

Value:

- No readout (none) [0]
- Resulting reference [%] (reference [%]) [1]
- Resulting reference [unit] (reference [unit]) [2]
- Feedback [unit] (feedback [unit]) [3]
- ★ Frequency [Hz] (Frequency [Hz]) [4]
- Output frequency x scaling (frequency x scale) [5]
- Motor current [A] (Motor current [A]) [6]
- Torque [%] (Torque [%]) [7]
- Power [kW] (Power [kW]) [8]
- Power [HP] (Power [HP][US]) [9]
- Motor voltage [V] (Motor voltage [V]) [11]
- DC link voltage [V] (DC link voltage [V]) [12]
- Thermal load motor [%] (Motor thermal [%]) [13]
- Thermal load [%] (FC. thermal[%]) [14]
- Running hours [Hours] (RUNNING HOURS) [15]
- Digital input [Bin] (Digital input[bin]) [16]
- Analog input 53 [V] (analog input 53 [V]) [17]
- Analog input 60 [mA] (analog input 60 [mA]) [19]
- Pulse reference [Hz] (Pulse ref. [Hz]) [20]
- External reference [%] (external ref. [%]) [21]
- Status word [Hex] (Status word [hex]) [22]

★ = factory setting, () = display text, [] = value for use in communication via serial communication port

Heatsink temperature [°C] (Heatsink temp [°C])	[25]
Alarm word [Hex] (Alarm word [hex])	[26]
Control word [Hex] (Control word [Hex])	[27]
Warning word [Hex] (warning word [Hex])	[28]
Extended status word [Hex] (Ext. status [hex])	[29]
Communication option card warning (COMM OPT WARN [HEX])	[30]
Pulse count (PULSE COUNTER)	[31]

Function:

In this parameter you can select the data value that you wish to display in the LCP 2 control unit display line 2 when the adjustable frequency drive is switched on. The display will also be included in the scrollbar in display mode. In parameters 010-012 *Display readout* you can select a further three data values, which are displayed in display line 1.

Description of choice:

No readout can only be selected in parameters 010-012 *Small display readout*.

Resulting reference [%] gives, as a percentage, the resulting reference in the range from Minimum reference, Ref_{MIN} to Maximum reference, Ref_{MAX}.

Reference [unit] gives the resulting reference with unit Hz in *Open loop*. In *Closed loop* the reference unit is selected in parameter 416 *Process units*.

Feedback [unit] gives the resulting signal value using the unit/scaling selected in parameter 414 *Minimum feedback, FB_{LOW}*, 415 *Maximum feedback, FB_{HIGH}* and 416 *Process units*.

Frequency [Hz] gives the output frequency of the adjustable frequency drive.

Output frequency x scaling [-] equals the present output frequency f_M multiplied by the factor set in parameter 008 *Display scaling of output frequency*.

Motor current [A] gives the phase current of the motor measured as an effective value.

Torque [%] denotes the motor's present load in relation to the motor's rated torque.

Power [kW] gives the present power that the motor is absorbing in kW.

Power [HP] gives the present power that the motor is absorbing in HP.

Motor voltage[V] gives the voltage supplied to the motor.

DC link voltage [V] gives the intermediate circuit voltage of the adjustable frequency drive.

Thermal load motor [%] gives the calculated/estimated load on the motor. 100 % is the cut-out limit.

Thermal load [%] gives the calculated/estimated thermal load on the adjustable frequency drive. 100 % is the cut-out limit.

Running hours [Hours] gives the number of hours that the motor has run since the last reset in parameter 619 *Reset of running hours counter*.

Digital input [Binary code] gives the signal status from the 5 digital inputs (18, 19, 27, 29 and 33). Terminal 18 corresponds to the bit on the extreme left. '0' = no signal, '1' = signal connected.

Analog input 53 [V] gives the voltage value of terminal 53.

Analog input 60 [mA] gives the present value of terminal 60.

Pulse reference [Hz] gives the reference in Hz connected to terminal 33.

External reference [%] gives the sum of external references as a percentage (sum of analogue/pulse/serial communication) in the range from Minimum reference, Ref_{MIN} to Maximum reference, Ref_{MAX}.

Status word [Hex] gives one or several status conditions in a Hex code. See *Serial communication* in the *VLT 2800 Design Guide* for further information.

Heatsink temp.[°C] gives the present heatsink temperature of the adjustable frequency drive. The cut-out limit is 90-100°C, while cutting back in occurs at 70 ± 5°C.

Alarm word [Hex] gives one or several alarms in hex code. See *Serial communication* in the *VLT 2800 Design Guide* for further information.

Control word [Hex] gives the control word for the adjustable frequency drive. See *Serial communication* in the *VLT 2800 Design Guide* for further information.

★ = factory setting, () = display text, [] = value for use in communication via serial communication port

Warning word [Hex] gives one or several warnings in hex code. See *Serial communication* in the *VLT 2800 Design Guide* for further information.

Extended status word [Hex] gives one or several status modes in Hex code. See *Serial communication* in the *VLT 2800 Design Guide* for further information.

Communication option card warning [Hex] gives a warning word if there is a fault in the communication bus. Only active if communication options are installed.

If there are no communication options 0 Hex is displayed.

Pulse count gives the number of pulses that the unit has registered.

010 Small display line 1.1 (DISPLAY LINE 1.1)

Value:

See par. 009 *Large display* ★ Analog input 53 readout [V] [17]

Function:

In this parameter, the first of three data values can be selected that is to be displayed in the LCP control unit display, line 1, position 1. This is a useful function, e.g. when setting the PID regulator, as it gives a view of process reactions to reference changes. The display readout is activated by pushing the [DISPLAY STATUS] key.

Description of choice:

See parameter 009 *Large display readout*.

011 Small display readout 1.2 (DISPLAY LINE 1.2)

Value:

See parameter 009 *Large display* ★ Motor current [A][6]

Function:

See the functional description given under parameter 010 *Small display readout*.

Description of choice:

See parameter 009 *Large display readout*.

012 Small display readout 1.3 (DISPLAY LINE 1.3)

Value:

See parameter 009 *Large display* ★ Feedback readout [unit] [3]

Function:

See the functional description given under parameter 010 *Small display readout*.

Description of choice:

See parameter 009 *Large display readout*.

013 Local control (LOC CTRL/CONFIG.)

Value:

- Local not active (DISABLE) [0]
- Local control and open loop without slip compensation (LOC CTRL/OPEN LOOP) [1]
- Remote-operated control and open loop without slip compensation (LOC+DIG CTRL) [2]
- Local control as parameter 100 (LOC CTRL/AS P100) [3]
- ★ Remote-operated control as parameter 100 (LOC+DIG CTRL/AS P100) [4]

Function:

This is where the required function is selected if, in parameter 002 *Local/remote operation*, *Local operation* [1] has been chosen.

Description of choice:

If *Local not active* [0] is selected, it is not possible to set a reference via parameter 003 *Local reference*. In order to enable a shift to *Local not active* [0], parameter 002 *Local/remote operation* must be set to *Remote operation* [0].

Local control and open loop [1] is used if the motor speed is to be set via parameter 003 *Local reference*. When this choice is made, parameter 100 *Configuration* automatically shifts to *Speed regulation, open loop* [0].

Remote-operated control and open loop [2] functions in the same way as *Local control and open loop* [1];

★ = factory setting, () = display text, [] = value for use in communication via serial communication port

however, the adjustable frequency drive can also be controlled via the digital inputs.

For selections [1-2] control is shifted to open loop, no slip compensation.

Local control as parameter 100 [3] is used when the motor speed is to be set via parameter 003 *Local reference*, but without parameter 100 *Configuration* automatically shifting to *Speed regulation, open loop* [0].

Remote-operated control as parameter 100 [4] works the same way as *Local control as parameter 100 [3]*; however, the adjustable frequency drive can also be controlled via the digital inputs.

Shifting from *Remote operation* to *Local operation* in parameter 002 *Local/remote operation*, while this parameter has been set to *Remote-operated control and open loop* [1]: The present motor frequency and direction of rotation will be maintained. If the present direction of rotation does not respond to the reversing signal (negative reference), the reference will be set to 0.

Shifting from *Local operation* to *Remote operation* in parameter 002 *Local/remote control*, while this parameter has been set to *Remote-operated control and open loop* [1]: The configuration selected in parameter 100 *Configuration* will be active. The shift will be smooth.

Shifting from *Remote control* to *Local control* in parameter 002 *Local/remote operation*, while this parameter has been set to *Remote-operated control as parameter 100 [4]*: the present reference will be maintained. If the reference signal is negative, the local reference will be set to 0.

Shifting from *Local operation* to *Remote operation* in parameter 002 *Local/remote operation*, while this parameter has been set to *Remote operation*: The local reference will be replaced by the remote-operated reference signal.

014	Local stop
(LOCAL STOP)	
Value:	
	Not active (DISABLE) [0]
★	Active (ENABLE) [1]

Function:

In this parameter, the local [STOP]-key can be engaged or disengaged on the control panel and on the LCP control panel.

Description of choice:

If *Not active* [0] is selected in this parameter, the [STOP]-key will be inactive.



NOTE

If *Not active* [0] is selected, the motor cannot be stopped by means of the [STOP]-key.

015	Local jog
(LOCAL JOGGING)	
Value:	
★	Not active (DISABLE) [0]
	Active (ENABLE) [1]

Function:

In this parameter, the jog function on the LCP control panel can be engaged/disengaged.

Description of choice:

If *Not active* [0] is selected in this parameter, the [JOG]-key will be inactive.

016	Local reverse
(LOCAL REVERSE)	
Value:	
★	Not active (DISABLE) [0]
	Active (ENABLE) [1]

Function:

In this parameter you can select/deselect the reverse function on the LCP control panel. The key can only be used if parameter 002 *Local/remote operation* is set to *Local operation* [1] and parameter 013 *Local control to Local control, open loop* [1] or *Local control as parameter 100 [3]*.

★ = factory setting, () = display text, [] = value for use in communication via serial communication port

Description of choice:

If *Disable* [0] is selected in this parameter, the [FWD/REV] key will be disabled. See also parameter 200 *Output frequency range*.

017 Local reset of trip (LOCAL RESET)

Value:

- Not active (DISABLE) [0]
- ★ Active (ENABLE) [1]

Function:

In this parameter, the reset function on the control panel can be engaged/disengaged.

Description of choice:

If *Not active* [0] is selected in this parameter, the reset function will be inactive.



NOTE

Select *Not active* [0], only if an external reset signal has been connected via the digital inputs.

018 Lock for data changes (DATA CHANGE LOCK)

Value:

- ★ Not locked (NOT LOCKED) [0]
- Locked (LOCKED) [1]

Function:

In this parameter, it is possible to 'lock' the controls to disable data changes via the control keys.

Description of choice:

If *Locked* [1] is selected, data changes in the parameters cannot be made; however, it will still be possible to make data changes via serial communication. Parameter 009-012 *Display readout* can be changed via the control panel.

019 Operating mode at power-up, local operation

(POWER UP ACTION)

Value:

- Auto restart, use saved reference (AUTO RESTART) [0]
- ★ Forced stop, use saved reference (LOCAL=STOP) [1]
- Forced stop, set ref. to 0 (LOCAL=STOP, REF=0) [2]

Function:

Setting of the required operating mode when the mains voltage is engaged. This function can only be active if *Local operation* [1] has been selected in parameter 002 *Local/remote operation*.

Description of choice:

Auto restart, use saved ref. [0] is selected if the adjustable frequency drive is to start using the local reference (set in parameter 003 *Local reference*) and the start/stop state given via the control keys immediately prior to the mains voltage being cut out.

Forced stop, use saved ref. [1] is selected if the adjustable frequency drive is to remain stopped when the mains voltage is engaged, until the [START]-key is activated. After a start command the motor speed is ramped up to the saved reference in parameter 003 *Local reference*.

Forced stop, set ref. to 0 [2] is selected if the adjustable frequency drive is to remain stopped when the mains voltage is cut back in. Parameter 003 *Local reference* is to be zeroed.



NOTE

In remote operation (parameter 002 *Local/remote operation*) the start/stop state at the time of mains connection will depend on the external control signals. If *Pulse start* [8] is selected in parameter 302 *Digital input*, the motor will remain stopped after mains connection.

★ = factory setting, () = display text, [] = value for use in communication via serial communication port

020 Hand operation
(HAND OPERATION)

Value:

- ★ Not active (DISABLE) [0]
- Active (ENABLE) [1]

Function:

In this parameter you can select whether it should be possible or not to switch between Auto- and Hand mode. In Auto mode the adjustable frequency drive is controlled by external signals whereas the adjustable frequency drive in Hand mode is controlled via a local reference directly from the control unit.

Description of choice:

If *Not active* [0] is selected in this parameter, the Hand mode function will be inactive. If *Active* [1] is selected you can switch between Auto- and Hand mode. For further information, see the *Control Unit* section.

024 Userdefined Quick Menu
(user quickmenu)

Value:

- ★ Not active (Disable) [0]
- Active (Enable) [1]

Function:

In this parameter you can select the standard setup of the Quick menu key on the control panel and the LCP 2 control panel.

Using this function, in parameter *025 Quick Menu setup* the user can select up to 20 parameters for the Quick Menu key.

Description of choice:

If *not active* [0] is selected, the standard setup of the Quick Menu key is active.

If *Active* [1] is selected, the user-defined Quick Menu is active.

025 Quick Menu setup
(Quick Menu setup)

Value:

[Index 1 - 20] Value: 0 - 999 ★ 000

Function:

In this parameter you define which parameters are required in the Quick Menu when parameter *024 User-defined Quick Menu* is set to *Active* [1].

Up to 20 parameters can be selected for the user-defined Quick Menu.



NOTE

Please note that this parameter can only be set using an LCP 2 control panel. See *Order form*.

Description of choice:

The Quick Menu is set up as follows:

1. Select parameter *025 Quick Menu setup* and press [CHANGE DATA].
2. Index 1 indicates the first parameter in Quick Menu. You can scroll between the index numbers using the [+ / -] keys. Select Index 1.
3. Using [< >] you can scroll between the three figures. Press the [<] key once and the last number in the parameter number can be selected using the [+ / -] keys. Set Index 1 to 100 for parameter *100 Configuration*.
4. Press [OK] when Index 1 has been set to 100.
5. Repeat steps 2 - 4 until all parameters required have been set to the Quick Menu key.
6. Press [OK] to complete the Quick Menu setup.

If parameter *100 Configuration* is selected at Index 1, Quick Menu will start with this parameter every time Quick Menu is activated.

Please note that parameter *024 User-defined Quick Menu* and parameter *025 Quick Menu setup* are reset to the factory setting during initialisation.

★ = factory setting, () = display text, [] = value for use in communication via serial communication port

■ Load and Motor

100 Configuration	
(Configuration)	
Value:	
★ Speed control, open-loop (SPEED OPEN-LOOP)	[0]
Speed control, closed-loop (SPEED CLOSED-LOOP)	[1]
Process control, closed-loop (PROCESS CLOSED-LOOP)	[3]

Function:
This parameter is used to select the configuration to which the adjustable frequency drive is to be adapted. This makes adaptation to a given application simple, since the parameters not used in a given configuration are hidden (not active).

Description of choice:
If *Speed control, open-loop* [0] is selected, normal speed control is obtained (without feedback signal) with automatic load and slip compensation to ensure a constant speed at varying loads. Compensations are active, but may be disabled in parameter 134 *Load compensation* and parameter 136 *Slip compensation* as required.

If *Speed control, closed-loop* [1] is selected, better speed accuracy is obtained. A feedback signal must be added, and the PID regulator must be set in parameter group 400 *Special functions*.

If *Process control, closed-loop* [3] is selected, the internal process regulator is activated to enable precise control of a process in relation to a given process signal. The process signal can be set to the relevant process unit or as a percentage. A feedback signal must be added from the process, and the process regulator must be set in parameter group 400 *Special functions*. Process closed-loop is not active if a DeviceNet card is mounted and Instance 20/70 or 21/71 is chosen in parameter 904 *Instance types*.

101 Torque characteristic	
(TORQUE CHARACT)	
Value:	
★ Constant torque (Constant torque)	[1]
Variable torque low (torque: low)	[2]
Variable torque medium (torque: med)	[3]
Variable torque high (torque: high)	[4]
Variable torque low with CT start (VT LOW CT START)	[5]
Variable torque medium with CT start (VT MED CT START)	[6]
Variable torque high with CT start (VT HIGH CT START)	[7]
Special motor mode (Special motor mode)	[8]

CT = Constant torque

Function:
This parameter enables a choice of principle for adaptation of the U/f ratio of the variable frequency drive to the torque characteristic of the load. See par. 135 *U/f ratio*.

Description of choice:
If *Constant torque* [1] is selected, a load-dependent U/f characteristic is obtained, in which output voltage and output frequency are increased at increasing loads in order to maintain constant magnetization of the motor.
Select *Variable torque low* [2], *Variable torque medium* [3] or *Variable torque high* [4], if the load is square (centrifugal pumps, fans).
Variable torque - low with CT start [5], *- medium with CT start* [6] or *high with CT start* [7], are selected if you need a greater breakaway torque than can be achieved with the three first characteristics.



NOTE

Load and slip compensation are not active if variable torque or special motor mode have been selected.

★ = factory setting, () = display text, [] = value for use in communication via serial communication port

VLT® 2800 Series

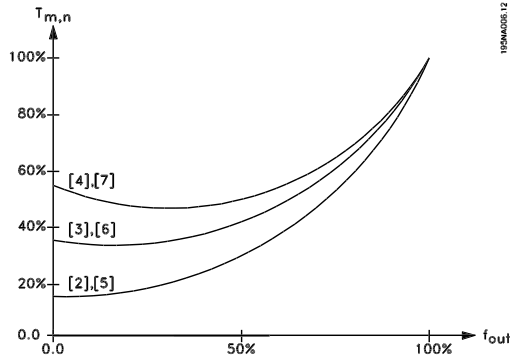

Select *Special motor mode* [8], if a special U/f setting is needed that is to be adapted to the present motor. The break points are set in parameters 423-428 *Voltage/frequency*.



NOTE

If a value set in the name-plate parameters 102-106 is changed, parameters 108 *Stator resistance* and 109 *Stator reactance* change automatically. Enter motor name plate data in sequence from parameter 102 to 106. The relationship between values are interdependent.

102 Motor power $P_{M,N}$ (motor power)

Value:

0.25 - 22 kW ☆ Depends on unit

Function:

Here you must set a power value [kW] $P_{M,N}$, corresponding to the motor's rated power.

Description of choice:

Set a value that matches the nameplate data on the motor. Settings between one size below and one size over the factory setting are possible.

North American HP to kW Conversion Chart	
HP	kW
1/2	0.37
3/4	0.55
1	0.75
1 1/2	1.1
2	1.5
3	2.2
4	3.0
5	4
7 1/2	5.5
10	7.5

103 Motor voltage $U_{M,N}$ (MOTOR VOLTAGE)

Value:

For 200 V units: 50 - 999 V ☆ 230 V
For 400 V units: 50 - 999 V ☆ 400 V

Function:

This is where to set the rated motor voltage.

Description of choice:

Select a value that corresponds to the nameplate data on the motor, regardless of the adjustable frequency drive's AC line voltage.

104 Motor frequency $f_{M,N}$ (MOTOR FREQUENCY)

Value:

24-1000 Hz ☆ 50 Hz

Function:

This is where to select the rated motor frequency $f_{M,N}$.

Description of choice:

Select a value that corresponds to the nameplate data on the motor.

105 Motor current $I_{M,N}$ (MOTOR CURRENT)

Value:

0,01 - I_{MAX} ☆ Depends on choice of motor

☆ = factory setting, () = display text, [] = value for use in communication via serial communication port

Function:

The nominal, rated current of the motor $I_{M,N}$ forms part of the variable frequency drive calculation of features such as torque and motor thermal protection.

Description of choice:

Set a value that corresponds to the nameplate data on the motor. Set the motor current $I_{M,N}$ taking into account whether the motor is star-connected Y or delta-connected Δ .

106 Rated motor speed

(MOTOR NOM. SPEED)

Value:

100 - $f_{M,N} \times 60$
(max. 60000) ☆ Depends on parameter 104 *Motor frequency, $f_{M,N}$*

Function:

This is where to set the value that corresponds to the rated motor speed $n_{M,N}$ that can be seen from the nameplate data.

Description of choice:

Select a value that corresponds to the nameplate data on the motor.



NOTE

The max. value equals $f_{M,N} \times 60$. $f_{M,N}$ to be set in parameter 104 *Motor frequency, $f_{M,N}$* .

107 Automatic motor tuning, AMT

(auto motor tun.)

Value:

☆ Optimisation off (AMT off) [0]
Optimisation on (AMT start) [2]

Function:



NOTE

AMT is not possible on VLT 2880-82.

- For AMT to define the motor parameters accurately, the correct nameplate data for the motor connected to the adjustable frequency drive must be keyed into parameters 102 to 106.
- Alarms will appear in the display if faults arise during tuning of the motor. See *Warnings/alarms messages* in this manual.
- As a rule, the AMT function can measure the R_s values for motors that are 1-2 sizes larger or smaller than the adjustable frequency drive's nominal size.
- If you wish to interrupt automatic motor tuning, press the [STOP/RESET] key.



NOTE

AMT may not be performed on motors connected in parallel, nor may setup changes be made while AMT is running.

See *Automatic motor tuning* in this manual for the AMT procedure.

Description of choice:

Select *Optimization on* [2] as part of the AMT procedure if you want the adjustable frequency drive to perform automatic motor tuning.

108 Stator resistance R_s

(STATOR RESISTAN)

Value:

0.000 - X.XXX Ω ☆ Depends on choice of motor

Function:

After setting of parameters 102-106 *Nameplate data*, a number of adjustments of various parameters is carried out automatically, including stator resistance R_s . A manually entered R_s must apply to a cold motor. The shaft performance can be improved by fine-tuning R_s and X_s , see procedure below.



NOTE

Parameters 108 *Stator resistance R_s* and 109 *Stator reactance X_s* are normally not to be changed if nameplate data has been set.

☆ = factory setting, () = display text, [] = value for use in communication via serial communication port

Description of choice:

R_S can be set as follows:

1. Use the factory settings of R_S which the adjustable frequency drive itself chooses on the basis of the motor nameplate data.
2. The value is stated by the motor supplier.
3. The value is obtained through manual measurements: R_S can be calculated by measuring the resistance R_{PHASE-PHASE} between two phase terminals. Where R_{PHASE-PHASE} is lower than 1-2 Ohms (typical for motors > 7.5 HP, 400 V), a special Ohm-meter should be used (Thomson-bridge or similar). **R_S = 0.5 x R_{PHASE-PHASE}** .
4. R_S is set automatically when AMT has been completed. See parameter 107 *Auto motor tuning*.

109 Stator reactance X_S

(STATOR REACTANCE)

Value:

0.00 - X,XX Ω ☆ Depends on choice of motor

Function:

After parameters 102-106 *Nameplate data* are set, a number of parameters are adjusted automatically, including stator reactance X_S. The shaft performance can be improved by fine-tuning R_S and X_S; see procedure below.

Description of choice:

X_S can be set as follows:

1. The value is stated by the motor supplier.
2. The value is obtained through manual measurements; X_S is obtained by connecting a motor to line power and measuring the phase-phase voltage U_M and the idle current φ.

$$X_S = \frac{U_M}{\sqrt{3} \times I_\phi} - \frac{X_L}{2}$$

X_L: See parameter 142.

3. Use the factory settings of X_S, which the adjustable frequency drive itself chooses on the basis of the motor nameplate data.

117 Resonance damping

(resonance damping)

Value:

OFF 100 [OFF 100]

☆ Off [OFF]

Function:

It is possible to optimize the resonance damping in CT mode. The grade of the influence is adjusted in this parameter.

The value may be set between 0% (OFF) and 100%. 100% corresponds to 50% reduction of U/F ratio. Default value is OFF.

Internal settings (fixed):

The resonance filter is active from 10% of nominal speed and above.

In this case 5Hz and above.

Speed to go from 0 to nominal flux level: 500ms

Speed to go from nominal to 0 flux level: 500 ms

Description of functionality:

The filter monitors the active motor current and changes the motor voltage according to the figure below. The filter reacts on levels referring to the nominal motor current.

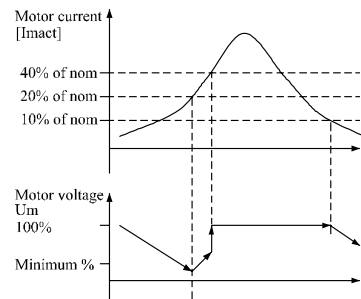

175NA105.10

If the active motor current is below 10%, the motor voltage will be decreased by the speed mentioned above until the voltage reaches the setting for Par. 117. If the active motor current comes over 20% the voltage will be increased by the above-mentioned speed. If the active motor current reaches 40% the motor voltage will be increased immediately to normal motor voltage.

The reduction in motor voltage depends on the parameter 117 setting.

☆ = factory setting, () = display text, [] = value for use in communication via serial communication port

Description of choice:

Set the grade of Motor current [Imact] influence on the U/F ratio between 0% (OFF) and 100%. 100% corresponds to 50% reduction of U/F ratio. Default value is OFF.

119 High start torque
(High start torq.)
Value:

0.0 - 0.5 sec. ☆ 0.0 sec.

Function:

To ensure a high start torque approx. $1.8 \times I_{INV}$. can be permitted for max. 0.5 sec. The current is, however, limited by the variable frequency drive's (inverter's) safety limit. 0 sec. corresponds to no high start torque.

Description of choice:

Set the necessary time for which a high start torque is required.

120 Start delay
(START DELAY)
Value:

0.0 - 10.0 sec. ☆ 0.0 sec.

Function:

This parameter enables a delay of the start-up time after the conditions for start have been fulfilled. When the time has passed, the output frequency will start by ramping up to the reference.

Description of choice:

Set the necessary time before commencing to accelerate.

121 Start function
(START FUNCTION)
Value:

- DC hold during start delay time (DC HOLD/DELAY TIME) [0]
- DC brake during start delay time (DC BRAKE/DELAY TIME) [1]
- ☆ Coasting during start delay time [2]

(COAST/DELAY TIME)

Start frequency/voltage clockwise (CLOCKWISE OPERATION) [3]

Start frequency/voltage in reference direction (VERTICAL OPERATION) [4]

Function:

This is where to choose the required mode during the start delay time (parameter 120 *Start delay time*).

Description of choice:

Select *DC hold during start delay time* [0] to energize the motor with a DC hold voltage during the start delay time. Set voltage in parameter 137 *DC hold voltage*.

Choose *DC brake during start delay time* [1] to energize the motor with a DC brake voltage during the start delay time. Set voltage in parameter 132 *DC brake voltage*.

Choose *Coasting during start delay time* [2] and the motor will not be controlled by the adjustable frequency drive during the start delay time (inverter turned off).

Choose *Start frequency/voltage clockwise* [3] to obtain the function described in parameter 130 *Start frequency* and 131 *Voltage at start* during start delay time. Regardless of the value assumed by the reference signal, the output frequency equals the setting in parameter 130 *Start frequency* and the output voltage will correspond to the setting in parameter 131 *Voltage at start*.

This functionality is typically used in hoist applications. It is used in particular in applications in which a cone anchor motor is applied, where the direction of rotation is to start clockwise followed by the reference direction.

Select *Start frequency/voltage in reference direction* [4] to obtain the function described in parameter 130 *Start frequency* and 131 *Voltage at start* during the start delay time.

The direction of rotation of the motor will always follow in the reference direction. If the reference signal equals zero, the output frequency will equal 0 Hz, while the output voltage will correspond to the setting in parameter 131 *Voltage at start*. If the reference signal is different from zero, the output frequency will equal parameter 130 *Start frequency* and the output voltage will equal parameter 131 *Voltage at start*. This functionality is used typically for hoist applications with counter-

☆ = factory setting, () = display text, [] = value for use in communication via serial communication port

weight. It is used in particular for applications in which a cone anchor motor is applied. The cone anchor motor can break away using parameter 130 *Start frequency* and parameter 131 *Voltage at start*.

**122 Function at stop
(FUNCTION AT STOP)**

Value:

- ★ Coasting (COAST) [0]
- DC hold (DC HOLD) [1]

Function:

This is where to choose the function of the variable frequency drive after the output frequency has become lower than the value in parameter 123 *The min. frequency for activation of function at stop* or after a stop command and when the output frequency has been ramped down to 0 Hz.

Description of choice:

Select *Coasting* [0] if the variable frequency drive is to 'let go' of the motor (inverter turned off).

Select DC hold [1] if parameter 137 *DC hold voltage* is to be activated.

**123 Min. frequency for activation of function at stop
(MIN.F.FUNC.STOP)**

Value:

- 0,1 - 10 Hz ★ 0,1 Hz

Function:

In this parameter, the output frequency is set at which the function selected in parameter 122 *Function at stop* is to be activated.

Description of choice:

Set the required output frequency.



NOTE

If parameter 123 is set higher than parameter 130, then the start delay function (parameter 120 and 121) will be skipped.



NOTE

If parameter 123 is set too high, and DC hold has been chosen in parameter 122, the output frequency will jump to the value in parameter 123 without ramping up. This may cause an overcurrent warning / alarm.

**126 DC brake time
(DC BRAKING TIME)**

Value:

- 0 - 60 sec. ★ 10 sec

Function:

In this parameter, the DC brake time is set at which parameter 132 *DC brake voltage* is to be active.

Description of choice:

Set the required time.

**127 DC brake cut-in frequency
(DC BRAKE CUT-IN)**

Value:

- 0.0 (OFF) - par. 202 ★ OFF
- Output frequency high limit, f_{MAX}*

Function:

In this parameter, the DC brake cut-in frequency is set at which the DC brake is to be activated in connection with a stop command.

Description of choice:

Set the required frequency.

**128 Thermal motor protection
(MOT.THERM PROTEC)**

Value:

- ★ No protection (NO PROTECTION) [0]
- Thermistor warning (THERMISTOR WARN) [1]
- Thermistor trip (THERMISTOR TRIP) [2]
- ETR warning 1 (ETR WARNING 1) [3]
- ETR trip 1 (ETR TRIP 1) [4]

★ = factory setting, () = display text, [] = value for use in communication via serial communication port

ETR warning 2 (ETR WARNING 2)	[5]
ETR trip 2 (ETR TRIP 2)	[6]
ETR warning 3 (ETR WARNING 3)	[7]
ETR trip 3 (ETR TRIP 3)	[8]
ETR warning 4 (ETR WARNING 4)	[9]
ETR trip 4 (ETR TRIP 4)	[10]

Function:

The adjustable frequency drive can monitor the motor temperature in two different ways:

- Via a PTC thermistor that is mounted on the motor. The thermistor is connected between terminal 50 (+10V) and one of the digital input terminals 18, 19, 27 or 29. See parameter 300 *Digital inputs*.
- Thermal load calculation (ETR - Electronic Thermal Relay), based on present load and time. This is compared with the rated motor current $I_{M,N}$ and rated motor frequency $f_{M,N}$. The calculations take into account the need for lower loading at low speeds due to the motor's internal ventilation being reduced.

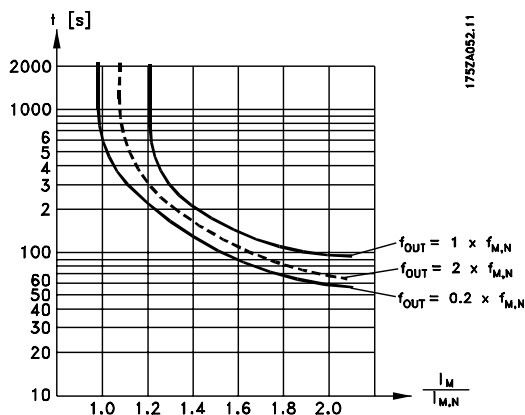

ETR functions 1-4 do not begin to calculate the load until you switch to the Setup in which they have been selected. This means that you can use the ETR function even when changing between two or more motors.

Description of choice:

Select *No protection* [0] if you do not want a warning or trip when a motor is overloaded.

Select *Thermistor warning* [1] if you want a warning when the connected thermistor becomes too hot.

Select *Thermistor trip* [2] if you want a trip when the connected thermistor becomes too hot.

Select *ETR warning 1-4* if you want a warning when the motor is overloaded according to the calculations. You can also program the adjustable frequency drive to give a warning signal via one of the digital outputs. Select *ETR Trip 1-4* if you want a trip when the motor is overloaded according to the calculations.



NOTE

This function cannot protect the individual motors in the case of motors linked in parallel.

130 Start frequency

(Start frequency)

Value:

0.0 - 10.0 Hz ★ 0.0 Hz

Function:

The start frequency is active for the time set in parameter 120 *Start delay*, after a start command. The output frequency will 'jump' to the next preset frequency. Certain motors, such as conical anchor motors, need an extra voltage/start frequency (boost) at start to disengage the mechanical brake. To achieve this parameters 130 *Start frequency* and 131 *Initial voltage* are used.

Description of choice:

Set the required start frequency. It is a precondition that parameter 121 *Start function*, is set to *Start frequency/voltage clockwise* [3] or *Start frequency voltage in reference direction* [4] and that in parameter 120 *Start delay* a time is set and a reference signal is present.



NOTE

If parameter 123 is set higher than parameter 130, the start delay function (parameter 120 and 121) will be skipped.

131 Initial voltage

(INITIAL VOLTAGE)

Value:

0.0 - 200.0 V ★ 0.0 V

★ = factory setting, () = display text, [] = value for use in communication via serial communication port

Function:

Initial voltage is active for the time set in parameter 120 *Start delay*, after a start command. This parameter can be used for example for lifting/dropping applications (conical anchor motors).

Description of choice:

Set the required voltage necessary to cut out the mechanical brake. It is assumed that parameter 121 *Start function*, is set to *Start frequency/voltage clockwise* [3] or *Start frequency/voltage in reference direction* [4] and that in parameter 120 *Start delay* a time is set, and that a reference signal is present.

132 DC brake voltage

(DC BRAKE VOLTAGE)

Value:

0 - 100% of max. DC brake voltage ☆ 0%

Function:

In this parameter, the DC brake voltage is set which is to be activated at stop when the DC brake frequency set in parameter 127 *DC brake cut-in frequency* is reached, or if *DC braking inverse* is active via a digital input or via serial communication. Subsequently, the DC brake voltage will be active for the time set in parameter 126 *DC brake time*.

Description of choice:

To be set as a percentage value of the max. DC brake voltage, which depends on the motor.

133 Start voltage

(START VOLTAGE)

Value:

0.00 - 100.00 V ☆ Depends on unit

Function:

A higher start torque can be obtained by increasing the start voltage. Small motors (< 1.0 HP) normally require a high start voltage.

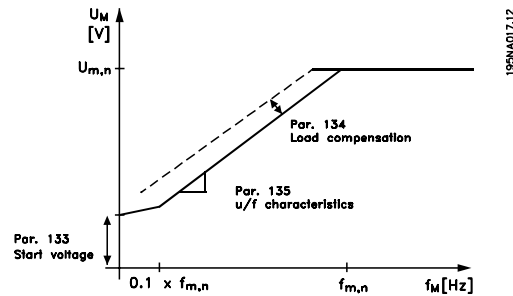

Description of choice:

The factory setting will be suitable for most applications, the value may need to be increased gradually for high torque applications.



Warning: If the use of start voltage is exaggerated, this may lead to over-energizing and overheating of the motor and the variable frequency drive may cut out.

134 Load compensation

(LOAD COMPENSATIO)

Value:

0.0 - 300.0% ☆ 100.0%

Function:

In this parameter, the load characteristic is set. By increasing the load compensation, the motor is given an extra voltage and frequency supplement at increasing loads. This is used e.g. in motors/applications in which there is a big difference between the full-load current and idle-load current of the motor.



NOTE

If this value is set too high, the variable frequency drive may cut out because of overcurrent.

Description of choice:

If the factory setting is not adequate, load compensation must be set to enable the motor to start at the given load.



Warning: Should be set to 0% in connection with synchronous and parallel-coupled motors and in the case of quick load changes. Too high load compensation may lead to instability.

☆ = factory setting, () = display text, [] = value for use in communication via serial communication port

135 U/f-ratio (U/f RATIO)

Value:

0.00 - 20.00 at Hz ☆ Depends on unit

Function:

This parameter enables a linear shift in the ratio between output voltage (V) and output frequency (f) to ensure correct energizing of the motor and thus optimum dynamics, accuracy and efficiency. The V/f-ratio only affects the voltage characteristic if *Constant torque* [1] has been selected in parameter 101 *Torque characteristic*.

Description of choice:

Change the V/f-ratio only if it is not possible to set the correct motor data in parameters 102-109. The value programmed in the factory settings is based on idle operation.

136 Slip compensation (SLIP COMP.)

Value:

-500 - +500% of rated slip compensation ☆ 100%

Function:

Slip compensation is calculated automatically, on the basis of such data as the rated motor speed $n_{M,N}$. In this parameter, the slip compensation can be fine-tuned, thereby compensating for tolerances on the value for $n_{M,N}$. Slip compensation is only active if a selection has been made of *Speedregulation, open loop* [0] in parameter 100 *Configuration* and *Constant torque* [1] in parameter 101 *Torque characteristic*.

Description of choice:

Key in a % value.

137 DC hold voltage (DC HOLD VOLTAGE)

Value:

0 - 100% of max. DC hold voltage ☆ 0%

Function:

This parameter is used to keep the motor (holding torque) at start/stop.

Description of choice:

This parameter can only be used if a selection has been made of *DC hold* in parameter 121 *Start function* or 122 *Function at stop*. To be set as a percentage value of the max. DC hold voltage, which depends on the choice of motor.

138 Brake cut out value (Brake cut out)

Value:

0.5 - 132.0/1000.0 Hz ☆ 3.0 Hz

Function:

Select the frequency at which the external brake is released, via the output defined in parameter 323 *Relay output 1-3* or 341 *Digital output, terminal 46*.

Description of choice:

Set the required frequency.

139 Brake cut in frequency (Brake cut in)

Value:

0.5 - 132.0/1000.0 Hz ☆ 3.0 Hz

Function:

Select the frequency at which the external brake is activated; this takes place via the output defined in parameter 323 *Relay output 1-3* or 341 *Digital output terminal 46*.

Description of choice:

Set the required frequency.

140 Current, minimum value (CURRENT MIN VAL)

Value:

0 % - 100 % of inverter output current ☆ 0%

☆ = factory setting, () = display text, [] = value for use in communication via serial communication port

Function:

This is where the user selects the minimum motor current running for the mechanical brake to be released. Current monitoring is only active from stop until the point when the brake is released.

Description of choice:

This is an extra safety precaution, aimed at guaranteeing that the load is not lost during start of a lifting/lowering operation.

142 Leakage reactance X_L (LEAK. REACTANCE)

Value:

0.000 - XXX,XXX Ω ☆ Depends on choice of motor
 X_L is the sum of rotor and stator leakage reactance.

Function:

After setting of parameters 102-106 *Nameplate data*, a number of adjustments of various parameters is made automatically, including the leakage reactance X_L . The shaft performance can be improved by fine-tuning the leakage reactance X_L .



NOTE

Parameter 142 *The leakage reactance X_L* is normally not to be changed if the nameplate data has been set, parameters 102-106.

Description of choice:

X_L can be set as follows:

1. The value is stated by the motor supplier.
2. Use the factory settings of X_L , which the adjustable frequency drive itself chooses on the basis of the motor nameplate data.

143 Internal fan control (fan control)

Value:

☆ Automatic (automatic) [0]
Always switched on (always on) [1]

Always switched off (always off)

[2]

Function:

This parameter can be set so that the internal fan is automatically switched on and off. You can also set the internal fan to be permanently switched on or off.

Description of choice:

If *Automatic* [0] is selected, the internal fan is switched on or off depending on the ambient temperature and the loading of the adjustable frequency drive.

If *Always switched on* [1] or *Always switched off* [2] is selected, the internal fan will be permanently switched on or off, respectively.



NOTE

If *Always switched off* [2] is selected in combination with high switch frequency, long motor cables or high output power, the adjustable frequency drive's life span is reduced. This applies in particular to 1.5, 2, 4 and 5 HP units.

144 Gain AC brake (Gain AC brake)

Value:

1.00 - 1.50 ☆ 1.30

Function:

This parameter is used to set the AC brake. Using par. 144 it is possible to adjust the size of the generator torque that can be applied to the motor without the intermediate circuit voltage exceeding the warning level.

Description of choice:

The value is increased if a greater possible brake torque is required. If 1.0 is selected, this corresponds to the AC brake being inactive.



NOTE

If the value in par. 144 is increased, the motor current will simultaneously increase significantly when generator loads are applied. The parameter should therefore only be changed if it is guaranteed during measurement that the motor current in all

☆ = factory setting, () = display text, [] = value for use in communication via serial communication port

operating situations will never exceed the maximum permitted current in the motor.
Please note: that the current cannot be read out from the display.

146	Reset voltage vector
------------	-----------------------------

(RESET VECTOR)

Value:

- | | |
|---------------|-----|
| *Off (OFF) | [0] |
| Reset (RESET) | [1] |

Function:

When the voltage vector is reset it is set to the same starting point each time a new process commences.

Description of choice:

Select reset (1) when running unique processes each time they arise. This will enable repetitive precision when stopping to be improved. Select Off (0) for example for lifting/lowering operations or synchronous motors. It is an advantage that the motor and the variable frequency drive are always synchronized.

References & Limits

200	Output frequency range (OUT FREQ. RNG/ROT)
Value:	
☆	Only clockwise, 0 - 132 Hz (132 Hz CLOCKWISE) [0]
	Both directions, 0 - 132 Hz (132 Hz BOTH DIRECT) [1]
	Counter-clockwise only, 0 - 132 Hz (132 Hz COUNTER CLOCK) [2]
	Clockwise only, 0 - 1,000 Hz (1,000 Hz CLOCK WISE) [3]
	Both directions, 0 - 1,000 Hz (1,000 Hz BOTH DIRECT) [4]
	Counter-clockwise only, 0 - 1,000 Hz (1,000 Hz COUNTER CLOCK) [5]

Function:

This parameter guarantees protection against unwanted reversing. Furthermore, the maximum output frequency that is to apply regardless of the settings of other parameters can be selected. This parameter has no function if *Process regulation, closed-loop* has been selected in parameter 100 *Configuration*.

Description of choice:

Select the required direction of rotation as well as the maximum output frequency. Please note that if *Clockwise only* [0]/[3] or *Counter-clockwise only* [2]/[5] is selected, the output frequency will be limited to the range $f_{MIN}-f_{MAX}$. If *Both directions* [1]/[4] is selected, the output frequency will be limited to the range $\pm f_{MAX}$ (the minimum frequency is of no significance).

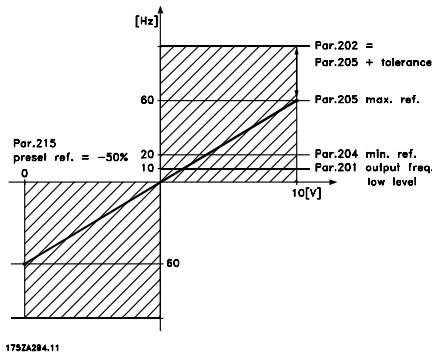

201 Output frequency low limit, f_{MIN} (MIN OUTPUT FREQ)

Value:

0.0 - f_{MAX} ☆ 0.0 Hz

Function:

In this parameter, a minimum motor frequency limit can be selected that corresponds to the minimum speed at which the motor is allowed to run. If *Both directions* has been selected in parameter 200 *Output frequency range*, the minimum frequency is of no significance.

Description of choice:

The value chosen can range from 0.0 Hz to the frequency set in parameter 202 *Output frequency high limit, f_{MAX}* .

202 Output frequency high limit, f_{MAX} (max. output freq)

Value:

f_{MIN} - 132/1,000 Hz (par. 200 *Output frequency range*) ☆ 132 Hz

Function:

In this parameter, a maximum output frequency limit can be selected that corresponds to the highest speed at which the motor is allowed to run.



NOTE

The output frequency of the adjustable frequency drive can never assume a value higher than 1/10 of the switching frequency (parameter 411 *Switching frequency*).

Description of choice:

A value can be selected from f_{MIN} to the value chosen in parameter 200 *Output frequency range*.

☆ = factory setting, () = display text, [] = value for use in communication via serial communication port

**203 Reference range
(REFERENCE RANGE)**
Value:

- ★ Min. reference - Max reference (min - max) [0]
- Max. reference - Max. reference
- (-max - +max) [1]

Function:

In this parameter you select whether the reference signal must be positive or whether it can be both positive and negative. The minimum limit may be a negative value, unless in parameter 100 *Configuration* a selection has been made of *Speed regulation, closed loop*. You should select *Min ref. - Max. ref.* [0], if *Process regulation, closed loop* [3] has been selected in parameter 100 *Configuration*.

Description of choice:

Select the required range.

**204 Minimum reference, Ref_{MIN}
(Min.reference)**
Value:

- Par. 100 *Config. = Open loop*
- [0].-100,000.000 - par. 205 Ref_{MAX} ★ 0.000 Hz
- Par. 100 *Config. = Closed loop* [1]/[3].-
- Par. 414 *Minimum feedback* - par. 205 ★ 0.000
- Ref_{MAX} rpm/par 416

Function:

Minimum reference is an expression of the minimum possible value of the total of all references. If in parameter 100 *Configuration*, *Speed regulation, closed loop* [1] or *Process regulation, closed loop* [3] is selected, the minimum reference is limited by parameter 414 *Minimum feedback*. Minimum reference is ignored if the local reference is active.

The reference unit can be defined from the following table:

Par. 100 <i>Configuration</i>	Unit
Open loop [0]	Hz
Speed reg, closed loop [1]	rpm
Process reg, closed loop [3]	Par. 416

Description of choice:

The minimum reference is preset if the motor has to run at a minimum speed, regardless of whether the resulting reference is 0.

**205 Maximum reference, Ref_{MAX}
(max.reference)**
Value:

- Par. 100 *Config. = Open loop*
- [0].Par. 204 Ref_{MIN} - 1000.000 Hz ★ 50.000 Hz
- Par. 100 *Config. = Closed loop* [1]/
- [3]. Par. 204 Ref_{MIN} - Par. 415 *Max.* ★ 50.000
- feedback* rpm/par 416

Function:

The maximum reference gives the highest value that can be assumed by the sum of all references. If *Closed loop* [1]/[3] is selected in parameter 100 *Configuration* the maximum reference cannot exceed the value in parameter 415 *Maximum feedback*.

Maximum reference is ignored if the local reference is active.

The reference unit can be defined from the following table:

Par. 100 <i>Configuration</i>	Unit
Open loop [0]	Hz
Speed reg, closed loop [1]	rpm
Process reg, closed loop [3]	Par. 416

Description of choice:

Maximum reference is set, if the speed of the motor is to be max. the set value, regardless of the whether the resulting reference is greater than the maximum reference.

**206 Ramp type
(Ramp type)**
Value:

- ★ Linear (Linear) [0]
- Sine shaped (S-SHAPED) [1]
- Sine² shaped (S-SHAPED 2) [2]

★ = factory setting, () = display text, [] = value for use in communication via serial communication port

VLT® 2800 Series

Function:

You can choose between a linear, a sine-shaped and a sine²-shaped ramp process.

Description of choice:

Select the required ramp type depending on requirements for the acceleration/deceleration process.

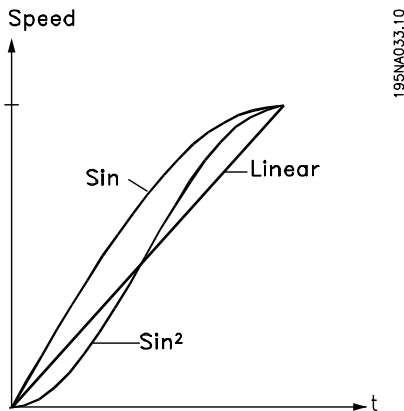

207 Ramp-up time 1

(Ramp-up time 1)

Value:

0.02 - 3600.00 sec ★ 3.00 sec (VLT 2803-2875)
10.00 sec (VLT 2880-2882)

Function:

The ramp-up time is the acceleration time from 0 Hz to the rated motor frequency $f_{M,N}$ (parameter 104 *Motor frequency, $f_{M,N}$*). It is assumed that the output current will not reach the current limit (set in parameter 221 *Current limit I_{LM}*).

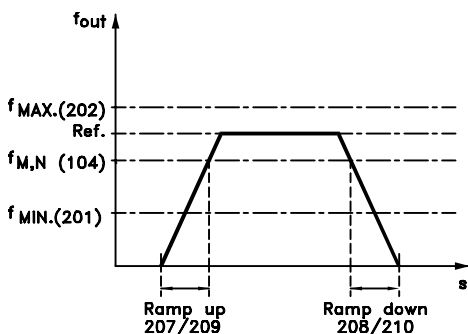

Description of choice:

Set the required ramp-up time.

208 Ramp-down time 1

(ramp down time 1)

Value:

0.02 - 3600.00 sec ★ 3.00 sec (VLT 2803-2875)
10.00 sec (VLT 2880-2882)

Function:

The ramp-down time is the deceleration time from the rated motor frequency $f_{M,N}$ (parameter 104 *Motor frequency, $f_{M,N}$*) to 0 Hz, provided no overvoltage arises in the inverter because of generating operation of the motor.

Description of choice:

Set the required ramp-down time.

209 2 Ramp-up time

(2 Ramp-up time)

Value:

0.02 - 3600.00 sec. ★ 3.00 sec (VLT 2803-2875)
10.00 sec (VLT 2880-2882)

Function:

See description of parameter 207 *Ramp-up time 1*.

Description of choice:

Set the required ramp-up time. Shift from ramp 1 to ramp 2 by activating *Ramp 2* via a digital input.

210 2 Ramp-down time

(ramp down time 2)

Value:

0.02 - 3600.00 sec. ★ 3.00 sec (VLT 2803-2875)
10.00 sec (VLT 2880-2882)

Function:

See description of parameter 208 *Ramp-down time 1*.

Description of choice:

Set the required ramp-down time. Shift from ramp 1 to ramp 2 by activating *Ramp 2* via a digital input.

211 Jog ramp time

(Jog ramp time)

Value:

0.02 - 3600.00 sec. ★ 3.00 sec (VLT 2803-2875)

★ = factory setting, () = display text, [] = value for use in communication via serial communication port

10.00 sec (VLT 2880-2882)

Function:

The jog ramp time is the acceleration/deceleration time from 0 Hz to the rated motor frequency $f_{M,N}$ (parameter 104 *Motor frequency, $f_{M,N}$*). It is assumed that the output current will not reach the current limit (set in parameter 221 *Current limit I_{LIM}*).

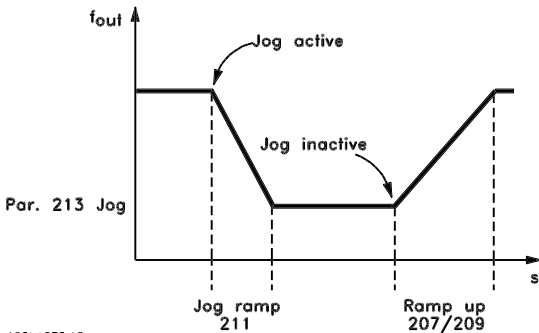

195NA075.10

The jog ramp time starts if a jog-signal is given via the LCP control panel, one of the digital inputs or the serial communication port.

Description of choice:

Set the required ramp time.

212 Quick-stop ramp-down time (Q STOP RAMP TIME)

Value:

0.02 - 3600.00 sec. ☆ 3.00 sec (VLT 2803-2875)
10.00 sec (VLT 2880-2882)

Function:

The quick-stop ramp-down time is the deceleration time from the rated motor frequency to 0 Hz, provided no overvoltage arises in the inverter because of generating operation of the motor, or if the generated current exceeds the current limit in parameter 221 *Current limit I_{LIM}* . Quick-stop is activated via one of the digital inputs or the serial communication.

Description of choice:

Set the required ramp-down time.

213 Jog frequency

(Jog frequency)

Value:

0.0 - Par. 202 Output frequency high limit, f_{MAX} ☆ 10.0 Hz

Function:

Jog frequency f_{JOG} means a fixed output frequency that the variable frequency drive supplies to the motor when the Jog function is activated. Jog can be activated via the digital inputs, serial communication or via the LCP control panel, on the condition that this is active in parameter 015 *Local jog*.

Description of choice:

Set the required frequency.

214 Reference function

(Ref function)

Value:

- ☆ Sum (sum) [0]
- Relative (relative) [1]
- External/preset (external/preset) [2]

Function:

It is possible to define how preset references are to be added to the other references; for this purpose, use *Sum* or *Relative*. It is also possible by using the *External/preset* to select whether a shift between external references and preset references is required.

External reference is the sum of the analog references, pulse references and any references from serial communication.

Description of choice:

If *Sum* [0] is selected, one of the adjusted preset references (parameters 215-218 *Preset reference*) is summarized as a percentage of the reference range ($Ref_{MIN} - Ref_{MAX}$), added to the other external references.

If *Relative* [1] is selected, one of the added preset references (parameters 215-218 *Preset reference*) is summarized as a percentage of the sum of present external references.

If *External/preset* [2] is selected, it is possible via a digital input to shift between external references or preset

☆ = factory setting, () = display text, [] = value for use in communication via serial communication port

references. Preset references will be a percentage value of the reference range.



NOTE

If Sum or Relative is selected, one of the preset references will always be active. If the preset references are to be without influence, they must be set to 0% (factory setting).

215	Preset reference 1 (PRESET REF. 1)
216	Preset reference 2 (PRESET REF. 2)
217	Preset reference 3 (PRESET REF. 3)
218	Preset reference 4 (PRESET REF. 4)

Value:

-100.00% - +100.00% ☆ 0.00%
of the reference range/external reference

Function:

Four different preset references can be programmed in parameters 215-218 *Preset reference*.

The preset reference is stated as a percentage of the reference range (Ref_{MIN} - Ref_{MAX}) or as a percentage of the other external references, depending on the choice made in parameter 214 *Reference function*.

The choice between preset references can be made via the digital inputs or via serial communication.

Preset ref., msb	Preset ref. lsb	
0	0	Preset ref. 1
0	1	Preset ref. 2
1	0	Preset ref. 3
1	1	Preset ref. 4

Description of choice:

Set the preset reference(s) that is/are to be the options.

219	Catch up/Slow down reference (Catch up/Slw dwn)
------------	--

Value:

0.00 - 100% of the given reference ☆ 0.00%

Function:

In this parameter, the percentage value can be set which will either be added to or deducted from the remote-controlled references.

The remote-controlled reference is the sum of preset references, analog references, pulse reference and any references from serial communication.

Description of choice:

If *Catch up* is active via a digital input, the percentage value in parameter 219 *Catch up/Slow down reference* will be added to the remote-controlled reference. If *Slow down* is active via a digital input, the percentage value in parameter 219 *Catch up/Slow down reference* will be deducted from the remote-controlled reference.

221	Current limit, I_{LIM} (current limit)
------------	---

Value:

0 - XXX.X % of par. 105 ☆ 160 %

Function:

In this parameter, the maximum output current I_{LIM} is set. The factory-set value corresponds to the maximum output current I_{MAX}. If the current limit is to be used as motor protection, set the rated motor current. If the current limit is set above 100% (the rated output current of the variable frequency drive, I_{INV}), the variable frequency drive can only handle a load intermittently, i.e. for short periods at a time. After the load has been higher than I_{INV}, it must be ensured that for a period the load is lower than I_{INV}. Please note that if the current limit is set at a lower value than I_{INV}, the acceleration torque will be reduced to the same extent.

Description of choice:

Set the required maximum output current I_{LIM}.

223	Warning: Low current, I_{Low} (warn. current lo)
------------	---

Value:

0.0 - par. 224 *Warning: High current*,
I_{HIGH} ☆ 0.0 A

Function:

If the output current falls below the preset limit I_{Low} a warning is given.

☆ = factory setting, () = display text, [] = value for use in communication via serial communication port

Parameters 223-228 *Warning functions* are out of function during ramp-up after a start command and after a stop command or during stop. The warning functions are activated when the output frequency reaches the resulting reference. The signal outputs can be programmed to give a warning signal via terminal 46 and via the relay output.

Description of choice:

The lower signal limit of the output current I_{LOW} must be programmed within the normal working range of the unit.

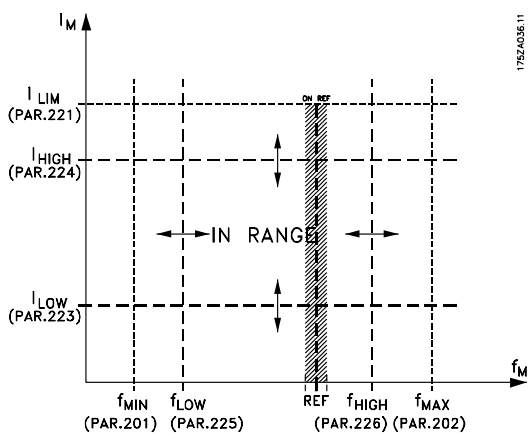

224 Warning: High current, I_{HIGH} (warn. current hi)

Value:

0 - I_{MAX} ★ I_{MAX}

Function:

If the output current exceeds the preset limit I_{HIGH} a warning is given. Parameters 223-228 *Warning functions* do not work during ramp-up after a start command and after stop command or during stop. The warning functions are activated when the output frequency has reached the resulting reference. The signal outputs can be programmed to give a warning signal via terminal 46 and via the relay output.

Description of choice:

The output current's upper signal limit I_{HIGH} must be programmed within the variable frequency drive's normal operating range. See drawing at parameter 223 *Warning: Low current, I_{LOW}* .

225 Warning: Low frequency, f_{LOW} (warn.freq. low)

Value:

0.0 - par. 226
Warn.: High frequency, f_{HIGH} ★ 0.0 Hz

Function:

If the output frequency falls below the preset limit f_{LOW} , a warning is given. Parameters 223-228 *Warning functions* are out of function during ramp-up after a start command and after stop command or during stop. The warning functions are activated when the output frequency has reached the resulting reference. The signal outputs can be programmed to give a warning signal via terminal 46 and via the relay output.

Description of choice:

The lower signal limit of the output frequency f_{LOW} must be programmed within the normal operating range of the variable frequency drive. See drawing at parameter 223 *Warning: Low current, I_{LOW}* .

226 Warning: High frequency f_{HIGH} (warn.freq.high)

Value:

Par. 200 *Frequency range* = 0-132 Hz
[0]/[1].par. 225 f_{LOW} - 132 Hz ★ 132.0 Hz
Par. 200 *Frequency range* = 0-1000 Hz
[2]/[3].par. 225 f_{LOW} - 1000 Hz ★ 132.0 Hz

Function:

If the output frequency exceeds the preset limit f_{HIGH} a warning is given. Parameters 223-228 *Warning functions* do not work during ramp-up after a start command and after stop command or during stop. The warning functions are activated when the output frequency has reached the resulting reference. The signal outputs can be programmed to give a warning signal via terminal 46 and via the relay output.

Description of choice:

The output frequency's upper signal limit f_{HIGH} must be programmed within the variable frequency drive's normal operating range. See drawing at parameter 223 *Warning: Low current, I_{LOW}* .

★ = factory setting, () = display text, [] = value for use in communication via serial communication port

VLT® 2800 Series

227 Warning: Low feedback, FB_{LOW} (warn.feedb. low)

Value:

-100,000.000 - par. 228 Warn.:
 FB_{HIGH} ★ -4000.000

Function:

If the feedback signal falls below the preset limit FB_{LOW} , a warning is given. Parameters 223-228 *Warning functions* are out of function during ramp-up after a start command and after a stop command or during stop. The warning functions are activated when the output frequency has reached the resulting reference. The signal outputs can be programmed to give a warning signal via terminal 46 and via the relay output. The unit for feedback in Closed loop is programmed in parameter 416 *Process units*.

Description of choice:

Set the required value within the feedback range (parameter 414 *Minimum feedback, FB_{MIN}* and 415 *Maximum feedback, FB_{MAX}*).

228 Warning: High feedback, FB_{HIGH} (warn.feedb high)

Value:

Par. 227 Warn.: FB_{LOW} - 100,000.000 ★ 4000.000

Function:

If the feedback signal gets above the preset limit FB_{HIGH} , a warning is given. Parameters 223-228 *Warning functions* are out of function during ramp-up after a start command and after a stop command or during stop. The warning functions are activated when the output frequency has reached the resulting reference. The signal outputs can be programmed to give a warning signal via terminal 46 and via the relay output. The unit for feedback in Closed loop is programmed in parameter 416 *Process units*.

Description of choice:

Set the required value within the feedback range (parameter 414 *Minimum feedback, FB_{MIN}* and 415 *Maximum feedback, FB_{MAX}*).

229 Frequency bypass, bandwidth (FREQ BYPASS B.W.)

Value:

0 (OFF) - 100 Hz ★ 0 Hz

Function:

Some systems call for some output frequencies to be avoided because of mechanical resonance problems in the system. In parameters 230-231 *Frequency bypass*, these output frequencies can be programmed. In this parameter, a bandwidth can be defined on either side of these frequencies.

Description of choice:

The frequency set in this parameter will be centered around parameters 230 *Frequency bypass 1* and 231 *Frequency bypass 2*.

230 Frequency bypass 1 (FREQ. BYPASS 1)

231 Frequency bypass 2 (FREQ. BYPASS 2)

Value:

0 - 1000 Hz ★ 0.0 Hz

Function:

Some systems call for some output frequencies to be avoided because of mechanical resonance problems in the system.

Description of choice:

Enter the frequencies to be avoided. See also parameter 229 *Frequency bypass, bandwidth*.

Inputs and Outputs

Digital inputs	Term. no.	18 ¹	19 ¹	27	29	33
	par. no.	302	303	304	305	307
Value:						
No function	(NO OPERATION)	[0]	[0]	[0]	[0]	★ [0]
Reset	(RESET)	[1]	[1]	[1]	[1]	[1]
Coasting stop inverse	(MOTOR COAST INVERSE)	[2]	[2]	[2]	[2]	[2]
Reset and coasting inverse	(RESET AND COAST INV.)	[3]	[3]	★ [3]	[3]	[3]
Quick-stop inverse	(QUICK-STOP INVERSE)	[4]	[4]	[4]	[4]	[4]
DC braking inverse	(DC BRAKE INVERSE)	[5]	[5]	[5]	[5]	[5]
Stop inverse	(STOP INVERSE)	[6]	[6]	[6]	[6]	[6]
Start	(START)	★ [7]	[7]	[7]	[7]	[7]
Pulse start	(LATCHED START)	[8]	[8]	[8]	[8]	[8]
Reversing	(REVERSING)	[9]	★ [9]	[9]	[9]	[9]
Reversing and start	(START REVERSING)	[10]	[10]	[10]	[10]	[10]
Start clockwise	(ENABLE FORWARD)	[11]	[11]	[11]	[11]	[11]
Start counter-clockwise	(ENABLE REVERSE)	[12]	[12]	[12]	[12]	[12]
Jog	(JOGGING)	[13]	[13]	[13]	★ [13]	[13]
Freeze reference	(FREEZE REFERENCE)	[14]	[14]	[14]	[14]	[14]
Freeze output frequency	(FREEZE OUTPUT)	[15]	[15]	[15]	[15]	[15]
Speed up	(SPEED UP)	[16]	[16]	[16]	[16]	[16]
Slow	(SLOW)	[17]	[17]	[17]	[17]	[17]
Catch-up	(CATCH-UP)	[19]	[19]	[19]	[19]	[19]
Slow-down	(SLOW-DOWN)	[20]	[20]	[20]	[20]	[20]
Ramp 2	(RAMP 2)	[21]	[21]	[21]	[21]	[21]
Preset ref, LSB	(PRESET REF, LSB)	[22]	[22]	[22]	[22]	[22]
Preset ref, MSB	(PRESET REF, MSB)	[23]	[23]	[23]	[23]	[23]
Preset reference on	(PRESET REFERENCE ON)	[24]	[24]	[24]	[24]	[24]
Thermistor	(THERMISTOR)	[25]	[25]	[25]	[25]	
Precise stop, inverse	(PRECISE STOP INV.)	[26]	[26]			
Precise start/stop	(PRECISE START/STOP)	[27]	[27]			
Pulse reference	(PULSE REFERENCE)					[28]
Pulse feedback	(PULSE FEEDBACK)					[29]
Pulse input	(PULSE INPUT)					[30]
Selection of Set-up, lsb	(SET-UP SELECT LSB)	[31]	[31]	[31]	[31]	[31]
Selection of Set-up, msb	(SET-UP SELECT MSB)	[32]	[32]	[32]	[32]	[32]
Reset and start	(RESET AND START)	[33]	[33]	[33]	[33]	[33]
Pulse counter start	(PULSE COUNTER START)	[34]	[34]			

1. All functions on terminals 18 and 19 are controlled by an interrupter, which means that the repetitive accuracy of the response time is constant. Can be used for start/stop, set-up switch, and especially for changing digital preset, i.e., to obtain a reproducible stop point when using creep speed. For further information, see VLT 2800 Precise Stop Instruction, MI.28.CX.02.

Function:

In these parameters, 302-307 *Digital inputs*, it is possible to choose between the different enabled functions related to the digital inputs (terminals 18-33).

★ = factory setting, () = display text, [] = value for use in communication via serial communication port

Description of choice:

No operation is selected if the adjustable frequency drive is not to react to signals transmitted to the terminal.

Reset resets the adjustable frequency drive after an alarm; however, a few alarms cannot be reset (trip locked) without first disconnecting the line supply and reconnecting it. See table under *List of warnings and alarms*. Reset is activated on the leading edge of the signal.

Coasting stop inverse is used for making the adjustable frequency drive "let go" of the motor immediately (output transistors are "turned off"), which means that the motor runs freely to a stop. Logic '0' leads to coasting to stop.

Reset and coasting inverse are used to activate motor coast simultaneously with reset. Logical '0' means motor coast stop and reset. Reset is activated on the falling edge.

Quick stop inverse is used for activating the quick stop ramp-down set in parameter 212 *Quick stop ramp-down time*. Logic '0' leads to quick stop.

DC braking inverse is used for stopping the motor by energizing it with a DC voltage for a given time; see parameters 126, 127 and 132 *DC brake*. Please note that this function is only active if the value in parameter 126 *DC braking time* and 132 *DC brake voltage* is different from 0. Logic '0' leads to DC braking.

Stop inverse, a logic '0' means that the motor speed is ramped down to stop via the selected ramp.



None of the stop commands mentioned above are to be used as repair switches. Note that the adjustable frequency drive has more voltage inputs than L1, L2 and L3 when the DC bus terminals are used. Make sure that all voltage inputs are disconnected and that the prescribed time (4 minutes.) has passed before repair work is commenced.

Start is selected if a start/stop command is required. Logic '1' = start, logic '0' = stop.

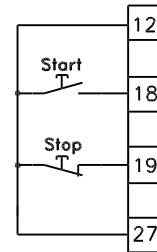

195NA029.11

Latched start - if a pulse is applied for at least 14 ms, the adjustable frequency drive will start the motor, provided no stop command has been given. The motor can be stopped by briefly activating *Stop inverse*.

Reversing is used for changing the direction of rotation of the motor shaft. Logic '0' will not lead to reversing. Logic '1' will lead to reversing. The reverse signal only changes the direction of rotation, it does not activate the start. Is not active at *Process regulation, closed-loop*. See also parameter 200 *Output frequency range/direction*.

Reversing and start is used for start/stop and for reversing with the same signal. No active start command is allowed at the same time. Acts as latch start reversing, provided latch start has been chosen for terminal 18. Is not active for *Process regulation, closed-loop*. See also parameter 200 *Output frequency range/direction*.

Start clockwise is used if you want the motor shaft only to be able to rotate clockwise when started. Should not be used for *Process regulation, closed-loop*.

Start counter-clockwise is used if you want the motor shaft only to be able to rotate counter-clockwise when started. Should not be used for *Process regulation, closed-loop*. See also parameter 200 *Output frequency range/direction*.

Jog is used to override the output frequency to the jog frequency set in parameter 213 *Jog frequency*. Jog is active regardless of whether a start command has been given, yet not when *Coast stop, Quick stop* or *DC braking* are active.

Freeze reference freezes the present reference. The reference can now only be changed via *Speed up* and *Slow*. If *freeze reference* is active, it will be saved after a stop command and in the event of line failure.

Freeze output freezes the present output frequency (in Hz). The output frequency can now only be changed via *Speed up* and *Slow*.

★ = factory setting, () = display text, [] = value for use in communication via serial communication port



NOTE

If *Freeze output* is active, the adjustable frequency drive can only be stopped by selecting *Motor coast*, *Quick stop*, or *DC braking* via a digital input.

Speed up and *Slow* are selected if digital control of the up/down speed is required. This function is only active if *Freeze reference* or *Freeze output frequency* has been selected.

If *Speed up* is active, the reference or output frequency will be increased; and if *Slow* is active, the reference or output frequency will be reduced. The output frequency is changed via the preset ramp times in parameters 209-210 *Ramp 2*.

One pulse (logic '1' minimum high for 14 ms and a minimum break time of 14 ms) will lead to a speed change of 0.1% (reference) or 0.1 Hz (output frequency). Example:

Term	Term.	Freeze ref/ freeze outp.	Function
.29	33		
0	0	1	No speed change
0	1	1	Speed up
1	0	1	Slow
1	1	1	Slow

Freeze reference can be changed even if the adjustable frequency drive has stopped. The reference will also be saved if line power is disconnected.

Catch-up/Slow-down is selected if the reference value is to be increased or reduced by a programmable percentage value set in parameter 219 *Catch-up/Slow-down reference*.

Slow-down	Catch-up	Function
0	0	Unchanged speed
0	1	Increase by % value
1	0	Reduce by % value
1	1	Reduce by % value

Ramp 2 is selected if a shift between ramp 1 (parameters 207-208) and ramp 2 (parameters 209-210) is required. Logic '0' leads to ramp 1 and logic '1' leads to ramp 2.

Preset reference, lsb and *Preset reference, msb* makes it possible to select one of the four preset references; see the table below:

Preset ref. msb	Preset ref. lsb	Function
0	0	Preset ref. 1
0	1	Preset ref. 2
1	0	Preset ref. 3
1	1	Preset ref. 4

Preset reference on is used for shifting between a remote-controlled reference and a preset reference. It is assumed that *External/preset [2]* has been selected in parameter 214 *Reference function*. Logic '0' means that remote-controlled references are active, while logic '1' means that one of the four preset references is active, as can be seen from the table above.

Thermistor is to be selected if a possibly integrated thermistor in the motor is to be able to stop the adjustable frequency drive if the motor overheats. The cut-out value is 3 kΩ.

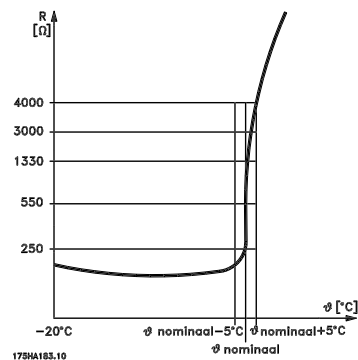

If a motor features a Klixon thermal switch instead, this can also be connected to the input. If motors operate in parallel, the thermistors/thermal switches can be connected in series (total resistance lower than 3 kΩ). Parameter 128 *Motor thermal protection* must be programmed for *Thermistor warning [1]* or *Thermistor trip [2]*, and the thermistor is to be connected between a digital input and terminal 50 (+10 V supply).

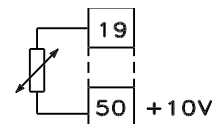

195NA077.10

Precise stop, inverse is selected to obtain a high degree of accuracy when a stop command is repeated. A logic 0 means that the motor speed is ramped down to stop via the selected ramp.

★ = factory setting, () = display text, [] = value for use in communication via serial communication port

Precise start/stop is selected to obtain a high degree of accuracy when a start and stop command is repeated.

Pulse reference is selected if the reference signal applied is a pulse train (frequency). 0 Hz corresponds to parameter 204 *Minimum reference*, Ref_{MIN} . The frequency, set in parameter 327 *Pulse reference/feedback*, corresponds to parameter 205 *Maximum reference* Ref_{MAX} .

Pulse feedback is selected if the feedback signal used is a pulse train (frequency). In parameter 327 *Pulse reference/feedback*, the maximum pulse feedback frequency is set.

Pulse input is selected if a specific number of pulses must lead to a *Precise stop*; see parameter 343 *Precise stop* and parameter 344 *Counter value*.

Selection of Set-up, lsb and *Selection of Set-up, msb* provides the option of selecting one of the four set-ups. It is, however, a condition that parameter 004 is set to *Multi-set-up*.

Reset and start can be used as a start function. If 24 V are connected to the digital input, this will cause the adjustable frequency drive to reset, and the motor will ramp up to the preset reference.

Pulse counter start is used to start a counter stop sequence with a pulse signal. The pulse width must be at least 14 ms and not longer than the count period. See also parameter 343 and the instruction, MI28CXYY.

308 Terminal 53, analogue input voltage (AI [V]53FUNCT.)	
Value:	
No function (NO OPERATION)	[0]
★ Reference (reference)	[1]
Feedback (feedback)	[2]
Wobble (WOBB.DELTA FREQ [%])	[10]
Function:	
In this parameter, it is possible to select the function required to be connected to terminal 53. Scaling of the input signal is made in parameter 309 <i>Terminal 53, min. scaling</i> and parameter 310 <i>Terminal 53, max. scaling</i> .	

Description of choice:

No function [0]. Is selected if the adjustable frequency drive is not to react to signals connected to the terminal. *Reference* [1]. If this function is selected, the reference can be changed by means of an analog reference signal. If reference signals are connected to more than one input, these reference signals must be added up. If a voltage feedback signal is connected, select *Feedback* [2] on terminal 53.

Wobble [10]

The delta frequency can be controlled by the analog input. If *WOBB.DELTA FREQ* is selected as analog input (par. 308 or par. 314) the value selected in par. 702 equals 100 % analog input.

Example: Analog input = 4-20 mA, Delta freq. par. 702 = 5 Hz • 4 mA = 0 Hz and 20 mA = 5 Hz. If this function is chosen, see Wobble Instruction MI28JXYY for further information.

309 Terminal 53 Min. scaling
(AI 53 SCALE LOW)
Value:

0.0 - 10.0 Volt ★ 0.0 Volt

Function:

This parameter is used for setting the signal value that is to correspond to the minimum reference or the minimum feedback, parameter 204 *Minimum reference*, Ref_{MIN} / 414 *Minimum feedback*, FB_{MIN} .

Description of choice:

Set the required voltage value. For reasons of accuracy, compensation should be made for voltage loss in long signal cables. If the Time out function is to be used (parameter 317 *Time out* and 318 *Function after time out*), the value set must be higher than 1 Volt.

310 Terminal 53 Max. scaling
(AI 53 SCALE HIGH)
Value:

0 - 10.0 Volt ★ 10.0 Volt

Function:

This parameter is used for setting the signal value that is to correspond to the maximum reference value or

★ = factory setting, () = display text, [] = value for use in communication via serial communication port

VLT® 2800 Series

maximum feedback, parameter 205 *Maximum reference, Ref_{MAX}* / 414 *Maximum feedback, FB_{MAX}*.

Description of choice:

Set the required voltage value. For reasons of accuracy, compensation should be made for voltage losses in long signal cables.

314 Terminal 60, analogue input current (AI [mA] 60 FUNCT)

Value:

No function (no operation)	[0]
Reference (reference)	[1]
★ Feedback (feedback)	[2]
Wobble (WOBB.DELTA FREQ [%])	[10]

Function:

This parameter allows a choice between the different functions available for the input, terminal 60. Scaling of the input signal is effected in parameter 315 *Terminal 60, min. scaling* and parameter 316 *Terminal 60, max. scaling*.

Description of choice:

No function [0]. Is selected if the adjustable frequency drive is not to react to signals connected to the terminal. *Reference* [1]. If this function is selected, the reference can be changed by means of an analog reference signal. If reference signals are connected to more than one input, these reference signals must be added up.

If one current feedback signal is connected, select *Feedback* [2] on terminal 60.

Wobble [10]

The delta frequency can be controlled by the analog input. If *WOBB.DELTA FREQ* is selected as analog input (par. 308 or par. 314) the value selected in par. 702 equals 100 % analog input.

Example: Analog input = 4-20 mA, Delta freq. par. 702 = 5 Hz • 4 mA = 0 Hz and 20 mA = 5 Hz. If this function is chosen, see Wobble Instruction MI28JXYY for further information.

315 Terminal 60 Min. scaling

(AI 60 SCALE LOW)

Value:

0.0 - 20.0 mA ★ 4.0 mA

Function:

In this parameter, you can set the signal value that will correspond to the minimum reference or minimum feedback, parameter 204 *Minimum reference, Ref_{MIN}* / 414 *Minimum feedback, FB_{MIN}*.

Description of choice:

Set the required current value. If the Timeout function is to be used (parameter 317 *Time out* and 318 *Function after time out*), the value set must be higher than 2 mA.

316 Terminal 60 Max. scaling

(AI 60 SCALE HIGH)

Value:

0.0 - 20.0 mA ★ 20.0 mA

Function:

This parameter is used for setting the signal value that is to correspond to the maximum reference value, parameter 205 *Maximum reference value, Ref_{MAX}*.

Description of choice:

Set the required current value.

317 Time out

(LIVE ZERO TIME O)

Value:

1 - 99 sec. ★ 10 sec.

Function:

If the signal value of the reference or feedback signal connected to one of the input terminals 53 or 60 falls below 50 % of the minimum scaling for a period longer than the time set, the function selected in parameter 318 *Function after time out* will be activated. This function is only active if in parameter 309 *Terminal 53, min. scaling* a value higher than 1 Volt has been selected, or if in parameter 315 *Terminal 60, min. scaling* a value higher than 2 mA has been selected.

★ = factory setting, () = display text, [] = value for use in communication via serial communication port

VL^T® 2800 Series

Description of choice:

Set the required time.

318 Function after time out (LIVE ZERO FUNCT.)

Value:

★ No operation (NO OPERATION)	[0]
Freeze output frequency (FREEZE OUTPUT FREQ.)	[1]
Stop (stop)	[2]
Jog (jog)	[3]
Max. speed (MAX SPEED)	[4]
Stop and trip (STOP AND TRIP)	[5]

Function:

This parameter allows a choice of the function to be activated after the expiry of the Time out (parameter 317 *Time out*). If a time-out function occurs at the same time as a bus time-out function (parameter 513 *Bus time interval function*), the time-out function in parameter 318 will be activated.

Description of choice:

The output frequency of the adjustable frequency drive can be:

- frozen at the present frequency [1]
- overruled to stop [2]
- overruled to jog frequency [3]
- overruled to max. output frequency [4]
- overruled to stop with subsequent trip [5]

319 Analog output terminal 42 (AO 42 FUNCTION)

Value:

No function (NO OPERATION)	[0]
External reference min.-max. 0-20 mA (ref min-max = 0-20 mA)	[1]
External reference min.-max. 4-20 mA (ref min-max = 4-20 mA)	[2]
Feedback min.-max. 0-20 mA (fb min-max = 0-20 mA)	[3]
Feedback min.-max. 4-20 mA	[4]

(fb min-max = 4-20 mA)

Output frequency 0-max 0-20 mA
(0-fmax = 0-20 mA) [5]

Output frequency 0-max 4-20 mA
(0-fmax = 4-20 mA) [6]

★ Output current 0-I_{INV} 0-20 mA
(0-iinv = 0-20 mA) [7]

Output current 0-I_{IINV} 4-20 mA
(0-iinv = 4-20 mA) [8]

Output power 0-P_{M,N} 0-20 mA
(0-Pnom = 0-20 mA) [9]

Output power 0-P_{M,N} 4-20 mA
(0-Pnom = 4-20 mA) [10]

Inverter temperature 68-212 °F [20-100 °C]
0-20 mA

(TEMP 20-100 C=0-20 mA) [11]

Inverter temperature 68-212 °F [20-100 °C]
4-20 mA

(TEMP 20-100 C=4-20 mA) [12]

Function:

The analog output can be used for stating a process value. It is possible to choose two types of output signals 0-20 mA or 4-20 mA.

If used as a voltage output (0-10 V), a pull-down resistor of 500 Ω must be fitted to common (terminal 55). If the output is used as a current output, the resulting resistance from the equipment connected may not exceed 500 Ω.

Description of choice:

No function. Is selected if the analog output is not to be used.

External Ref_{MIN} - Ref_{MAX} 0-20 mA/4-20 mA.

An output signal is obtained, which is proportional to the resulting reference value in the interval Minimum reference, Ref_{MIN} - Maximum reference, Ref_{MAX} (parameters 204/205).

FB_{MIN}-FB_{MAX} 0-20 mA/ 4-20 mA.

An output signal is obtained, which is proportional to the feedback value in the interval Minimum feedback, FB_{MIN} - Maximum feedback, FB_{MAX} (parameter 414/415).

0-f_{MAX} 0-20 mA/4-20 mA.

★ = factory setting, () = display text, [] = value for use in communication via serial communication port

An output signal is obtained, which is proportional to the output frequency in the interval 0 - f_{MAX} (parameter 202 *Output frequency, high limit, f_{MAX}*).

0 - I_{INV} 0-20 mA/4-20 mA.

An output signal is obtained, which is proportional to the output current in the interval 0 - I_{INV}

0 - $P_{M,N}$ 0-20 mA/4-20 mA.

An output signal is obtained, which is proportional to the present output power. 20 mA corresponds to the value set in parameter 102 *Motor power, $P_{M,N}$* .

0 - $Temp_{MAX}$ 0-20 mA/4-20 mA.

An output signal is obtained, which is proportional to the present heatsink temperature. 0/4 mA corresponds to a heatsink temperature of less than 68 °F [20 °C], and 20 mA corresponds to 100 °C.

Feedback higher than FB_{LOW} par. 227 (above feedback low)	[15]
Feedback lower than FB_{HIGH} par. 228 (under feedback high)	[16]
Relay 123 (RELAY 123)	[17]
Reversing (REVERSE)	[18]
Thermal warning (THERMAL WARNING)	[19]
Local operation (LOCAL MODE)	[20]
Out of frequency range par. 225/226 (out of freq. range)	[22]
Out of current range (out of current range)	[23]
Out of feedback range (out of fdbk. range)	[24]
Mechanical brake control (Mech. brake control)	[25]
Control word bit 11 (control word bit 11)	[26]

323	Relay output 1-3
(RELAY 1-3 FUNCT.)	

Value:	
No function (no operation)	[0]
★ Unit ready (unit ready)	[1]
Enable/no warning (enable/no warning)	[2]
Running (RUNNING)	[3]
Running in reference, no warning (run on ref/no warn)	[4]
Running, no warnings (RUNNING/NO WARNING)	[5]
Running in reference range, no warnings (RUN IN RANGE/ NO WARN)	[6]
Ready - AC line voltage within range (RDY NO OVER/UNDERVOL)	[7]
Alarm or warning (ALARM OR WARNING)	[8]
Current higher than current limit, par. 221 (Current limit)	[9]
Alarm (ALARM)	[10]
Output frequency higher than f_{LOW} par. 225 (above frequency low)	[11]
Output frequency lower than f_{HIGH} par. 226 (below frequency high)	[12]
Output current higher than I_{LOW} par. 223 (above current low)	[13]
Output current lower than I_{HIGH} par. 224 (below current high)	[14]

Function:

The relay output can be used for giving the present status or warning. The output is activated (1-2 make) when a given condition is fulfilled.

Description of choice:

No function is selected if the adjustable frequency drive is not to react to signals.

Unit ready: there is a supply voltage on the control card of the adjustable frequency drive, and the adjustable frequency drive is ready for operation.

Enable, no warning: the adjustable frequency drive is ready for operation, but no start command has been given. No warning.

Running is active when there is a start command or the output frequency is above 0.1 Hz. Also active during ramp-down.

Running in reference, no warning: speed according to reference.

Running, no warning: a start command has been given. No warning.

Ready - line voltage within range: the adjustable frequency drive is ready for use, the control card is receiving supply voltage, and there are no active control signals on the inputs. The AC line voltage lies within the voltage limits.

★ = factory setting, () = display text, [] = value for use in communication via serial communication port

VL^T® 2800 Series

Alarm or warning: the output is activated by an alarm or warning.

Current limit: the output current is higher than the value programmed in parameter 221 Current limit I_{LIM} .

Alarm: the output is activated by an alarm.

Output frequency higher than f_{LOW} : the output frequency is higher than the value set in parameter 225

Warning: Low frequency, f_{LOW} .

Output frequency lower than f_{HIGH} : the output frequency is lower than the value set in parameter 226 *Warning: High frequency, f_{HIGH} .*

Output current higher than I_{LOW} : the output current is higher than the value set in parameter 223 *Warning: Low current, I_{LOW} .*

Output current lower than I_{HIGH} : the output current is lower than the value set in parameter 224 *Warning: High current, I_{HIGH} .*

Feedback higher than FB_{LOW} : the feedback value is higher than the value set in parameter 227 *Warning: Low feedback, FB_{LOW} .*

Feedback lower than FB_{HIGH} : the feedback value is lower than the value set in parameter 228 *Warning: High current, I_{HIGH} .*

Relay 123 is only used in connection with Profidrive.

Reversing: the relay output is activated when the direction of motor rotation is counter-clockwise. When the direction of motor rotation is clockwise, the value is 0 V DC.

Thermal warning: above the temperature limit in either the motor or the adjustable frequency drive, or from a thermistor connected to a digital input.

Local operation: the output is active when in parameter 002 *Local/remote operation, Local operation [1]* has been selected.

Out of the frequency range: the output frequency is out of the programmed frequency range in parameters 225 and 226.

Out of the current range: the motor current is out of the programmed range in parameters 223 and 224.

Out of the feedback range: the feedback signal is out of the programmed range in parameters 227 and 228.

Mechanical brake control: enables you to control an external mechanical brake (see section about control of mechanical brake in the VLT 2800 Design Guide).

327 Pulse/reference feedback

(PULSE REF/FB MAX)

Value:

150 - 67600 Hz

★ 5000 Hz

Function:

This parameter is used for setting the signal value that corresponds to the maximum value set in parameter 205 *Maximum reference, Ref_{MAX}* or to the maximum feedback value set in parameter 415 *Maximum feedback, FB_{MAX}* .

Description of choice:

Set the required pulse reference or pulse feedback to be connected to terminal 33.

328 Maximum Pulse 29

(MAX PULSE 29)

Value:

150 - 67600 Hz

★ 5000 Hz

Function:

This parameter is used for setting the signal value that corresponds to the maximum value set in parameter 205 *Maximum reference, Ref_{MAX}* or to the maximum feedback value set in parameter 415 *Maximum feedback, FB_{MAX}* .



NOTE

Only relevant for DeviceNet. See MG90BXYY for further information.

341 Digital / pulse output terminal 46

(DO 46 FUNCTION)

Value:

Unit ready (Unit ready)

[0]

Parameter [0] - [20] see parameter 323

Pulse reference (PULSE REFERENCE)

[21]

Parameter [22] - [25] see parameter 323

★ = factory setting, () = display text, [] = value for use in communication via serial communication port

VLT® 2800 Series

Pulse feedback (PULSE FEEDBACK)	[26]
Output frequency (PULSE OUTPUTFREQ)	[27]
Pulse current (PULSE CURRENT)	[28]
Pulse power (PULSE POWER)	[29]
Pulse temperature (PULSE TEMP)	[30]

Function:

The digital output can be used for giving the present status or warning. The digital output (terminal 46) gives a 24 V DC signal when a given condition is fulfilled. Terminal can also be used for frequency output. Parameter 342 sets the maximum pulse frequency.

Description of choice:

Pulse reference Ref_{MIN} - Ref_{MAX}

An output signal is obtained, which is proportional to the resulting reference value in the interval Minimum reference, Ref_{MIN} - Maximum reference, Ref_{MAX} (parameters 204/205).

Pulse feedback FB_{MIN} - FB_{MAX} .

An output signal is obtained, which is proportional to the feedback value in the interval Minimum feedback, FB_{MIN} - Maximum feedback, FB_{MAX} (parameter 414/415).

Output frequency 0- f_{MAX} .

An output signal is obtained, which is proportional to the output frequency in the interval 0 - f_{MAX} (parameter 202 *Output frequency, high limit, f_{MAX}*).

Pulse current 0 - I_{INV} .

An output signal is obtained, which is proportional to the output current in the interval 0 - I_{INV} .

Pulse power 0 - $P_{M,N}$.

An output signal is obtained, which is proportional to the present output power. Par. 342 corresponds to the value set in parameter 102 *Motor power, $P_{M,N}$* .

Pulse temperature 0 - $Temp_{MAX}$.

An output signal is obtained, which is proportional to the present heatsink temperature. 0 Hz corresponds to a heatsink temperature of less than 68 °F (20° C), and 20 mA corresponds to 212 °F (100° C).



NOTE

Output terminal 46 is not available on DeviceNet. Minimum output frequency at frequency output = 16 Hz

342 Terminal 46, max. pulse scaling (DO 46 MAX. PULS)

Value:

150 - 10000 Hz ★ 5000 Hz

Function:

This parameter is used for setting the pulse output signal's maximum frequency.

Description of choice:

Set the required frequency.

343 Precise stop function (Precise stop)

Value:

★ Precise ramp stop (normal)	[0]
Counter stop with reset (Count stop reset)	[1]
Counter stop without reset (Count stop no reset)	[2]
Speed-compensated stop (Spd cmp stop)	[3]
Speed-compensated counter stop with reset (Spd cmp cstop w. res)	[4]
Speed-compensated counter stop without re- set (Spd cmp cstop no res)	[5]

Function:

In this parameter you select which stop function is performed in response to a stop command. All six data selections contain a precise stop routine, thus ensuring a high level of repeat accuracy.

The selections are a combination of the functions described below.



NOTE

Pulse start [8] may not be used together with the precise stop function.

Description of choice:

Precise ramp stop [0] is selected to achieve high repetitive precision at the stopping point.

Counter stop. Once it has received a pulse start signal the adjustable frequency drive runs until the number of pulses programmed by the user have been received at input terminal 33. In this way an internal stop signal

★ = factory setting, () = display text, [] = value for use in communication via serial communication port

will activate the normal ramp down time (parameter 208).

The counter function is activated (starts timing) at the flank of the start signal (when it changes from stop to start).

Speed compensated stop. To stop at precisely the same point, regardless of the present speed, a stop signal received is delayed internally when the present speed is lower than the maximum speed (set in parameter 202).

Reset. Counter stop and Speed-compensated stop can be combined with or without reset.

Counter stop with reset [1]. After each precise stop the number of pulses counted during ramp down 0 Hz is reset.

Counter stop without reset [2]. The number of pulses counted during ramp down to 0 Hz is deducted from the counter value in parameter 344.

344	Counter value
(Pulse count pre.)	
Value:	
0 - 999999	★ 100,000 pulses
Function:	
In this parameter, you can select the counter value to be used in the integrated precise stop function (parameter 343).	

Description of choice:
 The factory setting is 100,000 pulses. The highest frequency (max. resolution) that can be registered at terminal 33 is 67.6 kHz.

349	Speed comp delay
(SPEED COMP DELAY)	
Value:	
0 ms - 100 ms	★ 10 ms
Function:	
In this parameter the user can set the system's delay time (Sensor, PLC, etc.). If you are running speed-compensated stop, the delay time at different frequencies has a major influence on the way in which you stop.	

Description of choice:

The factory setting is 10 ms. This means that it is assumed that the total delay from the Sensor, PLC and other hardware corresponds to this setting.



NOTE
 Only active for speed-compensated stop.

★ = factory setting, () = display text, [] = value for use in communication via serial communication port

Special functions

400 Brake function (Brake function)	
Value:	
Off (off)	[0]
Resistor brake (Resistor)	[1]
AC brake (AC Brake)	[4]
Load sharing (load sharing)	[5]

Factory setting depends on unit type.

Function:

Resistor brake [1] is selected if the adjustable frequency drive has an integral brake transistor and brake resistor is connected to terminals 81, 82. A higher intermediate circuit voltage is permitted during braking (generated operation) when a brake resistor is connected.

AC brake [4] can be selected to improve braking without using brake resistors. Please note that *AC brake* [4] is not as effective as *Resistor brake* [1].

Description of choice:

Select *Resistor brake* [1] if a brake resistor is connected.

Select *AC brake* [4] if short-term generated loads occur. See parameter 144 *Gain AC brake* to set the brake.

Select *Load sharing* [5] if this is used.



NOTE

A change of selection will not become active until the mains voltage has been disconnected and reconnected.

405 Reset function (reset mode)	
Value:	
★ Manual reset (manual reset)	[0]
Automatic reset x 1 (AUTOMATIC x 1)	[1]
Automatic reset x 3 (AUTOMATIC x 3)	[3]
Automatic reset x 10	[10]

(AUTOMATIC x 10)

Reset at power-up

(RESET AT POWER UP)

[11]

Function:

This parameter makes it possible to select whether reset and restart after a trip are to be manual or whether the adjustable frequency drive is to be reset and restarted automatically. Furthermore, it is possible to select the number of times a restart is to be attempted. The time between each attempt is set in parameter 406 *Automatic restart time*.

Description of choice:

If *Manual reset* [0] is selected, reset is to be carried out via the [STOP/RESET] key, a digital input or serial communication. If the adjustable frequency drive is to carry out an automatic reset and restart after a trip, select data value [1], [3] or [10].

If *Reset at power-up* [11] is selected, the adjustable frequency drive will carry out a reset if there has been a fault in connection with the mains failure.



The motor may start without warning.

406 Automatic restart time (autorestart time)
--

Value:

0 - 10 sec.

★ 5 sec.

Function:

This parameter allows setting of the time from tripping until the automatic reset function begins. It is assumed that automatic reset has been selected in parameter 405 *Reset function*.

Description of choice:

Set the required time.

409 Trip delay overcurrent, I _{LIM} (trip delay cur.)

Value:

0 - 60 sec. (61=OFF)

★ OFF

★ = factory setting, () = display text, [] = value for use in communication via serial communication port

Function:

When the adjustable frequency drive registers that the output current has reached the current limit I_{LIM} (parameter 221 *Current limit*) and remains there for the preset time, it is disconnected. Can be used to protect the application, like the ETR will protect the motor if selected.

Description of choice:

Select how long the adjustable frequency drive should maintain the output current at the current limit I_{LIM} before it disconnects. At OFF parameter 409 *Trip delay overcurrent*, I_{LIM} is not working, i.e. disconnection will not take place.

411 Switching frequency
(Switch freq.)
Value:

3000 - 14000 Hz (VLT 2803 - 2875) ☆ 4500 Hz
 3000 - 10000 Hz (VLT 2880 - 2882) ☆ 4500 Hz

Function:

The set value determines the switching frequency of the inverter. If the switching frequency is changed, this may help to minimise possible acoustic noise from the motor.

NOTE

The output frequency of the adjustable frequency drive can never assume a value higher than 1/10 of the switching frequency.

Description of choice:

When the motor is running, the switching frequency is adjusted in parameter 411 *Switching frequency* until the frequency has been obtained at which the motor is as low-noise as possible.

NOTE

The switching frequency is reduced automatically as a function of the load. See *Temperature-Dependent Switching Frequency under Special Conditions*.
 When *LC-filter connected* is selected in parameter 412, the minimum switching frequency is 4.5 kHz.

412 Variable switching frequency
(Var carrier freq.)
Value:

☆ Without LC-filter (WITHOUT LC-FILTER) [2]
 LC-filter connected
 (LC-filter connected) [3]

Function:

The parameter must be set to *LC-filter connected* if an LC-filter is connected between the adjustable frequency drive and the motor.

Description of choice:

The *LC-filter connected* [3] must be used if an LC-filter is connected between the adjustable frequency drive and the motor, as otherwise the adjustable frequency drive cannot protect the LC-filter.

NOTE

When the LC filter is selected the switching frequency is changed to 4.5 kHz.

413 Overmodulation function
(OVERMODULATION)
Value:

Off (off) [0]
 ☆ On (on) [1]

Function:

This parameter allows connection of the overmodulation function for the output voltage.

Description of choice:

Off [0] means that there is no overmodulation of the output voltage, which means that torque ripple on the motor shaft is avoided. This can be a good feature, e.g. on grinding machines. *On* [1] means that an output voltage can be obtained which is greater than the mains voltage (up to 5 %).

☆ = factory setting, () = display text, [] = value for use in communication via serial communication port

414 Minimum feedback, FB_{MIN}
(Min. feedback)
Value:
 -100,000.000 - par. 415 FB_{MAX} ☆ 0.000

Function:
 Parameter 414 *Minimum feedback*, FB_{MIN} and 415 *Maximum feedback*, FB_{MAX} are used to scale the display text to make it show the feedback signal in a process unit proportionally to the signal on the input.

Description of choice:
 Set the value to be shown on the display as the minimum feedback signal value on the selected feedback input (parameters 308/314 *Analog inputs*).

415 Maximum feedback, FB_{MAX}
(Max. feedback)
Value:
 FB_{MIN} - 100,000.000 ☆ 1500.000

Function:
 See description of parameter 414 *Minimum feedback*, FB_{MIN} .

Description of choice:
 Set the value to be shown on the display when the maximum feedback has been obtained on the selected feedback input (parameter 308/314 *Analog inputs*).

416 Process units
(REF/FEEDB. UNIT)
Value:

- ☆ No unit (No unit) [0]
- % (%) [1]
- ppm (ppm) [2]
- rpm (rpm) [3]
- bar (bar) [4]
- Cycles/min. (CYCLE/MIN.) [5]
- Pulses/sec. (PULSE/SEC.) [6]
- Units/sec. (UNITS/SEC.) [7]
- Units/min. (UNITS/MIN.) [8]
- Units/h (Units/h) [9]
- °C (°C) [10]

- Pa (pa) [11]
- l/s (l/s) [12]
- m³/s (m³/s) [13]
- l/min. (l/min.) [14]
- m³/min. (m³/min) [15]
- l/h (l/h) [16]
- m³/h (m³/h) [17]
- kg/sec. (kg/sec.) [18]
- kg/min. (kg/min.) [19]
- kg/hour (kg/h) [20]
- tons/min. (T/min) [21]
- tons/hour (T/h) [22]
- Meters (m) [23]
- Nm (nm) [24]
- m/sec. (m/sec.) [25]
- m/min. (m/min) [26]
- °F (°F) [27]
- ln wg (in wg) [28]
- gal/sec. (gal/sec.) [29]
- ft³/sec. (ft³/sec.) [30]
- gal/min. (gal/min) [31]
- ft³/min. (ft³/min) [32]
- gal/h (gal/h) [33]
- ft³/h (ft³/h) [34]
- lb/sec. (lb/sec.) [35]
- lb/min. (lb/min.) [36]
- lb/hour (lb/h) [37]
- lb ft (lb ft) [38]
- ft/s (ft/s) [39]
- ft/min. (ft/min.) [40]
- psi (psi) [41]

Function:
 Select which of the different units are to be shown on the display. The unit is read out if an LCP control unit can be connected, and if *Reference [unit]* [2] or *Feedback [unit]* [3] has been selected in one of parameters 009-012 *Display readout*, and in display mode. The unit is used in *Closed-loop* also as a unit for minimum/maximum reference and minimum/maximum feedback.

☆ = factory setting, () = display text, [] = value for use in communication via serial communication port

VLT® 2800 Series

Description of choice:

Select the required unit for the reference/feedback signal.



NOTE

Parameters 417-421 are only used, if in parameter 100 *Configuration* the selection made is *Speed regulation, closed loop* [1].

417 Speed PID proportional gain

(SPEED PROP GAIN)

Value:

0.000 (OFF) - 1.000 ☆ 0.010

Function:

Proportional gain indicates how many times the fault (deviation between the feedback signal and the set-point) is to be amplified.

Description of choice:

Quick regulation is obtained at high amplification, but if the amplification is too high, the process may become unstable in the case of overshooting.

418 Speed PID integral time

(SPEED int. time)

Value:

20.00 - 999.99 ms (1000 = OFF) ☆ 100 ms

Function:

The integral time determines how long the PID regulator takes to correct the error. The greater the error, the quicker the integrator frequency contribution will increase. The integral time is the time the integrator needs to achieve the same change as the proportional amplification.

Description of choice:

Quick regulation is obtained through a short integral time. However, if this time is too short, it can make the process unstable. If the integral time is long, major deviations from the required reference may occur, since the process regulator will take long to regulate if an error has occurred.

419 Speed PID differential time

(SPEED diff. time)

Value:

0.00 (OFF) - 200.00 ms ☆ 20.00 ms

Function:

The differentiator does not react to a constant error. It only makes a contribution when the error changes. The quicker the error changes, the stronger the gain from the differentiator will be. The contribution is proportional to the speed at which errors change.

Description of choice:

Quick control is obtained by a long differential time. However, if this time is too long, it can make the process unstable. When the differential time is 0 ms, the D-function is not active.

420 Speed PID D- gain limit

(SPEED D-GAIN LIM)

Value:

5.0 - 50.0 ☆ 5.0

Function:

It is possible to set a limit for the gain provided by the differentiator. Since the D-gain increases at higher frequencies, limiting the gain may be useful. This enables obtaining a pure D-gain at low frequencies and a constant D-gain at higher frequencies.

Description of choice:

Select the required gain limit.

421 Speed PID lowpass filter time

(speed filt. time)

Value:

20 - 500 ms ☆ 100 ms

Function:

Noise in the feedback signal is dampened by a first order lowpass filter to reduce the noise's impact on the regulation. This might be an advantage, e.g. if there is a great amount of noise on the signal. See drawing.

☆ = factory setting, () = display text, [] = value for use in communication via serial communication port

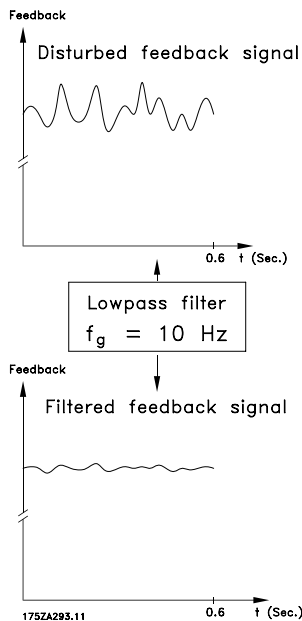

Description of choice:

If a time constant (t) of 100 ms is programmed, the cut-off frequency for the lowpass filter will be $1/0.1 = 10$ RAD/sec., corresponding to $(10 / 2 \times \pi) = 1.6$ Hz. The PID regulator will then only regulate a feedback signal that varies with a frequency of less than 1.6 Hz. If the feedback signal varies by a higher frequency than 1.6 Hz, it will be dampened by the lowpass filter.

423 U1 voltage (U1 voltage)

Value:

0.0 - 999.0 V ★ par. 103

Function:

Parameters 423-428 are used when in parameter 101 *Torque characteristic* a selection has been made of *Special motor characteristic* [8]. It is possible to determine a U/f characteristic on the basis of four definable voltages and three frequencies. The voltage at 0 Hz is set in parameter 133 *Start voltage*.

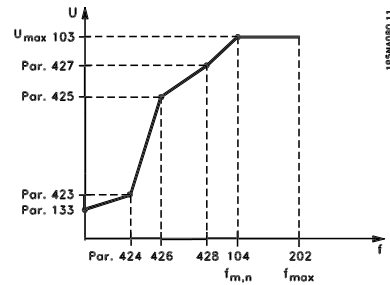

Description of choice:

Set the output voltage (U1) that is to match the first output frequency (F1), parameter 424 *F1 frequency*.

424 F1 frequency (F1 frequency)

Value:

0.0 - par. 426 *F2 frequency* ★ Par. 104 *Motor frequency*

Function:

See parameter 423 *U1 voltage*.

Description of choice:

Set the output frequency (F1) that is to match the first output voltage (U1), parameter 423 *U1 voltage*.

425 U2 voltage (U2 voltage)

Value:

0.0 - 999.0 V ★ par. 103

Function:

See parameter 423 *U1 voltage*.

Description of choice:

Set the output voltage (U2) that is to match the second output frequency (F2), parameter 426 *F2 frequency*.

426 F2 frequency (F2 frequency)

Value:

Par. 424 *F1 frequency* - par. 428 ★ Par. 104 *Motor frequency*

★ = factory setting, () = display text, [] = value for use in communication via serial communication port

Function:

See parameter 423 *U1 voltage*.

Description of choice:

Set the output frequency (F2) that is to match the second output voltage (U2), parameter 425 *U2 voltage*.

**427 U3 voltage
(U3 voltage)**
Value:

0.0-999.0 V ★ par. 103

Function:

See parameter 423 *U1 voltage*.

Description of choice:

Set the output voltage (U3) that is to match the third output frequency (F3), parameter 428 *F3 frequency*.

**428 F3 frequency
(F3 frequency)**
Value:

Par. 426 *F2 frequency* - 1000 ★ Par. 104 *Motor frequency*
Hz

Function:

See parameter 423 *U1 voltage*.

Description of choice:

Set the output frequency (F3) that is to match the third output voltage (U3), parameter 427 *U3 voltage*.

NOTE

Parameters 437-444 are only used if in parameter 100 *Configuration* a selection has been made of *Process regulation, closed loop*. [3].

**437 Process PID normal/inverse control
(proc no/inv ctrl)**
Value:

★ Normal (normal) [0]
Inverse (inverse) [1]

Function:

It is possible to choose whether the process regulator is to increase/reduce the output frequency if there is a deviation between the reference/setpoint and the actual process mode.

Description of choice:

If the adjustable frequency drive is to reduce the output frequency in case the feedback signal increases, select *Normal* [0]. If the adjustable frequency drive is to increase the output frequency in case the feedback signal increases, select *Inverse* [1].

**438 Proces PID anti windup
(proc anti windup)**
Value:

Not active (DISABLE) [0]
★ Active (ENABLE) [1]

Function:

It is possible to select whether the process regulator is to continue regulating on a deviation even if it is not possible to increase/reduce the output frequency.

Description of choice:

The factory setting is *Enable* [1], which means that the integration link is initialised in relation to the actual output frequency if either the current limit, the voltage limit or the max./min. frequency has been reached. The process regulator will not engage again until either the error is zero or its sign has changed. Select *Disable* [0] if the integrator is to continue integrating on the deviation, even if it is not possible to remove the fault by such control.

NOTE

If *Disable* [0] is selected, it will mean that when the deviation changes its sign, the integrator will first have to integrate down from the level obtained as a result of the former error, before any change in output frequency occurs.

★ = factory setting, () = display text, [] = value for use in communication via serial communication port

**439 Process PID start frequency
(PROC START VALUE)**

Value:

f_{MIN} - f_{MAX} (parameter) ★ Par. 201 Output frequency, low limit, f_{MIN} 201/202)

Function:

When the start signal comes, the adjustable frequency drive will react in the form of *Open loop* and will not change to *Closed loop* until the programmed start frequency is reached. This makes it possible to set a frequency that corresponds to the speed at which the process normally runs, which will enable the required process conditions to be reached sooner.

Description of choice:

Set the required start frequency.



NOTE

If the adjustable frequency drive is running a the current limit before the required start frequency is obtained, the process regulator will not be activated. For the regulator to be activated anyway, the start frequency must be lower to the required output frequency. This can be done during operation.

**440 Proces PID proportioanl gain
(PROC. PROP. GAIN)**

Value:

0.0 - 10.00 ★ 0.01

Function:

The proportional gain indicates the number of times the deviation between the setpoint and the feedback signal is to be applied.

Description of choice:

Quick regulation is obtained by a high gain, but if the gain is too high, the process may become unstable due to overshoot.

**441 Process PID integration time
(PROC. INTEGR. T.)**

Value:

0.01 - 9999.99 (OFF) ★ OFF

Function:

The integrator provides an increasing gain at a constant error between the reference/setpoint and the feedback signal. The greater the error, the quicker the integrator frequency contribution will increase. The integral time is the time needed by the integrator to make the same change as the proportional gain.

Description of choice:

Quick regulation is obtained at a short integral time. However, this time may become too short, which can make the process unstable due to overshwing. If the integral time is long, major deviations from the required setpoint may occur, since the process regulator will take a long time to regulate in relation to a given error.

**442 Process PID differentiation time
(PROC. DIFF. time)**

Value:

0.00 (OFF) - 10.00 sec. ★ 0.00 sec.

Function:

The differentiator does not react to a constant error. It only makes a gain when an error changes. The quicker the deviation changes, the stronger the gain from the differentiator. The gain is proportional to the speed at which the deviation changes.

Description of choice:

Quick regulation is obtained with a long differentiation time. However, this time may become too long, which can make the process unstable due to overshwing.

**443 Process PID diff. gain limit
(PROC. DIFF.GAIN)**

Value:

5.0 - 50.0 ★ 5.0

★ = factory setting, () = display text, [] = value for use in communication via serial communication port

Function:

It is possible to set a limit for the differentiator gain. The differentiator gain will increase if there are fast changes, which is why it can be beneficial to limit this gain. Thereby a pure differentiator gain is obtained at slow changes and a constant differentiator gain where quick changes to the deviation occur.

Description of choice:

Select a differentiator gain limit as required.

**444 Process PID lowpass filter time
(proc filter time)**
Value:

0.02 - 10.00 ★ 0.02

Function:

Noise in the feedback signal is dampened by a first order lowpass filter to reduce the noise's impact on the process regulation. This can be an advantage e.g. if there is a lot of noise on the signal.

Description of choice:

Select the required time constant (t). If a time constant (t) of 0.1 s is programmed, the cut-off frequency for the lowpass filter will be $1/0.1 = 10$ RAD/sec., corresponding to $(10 / 2 \times \pi) = 1.6$ Hz. The process regulator will thus only regulate a feedback signal that varies by a frequency lower than 1.6 Hz. If the feedback signal varies by a higher frequency than 1.6 Hz, it will be dampened by the lowpass filter.

**445 Flying start
(flyingstart)**
Value:

- ★ Off (DISABLE) [0]
- OK - same direction
(OK-same direction) [1]
- OK - both directions
(OK-both directions) [2]
- DC brake and start
(DC-BRAKE BEF. START) [3]

Function:

This function makes it possible to 'catch' a rotating motor shaft, which is no longer controlled by the adjustable frequency drive, e.g. because of a mains drop-out. The function is activated each time a start command is enabled. For the adjustable frequency drive to be able to 'catch' the rotating motor shaft, the motor speed must be lower than the frequency that corresponds to the frequency in parameter 202 *Output frequency, high limit, f_{MAX}*.

Description of choice:

Select *Disable* [0] if this function is not required.

Select *OK - same direction* [1] if the motor shaft is only able to rotate in the same direction when cutting in. *OK - same direction* [1] should be selected if in parameter 200 *Output frequency range* a selection has been of *Clockwise only*.

Select *OK - both directions* [2] if the motor is able to rotate in both directions when cutting in.

Select *DC brake and start* [3] if the adjustable frequency drive is to be able to brake the motor using the DC brake first, followed by start. It is assumed that parameters 126-127/132 *DC brake* are enabled. In the case of higher 'Windmilling' (rotating motor) effects, the adjustable frequency drive is not able to 'catch' a rotating motor without selecting *DC brake and start*.

Limitations:

- Too low inertia will lead to load acceleration, which can be dangerous or prevent correct catching of a rotating motor. Use the DC brake instead.
- If the load is driven, e.g. by 'Windmilling' (rotating motor) effects, the unit may cut out because of overvoltage.
- Flying start does not work at lower values than 250 rpm.

**451 Speed PID feedforward factor
(feedforward fact)**
Value:

0 - 500 % ★ 100 %

★ = factory setting, () = display text, [] = value for use in communication via serial communication port

Function:

This parameter is only active if in parameter 100 *Configuration* the selection made is *Speed regulation, closed loop*. The FF function sends a larger or smaller part of the reference signal outside the PID controller in such a way that the PID controller only has an influence on part of the control signal. Any change to the set point will thus have a direct effect on the motor speed. The FF factor provides high dynamism when changing the set point and less overshoot.

Description of choice:

The required % value can be selected in the interval $f_{MIN} - f_{MAX}$. Values over 100 % are used if the set point variations are only small.

452 Controller range
(pid contr. range)
Value:

 0 - 200 % ★ 10 %
Function:

This parameter is only active if *Speed regulation, closed-loop* is made in parameter 100 *Configuration*. The controller range (bandwidth) limits the output from the PID controller as a % of motor frequency $f_{M,N}$.

Description of choice:

The required % value can be selected for motor frequency $f_{M,N}$. If the controller range is reduced, the speed variations will be less during initial tuning.

455 Frequency range monitor
(MON. FREQ. RANGE)
Value:

Disable	[0]
★ Enable	[1]

Function:

This parameter is used if warning 33 *Out of frequency range* must be turned off in the display in process control closed-loop. This parameter does not affect the extended status word.

Description of choice:

Select *Enable* [1] to enable the readout in the display if warning 33 *Out of frequency range* occurs. Select *Disable* [0] to disable the readout in the display if warning 33 *Out of frequency range* occurs.

456 Brake Voltage Reduce
(BRAKE VOL REDUCE)
Value:

0 - 25 V if 200 V device	★ 0
0 - 50 V if 400 V device	★ 0

Function:

The user sets the voltage by which the level for resistor braking is reduced. It is only active when resistor in parameter 400 is selected.

Description of choice:

The greater the reduction value, the faster the reaction to a generator overload. Should only be used if there are problems with overvoltage in the intermediate circuit.

457 Phase loss function
(PHASE LOSS FUNCT)
Value:

★ Trip (TRIP)	[0]
Autoderate & warning (AUTODERATE & WARNING)	[1]
Warning (WARNING)	[2]

Function:

Select the function which is to be activated if the mains imbalance becomes too high or if a phase is missing.

Description of choice:

At *Trip* [0] the adjustable frequency drive will stop the motor within a few seconds (depending on drive size). If *Autoderate & warning* [1] is selected, the drive will export a warning and reduce the output current to 50 % of $I_{VLT,N}$ to maintain operation. At *Warning* [2] only a warning will be exported when a mains failure occurs, but in severe cases, other extreme conditions might result in a trip.

★ = factory setting, () = display text, [] = value for use in communication via serial communication port



NOTE

If *Warning* has been selected, the life expectancy of the drive will be reduced when the mains failure persists.

**461 Feedback conversion
(FEEDBACK CONV.)**

Value:

- ★ Linear (LINEAR) [0]
- Square root (SQUARE ROOT) [1]

Function:

In this parameter, a function is selected which converts a connected feedback signal from the process to a feedback value that equals the square root of the connected signal. For example, this is used when flow (volume) regulation is required on the basis of pressure as feedback signal (flow = constant x $\sqrt{\text{pressure}}$). This conversion makes it possible to set the reference in such a way that there is a linear connection between the reference and the flow required.

Description of choice:

If *Linear* [0] is selected, the feedback signal and the feedback value will be proportional. If *Square root* [1] is selected, the adjustable frequency drive translates the feedback signal to a squared feedback value.

■ Enhanced Sleep Mode

The enhanced sleep mode has been developed to work under all conditions and to overcome problems when using pumps with flat pump curves, or when suction pressure varies. Enhanced sleep mode provides excellent control for shutting down the pump at low-flow, thus saving energy.

If operating with constant pressure control in the SYSTEM, for instance a drop in the suction pressure will lead to an increase in frequency to maintain pressure. Consequently there is a situation, where the frequency will vary independent of the flow. This can lead to inappropriate activation of sleep mode or wake-up of the adjustable frequency drive.

Flat pump curves leads to a situation where there will be little or no change in frequency in response to flow variation. Consequently, the adjustable frequency drive might not reach the sleep frequency when setting it at a low value.

Enhanced sleep mode is based on power/frequency monitoring and works in closed loop only. Stop due to the enhanced sleep mode function is initiated under the following conditions:

- Power consumption is below the no/low flow power curve and stays there for a certain time (parameter 462 *Enhanced sleep mode timer*) **or**
- The pressure feedback is above the reference when running at minimum speed and stays there for a certain time (parameter 462 *Enhanced sleep mode timer*).

If the feedback pressure falls below the wakeup pressure (Parameter 464 *Wakeup pressure*), the adjustable frequency drive restarts the motor.

■ Dry Run Detection

For most pumps, especially submersible bore-hole pumps, it must be assured that the pump is stopped in case of dry run. This is assured by the Dry run detection feature.

How Does It Work?

Dry run detection is based on power/frequency monitoring and works in both closed and open loop.

Stop (trip) due to dry run is initiated under following conditions:

Closed loop:

- The adjustable frequency drive is running at maximum frequency (parameter 202 *Output frequency high limit, f_{MAX}*) **and**
- Feedback is below minimum reference (parameter 204 *Minimum reference, Ref_{MIN}*) **and**
- Power consumption is below the no/low flow power curve for a certain time (parameter 470 *Dry run time out*)

Open loop:

- Whenever the power consumption is below the no/low flow power curve for a certain time (parameter 470 *Dry run time out*) the adjustable frequency drive will trip.

The adjustable frequency drive can be set up for either manual or automatic restart after stop (parameters 405 *Reset function* and 406 *Automatic restart time*).

- Enhanced Sleep Mode and Dry Run Detection can be enabled and disabled independently. This is done in parameter 462 *Enhanced sleep mode timer* and parameter 470 *Dry run timeout*.

Centrifugal pumps with radial impellers show a clear one-to-one relation between power consumption and flow, which is utilized to detect a no or low flow situation.

It is only necessary to enter two sets of values for power and frequency (min and max) at no or low flow. The adjustable frequency drive then automatically calculates all data in-between those two sets of values and generates the no/low flow power curve.

If the power consumption falls below the power curve, the adjustable frequency drive enters Sleep-mode or trips due to dry run, depending on the configuration.

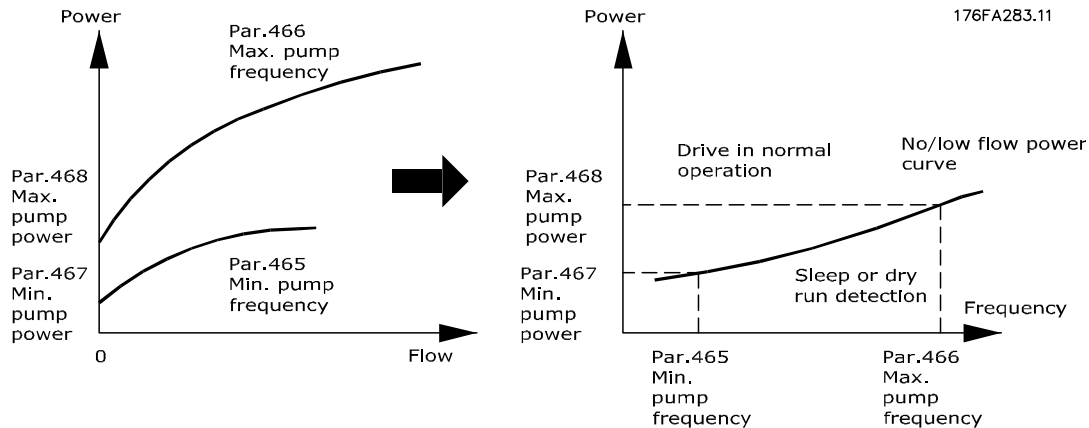

- Dry run protection. Shuts down at no or low-flow and protects the motor and pump from overheating.
- Improved energy savings with enhanced sleep mode.
- Minimized risk of bacterial growth in drinking water because of insufficient motor cooling.
- Easy commissioning.

Only centrifugal pumps with radial impellers show a clear one-to-one relationship between flow and power. Consequently, proper functionality of the Enhanced Sleep Mode and Dry Run Detection is only given for this type of pump.

462 Enhanced Sleep Mode Timer (ESL timer)

Value:
Value 0 – 9999 sec. ★ 0 = OFF

Function:
The timer prevents cycling between Sleep mode and normal operation. If for instance the power consumption falls below the no/low flow power curve the adjustable frequency drive will change mode when the timer expires.

Description of choice:
In case of cycling, set the timer to an appropriate value that limits the number of cycles.
The value 0 disables Enhanced sleep mode.
Note: In parameter 463 *Boost set point* it is possible to set up the adjustable frequency drive to provide a pressure boost before the pump is stopped.

463 Boost setpoint (BOOST SETPOINT)

Value:
1 - 200 % ★ 100 % of setpoint

Function:
This function can only be used if *Closed loop* has been selected in parameter 100.
In systems with constant pressure regulation, it is advantageous to increase the pressure in the system before the adjustable frequency drive stops the motor. This extends the time during which the adjustable frequency drive stops the motor and helps to avoid frequent starting and stopping of the motor, e.g. in the case of leaks in the water supply system.

There is a fixed boost time-out on 30 sec. in case the boost setpoint cannot be reached.

Description of choice:
Set the required *Boost setpoint* as a percentage of the resulting reference under normal operation. 100% corresponds to the reference without boost (supplement).

★ = factory setting, () = display text, [] = value for use in communication via serial communication port

464	Wakeup Pressure
(Wakeup Pressure)	
Value:	
Par. 204 Ref _{MIN} – par. 215 - 218 Setpoint ☆ 0	
Function:	
When in Sleep mode the adjustable frequency drive will wake up when the pressure is below the Wakeup pressure for the time set in parameter 462 <i>Enhanced sleep mode timer</i> .	
Description of choice:	
Set an appropriate value for the system. The unit is set in parameter 416.	

465	Minimum pump frequency
(Pump min. freq.)	
Value:	
Value par. 201 f _{MIN} – par. 202 f _{MAX} (Hz) ☆ 20	
Function:	
This parameter is linked to parameter 467 <i>Minimum Power</i> and is used for no/low-flow power curve.	
Description of choice:	
Enter a value equal or close to the desired minimum frequency set in parameter 201 <i>Output frequency low limit, f_{MIN}</i> . Please note that the extension of the no/low-flow power curve is limited by parameters 201 and 202, and not by parameters 465 and 466.	

466	Maximum Pump Frequency
(Pump max. freq)	
Value:	
Value par. 201 f _{MIN} - par. 202 f _{MAX} (Hz) ☆ 50	
Function:	
This parameter is linked to parameter 468 <i>Maximum pump power</i> and is used for the no/low-flow power curve.	
Description of choice:	
Enter a value equal or close to the desired maximum frequency set in parameter 202 <i>Output frequency high limit, f_{MAX}</i> .	

467	Minimum Pump Power
(Min. pump power)	
Value:	
0–500.000 W ☆ 0	
Function:	
The associated power consumption at the frequency entered in parameter 465 <i>Minimum pump frequency</i> .	
Description of choice:	
Enter the no/low-flow power reading at minimum pump frequency entered in parameter 465.	
Depending on pump size or curve, select W or kW in par. 009 index [32] and [8] for fine tuning.	

468	Maximum Pump Power
(Max. pump power)	
Value:	
0–500.000 W ☆ 0	
Function:	
The associated power consumption at the frequency entered in parameter 466 <i>Minimum pump frequency</i> .	
Description of choice:	
Enter the no/low-flow power reading at maximum pump frequency entered in parameter 466.	
Depending on pump size or curve, select W or kW in par. 009 index [32] and [8] for fine tuning.	

469	No Flow Power Compensation
(NF power comp)	
Value:	
0.01 - 2 ☆ 1.2	
Function:	
This function is used for an off-set of the no/low-flow power curve, which can be used as a safety factor or for fine tuning the system.	
Description of choice:	
Description The factor is multiplied to the power values. E.g., 1.2 will increase the power value with 1.2 over the whole frequency range.	

Programming

☆ = factory setting, () = display text, [] = value for use in communication via serial communication port

470 Dry Run Time Out

(DRY RUN TIME OUT)

Value:

5-30 sec. ★ 31 = OFF

Function:

If the power is below the no/low flow power curve, running at max speed for the time set in this parameter, the adjustable frequency drive will trip on Alarm 75: Dry run. In open loop operation the maximum speed does not necessarily need to be reached before tripping.

Description of choice:

Set the value to obtain the desired delay before tripping. Manual or automatic restart can be programmed in parameter 405 *Reset function* and 406 *automatic restart time*.

The value 30 disables Dry run detection.

471 Dry Run Interlock Timer

(Dry run int time)

Value:

0.5-60 min. ★ 30 min.

Function:

This timer determines when a trip due to dry run can be automatically reset. When the timer expires, the automatic reset of the trip can automatically restart the adjustable frequency drive again.

Description of choice:

Parameter 406 *Automatic restart time* still determines how frequent an attempt to reset a trip will be performed. If for instance parameter 406 *Automatic restart time* is set to 10 sec. and parameter 405 *Reset function* is set to Automatic Reset x10 the adjustable frequency drive will attempt to reset the trip 10 times within 100 seconds. If parameter 471 is set to 30 min. the adjustable frequency drive will consequently not be able to perform automatic reset of dry run trip and will need a manual reset.

484 Initial ramp

(INITIAL RAMP)

Value:

OFF/000.1s - 360.0 s ★ OFF

Function:

Allows the motor/equipment to be brought up to minimum speed (frequency) at a rate different than the normal ramp-up rate (param. 207).

Description of choice:

For example, vertical pumps and other equipment often have a requirement to not operate below a minimum speed any longer than necessary. Damage and excessive wear can occur when operating below minimum speed (frequency) for too long. The initial ramp is used to quickly accelerate the motor/equipment to minimum speed at which point, the normal ramp-up rate (parameter 207) is made active. The range of adjustment of the initial ramp is from 000.1 second to 360.0 seconds; it can be adjusted in 0.1 second increments. OFF is displayed in this parameter if it is set to 000.0, and the initial ramp is not active and the normal ramp-up is active.

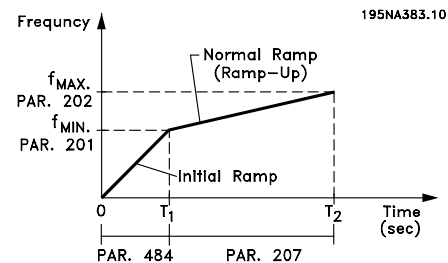

■ Fill Mode

Fill Mode eliminates the occurrence of water hammer associated with the rapid exhausting of air from piping systems (such as Irrigation systems).

The adjustable frequency drive, set for Closed Loop operation uses an adjustable Fill Rate, a "Filled Pressure" setpoint, an operating pressure setpoint, and a pressure feedback.

Fill Mode is available when:

- The VLT 2800 drive is in **Closed Loop** mode (parameter 100).
- Parameter 485 is **not 0**
- Parameter 437 is set to **NORMAL**

★ = factory setting, () = display text, [] = value for use in communication via serial communication port

VLT® 2800 Series

After a start command, Fill Mode operation begins when the adjustable frequency drive reaches minimum frequency - set in parameter 201.

The "Filled" Setpoint - parameter 486- is actually a setpoint limit. When minimum speed is reached, the pressure feedback is looked at, and the adjustable frequency drive begins to ramp to the "Filled" pressure setpoint at the rate established by Fill Rate parameter 485.

The Fill Rate - parameter 485- is dimensioned in Units/Second. The Units will be the units selected in parameter 416.

When the pressure feedback equals the "Filled" Setpoint, the control transitions to the operating setpoint (Setpoint 1-4, param. 215-218) and continues operation in standard (normal) "closed loop" mode.

The value to use for the "Filled" Setpoint parameter 486, can be determined by:

1. Use the DISPLAY MODE key on the LCP to display **FEEDBACK 1**.
IMPORTANT! Be sure that you have selected the UNITS in parameter 416 before this step.
2. Operate the VLT 2800 in **HAND** mode and slowly advance the speed to fill the pipe while being careful not to create a water hammer.
3. An observer at the end of the pipe must be able to report when the pipe is filled.
4. At that instant, stop the motor, and observe the value of pressure feedback (have the LCP display set to observe the feedback before starting).
5. The value of feedback in step 4) is the value to use in parameter 486 - "Filled" Setpoint.

The value to set in parameter 485- Fill Rate can be supplied by the system engineer from proper calculation or from experience, or it can be determined experimentally by performing numerous fill mode sequences and either increasing or decreasing the value of this parameter to obtain the fastest fill without causing a water hammer.

The **Fill Mode** is also beneficial when bringing the motor to a stop as it prevents sudden changes in pressure and flow which could also cause a water hammer.

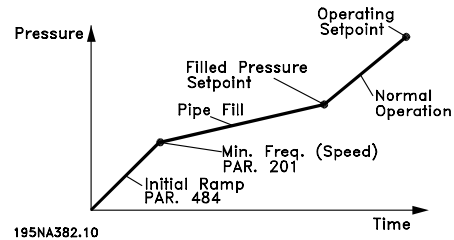

485 Fill Rate

(FILL RATE)

Value:

OFF/000000.001 - 999999.999 (units/s) - ☆ OFF

Function:

Establishes the rate at which the pipe is filled.

Description of choice:

The dimension of this parameter is units/second. The units will be the value selected in parameter 416. For example, the units could be bar, MPa, PSI, etc. If bar is the selected unit in parameter 416, then the number set in this parameter (485) would be dimensioned as bar/second. Changes to this parameter can be made in steps of .001 units.

486 Filled Setpoint

(FILLED SETPOINT)

Value:

Param. 414 - Param. 205 - ☆ Param. 414

Function:

The value set in this parameter corresponds to the pressure that exists at the pressure sensor when the pipe is filled.

Description of choice:

The units of this parameter correspond to the units selected in Parameter 416. The minimum value of this parameter is $F_{b_{min}}$ (param. 414). The maximum value for this parameter is Ref_{max} (param. 205). The setpoint can be changed in .01 steps.

☆ = factory setting, () = display text, [] = value for use in communication via serial communication port

Serial communication

500 Address (BUS ADDRESS)

Value:

Parameter 500 Protocol = FC protokol [0]	0 - 247	★ 1
Parameter 500 Protocol = Metasys N2 [1]	1 - 255	★ 1
Parameter 500 Protocol = MODBUS RTU [3]	1 - 247	★ 1

Function:

This parameter allows the allocation of an address to each variable frequency drive in a serial communication network.

Description of choice:

The individual variable frequency drive must be allocated a unique address.
If the number of units connected (variable frequency drives + master) is higher than 31, a repeater must be used.
Parameter 500 *Address* cannot be selected via the serial communication, but must be preset via the control unit.

501 Baudrate (BAUDRATE)

Value:

300 Baud (300 BAUD)	[0]
600 Baud (600 BAUD)	[1]
1200 Baud (1200 BAUD)	[2]
2400 Baud (2400 BAUD)	[3]
4800 Baud (4800 BAUD)	[4]
★ 9600 Baud (9600 BAUD)	[5]

Function:

This parameter is for programming the speed at which data is transmitted via the serial port. Baud rate is defined as the number of bits transmitted per second.

Description of choice:

The variable frequency drive's transmission speed must be set at a value corresponding to the transmission speed of the master.

Parameter 501 *Baudrate* cannot be selected via the serial port, but must be preset via the operating unit.

502 Coasting Stop (COASTING SELECT)

Value:

Digital input (DIGITAL INPUT)	[0]
Serial port (SERIAL PORT)	[1]
Logic and (LOGIC AND)	[2]
★ Logic or (LOGIC OR)	[3]

Function:

Parameters 502-508 allow a choice between controlling the adjustable frequency drive via the digital inputs and/or via the serial port.
If *Serial port* [1] is selected, the relevant command can only be activated if a command is given via the serial port.
In the case of *Logic and* [2] the function must also be activated via a digital input.

Description of choice:

The table below shows when the motor is running and when it is coasting, when each of the following is selected: *Digital input* [0], *Serial port* [1], *Logic and* [2] or *Logic or* [3].



NOTE

Note that *Coasting stop* and Bit 03 in the control word are active at logic '0'.

Digital input [0]

Dig. input	Ser. port	Function
0	0	Coasting
0	1	Coasting
1	0	Motor running
1	1	Motor running

Serial port [1]

Dig. input	Ser. port	Function
0	0	Coasting
0	1	Motor running
1	0	Coasting
1	1	Motor running

Logic and [2]

Dig. input	Ser. port	Function
0	0	Coasting
0	1	Motor running
1	0	Motor running
1	1	Motor running

★ = factory setting, () = display text, [] = value for use in communication via serial communication port

VLT® 2800 Series

Logic or [3]		
Dig. input	Ser. port	Function
0	0	Coasting
0	1	Coasting
1	0	Coasting
1	1	Motor running

503 Quick-stop

(Q STOP SELECT)

Value:

Digital input (DIGITAL INPUT)	[0]
Serial port (SERIAL PORT)	[1]
Logic and (LOGIC AND)	[2]
★ Logic or (LOGIC OR)	[3]

Function:

See function description for parameter 502 *Coasting stop*.

Description of choice:

The table below shows when the motor is running and when it is in Quick stop mode, when each of the following is selected: *Digital input* [0], *Serial port* [1], *Logic and* [2] or *Logic or* [3].



NOTE

Note that *Quick stop inverse* and Bit 04 in the control word are active at logic '0'.

Digital input [0]		
Dig. input	Serial port	Function
0	0	Quick stop
0	1	Quick stop
1	0	Motor running
1	1	Motor running

Serial port [1]		
Dig. input	Serial port	Function
0	0	Quick stop
0	1	Motor running
1	0	Quick stop
1	1	Motor running

Logic and [2]		
Dig. input	Serial port	Function
0	0	Quick stop
0	1	Motor running
1	0	Motor running
1	1	Motor running

Logic or [3]		
Dig. input	Serial port	Function
0	0	Quick stop
0	1	Quick stop
1	0	Quick stop
1	1	Motor running

504 DC brake

(DC BRAKE SELECT)

Value:

Digital input (DIGITAL INPUT)	[0]
Serial port (SERIAL PORT)	[1]
Logic and (LOGIC AND)	[2]
★ Logic or (LOGIC OR)	[3]

Function:

See function description for parameter 502 *Coasting stop*.

Description of choice:

The table below shows when the motor is running and the DC braking when each of the following is selected *Digital input* [0], *Serial port* [1], *Logic and* [2] or *Logic or* [3].



NOTE

Note that *DC braking inverse* and Bit 02 in the control word are active at logic '0'.

Digital input [0]		
Dig. input	Ser. port	Function
0	0	DC braking
0	1	DC braking
1	0	Motor running
1	1	Motor running

Serial port [1]		
Dig. input	Ser. port	Function
0	0	DC braking
0	1	Motor running
1	0	DC braking
1	1	Motor running

★ = factory setting, () = display text, [] = value for use in communication via serial communication port

VLT® 2800 Series

Logic and [2]		
Dig. input	Ser. port	Function
0	0	DC braking
0	1	Motor running
1	0	Motor running
1	1	Motor running

Logic or [3]		
Dig. input	Ser. port	Function
0	0	DC braking
0	1	DC braking
1	0	DC braking
1	1	Motor running

Logic and [2]		
Dig. input	Ser. port	Function
0	0	Stop
0	1	Stop
1	0	Stop
1	1	Start

Logic or [3]		
Dig. input	Ser. port	Function
0	0	Stop
0	1	Start
1	0	Start
1	1	Start

505 Start	
(START SELECT)	
Value:	
Digital input (DIGITAL INPUT)	[0]
Serial port (SERIAL PORT)	[1]
Logic and (LOGIC AND)	[2]
★ Logic or (LOGIC OR)	[3]

Function:
See function description for parameter 502 *Coasting stop*.

Description of choice:
The table below shows when the motor has stopped and when the variable frequency drive has a start command when each of the following is selected: *Digital input* [0], *Serial port* [1], *Logic and* [2] or *Logic or* [3].

Digital input [0]		
Dig. input	Ser. port	Function
0	0	Stop
0	1	Stop
1	0	Start
1	1	Start

Serial port [1]		
Dig. input	Ser. port	Function
0	0	Stop
0	1	Start
1	0	Stop
1	1	Start

506 Reverse	
(REVERSE SELECT)	
Value:	
Digital input (DIGITAL INPUT)	[0]
Serial port (SERIAL PORT)	[1]
Logic and (LOGIC AND)	[2]
★ Logic or (LOGIC OR)	[3]

Function:
See function description for parameter 502 *Coasting stop*.

Description of choice:
The table below shows when the motor is running clockwise and counter-clockwise when each of the following is selected: *Digital input* [0], *Serial port* [1], *Logic and* [2] or *Logic or* [3].

Digital input [0]		
Dig. input	Ser. port	Function
0	0	Clockwise
0	1	Clockwise
1	0	Counter-clockwise
1	1	Counter-clockwise

Serial port [1]		
Dig. input	Ser. port	Function
0	0	Clockwise
0	1	Counter-clockwise
1	0	Clockwise
1	1	Counter-clockwise

★ = factory setting, () = display text, [] = value for use in communication via serial communication port

VLT® 2800 Series

Logic and [2]		
Dig. input	Ser. port	Function
0	0	Clockwise
0	1	Clockwise
1	0	Clockwise
1	1	Counter-clockwise

Logic or [3]		
Dig. input	Ser. port	Function
0	0	Clockwise
0	1	Counter-clockwise
1	0	Counter-clockwise
1	1	Counter-clockwise

507 Selection of Setup (SETUP SELECT)

Value:

Digital input (DIGITAL INPUT)	[0]
Serial communication (SERIAL PORT)	[1]
Logic and (LOGIC AND)	[2]
★ Logic or (LOGIC OR)	[3]

Function:

See function description of parameter 502 *Coasting stop*.

Description of choice:

The table below shows which Setup (parameter 004 *Active Setup*) is selected for each of the following: *Digital input* [0], *Serial communication* [1], *Logic and* [2] or *Logic or* [3].

Digital input [0]		
Setup msb	Setup lsb	Function
0	0	Setup 1
0	1	Setup 2
1	0	Setup 3
1	1	Setup 4

Serial communication [1]		
Setup msb	Setup lsb	Function
0	0	Setup 1
0	1	Setup 2
1	0	Setup 3
1	1	Setup 4

Logic and [2]				
Bus Set- up msb	Bus Set- up lsb	Dig. Set- up msb	Dig. Set- up lsb	Setup no.
0	0	0	0	1
0	0	0	1	1
0	0	1	0	1
0	0	1	1	1
0	1	0	0	1
0	1	0	1	2
0	1	1	0	1
0	1	1	1	2
1	0	0	0	1
1	0	0	1	1
1	0	1	0	3
1	0	1	1	3
1	1	0	0	1
1	1	0	1	2
1	1	1	0	3
1	1	1	1	4

Logic or [3]				
Bus Set- up msb	Bus Set- up lsb	Dig. Set- up msb	Dig. Set- up lsb	Setup no.
0	0	0	0	1
0	0	0	1	2
0	0	1	0	3
0	0	1	1	4
0	1	0	0	2
0	1	0	1	2
0	1	1	0	4
0	1	1	1	4
1	0	0	0	3
1	0	0	1	4
1	0	1	0	3
1	0	1	1	4
1	1	0	0	4
1	1	0	1	4
1	1	1	0	4
1	1	1	1	4

★ = factory setting, () = display text, [] = value for use in communication via serial communication port

**508 Selection of preset ref.
(PRES.REF. SELECT)**
Value:

Digital input (DIGITAL INPUT)	[0]
Serial communication (SERIAL PORT)	[1]
Logic and (LOGIC AND)	[2]
★ Logic or (LOGIC OR)	[3]

Function:

See function description of parameter 502 *Coasting stop*.

Description of choice:

Preset references via serial communication are active when parameter 512 *Telegram profile* is set to *FC protocol* [1].

**509 Bus jog 1 (BUS JOG 1 FREQ.)
510 Bus jog 2 (BUS JOG 2 FREQ.)**
Value:

0.0 - par. 202 *Output frequency high limit* ★ 10,0 Hz

Function:

If parameter 512 *Telegram Profile* shows the selection *Profidrive* [0], two fixed speeds (Jog 1 or Jog 2) can be selected via the serial port.

The function is the same as in parameter 213 *Jog frequency*.

Description of choice:

Jog frequency f_{JOG} can be selected between 0 Hz and f_{MAX} .

**512 Telegram Profile
(Telegram Profile)**
Value:

Profidrive (Profidrive)	[0]
★ FC protocol (FC protocol)	[1]

Function:

It is possible to choose between two different control word profiles.

Description of choice:

Select the desired control word profile.

See *Serial port for VLT 2800* for further details of control word profiles.

**513 Bus time interval
(BUS TIMEOUT TIME)**
Value:

1 - 99 sec. ★ 1 sec.

Function:

In this parameter it is possible to preset the maximum time expected to elapse between receipt of two consecutive telegrams. If this time is exceeded, the serial communication is assumed to have stopped and the desired reaction is preset in parameter 514 *Bus time interval function*.

Description of choice:

Preset the required time.

**514 Bus time interval function
(BUS TIMEOUT FUNC)**
Value:

★ Off (off)	[0]
Freeze output frequency (FREEZE OUTPUT)	[1]
Stop (STOP)	[2]
Jogging (JOGGING)	[3]
Max. speed (MAX SPEED)	[4]
Stop and trip (STOP AND TRIP)	[5]

Function:

In this parameter you can select the required reaction for the variable frequency drive when the preset time in parameter 513 *Bus time interval* has been exceeded. If choices [1] to [5] are activated the output relay will be deactivated.

Description of choice:

The output frequency of the variable frequency drive can be frozen at the present value, stop the motor, be frozen at parameter 213 *Jogging frequency*, be frozen at parameter 202 *Output frequency, high limit f_{MAX}* or stop and activate a cut out.

★ = factory setting, () = display text, [] = value for use in communication via serial communication port

515-544 Data readout

Value:

Par. no.	Description	Display text	Unit	Update interval
515	Res. reference	(REFERENCE %)	%	
516	Res. reference [Unit]	(REFERENCE [UNIT])	Hz, rpm	
517	Feedback [Unit]	(FEEDBACK [UNIT])	Par. 416	
518	Frequency	(FREQUENCY)	Hz	
519	Frequency x scale	(FREQUENCY X SCALE)	Hz	
520	Motor current	(MOTOR CURRENT)	Amp	
521	Torque	(TORQUE)	%	
522	Power[kW]	(POWER (KW))	kW	
523	Power[HP]	(POWER (HP))	HP	
524	Motor voltage	(MOTOR VOLTAGE)	V	
525	DC-link voltage	(DC LINK VOLTAGE)	V	
526	Thermal load motor	(MOTOR THERMAL)	%	
527	Thermal load inverter	(INV. THERMAL)	%	
528	Digital input	(DIGITAL INPUT)	Bin	
529	Term.53, analogue input	(ANALOG INPUT 53)	V	
531	Term.60, analogue input	(ANALOG INPUT 60)	mA	
532	Pulse reference	(PULSE REFERENCE)	Hz	
533	External ref.	(EXT. REF.%)	%	
534	Status word, Hex	(STATUS WORD)	Hex	
535	Bus feedback 1	(BUS FEEDBACK1)	Hex	
537	Inverter temperature	(INVERTER TEMP.)	°C	
538	Alarm word	(ALARM WORD)	Hex	
539	Control word	(CONTROL WORD)	Hex	
540	Warning word	(WARN. WORD)	Hex	
541	Extended status word	(STATUS WORD)	Hex	
544	Pulse count	(PULSE COUNT)		

Function:

These parameters can be read out via the serial communication port and the LCP display. See also parameters 009-012 *Display readout*.

NOTE

Parameters 515-541 can only be read out via an LCP control unit.

Description of choice:

Resulting reference %, parameter 515:

Gives the resulting reference as a percentage in the range from Minimum reference, Ref_{MIN} to Maximum reference, Ref_{MAX}. See also *Dealing with references*.

Resulting reference [unit], parameter 516:

Gives the resulting reference in Hz in Open loop (parameter 100). In a closed loop the reference unit is selected in parameter 416 *Process units*.

Feedback [unit], parameter 517:

Gives the resulting feedback value with the unit/scaling selected in parameters 414, 415 and 416. See also dealing with feedback.

Frequency [Hz], parameter 518:

Gives the output frequency from the adjustable frequency drive.

Frequency x scaling [-], parameter 519:

corresponds to the present output frequency f_M multiplied by the factor preset in parameter 008 *Display scaling of output frequency*.

★ = factory setting, () = display text, [] = value for use in communication via serial communication port

Motor current [A], parameter 520:

Gives the motor's phase current measured as an effective value.

Torque [Nm], parameter 521:

Gives the motor's present load in relation to the motor's rated torque.

Power [kW], parameter 522:

Gives the present power absorbed by the motor in kW.

Power [HP], parameter 523:

Gives the present power absorbed by the motor in HP.

Motor voltage, parameter 524:

Gives the voltage being supplied to the motor.

DC link voltage, parameter 525:

Gives the intermediate circuit voltage in the adjustable frequency drive.

Thermal load, motor [%], parameter 526:

Gives the calculated/estimated thermal load on the motor. 100% is the cut-out limit. See also parameter 128 *Thermal motor protection*.

Thermal load INV [%], parameter 527:

Gives the calculated/estimated thermal load on the adjustable frequency drive. 100% is the cut-out limit.

Digital input, parameter 528:

Gives the signal status from the 5 digital inputs (18, 19, 27, 29 and 33). Input 18 corresponds to the bit on the extreme left. '0' = no signal, '1' = connected signal.

Terminal 53 analogue input [V], parameter 529:

Gives the voltage value for the signal on terminal 53.

Terminal 60 analogue input [mA], parameter 531:

Gives the present value for the signal on terminal 60.

Pulse reference [Hz], parameter 532:

Gives a pulse frequency in Hz connected to terminal 33.

External reference, parameter 533:

Gives the sum of external references as a percentage (sum of analogue/pulse/serial communication) in the range from Minimum reference, Ref_{MIN} to Maximum reference, Ref_{MAX}.

Status word, parameter 534:

Gives the present status word for the adjustable frequency drive in Hex. See *Serial communication for the VLT 2800*.

Bus feedback 1, parameter 535:

Allows writing of a bus feedback value which will then form part of the feedback handling.

Inverter temperature, parameter 537:

Gives the present inverter temperature on the adjustable frequency drive. The cut-out limit is 90-100 °C, with cut back in at 70 ± 5 °C.

Alarm word, parameter 538:

Gives in Hex code which alarm is on the adjustable frequency drive. See *Warning word, extended status word and alarm word*.

Control word, parameter 539:

Gives the present control word on the adjustable frequency drive in Hex. See *Serial communication for the VLT 2800*.

Warning word, parameter 540:

States whether there is a warning on the adjustable frequency drive in Hex. See *Warning word, extended status word and alarm word*.

Extended status word, parameter 541:

States whether there is a warning on the adjustable frequency drive in Hex code. See *Warning word, extended status word and alarm word*.

Pulse count, parameter 544:

This parameter can be read out via the LCP display (009-012). When you run with counter stop, this parameter enables you, either with or without reset, to read the number of pulses registered by the device. The highest frequency is 67.6 kHz, while the lowest is 5 Hz. The counter is reset when counter stop is restarted.

560 N2 Override release time

(N2 OVER.REL.TIME)

Value:

1 - 65534 (OFF) sec.

★ OFF

Function:

In this parameter, the maximum time that is expected to pass between the reception of two consecutive N2 telegrams is set. If this time is exceeded, the serial communication is assumed to have stopped, and all points in the N2 point-map that are overridden will be released in the order below:

★ = factory setting, () = display text, [] = value for use in communication via serial communication port

1. Release Analog Outputs from point address (NPA) 0 to 255.
2. Release Binary Outputs from point address (NPA) 0 to 255.
3. Release Internal Floating Points from point address (NPA) 0 to 255.
4. Release Internal Integer Points from point address (NPA) 0 to 255.
5. Release Internal Byte points from point address (NPA) 0 to 255.

Description of choice:

Set the required time.

561	Protocol	
(PROTOCOL)		
Value:		
★ FC protocol (FC PROTOKOL)		[0]
Metasys N2 (METASYS N2)		[1]
Modbus RTU		[2]

Function:

There is a choice of three different protocols.

Description of choice:

Select the required control word protocol.

For further information about using the Metasys N2 Protocol, see MG91CX; for Modbus RTU, see MG10SX.

570	Modbus parity and message framing	
(M.BUS PAR./FRAME)		
Value:		
(EVEN/1 STOPBIT)		[0]
(ODD/1 STOPBIT)		[1]
★ (NO PARITY/1 STOPBIT)		[2]
(NO PARITY/2 STOPBIT)		[3]

Function:

This parameter sets up the drive's Modbus RTU interface to communicate properly with the master control-

ler. The parity (EVEN, ODD, or NO PARITY) must be set to match the setting of the master controller.

Description of choice:

Select the parity that matches the setting for the Modbus master controller. Even or odd parity is sometimes used to allow a transmitted word to be checked for errors. Because Modbus RTU uses the more efficient CRC (Cyclic Redundancy Check) method of checking for errors, parity checking is seldom used in Modbus RTU networks.

571 Modbus communications timeout (M.BUS COM.TIME.)

Value:

10 ms - 2000 ms ★ 100 ms

Function:

This parameter determines the maximum amount of time that the drive's Modbus RTU will wait between characters that are sent by the master controller. When this amount of time expires, the drive's Modbus RTU interface will assume that it has received the entire message.

Description of choice:

Generally, the value of 100 ms is sufficient for Modbus RTU networks, although some Modbus RTU networks may operate on a timeout value as short as 35 ms. If this value is set too short, the drive's Modbus RTU interface may miss a part of the message. Since the CRC check will not be valid, the drive will ignore the message. The resulting retransmissions of messages will slow communications on the network.

If this value is set too long, the drive will wait longer than necessary to determine that the message is completed. This will delay the drive's response to the message and possibly cause the master controller to time out. The resulting retransmissions of messages will slow communications on the network.

580-582 Defined parameters (defined pnu's)

Value:

Read only

★ = factory setting, () = display text, [] = value for use in communication via serial communication port

Function:

The three parameters hold a list of all the parameters that are defined in the VLT 2800. It is possible to read single elements of the list by using the corresponding subindex. The subindexes start at 1 and follow the order of the parameter numbers.

Each parameter holds up to 116 elements (parameter numbers).

When a 0 is returned as parameter number the list ends.

■ Technical functions

600-605 Operating Data				
Value:				
Par. no.	Description	Display text	Unit	Range
600	Operating hours	(OPERATING HOURS)	Hours	0-130,000.0
601	Hours run	(RUNNING HOURS)	Hours	0-130,000.0
602	kWh counter	(KWH COUNTER)	kWh	Depends on unit
603	Number of power-ups	(POWER-UPS)	Number of times	0-9999
604	Number of overtemperatures	(OVERTEMPS)	Number of times	0-9999
605	Number of overvoltages	(OVERTOLTS)	Number of times	0-9999

Function:

These parameters can be read out via the serial communication port and the LCP control unit.

Description of choice:

Parameter 600, Operating hours:

Gives the number of hours the adjustable frequency drive has been operating. The value is saved every hour and when there is a line failure. This value cannot be reset.

Parameter 601, Hours run:

Gives the number of hours the motor has been operating since the reset in parameter 619 *Reset of hours run counter*. The value is saved every hour and when there is a line failure.

Parameter 602, kWh counter:

Gives the adjustable frequency drive's output energy in kWh. The calculation is based on the mean kW value over one hour. This value can be reset using parameter 618 *Reset of kWh counter*.

Range: 0 - depends on unit.

Parameter 603, Number of power-ups:

Gives the number of power-ups of the supply voltage undertaken on the adjustable frequency drive.

Parameter 604, Number of overtemperatures:

gives the number of overtemperature faults that have been registered on the adjustable frequency drive's heatsink.

Parameter 605, Number of overvoltages:

gives the number of overvoltages of the intermediate circuit voltage in the adjustable frequency drive. This is only counted when Alarm 7 *Overvoltage* is active.

NOTE

Parameters 615-617 *Fault log* cannot be read out via the integral control unit.

615 Fault log: Error code
(F.LOG: ERROR COD)
Value:

[Index 1 - 10] Error code: 0 - 99

Function:

In this parameter it is possible to see the reason for a trip (cut-out of the variable frequency drive) occurring. 10 [1-10] log values are defined.

The lowest log number [1] contains the latest/most recently saved data value. The highest log number [10] contains the oldest data value saved. If a trip occurs, it is possible to see the cause, time and a possible value of the output current or output voltage.

Description of choice:

Given as a fault code, in which the number refers to a table. See the table in *Warnings/alarm messages*.

616 Fault log: Time
(F. LOG: TIME)
Value:

[Index 1 - 10] Hours: 0 - 130,000.0

Function:

In this parameter, it is possible to see the total number of operating hours in connection with the last 10 trips. 10 [1-10] log values are denoted. The lowest log number [1] contains the latest/most recently saved data value, and the highest log number [10] contains the oldest data value.

Description of choice:

Read out as one value.

★ = factory setting, () = display text, [] = value for use in communication via serial communication port

617 Fault log: Value
(F.LOG: VALUE)

Value:
[Index 1 - 10] Value: 0 - 9999

Function:
In this parameter it is possible to see at which value a trip occurred. The unit of the value depends on which alarm is active in parameter 615 *Fault log: Fault code* .

Description of choice:
Read out as one value.

618 Reset of kWh counter
(RESET KWH COUNT)

Value:

★ No reset (DO NOT RESET)	[0]
Reset (RESET COUNTER)	[1]

Function:
Resetting parameter 602 *kWh counter* to zero.

Description of choice:
If *Reset* [1] is selected and you press the [OK] key, the variable frequency drive's kWh counter is reset to zero. This parameter cannot be selected via serial communication.



NOTE
When the [OK] key is activated, the counter is reset to zero.

619 RESET RUNNING HOURS COUNTER
(RESET RUN. HOUR)

Value:

★ No reset (DO NOT RESET)	[0]
Reset (RESET COUNTER)	[1]

Function:
Resetting of parameter 601 *Hours run* to zero.

Description of choice:

If *Reset* [1] is selected and you press the [OK] key, the variable frequency drive's parameter 601 is reset to zero *Hours run*. This parameter cannot be selected via serial communication.



NOTE
When the [OK] key is activated the parameter is reset to zero.

620 Operation Mode
(OPERATION MODE)

Value:

★ Normal operation (NORMAL OPERATION)	[0]
Control card test (CONTROL CARD TEST)	[2]
Initialize (INITIALIZE)	[3]

Function:
In addition to its normal function, this parameter can be used to test the control card. There is also the opportunity to perform an initialization at the factory setting for all parameters in all Setups, with the exception of parameters 500 *Address*, 501 *Baudrate*, 600-605 *Operating data* and 615-617 *Fault log*.

Description of choice:

Normal function [0] is used for normal operation of the motor.

Control card test [2] is selected if you wish to check the control card's analog/digital inputs, analog/digital outputs, relay outputs and 10 V and 24 V voltages.

The test is performed as follows:

27 - 29 - 33 - 46 are connected.

50 - 53 are connected.

42 - 60 are connected.

12 - relay terminal 01 is connected.

18 - relay terminal 02 is connected.

19 - relay terminal 03 is connected.

See also the DeviceNet manual MG.90.BX.YY for further details.

★ = factory setting, () = display text, [] = value for use in communication via serial communication port

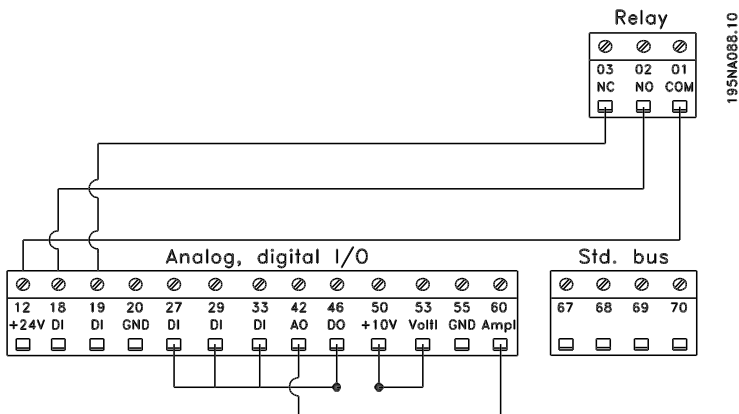

Use the following procedure for the control card test:

1. Select control card test.
2. Disconnect the AC line voltage and wait until the light in the display has disappeared.
3. Mount according to drawing and description.
4. Connect the AC line voltage.
5. The adjustable frequency drive automatically undertakes a test of the control card.

If the adjustable frequency drive displays a fault code from 37-45, the control card test has failed. Change the control card to start up the adjustable frequency drive.

If the adjustable frequency drive comes into Display mode, the test is OK. Remove the test connector and the adjustable frequency drive is ready for operation. Parameter 620 *Operating mode* is automatically set to *Normal operation* [0].

Initialization [3] is selected if you wish to use the unit's factory setting.

Procedure for initialization:

1. Select *Initialization* [3].
2. Disconnect the AC line voltage and wait until the light in the display has disappeared.
3. Connect the AC line voltage.
4. An initialization is performed in all parameters in all Setups, with the exception of parameters 500 *Address*, 501 *Baudrate*, 600-605 *Operating data* and 615-617 *Fault log*.

★ = factory setting, () = display text, [] = value for use in communication via serial communication port

VL^T® 2800 Series

621-642 Nameplate

Value:

Par. no	Description Nameplate	Display text
621	Unit type	(DRIVE TYPE)
624	Software version	(SOFTWARE VERSION)
625	LCP identification no.	(LCP VERSION)
626	Database identification no.	(DATABASE VER.)
627	Power parts version	(POWER UNIT DB ID)
628	Application option type	(APP. OPTION)
630	Communication option type	(COM. OPTION)
632	BMC software identification	(BMC SOFTWARE ID)
634	Unit identification for communication	(UNIT ID)
635	Software parts no.	(SW. PART NO.)
640	Software version	(SOFTWARE VERSION)
641	BMC software identification	(BMC2 SW)
642	Power card identification	(POWER ID)

Function:

The unit's main data can be read out from parameters 621 to 635 *Nameplate* using the LCP 2 control unit or serial communication. Parameters 640-642 can also be seen on the unit's integral display.

Description of choice:

Parameter 621 Nameplate: Unit type:

Gives unit size and line voltage.

Example: VLT 2811 380 - 480 V.

Parameter 624 Nameplate: Software version no.

The unit's present software version number appears here.

Example: V 1.00

Parameter 625 Nameplate: LCP 2 ID number:

The ID number of the unit's LCP 2 appears here.

Example: ID 1.42 2 kB

Parameter 626 Nameplate: Database ID number:

The ID number of the software's database appears here.

Example: ID 1.14.

Parameter 627 Nameplate: Power section version:

The ID number of the unit's power section appears here.

Example: ID 1.15.

Parameter 628 Nameplate: Application option type:

Here you can see which types of application options are installed in the adjustable frequency drive.

Parameter 630 Nameplate: Communication option type:

Here you can see which types of communication options are installed in the adjustable frequency drive.

Parameter 632 Nameplate: BMC software identification:

The ID number of the BMC software appears here.

Parameter 634 Nameplate: Unit identification for communication:

The ID number for communication appears here.

Parameter 635 Nameplate: Software section no.:

The software section number appears here.

Parameter 640 Nameplate: Software version:

The unit's present software version number appears here. Example: 1.00

Parameter 641 Nameplate: BMC software identification:

The ID number of the BMC software appears here.

Parameter 642 Nameplate: Power card identification:

The ID number of the unit's power part appears here. Example: 1.15

Parameter 700 -

Only for wobble functions: To use this function or for further information, please see MI29J2xx.

678 Configure Control Card**(CONFIG CONTROL CARD)****Value:**

- Standard version (STANDARD VERSION) [1]
- Profibus 3 Mbaud Version (PROFIBUS 3 MB Ver.) [2]
- Profibus 12 Mbaud Version (PROFIBUS 12 MB Ver.) [3]

Function:

This parameter enables a configuration of a Profibus control card. The default value depends on the produced unit, which is also the maximum obtainable value. This means that a control card can only be downgraded to a lower performance version.

■ Warnings/alarm messages

A warning or an alarm will appear in the display as a numerical code **Err. xx**. A warning will be shown on the display until the fault has been corrected, while an alarm will continue to flash until the [STOP/RESET] key is activated. The table shows the various warnings and alarms, and whether the fault locks the adjustable frequency drive. After a *Trip-locked* the line supply is cut off and the fault is corrected. The line supply is re-connected and the adjustable frequency drive is reset. The adjustable frequency drive is now ready. A *Trip* can be reset manually in three ways:

1. Via the operating key [STOP/RESET].
2. Via a digital input.

3. Via serial communication.

It is also possible to choose an automatic reset in parameter 405 *Reset function*. When a cross appears in both warning and alarm, this can mean that a warning comes before an alarm. It can also mean that it is possible for the user to program whether a warning or an alarm will appear for a given fault. For example, this is possible in parameter 128 *Motor thermal protection*. After a trip, the motor will coast, and alarm and warning will blink on the adjustable frequency drive; but if the fault disappears, only the alarm will blink. After a reset, the adjustable frequency drive will be ready to start operation again.

No	Description	Warning	Alarm	Trip locked
2	Live zero error (LIVE ZERO ERROR)	X	X	X
4	Line phase loss (LINE PHASE LOSS)	X	X	X
5	Voltage warning high (DC LINK VOLTAGE HIGH)	X		
6	Voltage warning low (DC LINK VOLTAGE LOW)	X		
7	Overvoltage (DC LINK OVERVOLT)	X	X	X
8	Undervoltage (DC LINK UNDERVOLT)	X	X	X
9	Inverter overload (INVERTER TIME)	X	X	
10	Motor overloaded (MOTOR, TIME)	X	X	
11	Motor thermistor (MOTOR THERMISTOR)	X	X	
12	Current limit (CURRENT LIMIT)	X	X	
13	Overcurrent (OVERCURRENT)	X	X	X
14	Ground fault (GROUND FAULT)		X	X
15	Switch mode fault (SWITCH MODE FAULT)		X	X
16	Short-circuit (CURR. SHORT CIRCUIT)		X	X
17	Serial communication timeout (STD BUS TIMEOUT)	X	X	
18	HPFB bus timeout (HPFB TIMEOUT)	X	X	
33	Out of frequency range (OUT FREQ RNG/ROT LIM)	X		
34	HPFB communication fault (PROFIBUS OPT. FAULT)	X	X	
35	Soft-charge fault (SOFT-CHARGE FAULT)		X	X
36	Overtemperature (OVERTEMPERATURE)	X	X	
37-45	Internal fault (INTERNAL FAULT)		X	X
50	AMT not possible		X	
51	AMT fault re. nameplate data (AMT TYPE.DATA FAULT)		X	
54	AMT wrong motor (AMT WRONG MOTOR)		X	
55	AMT timeout (AMT TIMEOUT)		X	
56	AMT warning during AMT (AMT WARN. DURING AMT)		X	
99	Locked (LOCKED)	X		

LED indication

Warning	yellow
Alarm	red
Trip-locked	yellow and red

WARNING/ALARM 2: Live zero fault

The voltage or current signal on terminal 53 or 60 is below 50% of the preset value in parameter 309 or 315 *Terminal, min. scaling*.

WARNING/ALARM 4: Mains phase fault

No phase on mains supply side. Check the supply voltage to the adjustable frequency drive. This fault is only active in 3-phase mains supply. The alarm can also occur when the load is pulsing. In this instance the pulses must be dampened, e.g. using an inertia disc.

WARNING 5: Voltage warning high

If the intermediate circuit voltage (UDC) is higher than *Voltage warning high* the adjustable frequency drive will give a warning and the motor will continue to run unchanged. If the UDC remains above the voltage warning limit, the inverter will trip after a set time. The time depends on the device, and is set at 5 - 10 sec. Note: The adjustable frequency drive will trip with an alarm 7 (overvoltage). A voltage warning can occur when the connected mains voltage is too high. Check whether the supply voltage is suitable for the adjustable frequency drive, see *Technical data*. A voltage warning can also occur if the motor frequency is reduced too quickly due to ramp down time being too short.

WARNING 6: Voltage warning low

If the intermediate circuit voltage (UDC) is lower than *Voltage warning low* the adjustable frequency drive will give a warning and the motor will continue to run unchanged. A voltage warning can occur when the connected mains voltage is too low. Check whether the supply voltage is suitable for the adjustable frequency drive, see *Technical data*. When the adjustable frequency drive is switched off a brief warning 6 (and warning 8) appears.

WARNING/ALARM 7: Overvoltage

If the intermediate voltage (UDC) goes over the inverter's *Overvoltage limit* the inverter will be switched off until the UDC has once more fallen below the overvoltage limit. If the UDC remains above the overvoltage limit the inverter will trip after a set time. The time depends on the device, and is set at 5 - 10 sec. An overvoltage in the UDC can occur when the motor frequency is reduced too quickly due to ramp down time being too short. When the inverter is switched off a trip reset is generated. Note: *Voltage warning high* (warning 5) will thus also be able to generate an alarm 7.

WARNING/ALARM 8: Undervoltage

If the intermediate circuit voltage (UDC) is lower than the inverter's *Undervoltage limit* the inverter will be switched off until the UDC once more goes above the undervoltage limit. If the UDC remains under the *un-*

der voltage limit, the inverter will trip after a set time. The time depends on the device, and is set at 2 - 15 sec. An undervoltage can occur when the connected mains voltage is too low. Check whether the supply voltage is suitable for the adjustable frequency drive, see *Technical data*. When the adjustable frequency drive is switched off a alarm 8 (and alarm 6) is displayed briefly and a trip reset is generated. Note: *Voltage warning low* (warning 6) will thus also be able to generate an alarm 8.

WARNING/ALARM 9: Inverter overload

Electronic thermal inverter protection indicates that the adjustable frequency drive is close to tripping due to overloading (output current too high for too long). The counter for electronic thermal inverter protection gives a warning at 98% and trips at 100% accompanied by an alarm. The adjustable frequency drive cannot be reset until the counter drops below 90%. This fault arises because the adjustable frequency drive has been overloaded for too long.

WARNING/ALARM 10: Motor overloaded

According to the electronic thermal inverter protection the motor is too hot. In parameter 128 the user can select whether the adjustable frequency drive should emit a warning or an alarm when the counter reaches 100%. This fault is due to the motor being overloaded by more than 100% for too long. Check that motor parameters 102-106 are set correctly.

WARNING/ALARM 11: Motor thermistor

The motor is too hot or the thermistor/thermistor connection has been disconnected. In parameter 128 *Thermal motor protection* the user can select whether the frequency transformer emits a warning or an alarm. Check that the PTC thermistor is correctly connected between terminals 18, 19, 27 or 29 (digital input) and terminal 50 (+ 10 V supply).

WARNING/ALARM 12: Current limit

The output current is greater than the value in parameter 221 *Current Limit LIM*, and the adjustable frequency drive will trip after a set time, selected in parameter 409 *Trip delay overcurrent*.

WARNING/ALARM 13: Overcurrent

The inverter's peak current limit (approx. 200% of rated output current) has been exceeded. The warning will last approx. 1-2 sec, and the adjustable frequency drive will then trip and emit an alarm. Switch off the adjustable frequency drive and check whether the motor shaft can be turned, and whether the size of the motor is suitable for the adjustable frequency drive.

ALARM 14: Earth fault

There is a discharge from the output phases to earth, either in the cable between the adjustable frequency drive and the motor, or in the motor. Turn off the adjustable frequency drive and remove the earth fault.

ALARM 15: Switch mode fault

Fault in switch mode power supply (internal supply). Contact your Danfoss supplier.

ALARM: 16: Short-circuit

There is a short-circuit on the motor terminals or in the motor. Disconnect the mains supply to the adjustable frequency drive and remove the short-circuit.

WARNING/ALARM 17: Serial communication timeout

There is no serial communication to the adjustable frequency drive. The warning will only be active when 514 *Bus timeout function* is set to a value other than OFF. If parameter 514 *Bus timeout function* is set to *Stop and trip* [5], it will first give a warning and then ramp down and trip out accompanied by an alarm. Parameter 513 *Bus timeout* can if required be increased.

WARNING/ALARM 18: HPFB bus timeout

There is no serial communication to the adjustable frequency drive's communication option card. This warning will only be active when parameter 804 *Bus timeout function* is set to a value other than OFF. If parameter 804 *Bus timeout function* is set to *Stop and trip*, it will first give a warning and then ramp down and trip out accompanied by an alarm. Parameter 803 *Bus timeout* can if required be increased.

WARNING 33: Out of frequency range

This warning is active if the output frequency has reached *Output frequency low limit* (parameter 201) or *Output frequency high limit* (parameter 202). If the adjustable frequency drive is in *Process regulation, closed loop* (parameter 100) the warning will be active in the display. If the adjustable frequency drive is in another mode than *Process regulation, closed loop*, bit 008000

Out of frequency range in extended status word will be active, but there will not be a warning in the display.

WARNING/ALARM 34: HPFB communication fault

Communication fault only occurs in Fieldbus versions. Regarding alarmtype, please see parameter 953 in fieldbus literature.

ALARM 35: Inrush fault

This alarm occurs when the adjustable frequency drive has been connected to the mains supply too many times within 1 minute.

WARNING/ALARM 36: Overtemperature

If the temperature inside the power module rises above 75 - 85 °C (depending on the device) the adjustable frequency drive will emit a warning, and the motor will continue to run unchanged. If the temperature continues to rise, the switch frequency is reduced automatically. See *Temperature-dependent switching frequency*.

If the temperature inside the power module rises above 92 - 100 °C (depending on the unit) the adjustable frequency drive will cut out. The temperature fault cannot be reset until the temperature has dropped to below 70 °C. The tolerance is ± 5 °C. The temperature can be caused by the following:

- The ambient temperature too high.
- Motor cable too long.
- Too high mains voltage.

ALARM 37-45: Internal fault

If one of these failures occurs, please contact Danfoss.

Alarm 37, internal fault number 0: Communication fault between control card and BMC.

Alarm 38, internal fault number 1: Flash EEPROM fault on control card.

Alarm 39, internal fault number 2: RAM fault on control card.

Alarm 40, internal fault number 3: Calibration constant in EEPROM.

Alarm 41, internal fault number 4: Data values in EEPROM.

Alarm 42, internal fault number 5: Fault in motor parameter database.

Alarm 43, internal fault number 6: General power card fault.

Alarm 44, internal fault number 7: Minimum software version of control card or BMC.

Alarm 45, internal fault number 8: I/O fault (digital input/output, relay or analog input/output).



NOTE

When restarting after an alarm 38-45, the adjustable frequency drive will display an alarm 37. In parameter 615 the actual alarm code can be read.

ALARM 50: AMT not possible

One of the following three possibilities can occur:

- The calculated R_s value falls outside permitted limits.
- The motor current in at least one of the motor phases is too low.

- The motor in use is too small for AMT calculations to be performed.

ALARM 51: AMT Fault regarding nameplate data

There is inconsistency between the registered motor data. Check the motor data for the relevant setup.

ALARM 52: AMT missing motor phase

The AMT function has detected a missing motor phase.

ALARM 55: AMT timeout

Calculations are taking too long, possibly due to noise on the motor cables.

ALARM 56: AMT warning during AMT

A adjustable frequency drive warning is given while AMT is being performed.

WARNING 99: Locked

See parameter 18.

Alarm/warning limits:

	Without brake	With brake	Without brake	With brake
VLT 2800	1 / 3 x 200 - 240 V [VDC]	1 / 3 x 200 - 240 V [VDC]	3 x 380 - 480 V [VDC]	3 x 380 - 480 V [VDC]
Undervoltage	215	215	410	410
Voltage warning low	230	230	440	440
Voltage warning high	385	400	765	800
Overvoltage	410	410	820	820

The voltages stated are the intermediate circuit voltage of the adjustable frequency drive with a tolerance of $\pm 5\%$. The corresponding line voltage is the intermediate circuit voltage divided by 1,35.

■ **Warning words, extended status words and alarmwords**

Warning words, status words and alarm words appear in the display in Hex format. If there are several warnings, status words or alarms, a total of all will be displayed. Warning words, status words and alarm words can also be read out using the serial bus in parameters 540, 541 and 538 respectively.

Bit (Hex)	Warning words
000008	HPFB bus timeout
000010	Standard bus timeout
000040	Current limit
000080	Motor thermistor
000100	Motor overload
000200	Inverter overload
000400	Undervolt
000800	Overvolt
001000	Voltage warning low
002000	Voltage warning high
004000	Phase loss
010000	Live zero error
400000	Out of frequency range
800000	Profibus communication fault
40000000	Switch mode warning
80000000	Heat sink temperature high

Bit (Hex)	Extended status words
000001	Ramping
000002	AMT running
000004	Start forw./reverse
000008	Slow down
000010	Catch-up
000020	Feedback high
000040	Feedback low
000080	Output current high
000100	Output current low
000200	Output frequency high
000400	Output frequency low
002000	Braking
008000	Out of frequency range

Bit (Hex)	Alarm words
000002	Triplock
000004	AMT tuning fail
000040	HPFB bus timeout
000080	Standard bus timeout
000100	Curr. short circuit
000200	Switch mode fault
000400	Ground fault
000800	Overcurrent
002000	Motor thermistor
004000	Motor overload
008000	Inverter overload
010000	Undervolt
020000	Overvolt
040000	Phase loss
080000	Live zero error
100000	Heat sink temperature too high
2000000	Profibus communication fault
8000000	Inrush fault
10000000	Internal fault

■ Special conditions

■ Extreme environments

An adjustable frequency drive contains a number of mechanical and electronic components which are vulnerable to environmental impact.



Do not install the adjustable frequency drive in environments where liquids, particles or gases in the air would damage the electronics of the drive. Take all necessary measures to protect the drive. There is a risk of fault trips and reduced service life of the drive.

Liquids carried through the air can condense in the adjustable frequency drive. Liquids may facilitate galvanic corrosion of components and metal parts. Steam, oil and brine may also cause corrosion of components and metal parts. In these areas, it is recommended to install units in cabinets. As a minimum, cabinets should meet NEMA 12.

Particles in the air, such as dust, may lead to mechanical, electrical and thermal faults in the adjustable frequency drive. A typical indicator of too many particles in the air is dust around the fan. In very dusty areas, mounting the drive in a cabinet is recommended. As a minimum, cabinets should meet NEMA 12.

Aggressive gases, such as sulfur, nitrogen and chlorine compounds, together with high humidity and temperature, facilitate possible chemical processes on the components of the adjustable frequency drive. These chemical processes quickly damage the electronics. In these areas, mounting in a cabinet with fresh-air circulation is recommended, thereby ensuring that aggressive gases are kept away from the drive.



NOTE

Installation of adjustable frequency drives in extreme environments increases the risk of down-time, and considerable reduction of the service life of the drive.

Before the adjustable frequency drive is installed, check whether there are liquids, particles or gases in the air. Examine existing installations in the same environment. Typical indicators of harmful airborne liquids are water or oil on metal parts or corrosion. Too many dust particles are typically observed on top of cabinets. Indication of aggressive gases in the air are

black copper rails and cable ends on existing electrical installations.

■ Galvanic Isolation (PELV)

PELV (Protective Extra Low Voltage) insulation is achieved by inserting galvanic isolators between the control circuits and circuits that are connected to the line power potential. The VLT is designed to meet the requirements for protective separation by means of having the necessary creepage and clearance distances. These requirements are described in standard EN 50 178. It is also a requirement that the installation is carried out in accordance with local/national regulations regarding PELV.

All control terminals, terminals for serial communication and relay terminals are safely separated from the line power potential, which is to say that they comply with the PELV requirements. Circuits that are connected to control terminals 12, 18, 19, 20, 27, 29, 33, 42, 46, 50, 53, 55 and 60 are galvanically connected to one another. Serial communication connected to serial communication bus is galvanically insulated from the control terminals, although this is only a functional insulation.

The relay contacts on terminals 1-3 are insulated from the other control circuits with reinforced/double insulation, i.e., PELV is observed for these, even though there is line power potential at the relay terminals.

The circuit elements described below form the safe electric separation. They fulfill the requirements for reinforced/double insulation and associated testing pursuant to EN 50 178.

1. Transformer and optical separation in voltage supply.
2. Optical insulation between the basic motor control and the control card.
3. Insulation between the control card and the power part.
4. Relay contacts and terminals relating to other circuits on the control card.

PELV insulation of the control card is guaranteed under the following conditions:

- TT network with maximum 300 Vrms between phase and ground.

- TN network with maximum 300 Vrms between phase and ground.
- IT network with maximum 400 Vrms between phase and ground.

In order to maintain PELV, all connections made to the control terminals must be PELV. For example, the thermistor must be reinforced/double insulated.

■ **UL Standard**

This device is UL-approved.

General technical data
Line power supply (L1, L2, L3):

Supply voltage VLT 2803-2840 220-240 V (N, L1)	1 x 220/230/240 V ±10%
Supply voltage VLT 2803-2840 200-240 V	3 x 200/208/220/230/240 V ±10%
Supply voltage VLT 2805-2882 380-480 V	3 x 380/400/415/440/480 V ±10%
Supply voltage VLT 2805-2840 (R5)	380/400 V + 10%
Supply frequency	50/60 Hz ± 3 Hz
Max. imbalance on supply voltage	± 2.0% of rated supply voltage
True Power Factor (λ)	0.90 nominal at rated load
Displacement Power Factor ($\cos \phi$)	near unity (> 0.98)
Number of connections at supply input L1, L2, L3	2 times/min.
Max. short circuit value	100,000 A

See *Special Conditions* section in the *Design Guide*

Output data (U, V, W):

Output voltage	0 - 100% of supply voltage
Output frequency	0.2 - 132 Hz, 1 - 1000 Hz
Rated motor voltage, 200-240 V units	200/208/220/230/240 V
Rated motor voltage, 380-480 V units	380/400/415/440/460/480 V
Rated motor frequency	50/60 Hz
Switching on output	Unlimited
Ramp times	0.02 - 3600 sec.

Torque characteristics:

Starting torque (parameter 101 Torque characteristic = Constant torque)	160% in 1 min.*
Starting torque (parameter 101 Torque characteristics = Variable torque)	160% in 1 min.*
Starting torque (parameter 119 <i>High starting torque</i>)	180% for 0.5 sec.
Overload torque (parameter 101 Torque characteristic = Constant torque)	160%*
Overload torque (parameter 101 Torque characteristic = Variable torque)	160%*

Percentage relates to adjustable frequency drive's nominal current.

* VLT 2822 PD2 / 2840 PD2 1 x 220 V only 110% in 1 min.

Control card, digital inputs:

Number of programmable digital inputs	5
Terminal number	18, 19, 27, 29, 33
Voltage level	0-24 V DC (PNP positive logic)
Voltage level, logic '0'	< 5 V DC
Voltage level, logic '1'	> 10 V DC
Maximum voltage on input	28 V DC
Input resistance, R_i (terminals 18, 19, 27, 29)	approximately 4 k Ω
Input resistance, R_i (terminal 33)	approximately 2 k Ω

All digital inputs are galvanically isolated from the supply voltage (PELV) and other high-voltage terminals. See section entitled *Galvanic Isolation*.



VLT® 2800 Series

Control card, analog inputs:

Number of analog voltage inputs	1 pcs.
Terminal number	53
Voltage level	0 - 10 V DC (scalable)
Input resistance, R_i	approx. 10 k Ω
Max. voltage	20 V
Number of analog current inputs	1 pcs.
Terminal number	60
Current level	0/4 - 20 mA (scalable)
Input resistance, R_i	approx. 300 Ω
Max. current	30 mA
Resolution for analog inputs	10 bit
Accuracy of analog inputs	Max. error 1% of full scale
Scan interval	13.3 msec

The analog inputs are galvanically isolated from the supply voltage (PELV) and other high-voltage terminals. See section entitled Galvanic Isolation.

Control card, pulse inputs:

Number of programmable pulse inputs	1
Terminal number	33
Max. frequency on terminal 33	67.6 kHz (Push-pull)
Max. frequency on terminal 33	5 kHz (open collector)
Min. frequency on terminal 33	4 Hz
Voltage level	0 - 24 VDC (PNP positive logic)
Voltage level, logic '0'	< 5 VDC
Voltage level, logic '1'	> 10 VDC
Maximum voltage on input	28 VDC
Input resistance, R_i	approx. 2 k Ω
Scan interval	13.3 msec
Resolution	10 bit
Accuracy (100 Hz - 1 kHz) terminal 33	Max. error: 0.5% of full scale
Accuracy (1 kHz - 67.6 kHz) terminal 33	Max. error: 0.1% of full scale

The pulse input (terminal 33) is galvanically isolated from the supply voltage (PELV) and other high-voltage terminals. See section entitled Galvanic Isolation.

Control card, digital/frequency outputs:

Number of programmable digital/pulse outputs	1
Terminal number	46
Voltage level at digital/frequency output	0-24 V DC (O.C PNP)
Max. output current at digital/frequency output	25 mA.
Max. load at digital/frequency output	1 k Ω
Max. capacity at frequency output	10 nF
Minimum output frequency at frequency output	16 Hz
Maximum output frequency at frequency output	10 kHz
Accuracy on frequency output	Max. error: 0.2% of full scale
Resolution on frequency output	10 bit

The digital output is galvanically isolated from the supply voltage (PELV) and other high-voltage terminals. See section entitled Galvanic Isolation.



VLT® 2800 Series

Control card, analog output:

Number of programmable analog outputs	1
Terminal number	42
Current range at analog output	0/4 - 20 mA
Max. load to common at analog output	500 Ω
Accuracy on analog output	Max. error: 1.5 % of full scale
Resolution on analog output	10 bit

The analog output is galvanically isolated from the supply voltage (PELV) and other high-voltage terminals. See section entitled Galvanic Isolation.

Control card, 24 V DC output:

Terminal number	12
Max. load	130 mA

The 24 V DC supply is galvanically isolated from the supply voltage (PELV), but has the same potential as the analog and digital inputs and outputs. See section entitled Galvanic Isolation.

Control card, 10 V DC output:

Terminal number	50
Output voltage	10.5 V ±0.5 V
Max. load	15 mA

The 10 V DC supply is galvanically isolated from the supply voltage (PELV) and other high-voltage terminals. See section entitled Galvanic Isolation.

Control card, RS-485 serial communication:

Terminal number	68 (TX+, RX+), 69 (TX-, RX-)
Terminal number 67	+ 5 V
Terminal number 70	Common for terminals 67, 68 and 69

Full galvanic isolation. See section entitled Galvanic Isolation.

For CANopen/DeviceNet units, see VLT 2800 DeviceNet manual, MG.90.BX.YY.

Relay outputs:¹⁾

Number of programmable relay outputs	1
Terminal number, control card (resistive and inductive load)	1-3 (break), 1-2 (make)
Max. terminal load (AC1) on 1-3, 1-2, control card	250 V AC, 2 A, 500 VA
Max. terminal load (DC1 (IEC 947)) on 1-3, 1-2, control card	25 V DC, 2 A / 50 V DC, 1A, 50W
Min. terminal load (AC/DC) on 1-3, 1-2, control card	24 V DC 10 mA, 24 V AC 100 mA

The relay contact is separated from the rest of the circuit by strengthened isolation.

Note: Rated values resistive load - $\cos\phi > 0.8$ for up to 300,000 operations.
Inductive loads at $\cos\phi 0.25$ approximately 50% load or 50% life time.



VLT® 2800 Series

Cable lengths and cross-sections:

Max. motor cable length, shielded/armored cable	131 ft [40 m]
Max. motor cable length, unshielded/unarmored cable	246 ft [75 m]
Max. motor cable length, shielded/armored cable and motor coil	328 ft [100 m]
Max. motor cable length, unshielded/unarmored cable and motor coil	656 ft [200 m]
Max. motor cable length, shielded/armored cable and RFI/1B filter	200 V, 328 ft [100 m]
Max. motor cable length, shielded/armored cable and RFI/1B filter	400 V, 82 ft [25 m]
Max. motor cable length, shielded/armored cable and RFI 1B/LC filter	400 V, 82 ft [25 m]

Max. cross-section to motor, see next section.

Max. cross-section to control wires, rigid wire	0.0023 in. ² [1.5 mm ²]/16 AWG (2 x 0.0012 in. ² [2 x 0.75 mm ²])
Max. cross section to control cables, flexible cable	0.0016 in. ² [1 mm ²]/18 AWG
Max. cross-section to control cables, cable with enclosed core	0.00078 in. ² [0.5 mm ²]/20 AWG

When complying with EN 55011 1A and EN 55011 1B, the motor cable must be reduced in certain instances. See EMC emission.

Control characteristics:

Frequency range	0.2 - 132 Hz, 1 - 1000 Hz
Resolution of output frequency	0.013 Hz, 0.2 - 1000 Hz
Repeat accuracy of <i>Precise start/stop</i> (terminals 18, 19)	• ± 0.5 msec
System response time (terminals 18, 19, 27, 29, 33)	• 26.6 msec
Speed control range (open-loop)	1:10 of synchronous speed
Speed control range (closed-loop)	1:120 of synchronous speed
Speed accuracy (open-loop)	150 - 3600 rpm: Max. error of ±23 rpm
Speed accuracy (closed-loop)	30 - 3600 rpm: Max. error of ±7.5 rpm

All control characteristics are based on a 4-pole asynchronous motor

Surroundings:

Enclosure	IP 20
Enclosure with options	NEMA 1
Vibration test	0.7 g
Max. relative humidity	5%-93% during operation
Ambient temperature	Max. 113° F [45° C] (24-hour average max. 104° F [40° C])

Derating for high ambient temperature, see special conditions in the Design Guide

Min. ambient temperature during full-scale operation	32° F [0° C]
Min. ambient temperature at reduced performance	14° F [-10° C]
Temperature during storage/transport	-13° - +149°/158° F [-25° - +65°/70° C]
Max. altitude above sea level	3,280 ft [1,000 m]

Derating for high air pressure, see special conditions in the Design Guide

EMC standards, Emission	EN 61081-2, EN 61800-3, EN 55011 EN 50082-1/2, EN 61000-4-2, EN 61000-4-3, EN 61000-4-4, EN 61000-4-5, EN
EMC standards, Immunity	61000-4-6, EN 61800-3

See section on special conditions in the Design Guide

Safeguards:

- Electronic thermal motor protection against overload.
- Temperature monitoring of the power module ensures that the adjustable frequency drive cuts out if the temperature reaches 212 °F (100 °C). An overload temperature cannot be reset until the temperature of the power module is below 160 °F (70 °C).
- The frequency converter is protected against short-circuits on motor terminals U, V, W.
- If an electrical phase is missing, the variable frequency drive will cut out.
- Monitoring of the intermediate circuit voltage ensures that the variable frequency drive cuts out if the intermediate circuit voltage is too low or too high.
- The variable frequency drive is protected against ground fault on motor terminals U, V, W.

■ Technical data, mains supply 1 x 220 - 240 V/3 x 200-240V

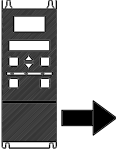
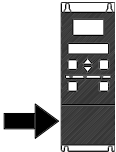
According to . international standards	Type	2803	2805	2807	2811	2815	2822	2822 PD2	2840	2840 PD2	
	Output current (3 x 200-240V)	I_{INV} [A]	2.2	3.2	4.2	6.0	6.8	9.6	16	16	
		I_{MAX} (60s) [A]	3.5	5.1	6.7	9.6	10.8	15.3	25.6	17.6	
	Output power (230 V)	S_{INV} [KVA]	0.9	1.3	1.7	2.4	2.7	3.8	3.8	6.4	6.4
	Typical shaft output	$P_{M,N}$ [kW]	0.37	0.55	0.75	1.1	1.5	2.2	2.2	3.7	3.7
	$P_{M,N}$ [HP]	0.5	0.75	1.0	1.5	2.0	3.0	3.0	5.0	5.0	
Max. cable cross section, motor	[mm ² /AWG] ¹⁾	4/10	4/10	4/10	4/10	4/10	4/10	4/10	4/10	16/6	
	Input current (1 x 220-240 V)	$I_{L,N}$ [A]	5.9	8.3	10.6	14.5	15.2	-	22.0	-	31.0
		$I_{L,MAX}$ (60s) [A]	9.4	13.3	16.7	23.2	24.3	-	24.3	-	34.5
	Input current (3 x 200-240 V)	$I_{L,N}$ [A]	2.9	4.0	5.1	7.0	7.6	8.8	8.8	14.7	14.7
		$I_{L,MAX}$ (60s) [A]	4.6	6.4	8.2	11.2	12.2	14.1	9.7	23.5	16.2
	Max. cable cross section, power	[mm ² /AWG] ¹⁾	4/10	4/10	4/10	4/10	4/10	4/10	4/10	4/10	16/6
	Max. pre-fuses	IEC/UL ²⁾ [A]	20/20	20/20	20/20	20/20	20/20	20/20	35/35	25/25	50/50
	Efficiency ³⁾	[%]	95	95	95	95	95	95	95	95	95
	Power loss at 100% load	[W]	24	35	48	69	94	125	125	231	231
	Weight	[kg]	2.0	2.0	2.0	2.0	2.0	3,7	6.0	6.0	18.50
	Enclosure ⁴⁾	type	IP 20	IP 20	IP 20	IP 20	IP 20	IP 20	IP 20	IP 20	IP 20/ NEMA 1

1. American Wire Gauge. Max. cable cross section is the largest cable cross section that can be attached to the terminals. Always observe national and local regulations.

2. Type gG pre-fuses must be used for installation according to IEC rules. If you want to maintain UL/cUL you must use pre-fuses of the type Bussmann KTN-R 200 V, KTS-R 500 V or Ferraz Shawmut, type ATMR (max. 30A). The fuses must be placed for protection in a circuit that is capable of supplying a maximum of 100,000 amps RMS (symmetrical), 500 V maximum.

3. Measured using a 25 m screened/armoured motor cable with a rated load and rated frequency.

4. IP20 is standard for VLT 2805-2875, whereas NEMA 1 is an option.

■ Technical data, mains supply 3 x 380 - 480 V

According to international standards		Type	2805	2807	2811	2815	2822	2830
	Output current (3 x 380-480V)	I_{INV} [A]	1.7	2.1	3.0	3.7	5.2	7.0
		I_{MAX} (60s) [A]	2.7	3.3	4.8	5.9	8.3	11.2
	Output power (400 V)	S_{INV} [KVA]	1.1	1.7	2.0	2.6	3.6	4.8
	Typical shaft output	$P_{M,N}$ [kW]	0.55	0.75	1.1	1.5	2.2	3.0
	Typical shaft output	$P_{M,N}$ [HP]	0.75	1.0	1.5	2.0	3.0	4.0
Max. cable cross section, motor	[mm ² /AWG] ¹⁾	4/10	4/10	4/10	4/10	4/10	4/10	4/10

	Input current (3 x 380-480 V)	$I_{L,N}$ [A]	1.6	1.9	2.6	3.2	4.7	6.1
		$I_{L,MAX}$ (60s)[A]	2.6	3.0	4.2	5.1	7.5	9.8
	Max. cable cross section, power	[mm ² /AWG] ¹⁾	4/10	4/10	4/10	4/10	4/10	4/10
	Max. pre-fuses	IEC/UL ²⁾ [A]	20/20	20/20	20/20	20/20	20/20	20/20
	Efficiency ³⁾	[%]	96	96	96	96	96	96
	Power loss at 100% load	[W]	28	38	55	75	110	150
	Weight	[kg]	2.1	2.1	2.1	2.1	3.7	3.7
Enclosure ⁴⁾	type	IP 20	IP 20	IP 20	IP 20	IP 20	IP 20	

According to international standards		Type	2840	2855	2875	2880	2881	2882
	Output current (3 x 380-480V)	I_{INV} [A]	9.1	12	16	24	32.0	37.5
		I_{MAX} (60s) [A]	14.5	19.2	25.6	38.4	51.2	60.0
	Output power (400 V)	S_{INV} [KVA]	6.3	8.3	11.1	16.6	22.2	26.0
	Typical shaft output	$P_{M,N}$ [kW]	4.0	5.5	7.5	11.0	15.0	18.5
	Typical shaft output	$P_{M,N}$ [HP]	5.0	7.5	10.0	15.0	20.0	25.0
Max. cable cross section, motor	[mm ² /AWG] ¹⁾	4/10	4/10	4/10	16/6	16/6	16/6	

	Input current (3 x 380-480 V)	$I_{L,N}$ [A]	8.1	10.6	14.9	24.0	32.0	37.5
		$I_{L,MAX}$ (60s)[A]	13.0	17.0	23.8	38.4	51.2	60
	Max. cable cross section, power	[mm ² /AWG] ¹⁾	4/10	4/10	4/10	16/6	16/6	16/6
	Max. pre-fuses	IEC/UL ²⁾ [A]	20/20	25/25	25/25	50/50	50/50	50/50
	Efficiency ³⁾	[%]	96	96	96	97	97	97
	Power loss at 100% load	[W]	200	275	372	412	562	693
	Weight	[kg]	3.7	6.0	6.0	18.5	18.5	18.5
Enclosure ⁴⁾	type	IP20	IP20	IP20	IP20/ NEMA 1	IP20/ NEMA 1	IP20/ NEMA 1	

1. American Wire Gauge. Max. cable cross section is the largest cable cross section that can be attached to the terminals. Always observe national and local regulations.

2. Type gG pre-fuses must be used for installation according to IEC rules. If you want to maintain UL/cUL you must use pre-fuses of the type Bussmann KTN-R 200 V, KTS-R 500 V or Ferraz Shawmut, type ATMR (max. 30A). The fuses must be placed for protection in a circuit that is capable of supplying a maximum of 100,000 amps RMS (symmetrical), 500 V maximum. See table under *Pre-fuses*.

3. Measured using a 25 m screened/armoured motor cable with a rated load and rated frequency.

4. IP20 is standard for VLT 2805-2875, whereas NEMA 1 is an option.

■ Available literature**■ Supplied with the unit**

Below is a list of the literature available for VLT 2800.
It must be noted that there may be deviations from one country to the next.

Supplied with the unit:

Instruction Manual	MG.27.AX.YY
--------------------	-------------

Various literature for VLT 2800:

Design Guide	MG.27.EX.YY
--------------	-------------

Data sheet	MD.27.AX.YY
------------	-------------

Instructions for VLT 2800:

LCP remote-mounting kit	MI.56.AX.51
-------------------------	-------------

Filter instruction	MI.28.B1.02
--------------------	-------------

VLT 2800 DeviceNet cable	MI.28.F1.02
--------------------------	-------------

Cold plate	MI.28.D1.02
------------	-------------

Precise stop	MI.28.C1.02
--------------	-------------

Communication with VLT 2800:

Profibus manual	MG.90.AX.YY
-----------------	-------------

VLT 2800 DeviceNet manual	MG.90.BX.YY
---------------------------	-------------

X = version number YY = language version

Parameter list with factory settings

PNU #	Parameterdescription	Factory setting	4-setup	Conv. index	Data type
001	Language	English	No	0	5
002	Local/remote operation	Remote-controlled	Yes	0	5
003	Local reference	000,000.000	Yes	-3	4
004	Active Setup	Setup 1	No	0	5
005	Programming Setup	Active Setup	No	0	5
006	Setup copying	No copying	No	0	5
007	LCP copy	No copying	No	0	5
008	Display scaling	1.00	Yes	-2	6
009	Large display readout	Frequency [Hz]	Yes	0	5
010	Small display line 1.1	Reference [%]	Yes	0	5
011	Small display line 1.2	Motor current [A]	Yes	0	5
012	Small display line 1.3	Power [kW]	Yes	0	5
013	Local control	Remote control as par. 100	Yes	0	5
014	Local stop/reset	Active	Yes	0	5
015	Local jog	Not active	Yes	0	5
016	Local reversing	Not active	Yes	0	5
017	Local reset of trip	Active	Yes	0	5
018	Data change lock	Not locked	Yes	0	5
019	Operating status at power up	Forced stop, use saved ref.	Yes	0	5
020	Lock for Hand mode	Active	No	0	5
024	User-defined Quick Menu	Not active	No	0	5
025	Quick Menu Setup	000	No	0	6

4-Setup:

'Yes' means that the parameter can be programmed individually in each of the four Setups, i.e. one single parameter can have four different data values. 'No' means that the data value will be the same in all Setups.

Conversion index:

This number refers to a conversion figure to be used when writing or reading via serial communication with a frequency converter.

See *Data character* in *Serial communication in the VLT 2800 Design Guide*.

Data type:

Data type shows the type and length of the telegram.

Data type	Description
3	Integer 16
4	Integer 32
5	Unsigned 8
6	Unsigned 16
7	Unsigned 32
9	Text string



VLT® 2800 Series

PNU #	Parameter-description	Factory setting	4-setup	Conv. index	Data-type
100	Configuration	Speed reg., open loop	Yes	0	5
101	Torque characteristics	Constant torque	Yes	0	5
102	Motor power $P_{M,N}$	depends on unit	Yes	1	6
103	Motor voltage $U_{M,N}$	depends on unit	Yes	-2	6
104	Motor frequency $f_{M,N}$	50 Hz	Yes	-1	6
105	Motor current $I_{M,N}$	depends on motor selected	Yes	-2	7
106	Rated motor speed	depends on par. 102	Yes	0	6
107	Automatic motor adjustment	Optimisation off	Yes	0	5
108	Stator resistance R_s	depends on motor selected	Yes	-3	7
109	Stator reactance X_s	depends on motor selected	Yes	-2	7
117	Resonance damping	OFF	Yes	0	6
119	High start torque	0.0 sec	Yes	-1	5
120	Start delay	0.0 sec	Yes	-1	5
121	Start function	Coast in start del.	Yes	0	5
122	Function at stop	Coast	Yes	0	5
123	Min. freq. for activation of par. 122	0.1 Hz	Yes	-1	5
126	DC braking time	10 sec.	Yes	-1	6
127	DC brake engaging frequency	OFF	Yes	-1	6
128	Thermal motor protection	No protection	Yes	0	5
130	Start frequency	0.0 Hz	Yes	-1	5
131	Voltage at start	0.0 V	Yes	-1	6
132	DC brake voltage	0%	Yes	0	5
133	Start voltage	depends on unit	Yes	-2	6
134	Load compensation	100 %	Yes	-1	6
135	U/f-ratio	depends on unit	Yes	-2	6
136	Slip compensation	100 %	Yes	-1	3
137	DC hold voltage	0%	Yes	0	5
138	Brake cut out value	3.0 Hz	Yes	-1	6
139	Brake cut in frequency	3.0 Hz	Yes	-1	6
140	Current, minimum value	0%	Yes	0	5
142	Leak reactance	depends on motor selected	Yes	-3	7
143	Internal ventilator control	Automatic	Yes	0	5
144	AC brake factor	1.30	Yes	-2	5
146	Reset voltage vector	Off	Yes	0	5

■ Factory Settings

PNU #	Parameter description	Factory setting	Changes during operation	4-setup	Conv. index	Data type
200	Output frequency range	Clockwise only, 0-132 Hz	No	Yes	0	5
201	Output frequency, low limit f_{MIN}	0.0 Hz	Yes	Yes	-1	6
202	Output frequency, high limit f_{MAX}	132 Hz	Yes	Yes	-1	6
203	Reference range	Min ref.-Max ref.	Yes	Yes	0	5
204	Minimum ref Ref_{MIN}	0.000 Hz	Yes	Yes	-3	4
205	Maximum ref Ref_{MAX}	50.000 Hz	Yes	Yes	-3	4
206	Ramp type	Linear	Yes	Yes	0	5
207	Ramp-up time 1	3.00 sec.	Yes	Yes	-2	7
208	Ramp-down time 1	3.00 sec.	Yes	Yes	-2	7
209	Ramp-up time 2	3.00 sec.	Yes	Yes	-2	7
210	Ramp-down time 2	3.00 sec.	Yes	Yes	-2	7
211	Jog ramp time	3.00 sec.	Yes	Yes	-2	7
212	Quick stop ramp-down time	3.00 sec.	Yes	Yes	-2	7
213	Jog frequency	10.0 Hz	Yes	Yes	-1	6
214	Reference function	Sum	Yes	Yes	0	5
215	Preset reference 1	0.00%	Yes	Yes	-2	3
216	Preset reference 2	0.00%	Yes	Yes	-2	3
217	Preset reference 3	0.00%	Yes	Yes	-2	3
218	Preset reference 4	0.00%	Yes	Yes	-2	3
219	Catch up/slow down reference	0.00%	Yes	Yes	-2	6
221	Current limit	160 %	Yes	Yes	-1	6
223	Warn. Low current	0.0 A	Yes	Yes	-1	6
224	Warn. High current	I_{MAX}	Yes	Yes	-1	6
225	Warn. Low frequency	0.0 Hz	Yes	Yes	-1	6
226	Warn. High frequency	132.0 Hz	Yes	Yes	-1	6
227	Warn. Low Feedback	-4000.000	Yes	Yes	-3	4
228	Warn. High Feedback	4000.000	Yes	Yes	-3	4
229	Frequency bypass, bandwidth	0 Hz (OFF)	Yes	Yes	0	6
230	Frequency bypass 1	0.0 Hz	Yes	Yes	-1	6
231	Frequency bypass 2	0.0 Hz	Yes	Yes	-1	6

VLT® 2800 Series

PNU #	Parameterdescription	Factory setting	4-setup	Conv. index	Data type
302	Digital input, term. 18	Start	Yes	0	5
303	Digital input, term. 19	Reversing	Yes	0	5
304	Digital input, term. 27	Reset and coast inverse	Yes	0	5
305	Digital input, term. 29	Jog	Yes	0	5
307	Digital input, term. 33	No function	Yes	0	5
308	Term. 53, analogue input voltage	Reference	Yes	0	5
309	Term. 53, min scaling	0.0 V	Yes	-1	6
310	Term. 53, max scaling	10.0 V	Yes	-1	6
314	Term. 60, analogue input current	No function	Yes	0	5
315	Term. 60, min scaling	0.0 mA	Yes	-4	6
316	Term. 60, max scaling	20.0 mA	Yes	-4	6
317	Time out	10 sec.	Yes	-1	5
318	Function after timeout	No function	Yes	0	5
319	Term. 42, analogue output	0-I _{MAX} = 0-20 mA	Yes	0	5
323	Relay output	Control ready	Yes	0	5
327	Pulse ref./FB	5000 Hz	Yes	0	7
341	Term. 46 digital output	Control ready	Yes	0	5
342	Term. 46 Max. pulse output	5000 Hz	Yes	0	6
343	Precise stop function	Normal ramp stop	Yes	0	5
344	Counter value	100000 pulses	Yes	0	7
349	Speed comp delay	10 ms	Yes	-3	6

4-Setup:

'Yes' means that the parameter can be programmed individually in each of the four Setups, i.e. one single parameter can have four different data values. 'No' means that the data value will be the same in all Setups.

Conversion index:

This number refers to a conversion figure to be used when writing or reading via serial communication with a frequency converter.

See *Data character* in *Serial communication in the VLT 2800 Design Guide*.

Data type:

Data type shows the type and length of the telegram.

Data type	Description
3	Integer 16
4	Integer 32
5	Unsigned 8
6	Unsigned 16
7	Unsigned 32
9	Text string



VLT® 2800 Series

PNU #	Parameter description	Factory setting	4-setup	Conv. index	Data type
400	Brake function	Depends on unit type	No	0	5
405	Reset function	Manual reset	Yes	0	5
406	Aut. restart time	5 sec.	Yes	0	5
409	Trip delay overcurrent	Off (61 sec.)	Yes	0	5
411	Switching frequency	4.5 kHz	Yes	0	6
412	Var. carrier frequency	No LC-filter	Yes	0	5
413	Overmodulation function	On	Yes	0	5
414	Min. feedback	0.000	Yes	-3	4
415	Max. feedback	1500.000	Yes	-3	4
416	Process units	No unit	Yes	0	5
417	Speed PID propor.ampl.	0.010	Yes	-3	6
418	Speed PID intergra.	100 ms	Yes	-5	7
419	Speed PID differentiation time	20.00 ms	Yes	-5	7
420	Speed PID diff. amplification limit	5.0	Yes	-1	6
421	Speed PID lowpass filter	20 ms	Yes	-3	6
423	U1 voltage	par. 103	Yes	-1	6
424	F1 frequency	Par. 104	Yes	-1	6
425	U2 voltage	par. 103	Yes	-1	6
426	F2 frequency	par. 104	Yes	-1	6
427	U3 voltage	par. 103	Yes	-1	6
428	F3 frequency	par. 104	Yes	-1	6
437	Proc. PID no/inv.	Normal	Yes	0	5
438	Proc. PID anti wind.	Active	Yes	0	5
439	Proc. PID start frequency	Par. 201	Yes	-1	6
440	Proc. PID start proportional ampl.	0.01	Yes	-2	6
441	Proc. PID integration time	Off (9999.99 s)	Yes	-2	7
442	Proc. PID differentiation time	Off (0.00 s).	Yes	-2	6
443	Proc. PID diff. ampl. limit	5.0	Yes	-1	6
444	Proc. PID lowpass filter time	0.02 s	Yes	-2	6
445	Flying start	Not possible	Yes	0	5
451	Speed PID feedforward factor	100%	Yes	0	6
452	Controller range	10 %	Yes	-1	6
456	Brake voltage reduce	0	Yes	0	5
461	Feedback conversion	Linear	Yes	0	5
462	Enhanced sleep mode timer	Off			
463	Boost setpoint	100%			
464	Wakeup pressure	0			
465	Minimum pump frequency	20			
466	Maximum pump frequency	50			
467	Minimum pump power	0 W			
468	Maximum pump power	0 W			
469	No flow power compensation	1.2			
470	Dry run time out	Off			
471	Dry run interlock timer	30 min.			
484	Initial ramp	Off			
485	Fill rate	Off			
486	Filled setpoint	Parameter 414			

VLT® 2800 Series

PNU #	Parameterdescription	Factory setting	4-setup	Conv. index	Data type
500	Address	1	No	0	5
501	Baudrate	9600 Baud	No	0	5
502	Coasting stop	Logic or	Yes	0	5
503	Quick stop	Logic or	Yes	0	5
504	DC brake	Logic or	Yes	0	5
505	Start	Logic or	Yes	0	5
506	Reversing	Logic or	Yes	0	5
507	Selection of Setup	Logic or	Yes	0	5
508	Selection of preset ref.	Logic or	Yes	0	5
509	Bus jog 1	10.0 Hz	Yes	-1	6
510	Bus jog 2	10.0 Hz	Yes	-1	6
512	Telegram profile	FC protocol	Yes	0	5
513	Bus time interval	1 sec.	Yes	0	5
514	Bus time interval function	Off	Yes	0	5
515	Data readout: Reference %		No	-1	3
516	Data readout: Reference [unit]		No	-3	4
517	Data readout: Feedback [unit]		No	-3	4
518	Data readout: Frequency		No	-1	3
519	Data readout: Frequency x scaling		No	-1	3
520	Data readout: Motor current		No	-2	7
521	Data readout: Torque		No	-1	3
522	Data readout: Power [kW]		No	1	7
523	Data readout: Power [HP]		No	-2	7
524	Data readout: Motor voltage [V]		No	-1	6
525	Data readout: DC Link voltage		No	0	6
526	Data readout: Motor thermal load		No	0	5
527	Data readout: Inverter thermal load		No	0	5
528	Data readout: Digital input		No	0	5
529	Data readout: Analogue input, term. 53		No	-1	5
531	Data readout: Analogue input, term. 60		No	-4	5
532	Data readout: Pulse reference		No	-1	7
533	Data readout: External reference		No	-1	6
534	Data readout: Status word		No	0	6
535	Data readout: Bus feedback 1		No	0	3
537	Data readout: Inverter temperature		No	0	5
538	Data readout: Alarm word		No	0	7
539	Data readout: Control word		No	0	6
540	Data readout: Warning word		No	0	7
541	Data readout: Extended status word		No	0	7
544	Data readout: Pulse count		No	0	7



VLT® 2800 Series

PNU #	Parameterdescription	Factory setting	4-setup	Conv. index	Data type
600	Operating hours		No	73	7
601	Hours run		No	73	7
602	kWh counter		No	2	7
603	Number of cut ins		No	0	6
604	Number of overtemperatures		No	0	6
605	Number of overvoltages		No	0	6
615	Fault log: Error code		No	0	5
616	Fault log: Time		No	0	7
617	Fault log: Value		No	0	3
618	Reset of kWh counter	No reset	No	0	7
619	Reset of running hours counter	No reset	No	0	5
620	Operation mode	Normal operation	No	0	5
621	Nameplate: Unit type		No	0	9
624	Nameplate: Software version		No	0	9
625	Nameplate: LCP identification no.		No	0	9
626	Nameplate: Database identification no.		No	-2	9
627	Nameplate: Power parts version		No	0	9
628	Nameplate: Application option type		No	0	9
630	Nameplate: Communication option type		No	0	9
632	Nameplate: BMC software identification		No	0	9
634	Nameplate: Unit identification for communication		No	0	9
635	Nameplate: Software parts no.		No	0	9
640	Software version		No	-2	6
641	BMC software identification		No	-2	6
642	Power card identification		No	-2	6
678	Configure control card				
700-	Used for wobble function, please see MI28J2xx				

4-Setup:

'Yes' means that the parameter can be programmed individually in each of the four Setups, i.e. one single parameter can have four different data values. No' means that the data value will be the same in all Setups.

Conversion index:

This number refers to a conversion figure to be used when writing or reading via serial communication with a frequency converter.

See *Data character* in *Serial communication* in the *VLT 2800 Design Guide*.

Data type:

Data type shows the type and length of the telegram.

Data type	Description
3	Integer 16
4	Integer 32
5	Unsigned 8
6	Unsigned 16
7	Unsigned 32
9	Text string



VLT® 2800 Series
