

Connection and operating instructions

Plug-in Display MBD 1000



In accordance with EN50081-1 and EN50082-2 for unrestricted use in housing and industrial areas

Introduction

The MBD 1000 is a microprocessor controlled plug-in display that can be universally applied to all MBS, AKS and MBT transmitters with a 4-20 mA output. The display provides a simple and effective solution for local monitoring of pressure and temperature. It does not require its own auxiliary voltage source but can be supplied directly from the measuring current.

The measuring value is displayed on a 4-digit LCD with the max. display area ranging from -1999 to +9999 digits.

The operating range of the display device can be directly adjusted to the transmitter range by simply entering the maximum and minimum measuring range limits as well as the decimal point position.

Parameters and limit values are entered via three keys which are accessible after removal of the cover.

All programmable parameters of the MBD 1000 are stored in an EEPROM; in the event of a current failure they will remain there for at least 10 years.

The MBD 1000 is equipped with a self-diagnosis system which continuously monitors the essential parts of the device.

Sensor operational performance is continuously monitored.

The MBD 1000 is tested and completely calibrated.

The MBD 1000 must be configured to the specific application.

Please refer to chapter "Configuration".

Safety advice

In order to exclude any risk whatsoever for the operator the following points have to be observed:

- Immediately switch off the unit in the event of visible damage or obvious malfunction.
- Always disconnect the MBD 1000 before opening it up. All electrical connections must be securely connected and touch-proof after installation.

- Standard regulations for operation and safety for electrical, light and heavy current equipment have to be observed, with particular attention having to be paid to national safety regulations (e.g. VDE 0100).



Attention: When running electric devices parts of these devices will always be highly energised. Unless the warnings are observed serious personal injuries or damage to property may result. Skilled personnel only should be allowed to work with this device. For trouble-free and safe operation of the device please ensure professional transport, storage, installation and connection as well as proper operation and maintenance.

MBD 1000 Connection and operating instructions

Electric connection

The MBD 1000 is simply plugged into a transmitter by means of a special adaptor for the cubic plug according to DIN43650.

Terminal assignment:

Use male plugs 1 and 2.

Supply voltage:

The display takes power directly from measuring current.

Electric connection and commissioning of the device must be carried out by trained and skilled personnel.

Wrong connection may lead to the destruction of the display device. Danfoss cannot assume any responsibility for this !!

Observe the maximum input current rating of 40mA under all circumstances !!

Assembly

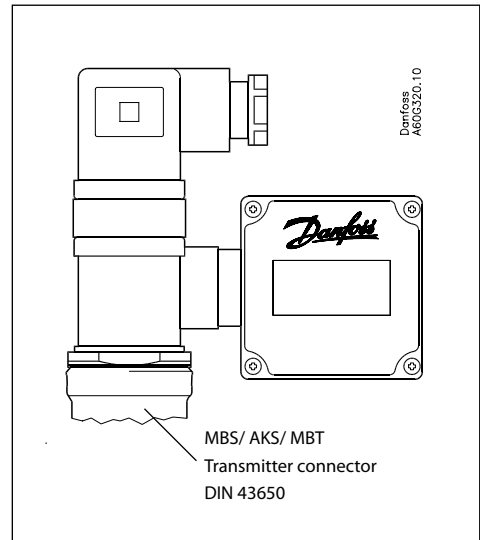
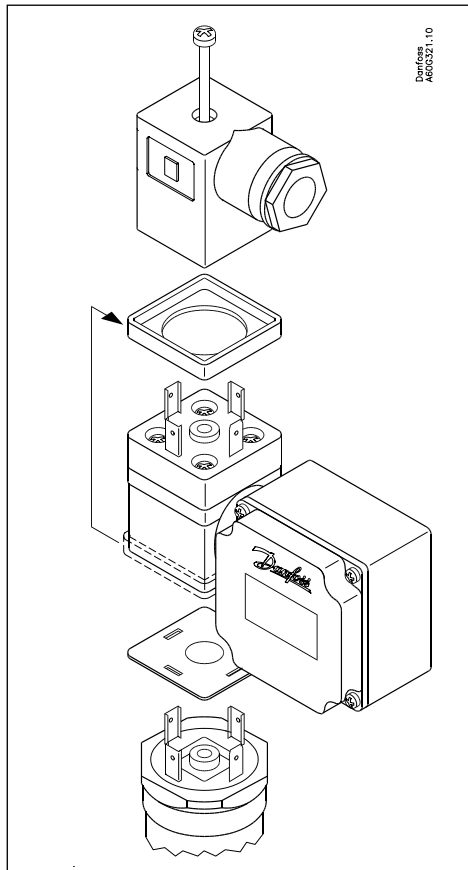

MBD 1000 Connection and operating instructions

Technical specification

Input signal	4 ... 20 mA (2-wire)
Max. allowed input current	40 mA
Reverse voltage protection	polarized installation
Voltage drop across display	approx. 3 V
Display	10 mm high LCD-display
Display range	starting and end value freely selectable
Maximum display value	9999 digits
Minimum display value	-1999 digits
Decimal point	any position
Measuring accuracy	0.2% ± 1 digit
Temperature drift	100 ppm / °C
Measuring interval	approx. 5 measurements / sec.
Filter	3 stages can be switched on
Nominal temperature	25°C
Ambient temperature	0 to 50°C
Relative atmospheric humidity	0 to 80% (non condensing)
Electromagnetic compatibility:	In accordance with EN50081-1 and EN50082-2
Additional error:	< 1%
Housing	ABS. Front screen made of polycarbonate. 48.5 x 48.5 x 35.5 mm (L x W x D)
Connection	pecially designed adaptor for cubic plug DIN43650 for simple connection. Length of screw has to be adjusted.
IP rating	front side IP65

Fault codes

In case of unacceptable conditions in the system a fault code will be displayed.

Fault codes have been defined as follows:

FE 1: Measuring range has been exceeded

This fault code indicates that the measuring range of the A/D converter has been exceeded.

Potential fault cause: transmitter damaged
short-circuit in transmitter connection
MBD 1000 not/incorrectly configured

Remedies: FE 1 will be reset as soon as the measuring values are back within their permissible range. Please check your transmitter and transmitter connecting cables.

FE 2: Measuring values have fallen below permissible range

This fault code indicates that the measuring values of the A/D converter have fallen below the permissible range.

Potential fault cause: transmitter damaged
transmitter connection interrupted
MBD 1000 not/incorrectly configured

Remedies: FE 2 will be reset as soon as the measuring values are back within their permissible range. Please check your transmitter and transmitter connecting cables.

MBD 1000 Connection and operating instructions

Configuration

Please note: measuring current should be at least 4 mA during configuration!

1. Press button 1, "dP" (decimal point) will be displayed.
Select decimal point position desired using buttons 2 and 3.
Acknowledge decimal point position by pressing button 1. "dP" will be displayed again.
2. Press button 1 once again, "An 4" (display for 4mA) will be displayed.
Use buttons 2 and 3 to set value to be displayed on the MBD 1000 for an input signal of 4mA.
Buttons 2 and 3 are equipped with a scrolling function, i.e. the value will be increased respectively decreased by 1 digit when button 2 respectively button 3 is pressed briefly (no more than 1 s). When pressing these buttons for a longer time (over 1 s) the values will start „scrolling“ upwards respectively downwards with the scrolling speed being increased after approx. 6s.
Acknowledge value displayed by pressing button 1. "An 4" will be displayed again.
3. Switch over to the next parameter by pressing button 1 once again. "An20" will be displayed (display for 20mA).
Use buttons 2 and 3 to set value to be displayed on the MBD 1000 for an input signal of 20mA.
Acknowledge value displayed by pressing button 1. "An20" will be displayed again.
4. Press button 1 once again. "LI" (limit) will be displayed.
Select measuring range limits desired using buttons 2 and 3.
0 = Values exceeding/falling below limits are acceptable. (FE1, FE2 displayed for hardware limits)
1 = Values exceeding/falling below limits are not acceptable. (FE1, FE2 displayed for area limits)

Acknowledge selection made by pressing button 1. "LI" will be displayed again. For pressure and temperature measuring transducers always enter "LI 0".

5. Press button 1 once again. "FILt" (filter) will be displayed.
Select input filter 0, 1, 2 or 3 desired using buttons 2 and 3.
0 = no filter
1 = filter 1 active
2 = filter 2 active
3 = filter 1 and filter 2 active

Filter 1: for filtering short pikes occurring when relays and contactors are switched. Make sure to always activate filter 1 if high loads are switched in the vicinity of the MBD 1000 (wires or sensor or if large spikes are to be expected).
Additional display delay: approx. 0.5s

Filter 2: prevents "jumping" of the last figure, a phenomenon often found with digital displays and controllers. Make sure to always activate filter 2 if the display range exceeds 2000 digits.
Additional display delay: approx. 1s

Acknowledge selection made by pressing button 1. "FILt" will be displayed again.

The adjustment of the MBD 1000 to the transmitter is now completed. The MBD 1000 can be immediately switched over to display the current measuring value by pressing button 1.

