

A. Failure to read and follow all instruction carefully before installing or operating this flow switch could cause personal injury and/or property damage. Save these instructions for future use.

B. NOTE FOR SAFETY

Warning

- Never remove the cover when power is applied. This can result in electric shock.
- Connect wiring after turning off power. This can result in electric shock.
- Do not sprinkle water over the microswitch. This can result in electric shock.
- Do not connect a load exceeding the electric rating. This can result in bad contacts.
- Do not turn screws other than the operating value setting screw. Incorrect operations or water leakage can occur.
- Install the switch so that the arrow indication and the fluid flow match. The switch does not work if fluid flows in the opposite direction. In addition, paddles can be damaged.
- Use fluid that does not corrode the liquid contacting material. In addition, use fluid in liquid form. Gas or liquid mixed with gas causes unstable operations.
- Connect the switch to ground. Do not connect the grounding wire to a gas pipe, water pipe, lightning rod or the grounding wire of a telephone line. If the grounding is not appropriate, this can result in electric shock.
- Use fluid with flow velocity of 2m/s or less. In addition, avoid strong pulsating fluid and vibration. Paddle can be damaged.

C. DESCRIPTION

Type FQS Flow Switch with SPDT micro switch detects the fluid flow in pipe line. The electric contact block is completely sealed from the fluid in the pipe line by a bellows. When a flow rate increases, the actuating plate will move while the resistant force ordering.

D. SPECIFICATIONS

- Structure Open
- Liquid contacting material Copper alloy or stainless paddle (option)
- Maximum operating pressure 0.98 MPa
- Allowable fluid temperature 5 to 80 °C
- Endurance operations 100,000 operations
- Mounting screw R1 (MPT) or NPT (option)
- Ambient temperature -25 to +80 °C
- Ambient humidity 80 %RH or less (No freezing, no condensation)
- Contact structure Single-pole double-throw

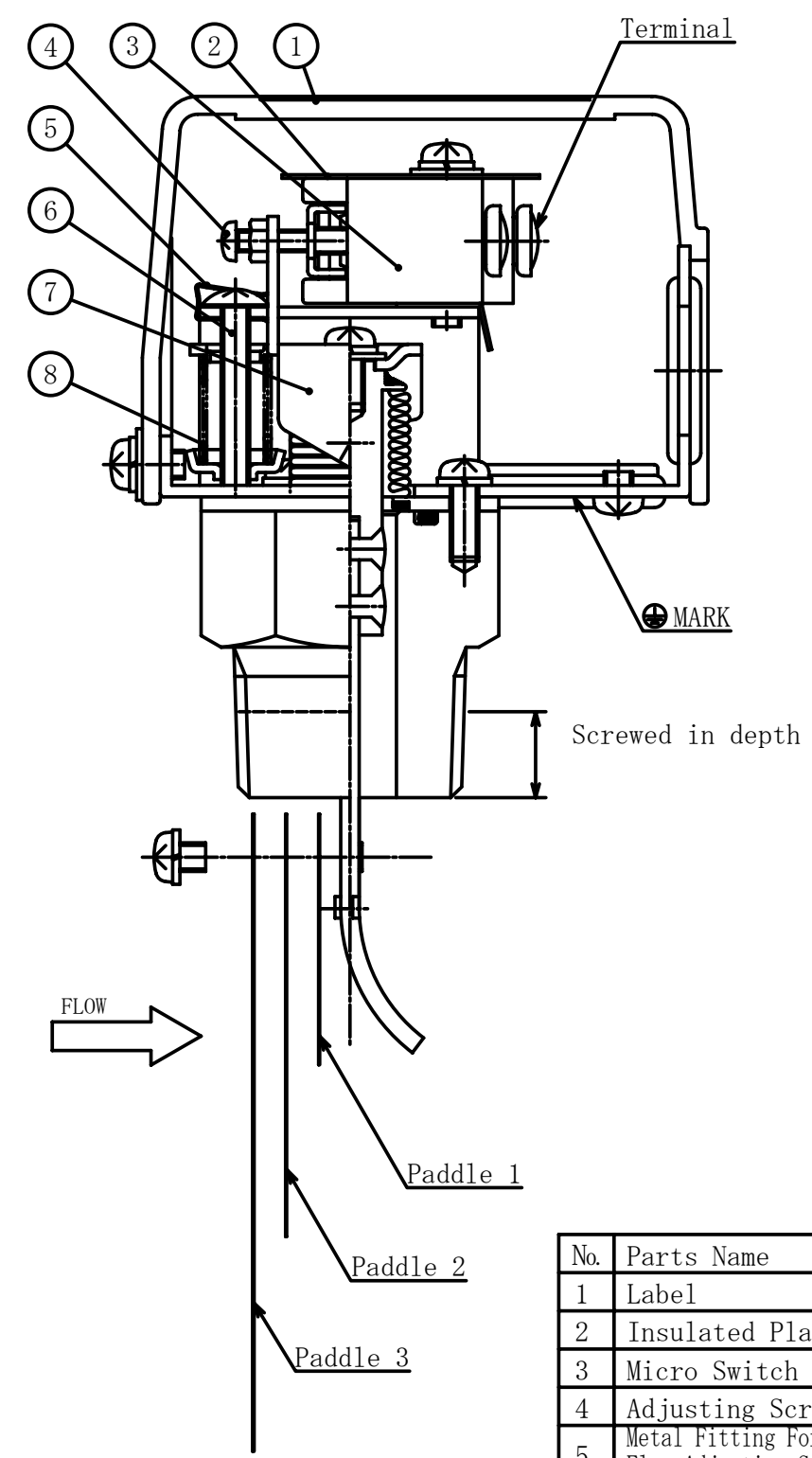
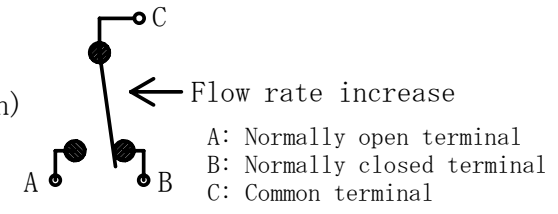

Unit: A

Type name, symbol	Voltage	Resistive load	Lamp load	Motor load
Standard (G)	125V AC	15	1.5	5
	250V AC	15	1.25	3
	30V DC	6	1.5	5
	125V DC	0.5	0.5	0.05
DC high load type (D)	125V DC	10	1.5	5
	250V DC	3	1.5	2

Type name, symbol	Voltage	Minimum applicable load	Maximum current load
Small load type (K)	24V DC	0.01	0.1
	100V AC	0.01	0.1

No.	Parts Name	Q' ty.
1	Label	1
2	Insulated Plate	1
3	Micro Switch	1
4	Adjusting Screw	1
5	Metal Fitting For Flow Adjusting Screw	1
6	Flow Adjusting Screw	1
7	Actuating Plate	1
8	Adjusting Spring	1

D. INSTALLATION METHOD

- Provide a straight pipe section of more than 5 times the piping diameter in front and back of the flow switch. This is used to prevent hunting due to turbulent flow.
- Basically install the switch in horizontal piping with the cover facing upward but it can be installed in vertical piping.
However, in the case of a vertical pipe installation, the operating value may change about 20% compared to the horizontal pipe installation.
- For piping of the flow switch, use a commercially available Tee joint (conforming to JIS B 2301).
If the available Tee joint cannot be installed, adjust the dimension "a" in the diagram on the right to that of the Tee joint of JIS.
- When installing the flow switch to piping, the depth of the flow switch screwed in shall be 12 ± 1.2 mm.
- For wiring, follow the instructions written on the insulation plate of the microswitch.

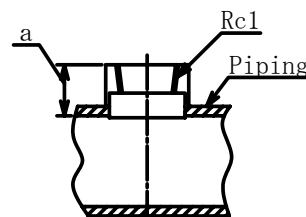

E. OPERATING VALUE SETTING

- When the operating value is not specified, the flow switch is shipped with the operating value set around the minimum flow rate.
- When you turn the flow adjusting screw ⑥ clockwise, the operating point goes up. When you turn it counterclockwise, the operating point goes down.
But if you turn the screw counterclockwise too much, the operation becomes unstable and if you turn it further, the setting screw breaks off.
- If you have changed the setting value, make sure to operate the paddles and check the operation of the microswitch.
- Never remove the metal fitting ⑤ because this is used to prevent the flow adjusting screw ⑥ from loosening.
- The adjusting screw ④ is exclusively used by our service personnel.
Do not use this screw for adjustment.
- When setting the operating value, refer to either decreasing flow setting value or increasing flow setting value.

F. OPERATION ADJUSTMENT RANGE TABLE

Unit: L/min

Piping	Paddle combination	Adjustment range		flow velocity of 2m/s
		MIN	MAX	
25A (1B)	1	18	45	72
32A (1 1/4 B)	1	43	100	120
40A (1 1/2 B)	1	63	135	163
50A (2B)	1+2	50	150	264
	1	151	220	
65A (2 1/2 B)	1+2	105	355	432
	1	356	360	
80A (3B)	1+2+3	100	225	612
	1+2	226	480	
	1	481	510	
100A (4B)	1+2+3	200	385	1044
	1+2	386	820	
	1	821	870	
125A (5B)	1+2+3	350	594	1613
	1+2	595	1265	
	1	1266	1342	
150A (6B)	1+2+3	530	836	2268
	1+2	837	1780	
	1	1781	1890	

- This table is based on the operating point for decreasing flow.
Decreasing flow setting value means the flow switch operates when the flow rate decreases. Increasing flow setting value means the flow switch operates when the flow rate increases.
- Differential value (difference between the decreasing flow operating value and the increasing flow operating value) is not determined specifically. The guideline value is as follows:

Less than 50L/min:	About 10L/min
From 50L/min to less than 100L/min:	About 15L/min
100L/min or more:	About 20% of the setting value
- This table is based on the condition when the depth screwed in is kept within 12 ± 1.2 mm. Tee joint of JIS.
- Paddle size is in the following order: 1<2<3
flow switch screwed in shall be 12 ± 1.2 mm.
- When the setting value is not specified, the attached paddle 1 can be used for 40A or less, 1+2 for 65A or less and 1+2+3 for 80A or more.
- When more than two paddles is attached, you can change the flow rate adjustment range by removing the paddles one by one in order of the longer paddle first.
- To install the paddles, install the paddle 1 first then stack the paddle 2 and then the paddle 3.

G. OPERATION CHECK

Install and calibrate the Product correctly and then check its operation to confirm correct function of the whole system when using.

H. LIMIT ON APPLICATION

The product is not designed nor manufactured for an use in such equipment or system that is intended to be used under such circumstances that may affect human life. For application requiring extreme high reliability, please contact the Company first.

I. SCOPE OF WARRANTY

Unless otherwise agreed by the parties, warranty period of the Product shall be one year after date of delivery to Buyer. In case of failure attributable to the Company within such period, the Product shall be repaired or replaced without charge, provided that any one of followings are out of the warranty :

- ① Improper handling or application by user.
- ② Modification or repair by other than the Company.
- ③ Any failure to be caused by acts of God, fire, storm or the like, war, riot or the like and other causes beyond the control of the Company.

Warranty described in this paragraph means the warranty for the Product itself and does not include warranty for any consequential damage arising out of or occasioned by a defect or failure of the Product.