

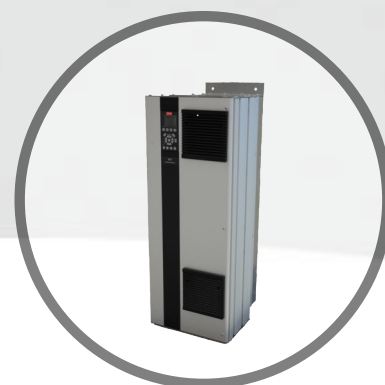

Instruction Manual

VLT[®] AutomationDrive FC 302

90–315 kW D-Frame



Contents

1 Introduction	3
1.1 Purpose of the Manual	3
1.2 Additional Resources	3
1.3 Document and Software Version	3
1.4 Product Overview	3
1.5 Approvals and Certifications	7
1.6 Disposal	7
2 Safety	8
2.1 Safety Symbols	8
2.2 Qualified Personnel	8
2.3 Safety Precautions	8
3 Mechanical Installation	10
3.1 Unpacking	10
3.2 Installation Environments	10
3.3 Mounting	10
4 Electrical Installation	12
4.1 Safety Instructions	12
4.2 EMC-compliant Installation	12
4.3 Grounding	12
4.4 Wiring Schematic	14
4.5 Access	15
4.6 Motor Connection	15
4.7 AC Line Input Connection	31
4.8 Control Wiring	31
4.8.1 Control Terminal Types	31
4.8.2 Wiring to Control Terminals	33
4.8.3 Enabling Motor Operation (Terminal 27)	33
4.8.4 Voltage/Current Input Selection (Switches)	33
4.8.5 Safe Torque Off (STO)	34
4.8.6 RS485 Serial Communication	34
4.9 Installation Check List	35
5 Commissioning	36
5.1 Safety Instructions	36
5.2 Applying Power	36
5.3 Local Control Panel Operation	36

5.4 Basic Programming	39
5.4.1 Commissioning via [Main Menu]	39
5.5 Checking Motor Rotation	40
5.6 Local Control Test	40
5.7 System Start-up	40
6 Application Set-up Examples	41
6.1 Introduction	41
6.2 Application Examples	41
7 Maintenance, Diagnostics and Troubleshooting	48
7.1 Maintenance and Service	48
7.2 Heatsink Access Panel	48
7.3 Status Messages	48
7.4 Warning and Alarm Types	51
7.5 List of Warnings and Alarms	51
7.6 Troubleshooting	59
8 Specifications	62
8.1 Electrical Data	62
8.1.1 Line Power Supply 3x380–500 V AC	62
8.1.2 Line Power Supply 3x525–690 V AC	63
8.2 Line Power Supply	65
8.3 Motor Output and Motor Data	65
8.4 Ambient Conditions	65
8.5 Cable Specifications	66
8.6 Control Input/Output and Control Data	66
8.7 Fuses	69
8.8 Connection Tightening Torques	71
8.9 Power Ratings, Weight and Dimensions	71
9 Appendix	73
9.1 Symbols, Abbreviations, and Conventions	73
9.2 Parameter Menu Structure	73
Index	79

1 Introduction

1.1 Purpose of the Manual

This instruction manual provides information for safe installation and commissioning of the adjustable frequency drive.

This instruction manual is intended for use by qualified personnel.

Read and follow the instruction manual to use the adjustable frequency drive safely and professionally, and pay particular attention to the safety instructions and general warnings. Keep this instruction manual available with the adjustable frequency drive at all times.

VLT® is a registered trademark.

1.2 Additional Resources

Other resources are available to understand advanced adjustable frequency drive functions and programming.

- The VLT® AutomationDrive FC 302 *Programming Guide* provides greater detail on working with parameters and many application examples.
- The VLT® AutomationDrive FC 302 *Design Guide* provides detailed information about capabilities and functionality to design motor control systems.
- Instructions for operation with optional equipment.

Supplementary publications and manuals are available from Danfoss. See vlt-drives.danfoss.com/Support/Technical-Documentation/ for listings.

1.3 Document and Software Version

This manual is regularly reviewed and updated. All suggestions for improvement are welcome. *Table 1.1* shows the document version and the corresponding software version.

Edition	Remarks	Software version
MG34U4xx	Replaces MG34U3xx	7.42

Table 1.1 Document and Software Version

1.4 Product Overview

1.4.1 Intended Use

The adjustable frequency drive is an electronic motor controller intended for:

- Regulation of motor speed in response to system feedback or to remote commands from external controllers. A power drive system consists of the adjustable frequency drive, the motor, and equipment driven by the motor.
- System and motor status surveillance.

The adjustable frequency drive can also be used for motor protection.

Depending on the configuration, the adjustable frequency drive can be used in stand-alone applications or form part of a larger appliance or installation.

The adjustable frequency drive is allowed for use in residential, industrial and commercial environments in accordance with local laws and standards.

NOTICE!

In a residential environment, this product can cause radio interference, in which case supplementary mitigation measures can be required.

Foreseeable misuse

Do not use the adjustable frequency drive in applications which are non-compliant with specified operating conditions and environments. Ensure compliance with the conditions specified in *chapter 8 Specifications*.

1.4.2 Interior Views

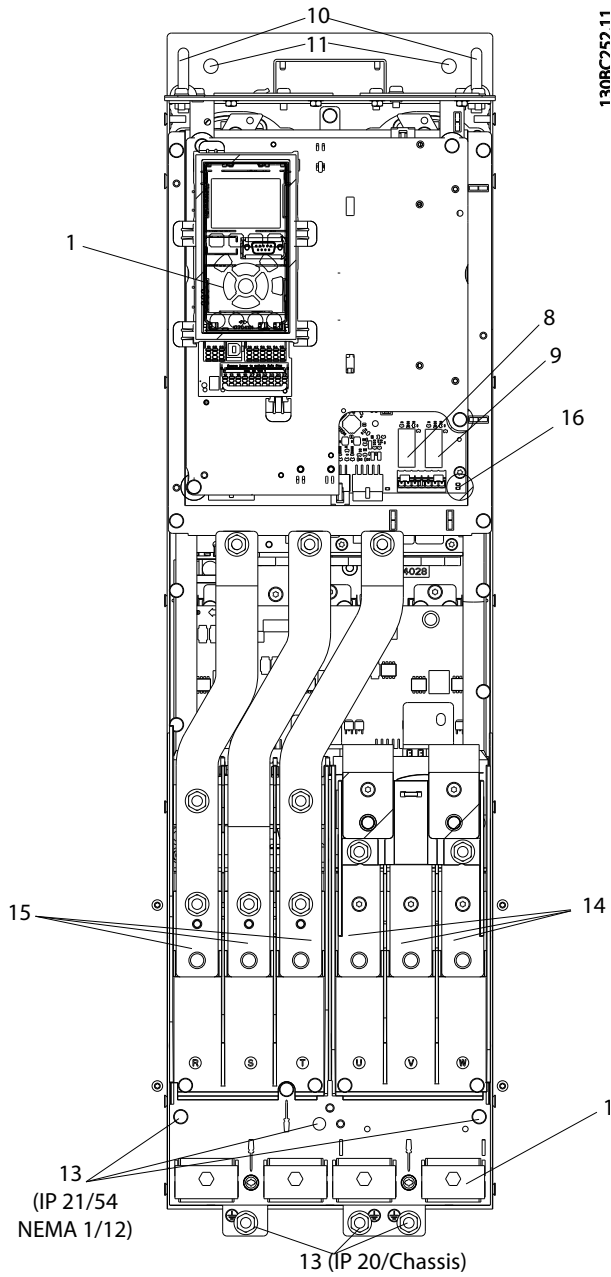
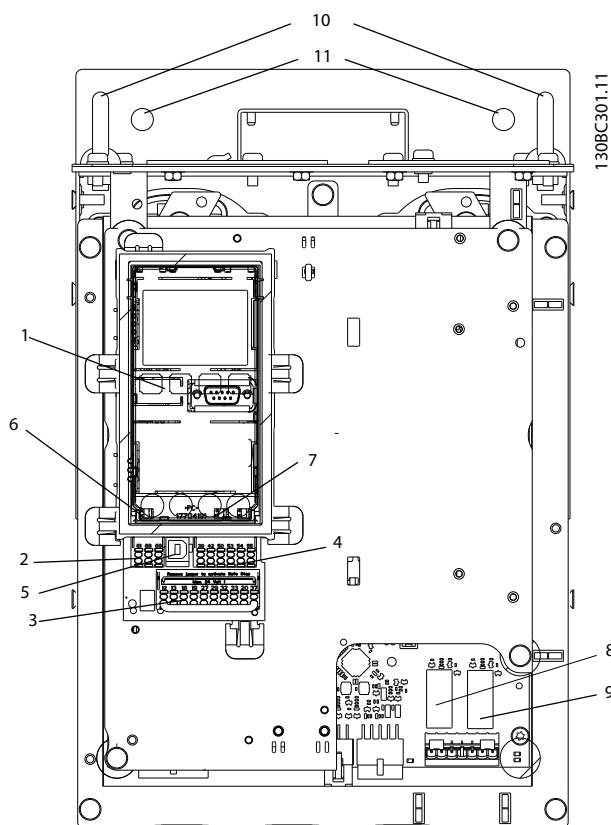

Figure 1.1 D1 Interior Components



1	LCP (local control panel)	9	Relay 2 (04, 05, 06)
2	RS485 serial bus connector	10	Lifting ring
3	Digital I/O and 24 V power supply	11	Mounting holes
4	Analog I/O connector	12	Cable clamp (PE)
5	USB connector	13	Ground
6	Serial bus terminal switch	14	Motor output terminals 96 (U), 97 (V), 98 (W)
7	Analog switches (A53), (A54)	15	Line power input terminals 91 (L1), 92 (L2), 93 (L3)
8	Relay 1 (01, 02, 03)	16	TB5 (IP21/54 only). Terminal block for anti-condensation heater

Figure 1.2 Close-up View: LCP and Control Functions

NOTICE!

For location of TB6 (terminal block for contactor), see chapter 4.6 Motor Connection.

1.4.3 Extended Options Cabinets

If an adjustable frequency drive is ordered with one of the following options, it is supplied with an options cabinet that makes it taller.

- Brake chopper
- Line power disconnect
- Contactor

- Line power disconnect with contactor
- Circuit breaker
- Oversized wiring cabinet
- Regeneration terminals
- Load share terminals

Figure 1.3 shows an example of an adjustable frequency drive with an options cabinet. Table 1.2 lists the variants for the adjustable frequency drives that include input options.

Options unit designations	Extension cabinets	Possible options
D5h	D1h enclosure with short extension.	<ul style="list-style-type: none"> • Brake. • Disconnect.
D6h	D1h enclosure with tall extension.	<ul style="list-style-type: none"> • Contactor. • Contactor with disconnect. • Circuit breaker.
D7h	D2h enclosure with short extension.	<ul style="list-style-type: none"> • Brake. • Disconnect.
D8h	D2h enclosure with tall extension.	<ul style="list-style-type: none"> • Contactor. • Contactor with disconnect. • Circuit breaker.

Table 1.2 Overview of Extended Options

The D7h and D8h adjustable frequency drives (D2h plus options cabinet), include an approx. 200 mm (8 in) pedestal for floor mounting.

There is a safety latch on the front cover of the options cabinet. If the adjustable frequency drive is supplied with a line power disconnect or circuit breaker, the safety latch prevents the cabinet door from being opened while the adjustable frequency drive is energized. Before opening the door of the adjustable frequency drive, open the disconnect or circuit breaker (to de-energize the adjustable frequency drive) and remove the cover of the options cabinet.

For adjustable frequency drives purchased with a disconnect, contactor or circuit breaker, the nameplate label includes a type code for a replacement that does not include the option. If there is a problem with the adjustable frequency drive, it is replaced independently of the options.

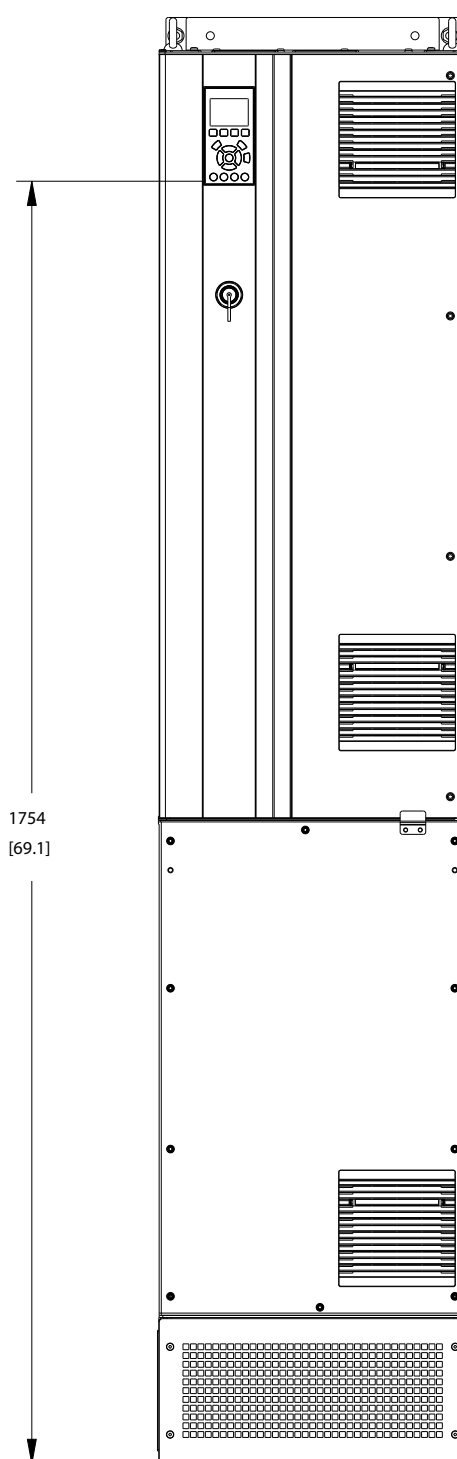
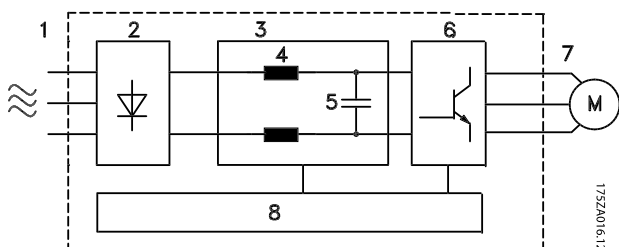

Figure 1.3 D7h enclosure

1.4.4 Block Diagram of the Adjustable Frequency Drive

Figure 1.4 is a block diagram of the internal components of the adjustable frequency drive.



Area	Title	Functions
1	Line power input	<ul style="list-style-type: none"> 3-phase AC line power supply to the adjustable frequency drive.
2	Rectifier	<ul style="list-style-type: none"> The rectifier bridge converts the AC input to DC current to supply inverter power.
3	DC bus	<ul style="list-style-type: none"> Intermediate DC bus circuit handles the DC current.
4	DC reactors	<ul style="list-style-type: none"> Filter the intermediate DC circuit voltage. Provide line transient protection. Reduce RMS current. Raise the power factor reflected back to the line. Reduce harmonics on the AC input.
5	Capacitor bank	<ul style="list-style-type: none"> Stores the DC power. Provides ride-through protection for short power losses.
6	Inverter	<ul style="list-style-type: none"> Converts the DC into a controlled PWM AC waveform for a controlled variable output to the motor.
7	Output to motor	<ul style="list-style-type: none"> Regulated 3-phase output power to the motor.

Area	Title	Functions
8	Control circuitry	<ul style="list-style-type: none"> Input power, internal processing, output, and motor current are monitored to provide efficient operation and control. User interface and external commands are monitored and performed. Status output and control can be provided.

Table 1.3 Legend to Figure 1.4

Figure 1.4 Block Diagram of the Adjustable Frequency Drive

1.4.5 Enclosure Types and Power Ratings

For enclosure types and power ratings of the adjustable frequency drives, refer to *chapter 8.9 Power Ratings, Weight and Dimensions*.

1.5 Approvals and Certifications

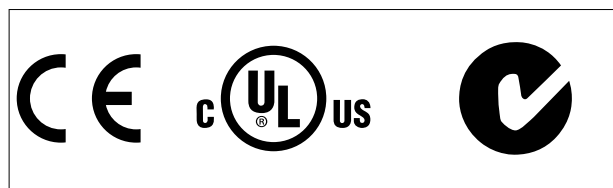

More approvals and certifications are available. Contact the local Danfoss partner. Adjustable frequency drives of enclosure type T7 (525–690 V) are UL-certified for only 525–600 V.

The adjustable frequency drive complies with UL 508C thermal memory retention requirements. For more information, refer to the section *Motor Thermal Protection* in the product-specific *Design Guide*.

1.6 Disposal

Do not dispose of equipment containing electrical components together with domestic waste. Collect it separately in accordance with local and currently valid legislation.

2 Safety

2.1 Safety Symbols

The following symbols are used in this manual:

⚠ WARNING

Indicates a potentially hazardous situation that could result in death or serious injury.

⚠ CAUTION

Indicates a potentially hazardous situation that could result in minor or moderate injury. It can also be used to alert against unsafe practices.

NOTICE

Indicates important information, including situations that can result in damage to equipment or property.

2.2 Qualified Personnel

Correct and reliable transport, storage, installation, operation, and maintenance are required for the trouble-free and safe operation of the adjustable frequency drive. Only qualified personnel are allowed to install and operate this equipment.

Qualified personnel are defined as trained staff who are authorized to install, commission, and maintain equipment, systems, and circuits in accordance with pertinent laws and regulations. Additionally, the qualified personnel must be familiar with the instructions and safety measures described in this instruction manual.

2.3 Safety Precautions

⚠ WARNING

HIGH VOLTAGE

Adjustable frequency drives contain high voltage when connected to AC line power input, DC supply, or load sharing. Failure to perform installation, start-up, and maintenance by qualified personnel can result in death or serious injury.

- Only qualified personnel may perform installation, start-up, and maintenance.

⚠ WARNING

UNINTENDED START

When the adjustable frequency drive is connected to AC line power, DC supply, or load sharing, the motor may start at any time. Unintended start during programming, service, or repair work can result in death, serious injury, or property damage. The motor can start via an external switch, a serial bus command, an input reference signal from the LCP, or after a cleared fault condition.

To prevent unintended motor start:

- Disconnect the adjustable frequency drive from line power.
- Press [Off/Reset] on the LCP before programming parameters.
- Completely wire and assemble the adjustable frequency drive, motor, and any driven equipment before connecting the adjustable frequency drive to AC line power, DC supply, or load sharing.

⚠ WARNING

DISCHARGE TIME

The adjustable frequency drive contains DC link capacitors that can remain charged even when the adjustable frequency drive is not powered. Failure to wait the specified time after power has been removed before performing service or repair work could result in death or serious injury.

1. Stop the motor.
2. Disconnect AC line power, permanent magnet type motors, and remote DC link power supplies, including battery backups, UPS, and DC link connections to other adjustable frequency drives.
3. Wait for the capacitors to discharge fully before performing any service or repair work. The duration of waiting time is specified in *Table 2.1*.

Voltage [V]	Power range [kW (hp)]	Minimum waiting time (minutes)
3x400	90–250 (125–350)	20
3x400	110–315 (150–425)	20
3x500	110–315 (150–425)	20
3x500	132–355 (175–475)	20
3x525	55–250 (75–350)	20
3x525	90–315 (125–425)	20
3x690	55–250 (75–350)	20
3x690	110–315 (150–425)	20

Table 2.1 Discharge Time

⚠ WARNING

LEAKAGE CURRENT HAZARD

Leakage currents exceed 3.5 mA. Failure to ground the adjustable frequency drive properly can result in death or serious injury.

- Ensure the correct grounding of the equipment by a certified electrical installer.

⚠ WARNING

EQUIPMENT HAZARD

Contact with rotating shafts and electrical equipment can result in death or serious injury.

- Ensure that only trained and qualified personnel perform installation, start-up, and maintenance.
- Ensure that electrical work conforms to national and local electrical codes.
- Follow the procedures in this manual.

⚠ WARNING

UNINTENDED MOTOR ROTATION

WINDMILLING

Unintended rotation of permanent magnet motors creates voltage and can charge the unit, resulting in death, serious injury, or equipment damage.

- Ensure that permanent magnet motors are blocked to prevent unintended rotation.

⚠ CAUTION

INTERNAL FAILURE HAZARD

An internal failure in the adjustable frequency drive can result in serious injury when the adjustable frequency drive is not properly closed.

- Ensure that all safety covers are in place and securely fastened before applying power.

3 Mechanical Installation

3

3.1 Unpacking

3.1.1 Items Supplied

Items supplied may vary according to product configuration.

- Make sure the items supplied and the information on the nameplate correspond to the order confirmation.
- Check the packaging and the adjustable frequency drive visually for damage caused by inappropriate handling during shipment. File any claim for damage with the carrier. Retain damaged parts for clarification.

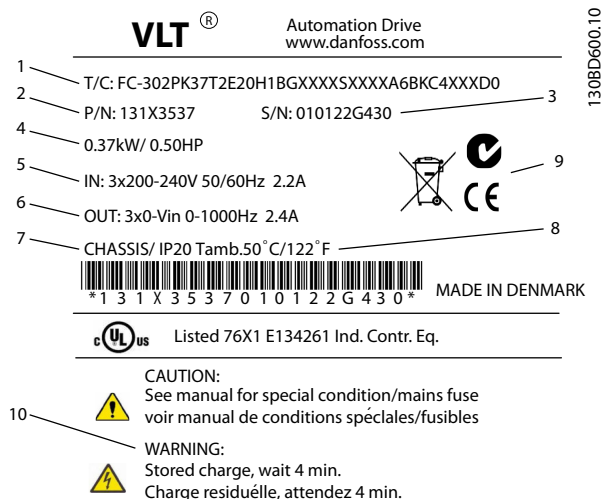

1	Type code
2	Order number
3	Serial number
4	Power rating
5	Input voltage, frequency and current (at low/high voltages)
6	Output voltage, frequency and current (at low/high voltages)
7	Enclosure type and IP protection rating
8	Maximum ambient temperature
9	Certifications
10	Discharge time (Warning)

Figure 3.1 Product Nameplate (Example)

NOTICE!

Do not remove the nameplate from the adjustable frequency drive (loss of warranty).

3.1.2 Storage

Ensure that the requirements for storage are fulfilled. Refer to *chapter 8.4 Ambient Conditions* for further details.

3.2 Installation Environments

NOTICE!

In environments with airborne liquids, particles, or corrosive gases, ensure that the IP/type rating of the equipment matches the installation environment. Failure to meet requirements for ambient conditions can reduce the lifetime of the adjustable frequency drive. Ensure that requirements for air humidity, temperature, and altitude are met.

Voltage [V]	Altitude restrictions
380–500	At altitudes above 3000 m (10,000 ft), contact Danfoss regarding PELV
525–690	At altitudes above 2000 m (6,600 ft), contact Danfoss regarding PELV

Table 3.1 Installation in High Altitudes

For detailed ambient conditions specifications, refer to *chapter 8.4 Ambient Conditions*.

3.3 Mounting

NOTICE!

Improper mounting can result in overheating and reduced performance.

Cooling

- Ensure that top and bottom clearance for air cooling is provided. Clearance requirement: 225 mm (9 in).
- Consider derating for temperatures starting between 45 °C (113 °F) and 50 °C (122 °F) and elevation 1000 m (3,300 ft) above sea level. See the adjustable frequency drive design guide for detailed information.

The adjustable frequency drive utilizes a backchannel cooling concept that removes heatsink cooling air. The heatsink cooling air carries approximately 90% of the heat out of the backchannel of the adjustable frequency drive.

Redirect the backchannel air from the panel or room by using:

- Duct cooling. A backchannel cooling kit is available to direct the heatsink cooling air out of the panel when an IP20/chassis adjustable frequency drive is installed in a Rittal enclosure. Use of this kit reduces the heat in the panel and smaller door fans can be specified on the enclosure.
- Cooling out the back (top and bottom covers). The backchannel cooling air can be ventilated out of the room so that the heat from the backchannel is not dissipated into the control room.

NOTICE!

A door fan(s) is required on the enclosure to remove the heat not contained in the backchannel of the adjustable frequency drive. It also removes any additional losses generated by other components inside the adjustable frequency drive. Calculate the total required air flow so that the appropriate fan(s) can be selected.

Secure the necessary airflow over the heatsink. The flow rate is shown in *Table 3.2*.

Frame	Door fan/top fan	Heatsink fan
D1h/D3h/D5h/D6h	102 m ³ /hr (60 CFM)	420 m ³ /hr (250 CFM)
D2h/D4h/D7h/D8h	204 m ³ /hr (120 CFM)	840 m ³ /hr (500 CFM)

Table 3.2 Airflow

Lifting

Always lift the adjustable frequency drive using the dedicated lifting eyes. Use a bar to avoid bending the lifting holes.

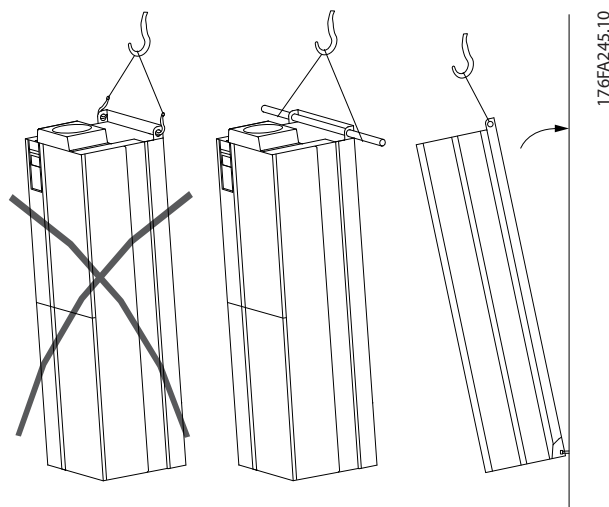

Figure 3.2 Recommended Lifting Method

WARNING

RISK OF INJURY OR DEATH

The lifting bar must be able to handle the weight of the adjustable frequency drive to ensure that it does not break during lifting.

- See *chapter 8.9 Power Ratings, Weight and Dimensions* for the weight of the different enclosure types.
- Maximum diameter for bar: 2.5 cm (1 inch).
- The angle from the top of the adjustable frequency drive to the lifting cable: 60° or greater.

Failure to follow recommendations could result in death or serious injury.

Mounting

1. Ensure that the strength of the mounting location supports the unit weight.
2. Place the unit as near to the motor as possible. Keep the motor cables as short as possible.
3. Mount the unit vertically to a solid flat surface to provide cooling airflow. Ensure free space for cooling.
4. Ensure the access to open the door.
5. Ensure the cable entry from the bottom.

4 Electrical Installation

4

4.1 Safety Instructions

See *chapter 2 Safety* for general safety instructions.

⚠ WARNING

INDUCED VOLTAGE

Induced voltage from output motor cables that run together can charge equipment capacitors even with the equipment turned off and locked out. Failure to run output motor cables separately or use shielded cables or metal conduits could result in death or serious injury.

- run output motor cables separately, or
- use shielded cables or metal conduits

⚠ CAUTION

SHOCK HAZARD

The adjustable frequency drive can cause a DC current in the PE conductor. Failure to follow the recommendation below means the RCD may not provide the intended protection.

- When a residual current-operated protective device (RCD) is used for protection against electrical shock, only an RCD of Type B is permitted on the supply side.

NOTICE!

The adjustable frequency drive is supplied with Class 20 motor overload protection.

Overcurrent protection

- Additional protective equipment, such as short-circuit protection or motor thermal protection between adjustable frequency drive and motor, is required for applications with multiple motors.
- Input fusing is required to provide short circuit and overcurrent protection. If not factory-supplied, the installer must provide the fuses. See maximum fuse ratings in *chapter 8.7 Fuses*.

Wire type and ratings

- All wiring must comply with local and national regulations regarding cross-section and ambient temperature requirements.
- Power connection wire recommendation: Minimum 75 °C (167 °F)-rated copper wire.

See *chapter 8.1 Electrical Data* and *chapter 8.5 Cable Specifications* for recommended wire sizes and types.

4.2 EMC-compliant Installation

To obtain an EMC-compliant installation, follow the instructions provided in

- *Chapter 4.3 Grounding.*
- *Chapter 4.4 Wiring Schematic.*
- *Chapter 4.6 Motor Connection.*
- *Chapter 4.8 Control Wiring.*

4.3 Grounding

⚠ WARNING

LEAKAGE CURRENT HAZARD

Leakage currents exceed 3.5 mA. Failure to ground the adjustable frequency drive properly could result in death or serious injury.

- Ensure the correct grounding of the equipment by a certified electrical installer.

For electrical safety

- Ground the adjustable frequency drive in accordance with applicable standards and directives.
- Use a dedicated ground wire for input power, motor power, and control wiring.
- Do not ground one adjustable frequency drive to another in a "daisy chain" fashion.
- Keep the ground wire connections as short as possible.
- Follow the motor manufacturer wiring requirements.
- Minimum cable cross-section: 10 mm² (or 2-rated ground wires terminated separately).

For EMC-compliant installation

- Establish electrical contact between the cable shield and the adjustable frequency drive enclosure by using metal cable connectors or by using the clamps provided on the equipment.
- Use high-strand wire to reduce electrical interference.
- Do not use pigtails.

NOTICE!**POTENTIAL EQUALIZATION**

Risk of electrical interference, when the ground potential between the adjustable frequency drive and the control system is different. Install equalizing cables between the system components. Recommended cable cross-section: 16 mm².

4.4 Wiring Schematic

4

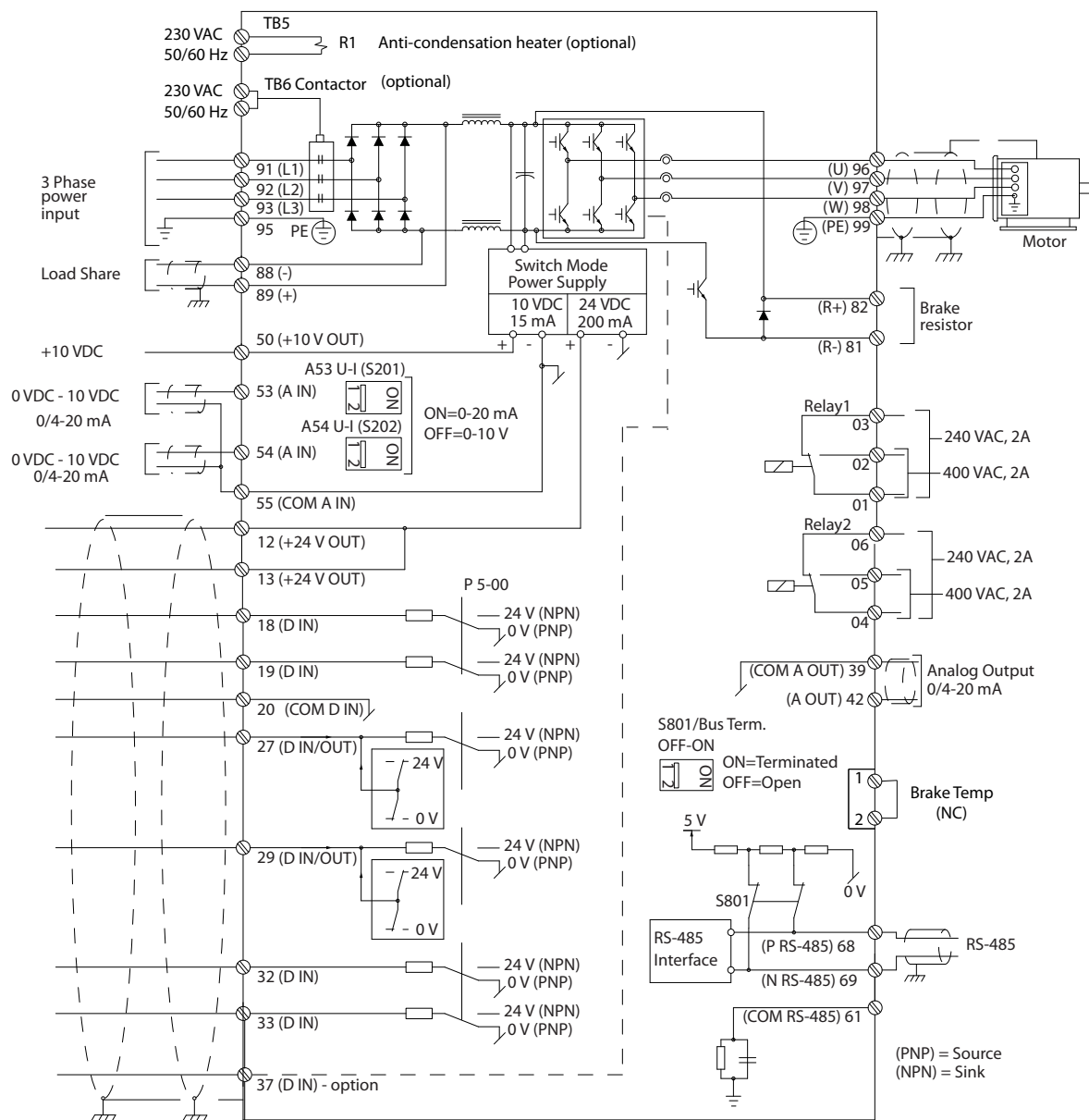

130B0548:12

Figure 4.1 Basic Wiring Schematic

A=Analog, D=Digital

*Terminal 37 (optional) is used for Safe Torque Off. For Safe Torque Off installation instructions, refer to the *Safe Torque Off Instruction Manual for Danfoss VLT® Adjustable Frequency Drives*.

**Do not connect cable shield.

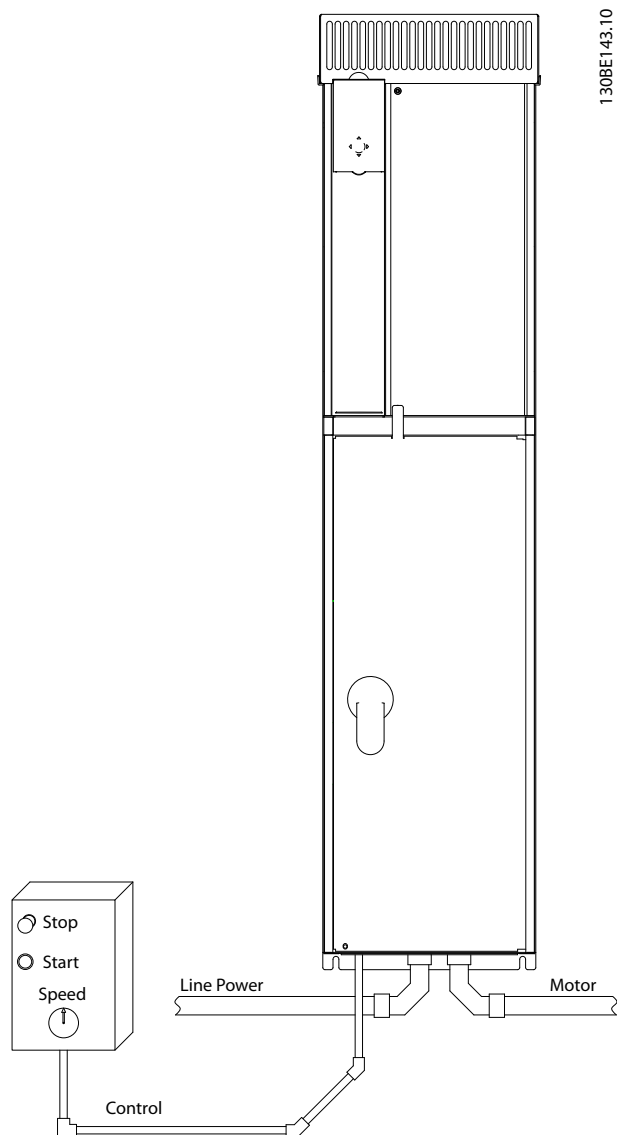

Figure 4.2 Example of Proper Electrical Installation Using Conduit

NOTICE!

EMC INTERFERENCE

Run cables for line power input, motor wiring and control wiring in three separate metallic conduits. Failure to isolate power, motor and control cables can result in unintended behavior or reduced performance. Minimum 200 mm (7.9 in) clearance between line power input, motor and control cables is required.

4.5 Access

All terminals to the control cables are located underneath the LCP on the inside of the adjustable frequency drive. To access, open the door (IP21/54) or remove the front panel (IP20).

4.6 Motor Connection

WARNING

INDUCED VOLTAGE

Induced voltage from output motor cables that run together can charge equipment capacitors even with the equipment turned off and locked out. Failure to run output motor cables separately or use shielded cables or metal conduits could result in death or serious injury.

- Comply with local and national electrical codes for cable sizes. For maximum wire sizes, see *chapter 8.1 Electrical Data*.
- Follow the motor manufacturer wiring requirements.
- Motor wiring knockouts or access panels are provided at the base of IP21 (NEMA1/12) and higher units.
- Do not wire a starting or pole-changing device (for example, Dahlander motor or slip ring induction motor) between the adjustable frequency drive and the motor.

Procedure

1. Strip a section of the outer cable insulation.
2. Position the stripped wire under the cable clamp to establish mechanical fixation and electrical contact between the cable shield and ground.
3. Connect the ground wire to the nearest grounding terminal in accordance with the grounding instructions provided in *chapter 4.3 Grounding*, see *Figure 4.3*.
4. Connect the 3-phase motor wiring to terminals 96 (U), 97 (V), and 98 (W), see *Figure 4.3*.
5. Tighten the terminals in accordance with the information provided in *chapter 8.8 Connection Tightening Torques*.

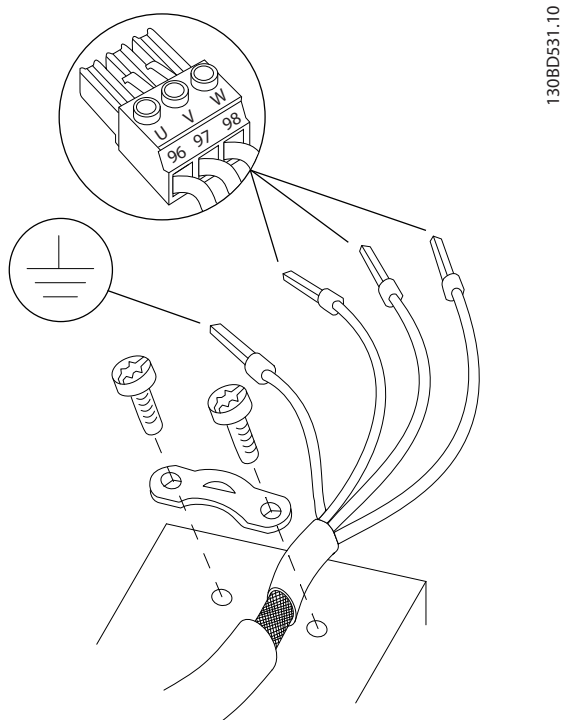

Figure 4.3 Motor Connection

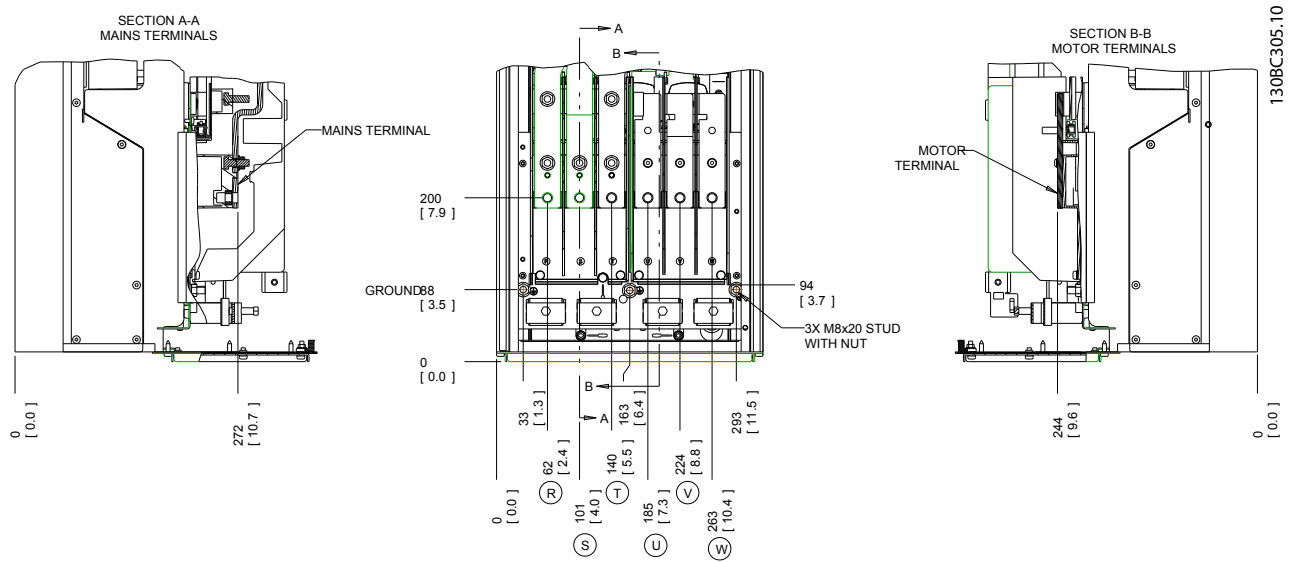

Figure 4.4 Terminal Locations, D1h

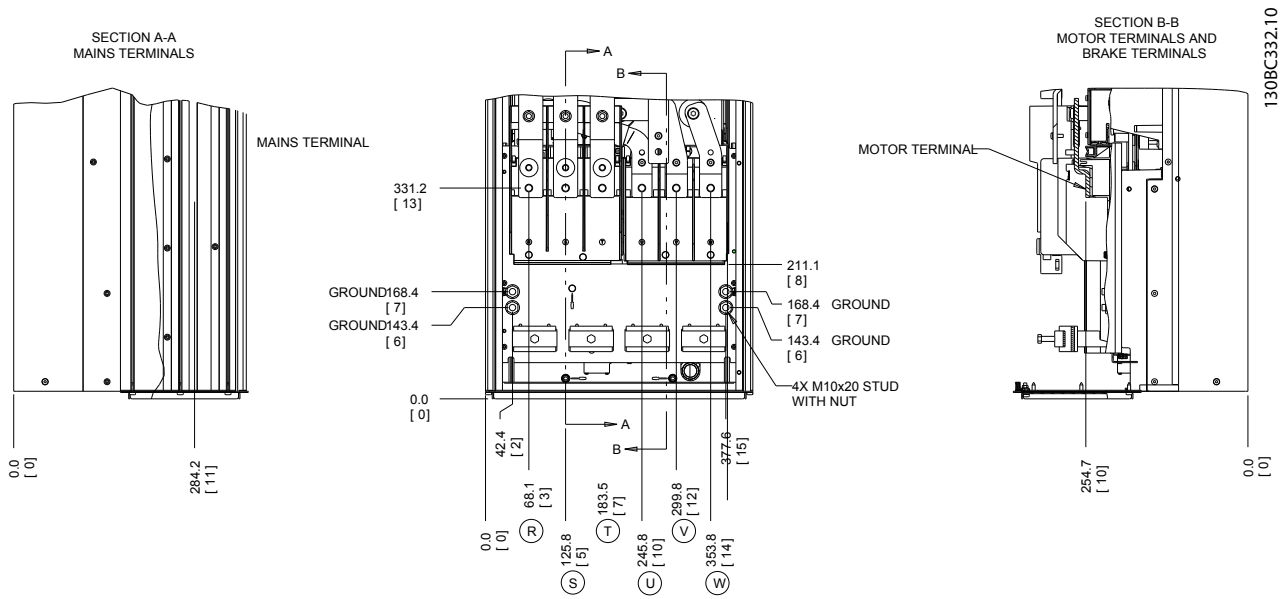

Figure 4.5 Terminal Locations, D2h

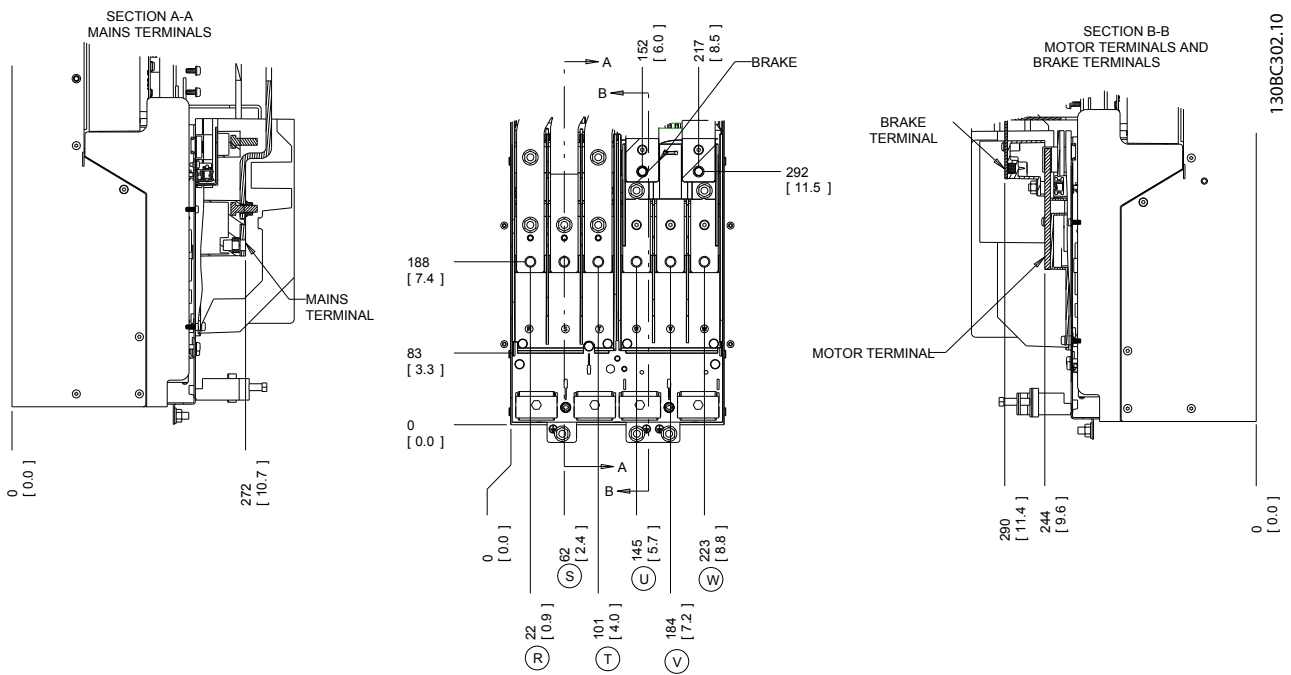
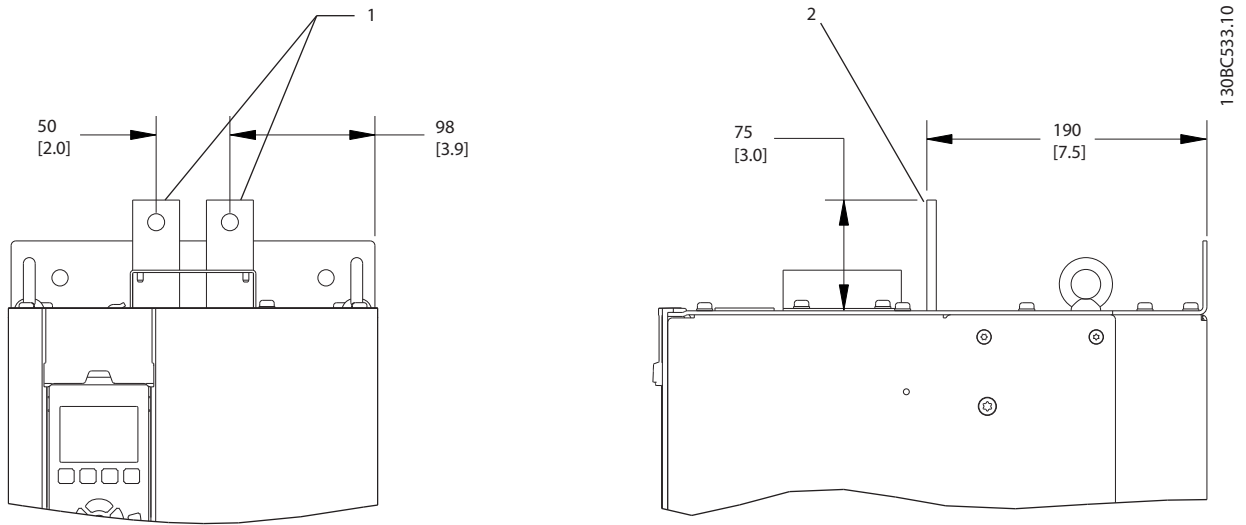

Figure 4.6 Terminal Locations, D3h



1	Front view
2	Side view

Figure 4.7 Load Share and Regeneration Terminals, D3h

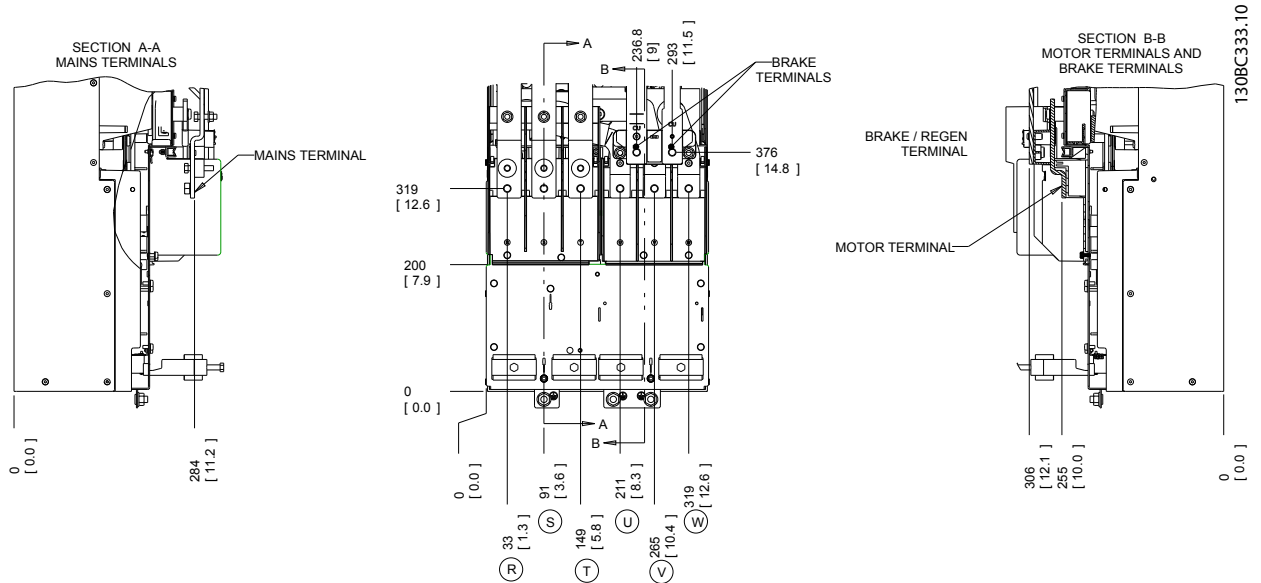
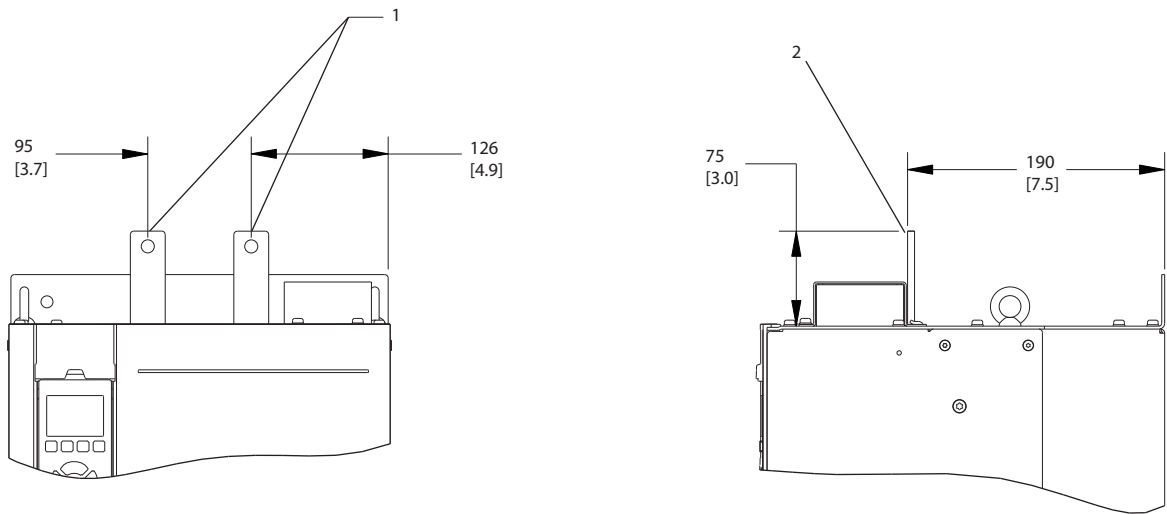

Figure 4.8 Terminal Locations, D4h



130BC534.10

4

1	Front view
2	Side view

Figure 4.9 Load Share and Regeneration Terminals, D4h

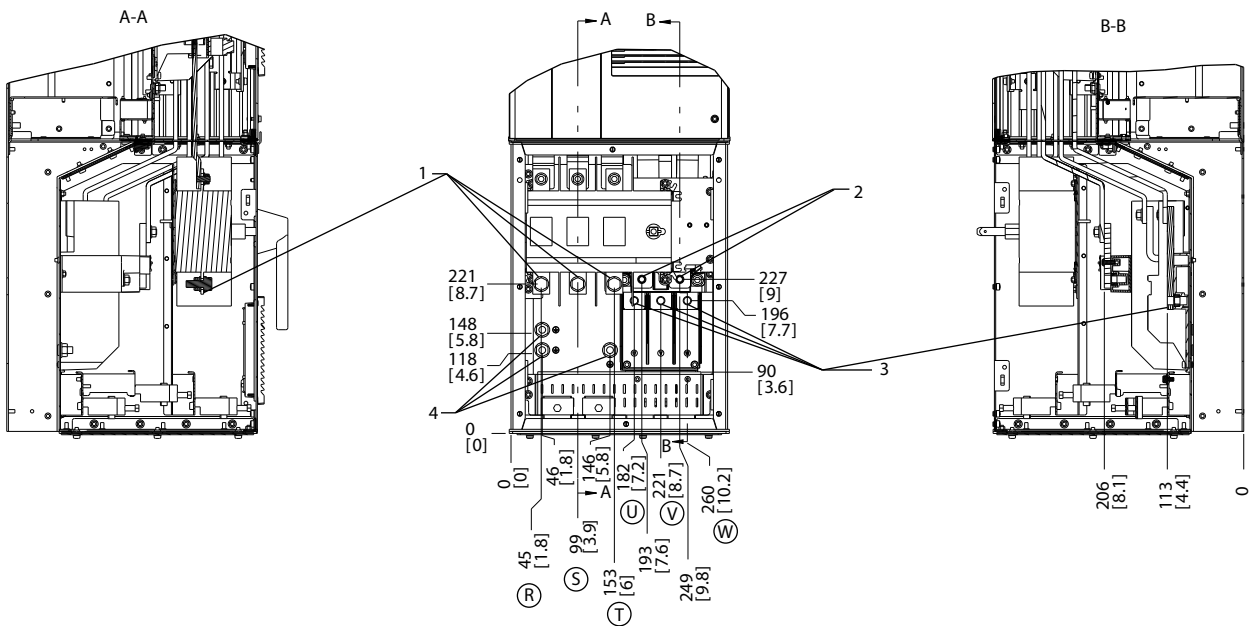

130BC535.11

1	Line power terminals
2	Brake terminals
3	Motor terminals
4	Ground terminals

Figure 4.10 Terminal Locations, D5h with Disconnect Option

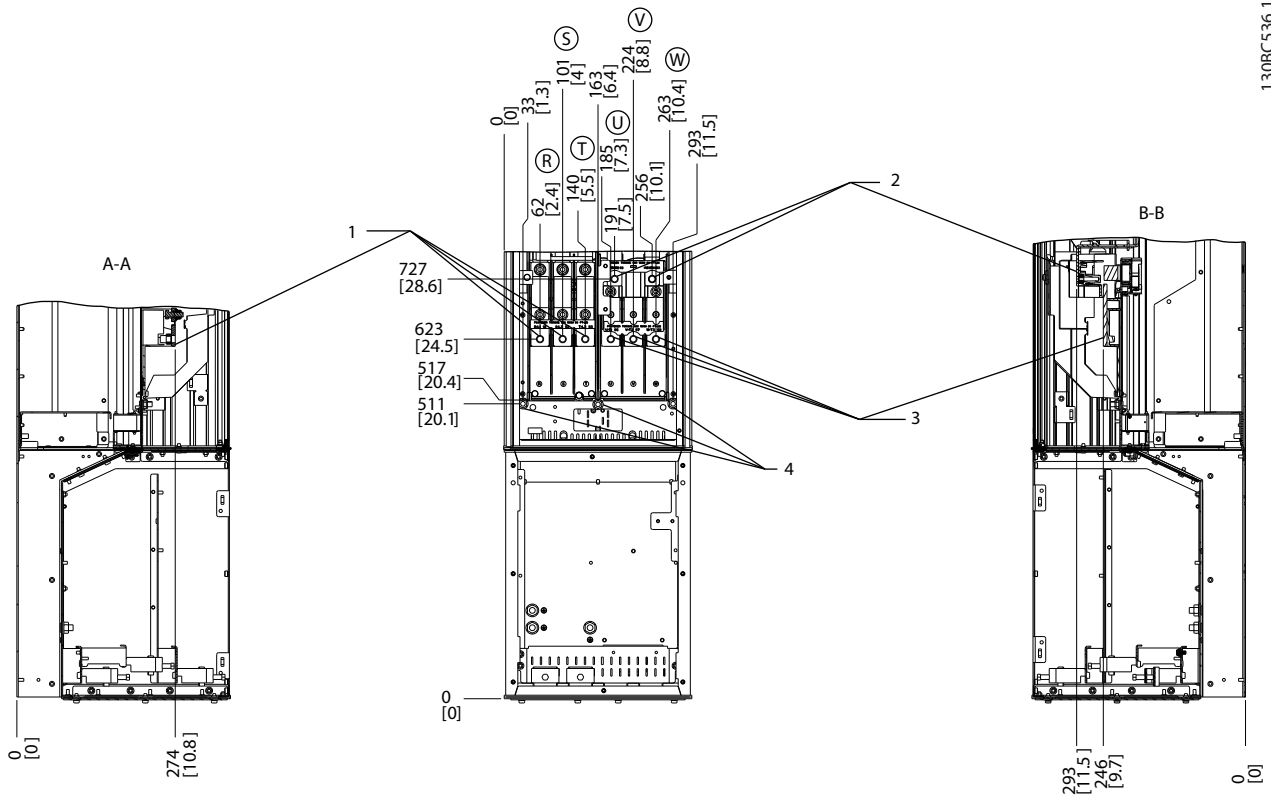

130BC536.11

1	Line power terminals
2	Brake terminals
3	Motor terminals
4	Ground terminals

Figure 4.11 Terminal Locations, D5h with Brake Option

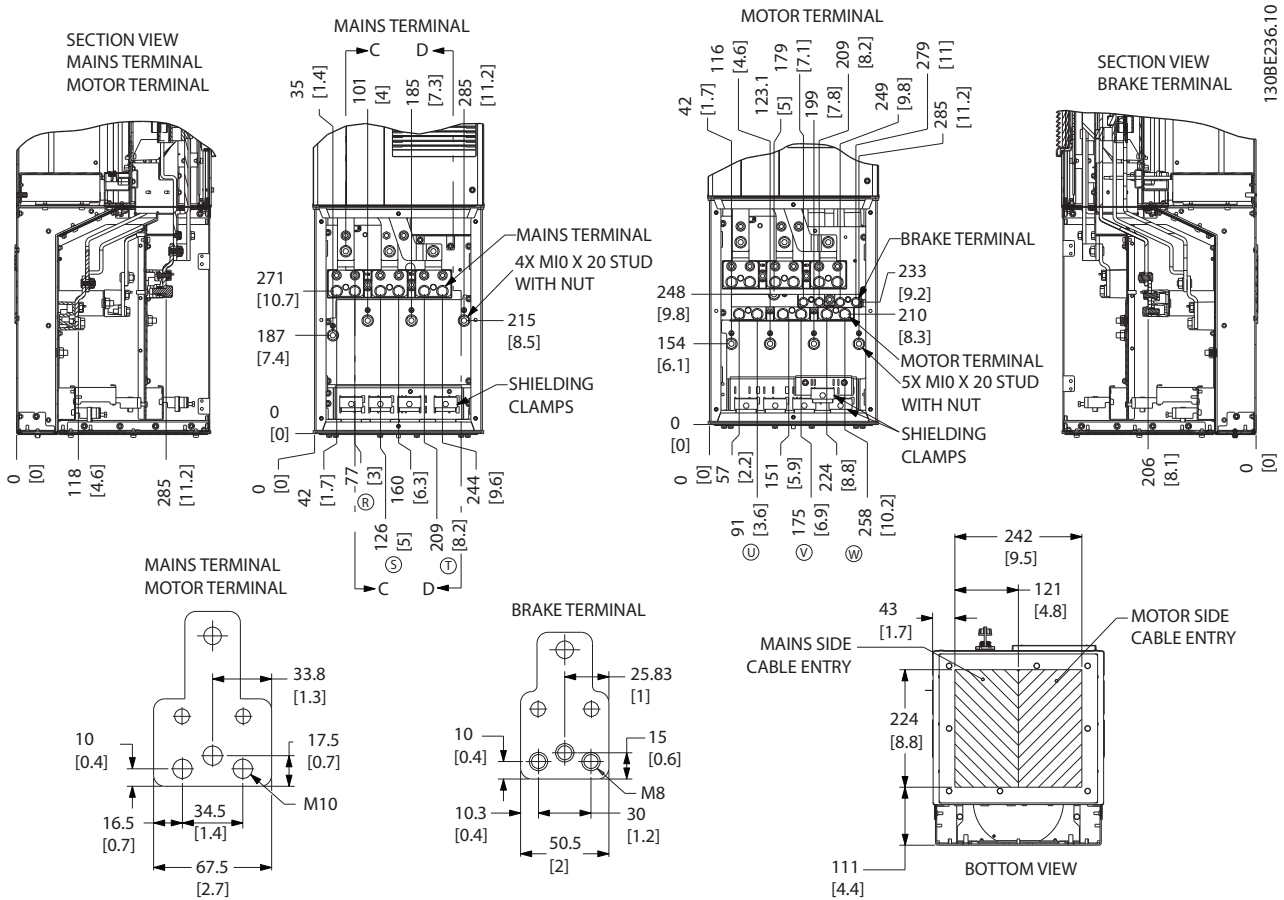
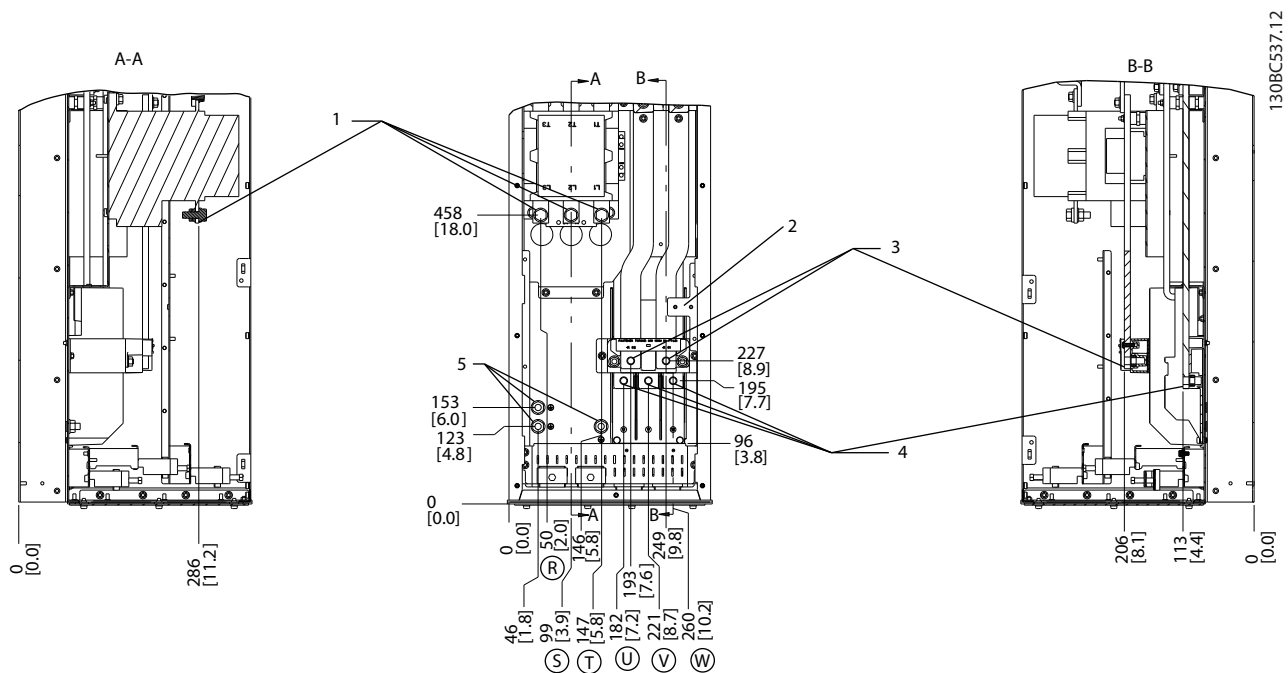

Figure 4.12 Oversized Wiring Cabinet, D5h

4



1	Line power terminals
2	TB6 terminal block for contactor
3	Brake terminals
4	Motor terminals
5	Ground terminals

Figure 4.13 Terminal Locations, D6h with Contactor Option

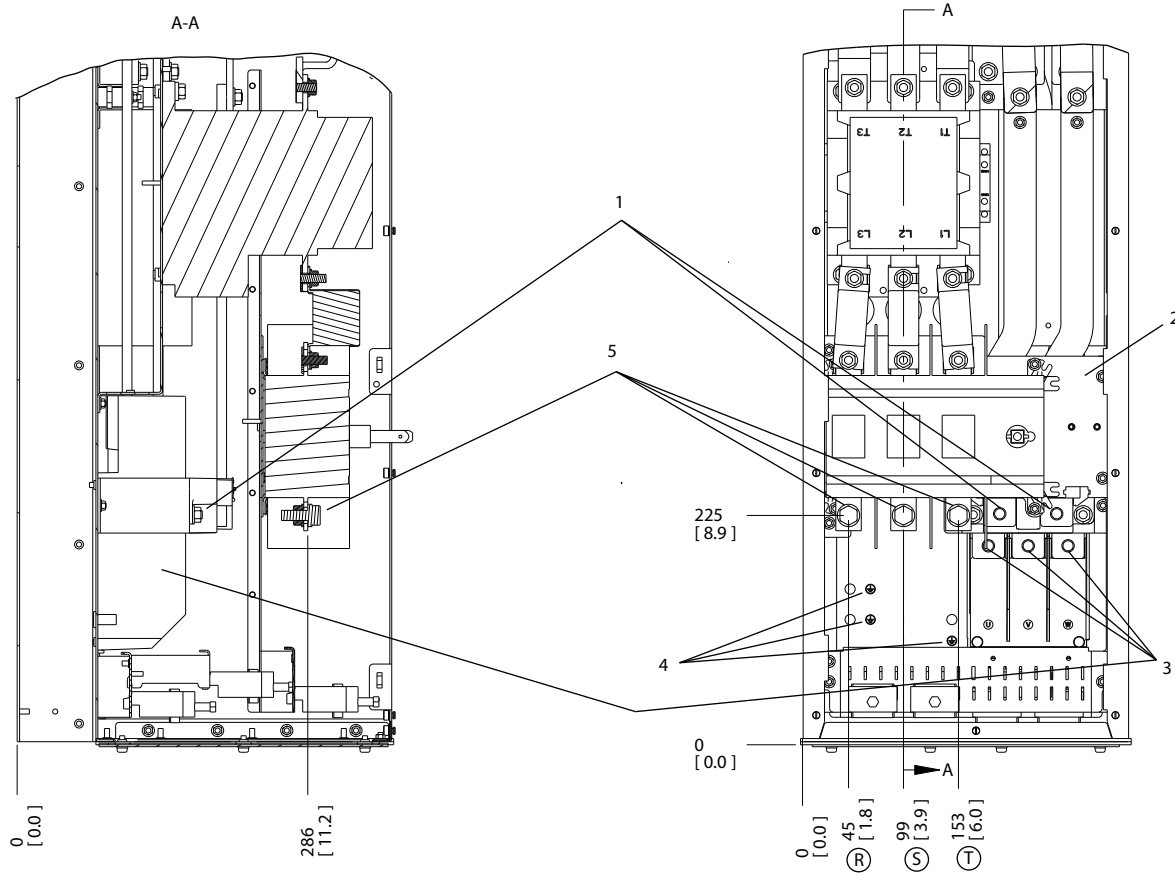

1	Brake terminals
2	TB6 terminal block for contactor
3	Motor terminals
4	Ground terminals
5	Line power terminals

Figure 4.14 Terminal Locations, D6h with Contactor and Disconnect Options

4

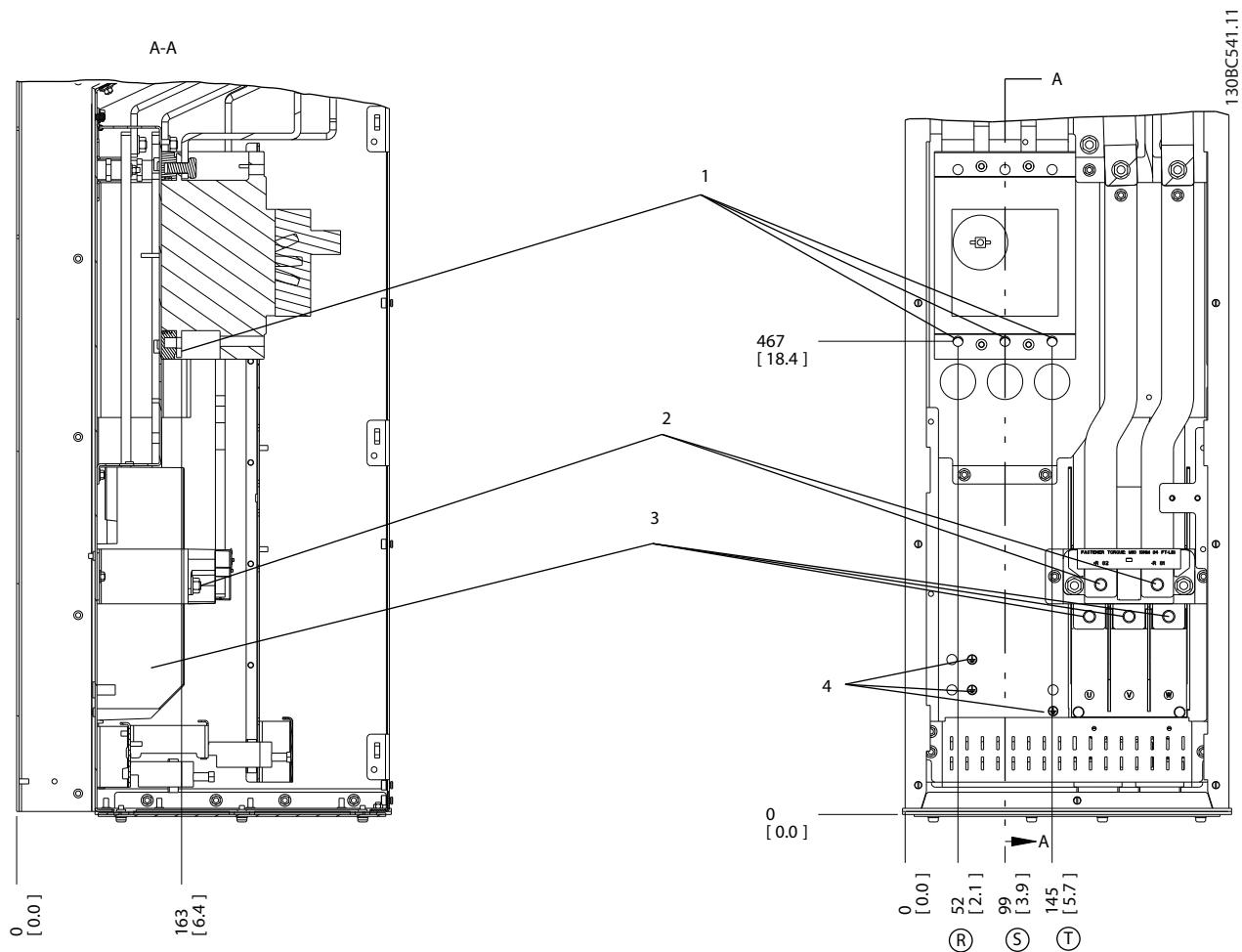

1	Line power terminals
2	Brake terminals
3	Motor terminals
4	Ground terminals

Figure 4.15 Terminal Locations, D6h with Circuit Breaker Option

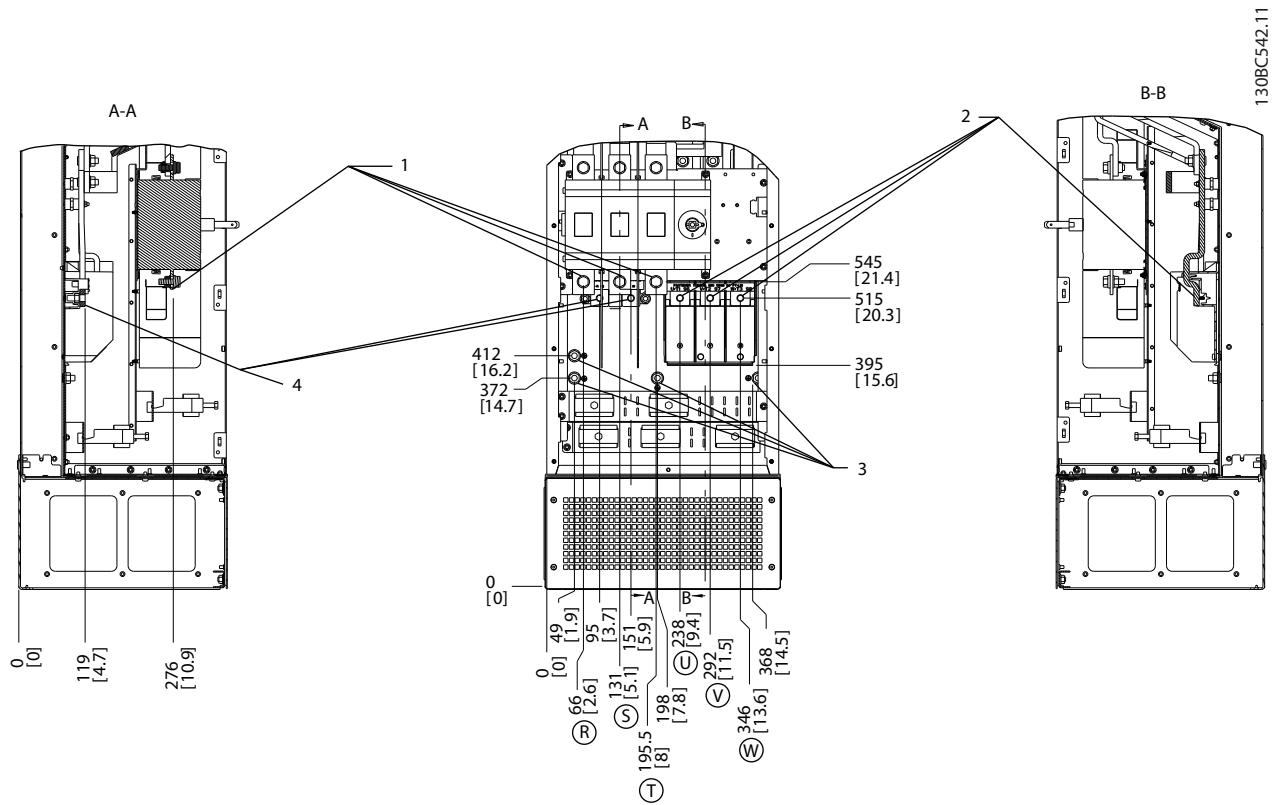

1	Line power terminals
2	Motor terminals
3	Ground terminals
4	Brake terminals

Figure 4.16 Terminal Locations, D7h with Disconnect Option

4

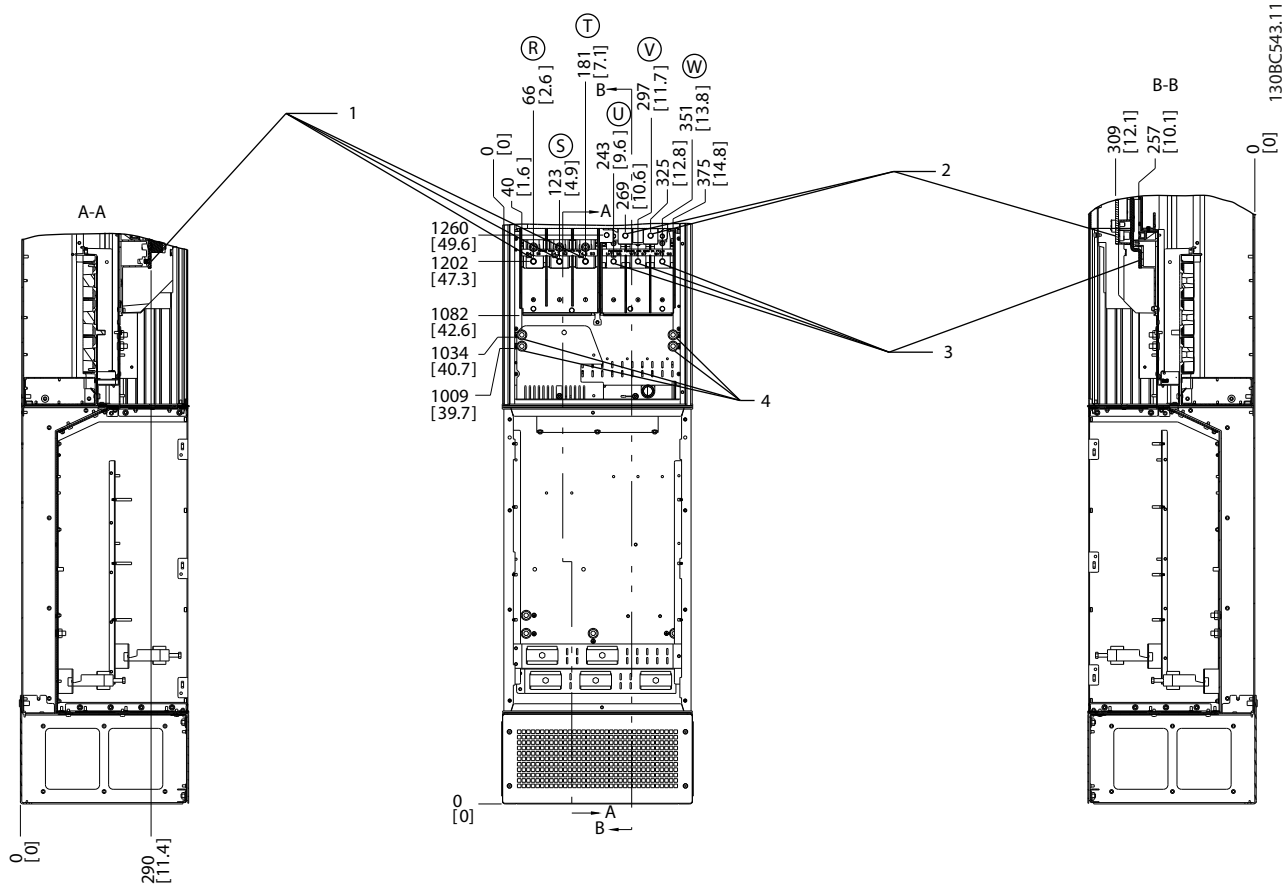

1	Line power terminals
2	Brake terminals
3	Motor terminals
4	Ground terminals

Figure 4.17 Terminal Locations, D7h with Brake Option

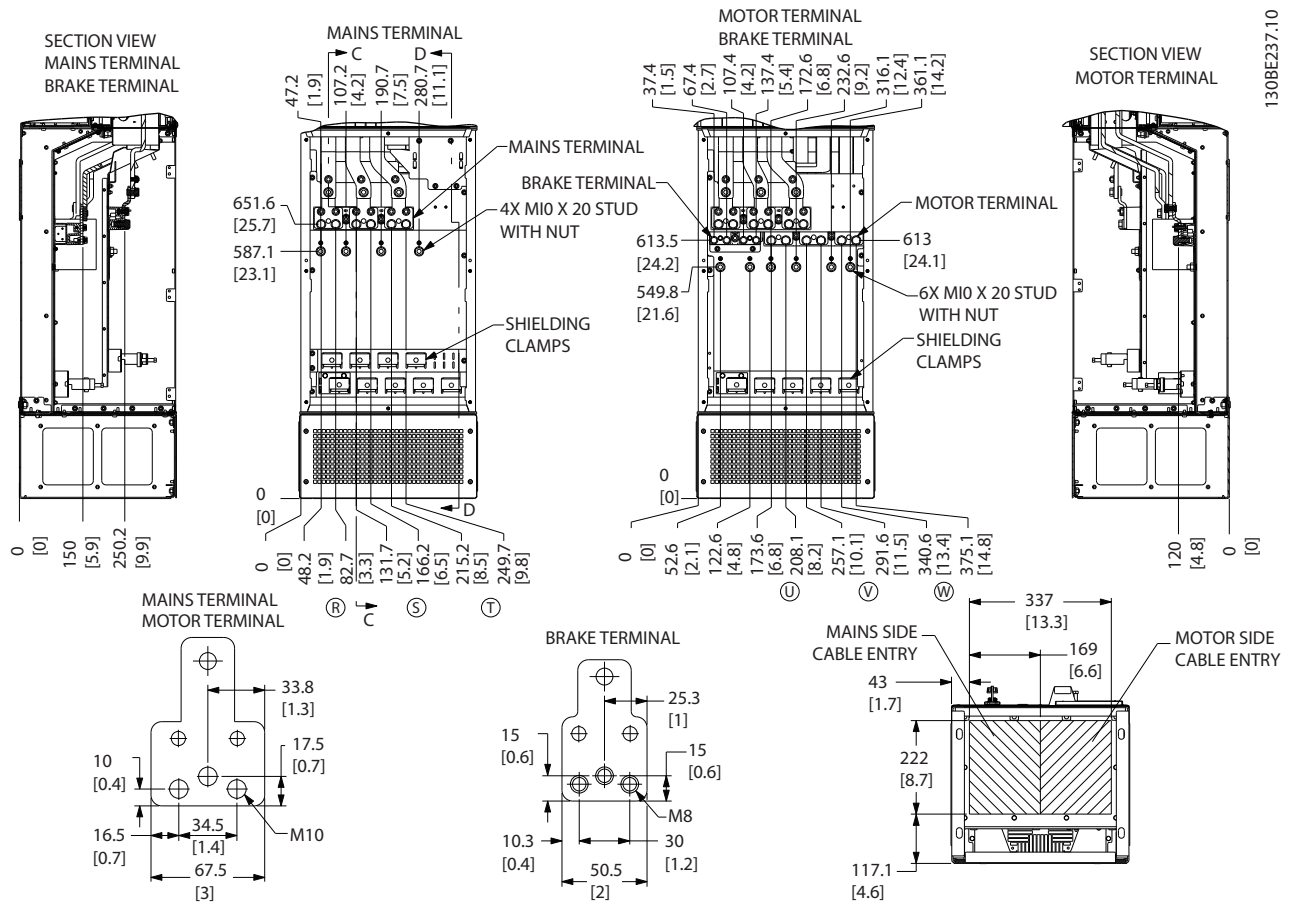
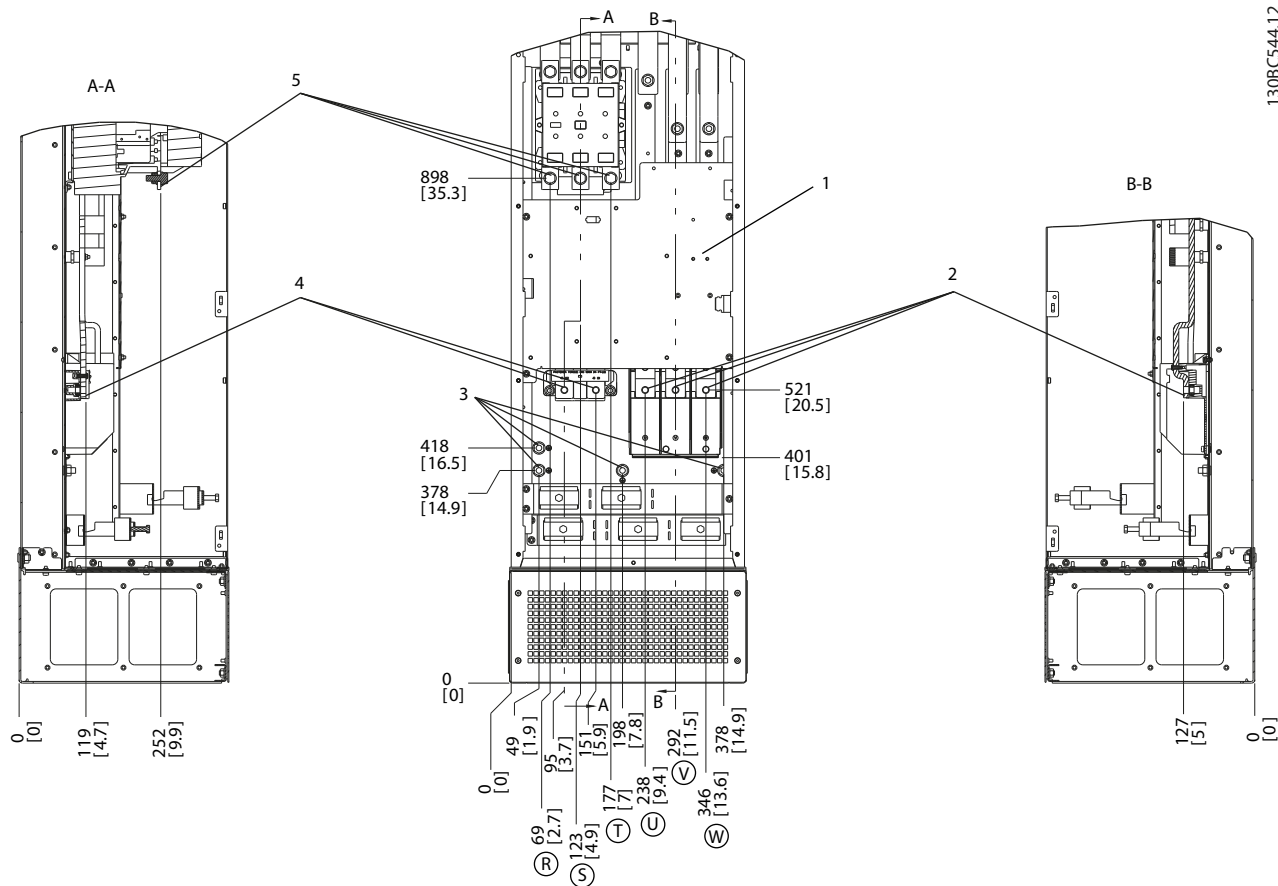

Figure 4.18 Oversized Wiring Cabinet, D7h

4



1308C544.12

1	TB6 terminal block for contactor	4	Brake terminals
2	Motor terminals	5	Line power terminals
3	Ground terminals		

Figure 4.19 Terminal Locations, D8h with Contactor Option

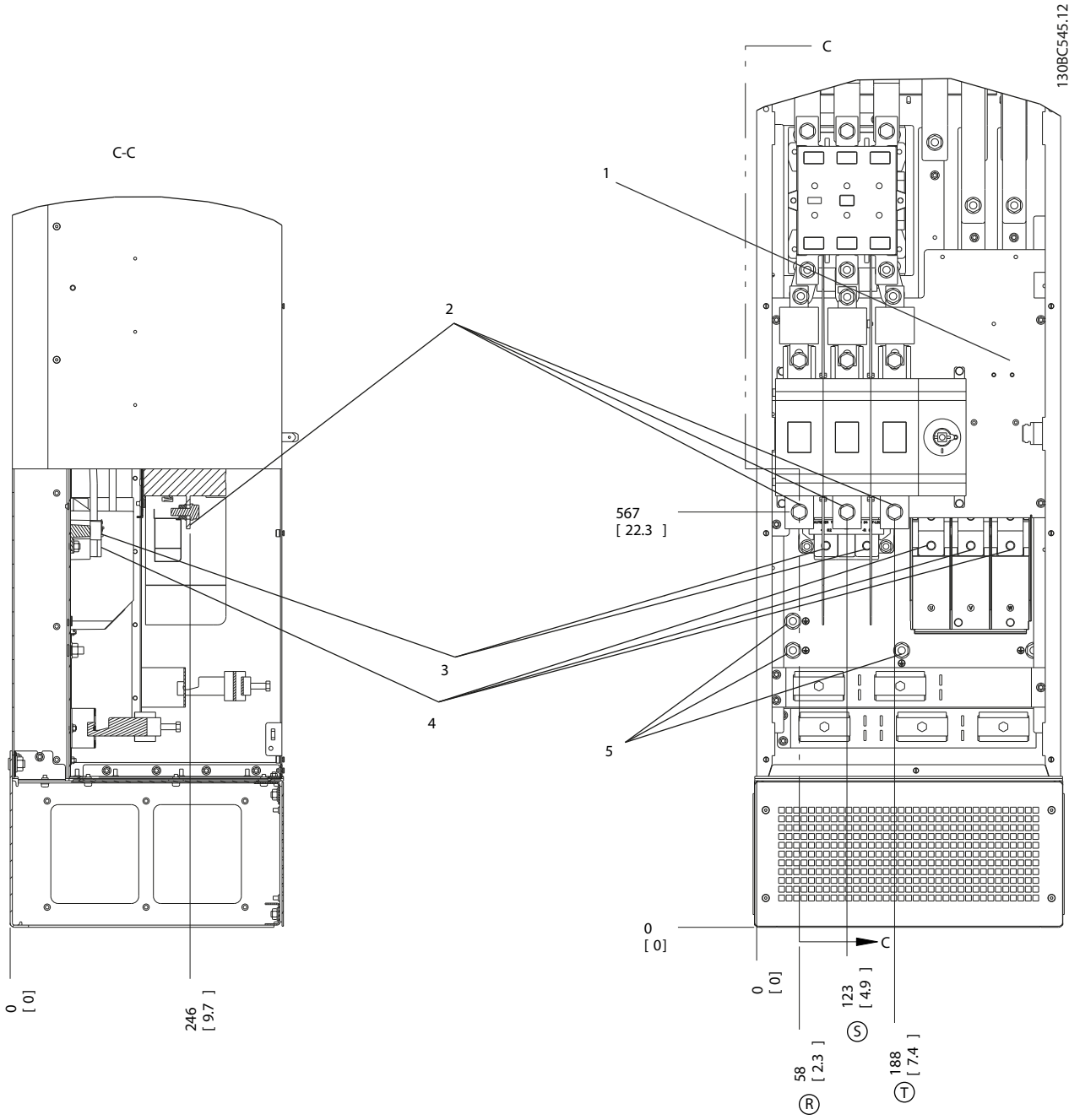

130BC545.12

1	TB6 terminal block for contactor	4	Motor terminals
2	Line power terminals	5	Ground terminals
3	Brake terminals		

Figure 4.20 Terminal Locations, D8h with Contactor and Disconnect Options

4

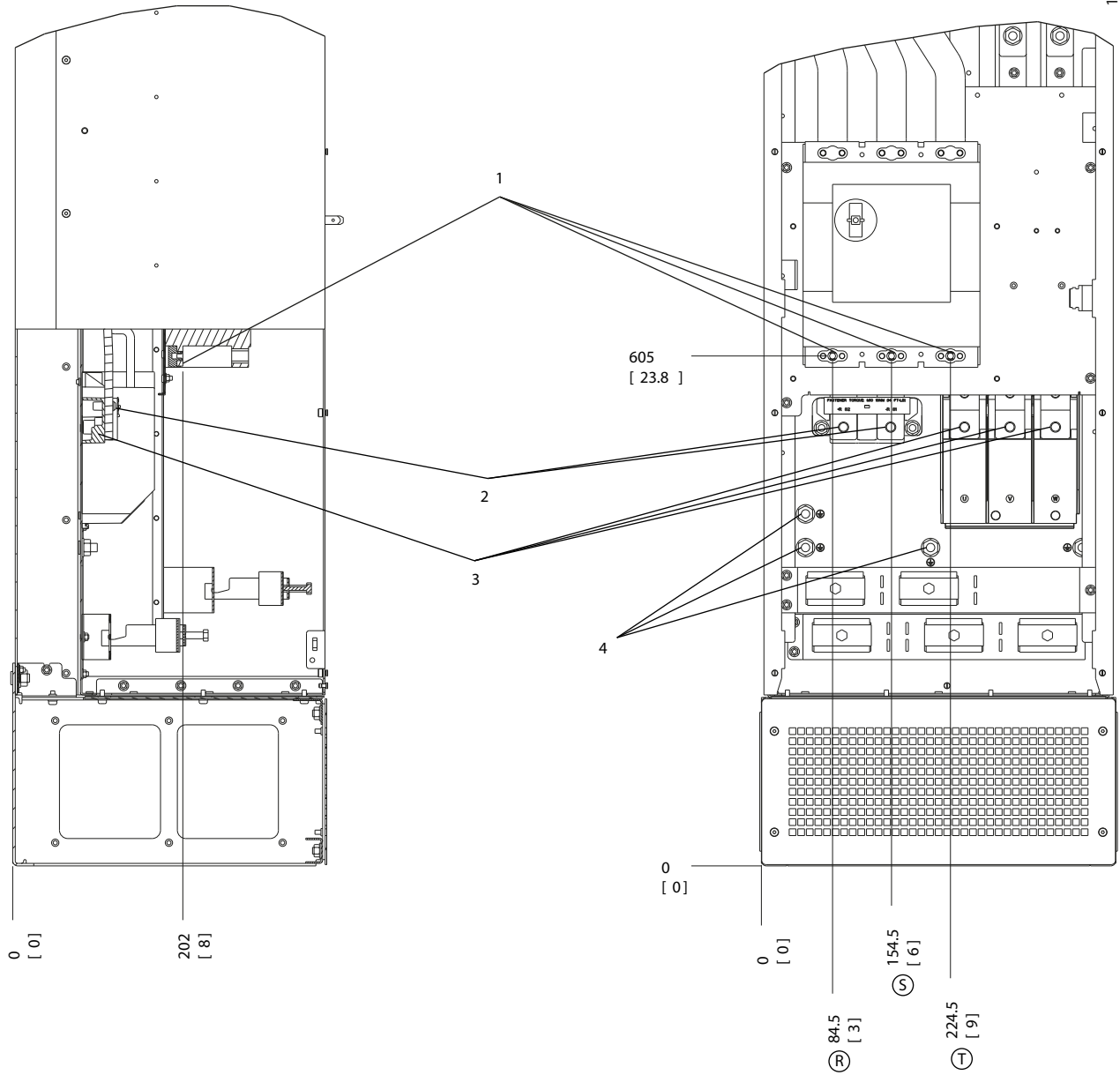

1	Line power terminals	3	Motor terminals
2	Brake terminals	4	Ground terminals

Figure 4.21 Terminal Locations, D8h with Circuit Breaker Option

4.7 AC Line Input Connection

- Size the wiring according to the input current of the adjustable frequency drive. For maximum wire sizes, see *chapter 8.1 Electrical Data*.
- Comply with local and national electrical codes for cable sizes.

Procedure

1. Connect the 3-phase AC input power wiring to terminals R, S, and T (see *Figure 4.22*).
2. Depending on the configuration of the equipment, connect the input power to the line power input terminals or the input disconnect.
3. Ground the cable in accordance with the grounding instructions provided in *chapter 4.3 Grounding*.
4. When supplied from an isolated line power source (IT line power or floating delta) or TT/TN-S line ground with a grounded leg (grounded delta), ensure that *parameter 14-50 RFI 1* is set to [0] Off to avoid damage to the intermediate circuit and to reduce ground capacity currents.

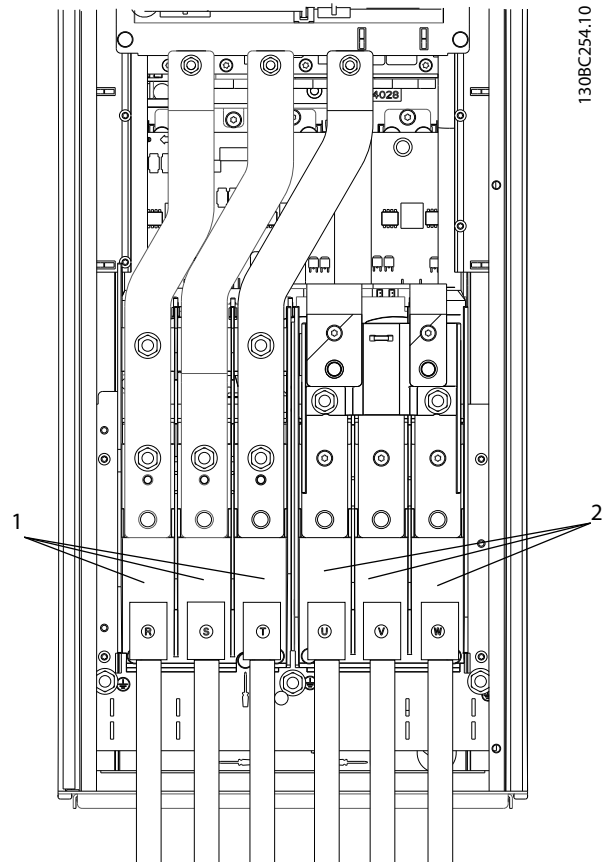

1	AC line input connection (R, S, T)
2	Motor connection (U, V, W)

Figure 4.22 Connecting to AC Line Power

4.8 Control Wiring

- Isolate the control wiring from the high power components in the adjustable frequency drive.
- When the adjustable frequency drive is connected to a thermistor, ensure that the thermistor control wiring is shielded and reinforced/double insulated. A 24 V DC supply voltage is recommended.

4.8.1 Control Terminal Types

Figure 4.23 and *Figure 4.24* show the removable adjustable frequency drive connectors. Terminal functions and default settings are summarized in *Table 4.1* and *Table 4.2*.

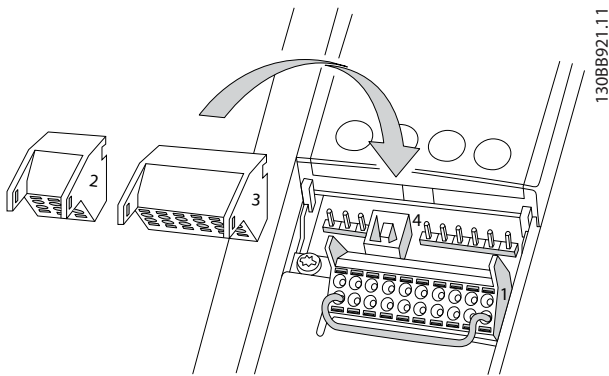

Figure 4.23 Control Terminal Locations

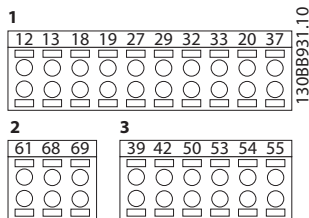

Figure 4.24 Terminal Numbers

- Connector 1 provides four programmable digital inputs terminals, two additional digital terminals programmable as either input or output, a 24 V DC terminal supply voltage, and a common for optional customer supplied 24 V DC voltage. FC 302 and FC 301 (optional in A1 enclosure) also provide a digital input for STO function.
- Connector 2 terminals (+)68 and (-)69 for RS-485 serial communication connection.
- Connector 3 provides two analog inputs, one analog output, 10 V DC supply voltage, and commons for the inputs and output.
- Connector 4 is a USB port available for use with the MCT 10 Set-up Software.

Terminal description			
Terminal	Parameter	Default setting	Description
Digital inputs/outputs			
12, 13	-	+24 V DC	24 V DC supply voltage for digital inputs and external transducers. Maximum output current 200 mA (130 mA for FC 301) for all 24 V loads.
18	5-10	[8] Start	Digital inputs.
19	5-11	[10] Reversing	
32	5-14	[0] No operation	
33	5-15	[0] No operation	
27	5-12	[2] Coast inverse	For digital input or output. Default setting is input.
29	5-13	[14] JOG	
20	-		Common for digital inputs and 0 V potential for 24 V supply.
37	-	STO	Safe input.
Analog inputs/outputs			
39	-		Common for analog output.
42	6-50	[0] No operation	Programmable analog output. 0–20 mA or 4–20 mA at a maximum of 500 Ω.
50	-	+10 V DC	10 V DC analog supply voltage for potentiometer or thermistor. 15 mA maximum
53	6-1*	Reference	Analog input. For voltage or current. Switches A53 and A54 select mA or V.
54	6-2*	Feedback	
55	-		Common for analog input.

Table 4.1 Terminal Description Digital Inputs/Outputs, Analog Inputs/Outputs

Terminal description			
Terminal	Parameter	Default setting	Description
Serial communication			
61	-		Integrated RC filter for cable shield. ONLY for connecting the shield in the event of EMC problems.
68 (+)	8-3*		RS485 interface. A control card switch is provided for termination resistance.
69 (-)	8-3*		
Relays			
01, 02, 03	5-40 [0]	[0] No operation	Form C relay output. For AC or DC voltage and resistive or inductive loads.
04, 05, 06	5-40 [1]	[0] No operation	

Table 4.2 Terminal Description Serial Communication

Additional terminals:

- two form C relay outputs. The location of the outputs depends on the adjustable frequency drive configuration.
- Terminals located on built-in optional equipment. See the manual provided with the equipment option.

4.8.2 Wiring to Control Terminals

Control terminal connectors can be unplugged from the adjustable frequency drive for ease of installation, as shown in *Figure 4.25*.

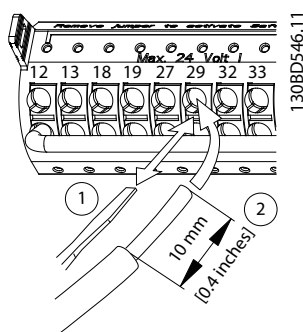

Figure 4.25 Connecting Control Wires

NOTICE!

Keep control wires as short as possible and separate from high power cables to minimize interference.

1. Open the contact by inserting a small screwdriver into the slot above the contact and push the screwdriver slightly upwards.
2. Insert the bare control wire into the contact.
3. Remove the screwdriver to fasten the control wire into the contact.
4. Ensure that the contact is firmly established and not loose. Loose control wiring can be the source of equipment faults or reduced performance.

See *chapter 8.5 Cable Specifications* for control terminal wiring sizes and *chapter 6 Application Set-up Examples* for typical control wiring connections.

4.8.3 Enabling Motor Operation (Terminal 27)

A jumper wire may be required between terminal 12 (or 13) and terminal 27 for the adjustable frequency drive to operate when using factory default programming values.

- Digital input terminal 27 is designed to receive 24 V DC external interlock command.
- When no interlock device is used, wire a jumper between control terminal 12 (recommended) or 13 to terminal 27. This provides an internal 24 V signal on terminal 27.
- When the status line at the bottom of the LCP reads *AUTO REMOTE COAST*, this indicates that the unit is ready to operate but is missing an input signal on terminal 27.
- When factory installed optional equipment is wired to terminal 27, do not remove that wiring.

NOTICE!

The adjustable frequency drive cannot operate without a signal on terminal 27, unless terminal 27 is re-programmed.

4.8.4 Voltage/Current Input Selection (Switches)

The analog input terminals 53 and 54 allow setting of input signal to voltage (0–10 V) or current (0/4–20 mA).

Default parameter setting:

- Terminal 53: Speed reference signal in open-loop (see *parameter 16-61 Terminal 53 Switch Setting*).
- Terminal 54: Feedback signal in closed-loop (see *parameter 16-63 Terminal 54 Switch Setting*).

NOTICE!

Disconnect power to the adjustable frequency drive before changing switch positions.

1. Remove the LCP (local control panel) (see Figure 4.26).
2. Remove any optional equipment covering the switches.
3. Set switches A53 and A54 to select the signal type. U selects voltage, I selects current.

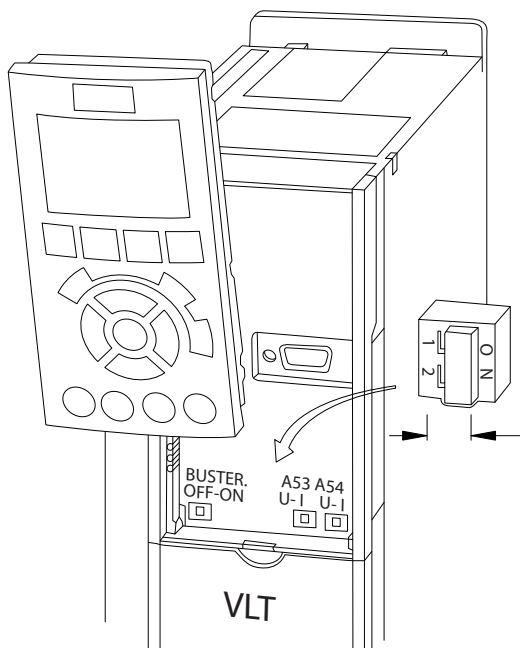

Figure 4.26 Location of Terminal 53 and 54 Switches

4.8.5 Safe Torque Off (STO)

To run STO, additional wiring for the adjustable frequency drive is required. Refer to *VLT® Adjustable Frequency Drives Safe Torque Off Instruction Manual* for further information.

4.8.6 RS485 Serial Communication

Connect RS485 serial communication wiring to terminals (+)68 and (-)69.

- Use shielded serial communication cable (recommended)
- See *chapter 4.3 Grounding* for proper grounding.

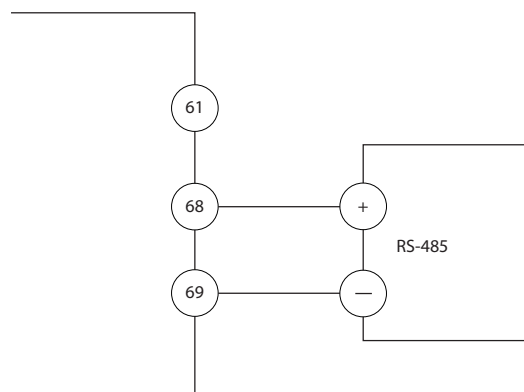

Figure 4.27 Serial Communication Wiring Diagram

For basic serial communication set-up, select the following:

1. Protocol type in *parameter 8-30 Protocol*.
 2. Adjustable frequency drive address in *parameter 8-31 Address*.
 3. Baud rate in *parameter 8-32 Baud Rate*.
- Two communication protocols are internal to the adjustable frequency drive.
 - Danfoss FC
 - Modbus RTU
 - Functions can be programmed remotely using the protocol software and RS485 connection or in parameter group 8-** *Communications and Options*.
 - Selecting a specific communication protocol changes various default parameter settings to match that protocol's specifications and makes additional protocol-specific parameters available.
 - Option cards for the adjustable frequency drive are available to provide additional communication protocols. See the option card documentation for installation and operation instructions.

4.9 Installation Check List

Before completing installation of the unit, inspect the entire installation as detailed in *Table 4.3*. Check and mark the items when completed.

Inspect for	Description	<input checked="" type="checkbox"/>
Auxiliary equipment	<ul style="list-style-type: none"> Look for auxiliary equipment, switches, disconnects, or input fuses/circuit breakers, which may reside on the input power side of the adjustable frequency drive or output side to the motor. Ensure that they are ready for full-speed operation. Check the function and installation of any sensors used for feedback to the adjustable frequency drive. Remove any power factor correction capacitors on the motor(s). Adjust any power factor correction capacitors on the line power side and ensure that they are dampened. 	
Cable routing	<ul style="list-style-type: none"> Ensure that the motor wiring and control wiring are separated, shielded, or in three separate metallic conduits for high-frequency interference isolation. 	
Control wiring	<ul style="list-style-type: none"> Check for broken or damaged wires and loose connections. Check that the control wiring is isolated from power and motor wiring for noise immunity. Check the voltage source of the signals, if necessary. <p>The use of shielded cable or twisted pair is recommended. Ensure that the shield is terminated correctly.</p>	
Cooling clearance	<ul style="list-style-type: none"> Ensure the top and bottom clearance is adequate to ensure proper air flow for cooling, see <i>chapter 3.3 Mounting</i>. 	
Ambient conditions	<ul style="list-style-type: none"> Check that requirements for ambient conditions are met. 	
Fusing and circuit breakers	<ul style="list-style-type: none"> Check for proper fusing or circuit breakers. Check that all fuses are inserted firmly and are in operational condition and that all circuit breakers are in the open position. 	
Grounding	<ul style="list-style-type: none"> Check for sufficient ground connections and ensure the those are tight and free of oxidation. Grounding to conduit, or mounting the back panel to a metal surface, is not a suitable grounding. 	
Input and output power wiring	<ul style="list-style-type: none"> Check for loose connections. Check that the motor and line cables are in separate conduit or separated shielded cables. 	
Panel interior	<ul style="list-style-type: none"> Inspect to ensure that the unit interior is free of dirt, metal chips, moisture, and corrosion. Check that the unit is mounted on an unpainted, metal surface. 	
Switches	<ul style="list-style-type: none"> Ensure that all switch and disconnect settings are in the proper positions. 	
Vibration	<ul style="list-style-type: none"> Check that the unit is mounted solidly, or that shock mounts are used, as necessary. Check for an unusual amount of vibration. 	

Table 4.3 Installation Check List

CAUTION

POTENTIAL HAZARD IN THE EVENT OF INTERNAL FAILURE

Risk of personal injury if the adjustable frequency drive is not properly closed.

- Before applying power, ensure all safety covers are in place and securely fastened.

5 Commissioning

5.1 Safety Instructions

See *chapter 2 Safety* for general safety instructions.

⚠ WARNING

HIGH VOLTAGE

Adjustable frequency drives contain high voltage when connected to AC line power. Failure to perform installation, start-up, and maintenance by qualified personnel could result in death or serious injury.

- Installation, start-up, and maintenance must be performed by qualified personnel only.

Before applying power:

1. Verify that there is no voltage on input terminals L1 (91), L2 (92), and L3 (93), phase-to-phase and phase-to-ground.
2. Verify that there is no voltage on output terminals 96 (U), 97 (V), and 98 (W), phase-to-phase and phase-to-ground.
3. Confirm continuity of the motor by measuring Ω values on U-V (96-97), V-W (97-98), and W-U (98-96).
4. Check for proper grounding of the adjustable frequency drive as well as the motor.
5. Inspect the adjustable frequency drive for loose connections on the terminals.
6. Check that all cable connectors are firmly tightened.
7. Ensure that input power to the unit is OFF and locked out. Do not rely on the adjustable frequency drive disconnect switches for input power isolation.
8. Confirm that the supply voltage matches the voltage of the adjustable frequency drive and the motor.
9. Close the door properly.

5.2 Applying Power

Apply power to the adjustable frequency drive using the following steps:

1. Confirm that the input voltage is balanced within 3%. If not, correct the input voltage imbalance

before proceeding. Repeat this procedure after the voltage correction.

2. Ensure that any optional equipment wiring matches the installation application.
3. Ensure that all operator devices are in the OFF position. Close all panel doors and fasten covers securely.
4. Apply power to the unit. DO NOT start the adjustable frequency drive now. For units with a disconnect switch, turn it to the ON position to apply power to the adjustable frequency drive.

5.3 Local Control Panel Operation

5.3.1 Local Control Panel

The local control panel (LCP) is the combined display and keypad on the front of the unit.

The LCP has several user functions:

- Start, stop, and control speed when in local control.
- Display operational data, status, warnings and cautions.
- Program adjustable frequency drive functions.
- Manually reset the adjustable frequency drive after a fault when auto-reset is inactive.

An optional numeric LCP (NLCP) is also available. The NLCP operates in a manner similar to the LCP. See the product relevant *programming guide* for details on use of the NLCP.

NOTICE!

For commissioning via PC, install the MCT 10 Set-up Software. The software is available for download (basic version) or for ordering (advanced version, order number 130B1000). For more information and downloads, see www.danfoss.com/BusinessAreas/DrivesSolutions/Software+MCT10/MCT10+Downloads.htm.

5.3.2 Start-up Message

NOTICE!

During start-up, the LCP displays the message **INITIALIZING**. When this message is no longer displayed, then the adjustable frequency drive is ready for operation. Adding or removing options can extend the duration of start-up.

5.3.3 LCP Layout

The LCP is divided into four functional groups (see Figure 5.1).

- A. Display area
- B. Display menu keys
- C. Navigation keys and LEDs
- D. Operation keys and reset

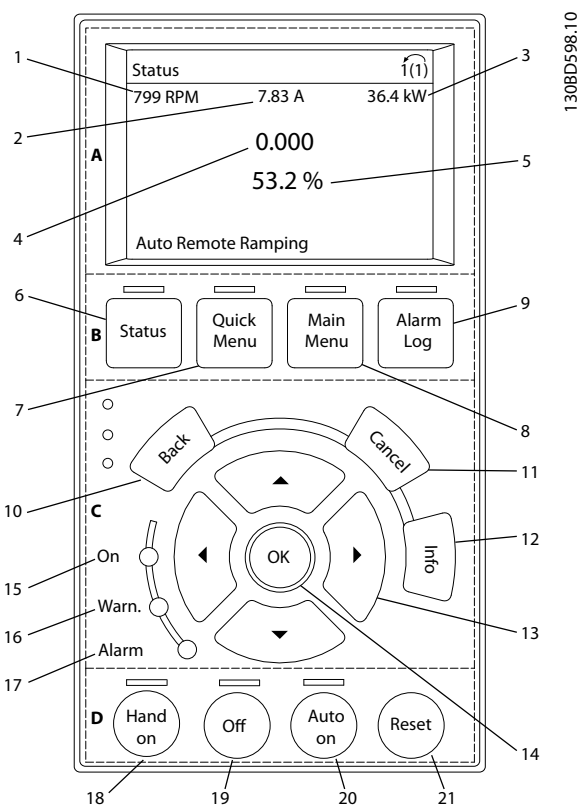

Figure 5.1 Local Control Panel (LCP)

A. Display area

The display area is activated when the adjustable frequency drive receives power from the AC line voltage, a DC bus terminal, or an external 24 V DC supply.

The information displayed on the LCP can be customized for user application. Select options in the *Quick Menu Q3-13 Display Settings*.

Display	Parameter number	Default setting
1	0-20	Speed [RPM]
2	0-21	Motor Current
3	0-22	Power [kW]
4	0-23	Frequency
5	0-24	Reference [%]

Table 5.1 Legend to Figure 5.1, Display Area

B. Display menu keys

Menu keys are used for menu access for parameter set-up, toggling through status display modes during normal operation, and viewing fault log data.

	Key	Function
6	Status	Shows operational information.
7	Quick Menu	Allows access to programming parameters for initial set-up instructions and many detailed application instructions.
8	Main Menu	Allows access to all programming parameters.
9	Alarm Log	Displays a list of current warnings, the last ten alarms, and the maintenance log.

Table 5.2 Legend to Figure 5.1, Display Menu Keys

C. Navigation keys and LEDs

Navigation keys are used for programming functions and moving the display cursor. The navigation keys also provide speed control in local operation. There are also three adjustable frequency drive status indicator lights in this area.

	Key	Function
10	Back	Reverts to the previous step or list in the menu structure.
11	Cancel	Cancels the last change or command as long as the display mode has not changed.
12	Info	Press for a definition of the function being displayed.
13	Navigation keys	Use the four navigation keys to move between items in the menu.
14	OK	Use to access parameter groups or to enable a selection.

Table 5.3 Legend to Figure 5.1, Navigation Keys

	Indicator	Light	Function
15	On	Green	The ON light activates when the adjustable frequency drive receives power from the AC line voltage, a DC bus terminal, or an external 24 V supply.
16	Warn.	Yellow	When warning conditions are met, the yellow WARN light comes on and text appears in the display area identifying the problem.
17	Alarm	Red	A fault condition causes the red alarm light to flash and an alarm text is displayed.

Table 5.4 Legend to Figure 5.1, Indicator Lights (LEDs)

D. Operation keys and reset

Operation keys are located at the bottom of the LCP.

	Key	Function
18	Hand On	Starts the adjustable frequency drive in local control. <ul style="list-style-type: none"> An external stop signal by control input or serial communication overrides the local hand on.
19	Off	Stops the motor but does not remove power to the adjustable frequency drive.
20	Auto On	Puts the system in remote operational mode. <ul style="list-style-type: none"> Responds to an external start command by control terminals or serial communication.
21	Reset	Resets the adjustable frequency drive manually after a fault has been cleared.

Table 5.5 Legend to Figure 5.1, Operation Keys and Reset

NOTICE!

The display contrast can be adjusted by pressing [Status] and the [▲]/[▼] keys.

5.3.4 Parameter Settings

Establishing the correct programming for applications often requires setting functions in several related parameters. Details for parameters are provided in chapter 9.2 *Parameter Menu Structure*.

Programming data is stored internally in the adjustable frequency drive.

- For backup, upload data into the LCP memory.
- To download data to another adjustable frequency drive, connect the LCP to that unit and download the stored settings.

- Restoring factory default settings does not change data stored in the LCP memory.

5.3.5 Uploading/Downloading Data to/from the LCP

- Press [Off] to stop the motor before uploading or downloading data.
- Press [Main Menu], *parameter 0-50 LCP Copy* and press [OK].
- Select [1] *All to LCP* to upload data to the LCP or select [2] *All from LCP* to download data from the LCP.
- Press [OK]. A progress bar shows the uploading or downloading progress.
- Press [Hand On] or [Auto On] to return to normal operation.

5.3.6 Changing Parameter Settings

Parameter settings can be accessed and changed from the *Quick Menu* or from the *Main Menu*. The *Quick Menu* only gives access to a limited number of parameters.

- Press [Quick Menu] or [Main Menu] on the LCP.
- Press [▲] [▼] to browse through the parameter groups, press [OK] to select a parameter group.
- Press [▲] [▼] to browse through the parameters, press [OK] to select a parameter.
- Press [▲] [▼] to change the value of a parameter setting.
- Press [◀] [▶] to shift digit when a decimal parameter is in the editing state.
- Press [OK] to accept the change.
- Press either [Back] twice to enter *Status*, or press [Main Menu] once to enter the *Main Menu*.

View changes

Quick Menu Q5 - Changes Made lists all parameters changed from default settings.

- The list only shows parameters, which have been changed in the current edit set-up.
- Parameters, which have been reset to default values, are not listed.
- The message *Empty* indicates that no parameters have been changed.

5.3.7 Restoring Default Settings

NOTICE!

Risk of losing programming, motor data, localization, and monitoring records by restoration of default settings. To provide a backup, upload data to the LCP before initialization.

Restoring the default parameter settings is done by initialization of the adjustable frequency drive. Initialization is carried out through *parameter 14-22 Operation Mode* (recommended) or manually.

- Initialization using *parameter 14-22 Operation Mode* does not reset adjustable frequency drive settings, such as operating hours, serial communication selections, personal menu settings, fault log, alarm log, and other monitoring functions.
- Manual initialization erases all motor, programming, localization, and monitoring data and restores factory default settings.

Recommended initialization procedure, via *parameter 14-22 Operation Mode*

1. Press [Main Menu] twice to access parameters.
2. Scroll to *parameter 14-22 Operation Mode* and press [OK].
3. Scroll to [2] *Initialization* and press [OK].
4. Remove power to the unit and wait for the display to turn off.
5. Apply power to the unit.

Default parameter settings are restored during start-up. This may take slightly longer than normal.

6. Alarm 80 is displayed.
7. Press [Reset] to return to operation mode.

Manual initialization procedure

1. Remove power to the unit and wait for the display to turn off.
2. Press and hold [Status], [Main Menu], and [OK] at the same time while applying power to the unit (approximately 5 s, or until a click is heard, and the fan starts).

Factory default parameter settings are restored during start-up. This may take slightly longer than normal.

Manual initialization does not reset the following adjustable frequency drive information:

- *Parameter 15-00 Operating hours*
- *Parameter 15-03 Power-ups*
- *Parameter 15-04 Over Temps*
- *Parameter 15-05 Over Volts*

5.4 Basic Programming

5.4.1 Commissioning via [Main Menu]

Recommended parameter settings are intended for start-up and check-out purposes. Application settings may vary.

Enter data with power ON, but before operating the adjustable frequency drive.

1. Press [Main Menu] on the LCP.
2. Press the navigation keys to scroll to parameter group *0-** Operation/Display* and press [OK].

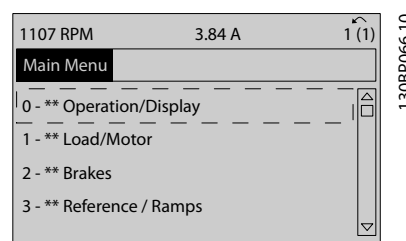

Figure 5.2 Main Menu

3. Press the navigation keys to scroll to parameter group *0-0* Basic Settings* and press [OK].

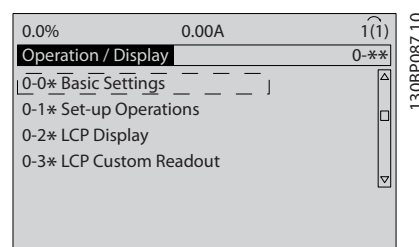

Figure 5.3 Operation/Display

4. Press the navigation keys to scroll to *parameter 0-03 Regional Settings* and press [OK].

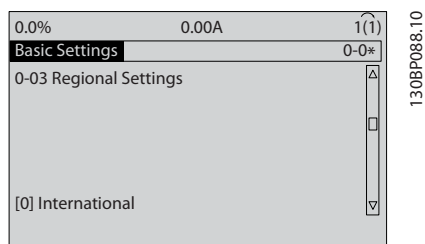

Figure 5.4 Basic Settings

5

5. Press the navigation keys to select *[0] International* or *[1] North America* as appropriate and press [OK]. (This changes the default settings for a number of basic parameters).
6. Press [Main Menu] on the LCP.
7. Press the navigation keys to scroll to *parameter 0-01 Language*.
8. Select the language and press [OK].
9. If a jumper wire is in place between control terminals 12 and 27, leave *parameter 5-12 Terminal 27 Digital Input* at factory default. Otherwise, select *No Operation* in *parameter 5-12 Terminal 27 Digital Input*. For adjustable frequency drives with an optional bypass, no jumper wire is required between control terminals 12 and 27.
10. Make the application specific settings in the following parameters:
 - 10a *Parameter 3-02 Minimum Reference*
 - 10b *Parameter 3-03 Maximum Reference*
 - 10c *Parameter 3-41 Ramp 1 Ramp-up Time*
 - 10d *Parameter 3-42 Ramp 1 Ramp-down Time*
 - 10e *Parameter 3-13 Reference Site*. Linked to Hand/Auto Local Remote.

5.5 Checking Motor Rotation

The direction of rotation can be changed by switching two phases in the motor cable, or by changing the setting of *parameter 4-10 Motor Speed Direction*.

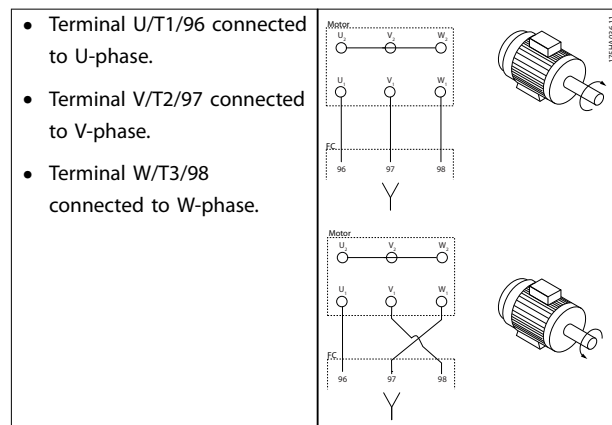

Table 5.6 Wiring for Changing Motor Direction

Perform a motor rotation check using *parameter 1-28 Motor Rotation Check* and following the steps shown in the display.

5.6 Local Control Test

1. Press [Hand On] to provide a local start command to the adjustable frequency drive.
2. Accelerate the adjustable frequency drive by pressing [▲] to full speed. Moving the cursor left of the decimal point provides quicker input changes.
3. Note any acceleration problems.
4. Press [Off]. Note any deceleration problems.

In the event of acceleration or deceleration problems, see *chapter 7.6 Troubleshooting*. See *chapter 7.5 List of Warnings and Alarms* for resetting the adjustable frequency drive after a trip.

5.7 System Start-up

The procedure in this section requires user-wiring and application programming to be completed. The following procedure is recommended after application set-up is completed.

1. Press [Auto On].
2. Apply an external run command.
3. Adjust the speed reference throughout the speed range.
4. Remove the external run command.
5. Check the sound and vibration levels of the motor to ensure that the system is working as intended.

If warnings or alarms occur, see *chapter 7.5 List of Warnings and Alarms*.

6 Application Set-up Examples

6.1 Introduction

The examples in this section are intended as a quick reference for common applications.

- Parameter settings are the regional default values unless otherwise indicated (selected in *parameter 0-03 Regional Settings*).
- Parameters associated with the terminals and their settings are shown next to the drawings.
- Where switch settings for analog terminals A53 or A54 are required, these are also shown.

NOTICE!

When the optional Safe Torque Off feature is used, a jumper wire may be required between terminal 12 (or 13) and terminal 37 for the adjustable frequency drive to operate when using factory default programming values.

6.2 Application Examples

6.2.1 Automatic motor adaptation (AMA)

		Parameters	
FC		Function	Setting
+24 V	12	Parameter 1-29 <i>Automatic Motor Adaptation (AMA)</i>	[1] Enable complete AMA
+24 V	13		
D IN	18		
D IN	19		
COM	20		
D IN	27		
D IN	29		
D IN	32		
D IN	33		
D IN	37		
+10 V	50	Parameter 5-12 <i>Terminal 27 Digital Input</i>	[0] No operation
A IN	53		
A IN	54		
COM	55		
A OUT	42		
COM	39		
		* = Default Value	
		Notes/comments: Parameter group 1-2* <i>Motor Data</i> must be set according to motor. D IN 37 is an option.	

Table 6.2 AMA without T27 connected

		Parameters	
FC		Function	Setting
+24 V	12	Parameter 1-29 <i>Automatic Motor Adaptation (AMA)</i>	[1] Enable complete AMA
+24 V	13		
D IN	18		
D IN	19		
COM	20		
D IN	27		
D IN	29		
D IN	32		
D IN	33		
D IN	37		
+10 V	50	Parameter 5-12 <i>Terminal 27 Digital Input</i>	[2]* Coast inverse
A IN	53		
A IN	54		
COM	55		
A OUT	42		
COM	39		
		* = Default Value	
		Notes/comments: Parameter group 1-2* <i>Motor Data</i> must be set according to motor. D IN 37 is an option.	

Table 6.1 AMA with T27 connected

6.2.2 Speed

6

		Parameters																																			
		Function	Setting																																		
<table border="1"> <tr><th colspan="2">FC</th></tr> <tr><td>+24 V</td><td>12</td></tr> <tr><td>+24 V</td><td>13</td></tr> <tr><td>D IN</td><td>18</td></tr> <tr><td>D IN</td><td>19</td></tr> <tr><td>COM</td><td>20</td></tr> <tr><td>D IN</td><td>27</td></tr> <tr><td>D IN</td><td>29</td></tr> <tr><td>D IN</td><td>32</td></tr> <tr><td>D IN</td><td>33</td></tr> <tr><td>D IN</td><td>37</td></tr> <tr><td>+10 V</td><td>50</td></tr> <tr><td>A IN</td><td>53</td></tr> <tr><td>A IN</td><td>54</td></tr> <tr><td>COM</td><td>55</td></tr> <tr><td>A OUT</td><td>42</td></tr> <tr><td>COM</td><td>39</td></tr> </table>	FC		+24 V	12	+24 V	13	D IN	18	D IN	19	COM	20	D IN	27	D IN	29	D IN	32	D IN	33	D IN	37	+10 V	50	A IN	53	A IN	54	COM	55	A OUT	42	COM	39	<p>130BB926.10</p>	Parameter 6-10 Terminal 53 Low Voltage	0.07 V*
	FC																																				
	+24 V	12																																			
	+24 V	13																																			
	D IN	18																																			
	D IN	19																																			
	COM	20																																			
	D IN	27																																			
	D IN	29																																			
	D IN	32																																			
	D IN	33																																			
	D IN	37																																			
	+10 V	50																																			
	A IN	53																																			
	A IN	54																																			
COM	55																																				
A OUT	42																																				
COM	39																																				
Parameter 6-11 Terminal 53 High Voltage	10 V*																																				
Parameter 6-14 Terminal 53 Low Ref./Feedb. Value	0 RPM																																				
Parameter 6-15 Terminal 53 High Ref./Feedb. Value	1500 RPM																																				
* = Default Value																																					
Notes/comments: D IN 37 is an option.																																					

Table 6.3 Analog Speed Reference (Voltage)

		Parameters																																			
		Function	Setting																																		
<table border="1"> <tr><th colspan="2">FC</th></tr> <tr><td>+24 V</td><td>12</td></tr> <tr><td>+24 V</td><td>13</td></tr> <tr><td>D IN</td><td>18</td></tr> <tr><td>D IN</td><td>19</td></tr> <tr><td>COM</td><td>20</td></tr> <tr><td>D IN</td><td>27</td></tr> <tr><td>D IN</td><td>29</td></tr> <tr><td>D IN</td><td>32</td></tr> <tr><td>D IN</td><td>33</td></tr> <tr><td>D IN</td><td>37</td></tr> <tr><td>+10 V</td><td>50</td></tr> <tr><td>A IN</td><td>53</td></tr> <tr><td>A IN</td><td>54</td></tr> <tr><td>COM</td><td>55</td></tr> <tr><td>A OUT</td><td>42</td></tr> <tr><td>COM</td><td>39</td></tr> </table>	FC		+24 V	12	+24 V	13	D IN	18	D IN	19	COM	20	D IN	27	D IN	29	D IN	32	D IN	33	D IN	37	+10 V	50	A IN	53	A IN	54	COM	55	A OUT	42	COM	39	<p>130BB927.10</p>	Parameter 6-12 Terminal 53 Low Current	4 mA*
	FC																																				
	+24 V	12																																			
	+24 V	13																																			
	D IN	18																																			
	D IN	19																																			
	COM	20																																			
	D IN	27																																			
	D IN	29																																			
	D IN	32																																			
	D IN	33																																			
	D IN	37																																			
	+10 V	50																																			
	A IN	53																																			
	A IN	54																																			
COM	55																																				
A OUT	42																																				
COM	39																																				
Parameter 6-13 Terminal 53 High Current	20 mA*																																				
Parameter 6-14 Terminal 53 Low Ref./Feedb. Value	0 RPM																																				
Parameter 6-15 Terminal 53 High Ref./Feedb. Value	1500 RPM																																				
* = Default Value																																					
Notes/comments: D IN 37 is an option.																																					

Table 6.4 Analog Speed Reference (Current)

		Parameters																																			
		Function	Setting																																		
<table border="1"> <tr><th colspan="2">FC</th></tr> <tr><td>+24 V</td><td>12</td></tr> <tr><td>+24 V</td><td>13</td></tr> <tr><td>D IN</td><td>18</td></tr> <tr><td>D IN</td><td>19</td></tr> <tr><td>COM</td><td>20</td></tr> <tr><td>D IN</td><td>27</td></tr> <tr><td>D IN</td><td>29</td></tr> <tr><td>D IN</td><td>32</td></tr> <tr><td>D IN</td><td>33</td></tr> <tr><td>D IN</td><td>37</td></tr> <tr><td>+10 V</td><td>50</td></tr> <tr><td>A IN</td><td>53</td></tr> <tr><td>A IN</td><td>54</td></tr> <tr><td>COM</td><td>55</td></tr> <tr><td>A OUT</td><td>42</td></tr> <tr><td>COM</td><td>39</td></tr> </table>	FC		+24 V	12	+24 V	13	D IN	18	D IN	19	COM	20	D IN	27	D IN	29	D IN	32	D IN	33	D IN	37	+10 V	50	A IN	53	A IN	54	COM	55	A OUT	42	COM	39	<p>130BB683.10</p>	Parameter 6-10 Terminal 53 Low Voltage	0.07 V*
	FC																																				
	+24 V	12																																			
	+24 V	13																																			
	D IN	18																																			
	D IN	19																																			
	COM	20																																			
	D IN	27																																			
	D IN	29																																			
	D IN	32																																			
	D IN	33																																			
	D IN	37																																			
	+10 V	50																																			
	A IN	53																																			
	A IN	54																																			
COM	55																																				
A OUT	42																																				
COM	39																																				
Parameter 6-11 Terminal 53 High Voltage	10 V*																																				
Parameter 6-14 Terminal 53 Low Ref./Feedb. Value	0 RPM																																				
Parameter 6-15 Terminal 53 High Ref./Feedb. Value	1500 RPM																																				
* = Default Value																																					
Notes/comments: D IN 37 is an option.																																					

Table 6.5 Speed Reference (using a Manual Potentiometer)

		Parameters																																			
		Function	Setting																																		
<table border="1"> <tr><th colspan="2">FC</th></tr> <tr><td>+24 V</td><td>12</td></tr> <tr><td>+24 V</td><td>13</td></tr> <tr><td>D IN</td><td>18</td></tr> <tr><td>D IN</td><td>19</td></tr> <tr><td>COM</td><td>20</td></tr> <tr><td>D IN</td><td>27</td></tr> <tr><td>D IN</td><td>29</td></tr> <tr><td>D IN</td><td>32</td></tr> <tr><td>D IN</td><td>33</td></tr> <tr><td>D IN</td><td>37</td></tr> <tr><td>+10 V</td><td>50</td></tr> <tr><td>A IN</td><td>53</td></tr> <tr><td>A IN</td><td>54</td></tr> <tr><td>COM</td><td>55</td></tr> <tr><td>A OUT</td><td>42</td></tr> <tr><td>COM</td><td>39</td></tr> </table>	FC		+24 V	12	+24 V	13	D IN	18	D IN	19	COM	20	D IN	27	D IN	29	D IN	32	D IN	33	D IN	37	+10 V	50	A IN	53	A IN	54	COM	55	A OUT	42	COM	39	<p>130BB804.10</p>	Parameter 5-10 Terminal 18 Digital Input	[8] Start*
	FC																																				
	+24 V	12																																			
	+24 V	13																																			
	D IN	18																																			
	D IN	19																																			
	COM	20																																			
	D IN	27																																			
	D IN	29																																			
	D IN	32																																			
	D IN	33																																			
	D IN	37																																			
	+10 V	50																																			
	A IN	53																																			
	A IN	54																																			
COM	55																																				
A OUT	42																																				
COM	39																																				
Parameter 5-12 Terminal 27 Digital Input	[19] Freeze Reference																																				
Parameter 5-13 Terminal 29 Digital Input	[21] Speed Up																																				
Parameter 5-14 Terminal 32 Digital Input	[22] Slow																																				
* = Default Value																																					
Notes/comments: D IN 37 is an option.																																					

Table 6.6 Speed Up/Down

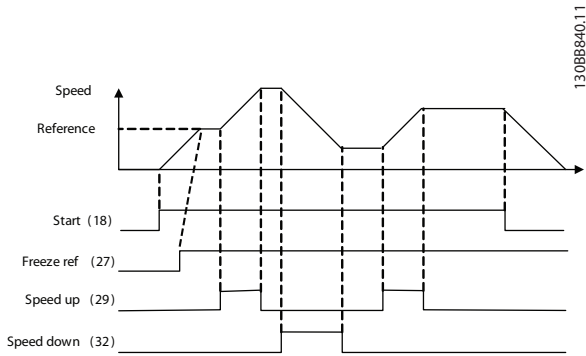

Figure 6.1 Speed Up/Down

6.2.3 Start/Stop

FC		Parameters	
Function	Setting	Function	Setting
Parameter 5-10 Terminal 18 Digital Input	[8] Start*	Parameter 5-12 Terminal 27 Digital Input	[0] No operation
Parameter 5-19 Terminal 37 Safe Stop	[1] Safe Alarm		
* = Default Value			
Notes/comments: If parameter 5-12 Terminal 27 Digital Input is set to [0] No operation, a jumper wire to terminal 27 is not needed. D IN 37 is an option.			

Table 6.7 Start/Stop Command with Safe Stop Option

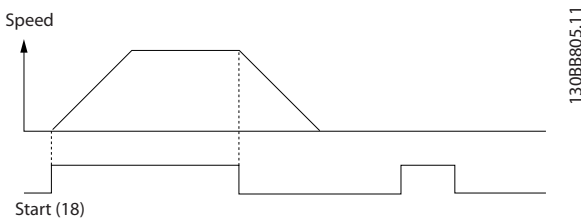

Figure 6.2 Start/Stop Command with Safe Stop

FC		Parameters	
Function	Setting	Function	Setting
Parameter 5-10 Terminal 18 Digital Input	[9] Latched Start	Parameter 5-12 Terminal 27 Digital Input	[6] Stop Inverse
* = Default Value			
Notes/comments: If parameter 5-12 Terminal 27 Digital Input is set to [0] No operation, a jumper wire to terminal 27 is not needed. D IN 37 is an option.			

Table 6.8 Pulse Start/Stop

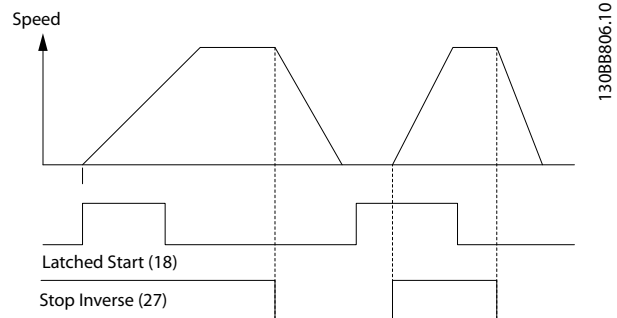

Figure 6.3 Latched Start/Stop Inverse

6

		Parameters	
		Function	Setting
		Parameter 5-10 Terminal 18 Digital Input	[8] Start
		Parameter 5-11 Terminal 19 Digital Input	[10] Reversing *
		Parameter 5-12 Terminal 27 Digital Input	[0] No operation
		Parameter 5-14 Terminal 32 Digital Input	[16] Preset ref bit 0
		Parameter 5-15 Terminal 33 Digital Input	[17] Preset ref bit 1
		Parameter 3-10 Preset Reference	Preset ref. 0 25% Preset ref. 1 50% Preset ref. 2 75% Preset ref. 3 100%
		* = Default Value	
		Notes/comments: D IN 37 is an option.	

Table 6.9 Start/Stop with Reversing and Four Preset Speeds

6.2.4 External Alarm Reset

		Parameters	
		Function	Setting
		Parameter 5-11 Terminal 19 Digital Input	[1] Reset
		* = Default Value	
		Notes/comments: D IN 37 is an option.	

Table 6.10 External Alarm Reset

6.2.5 RS485

		Parameters																																																													
		Function	Setting																																																												
<table border="1"> <thead> <tr> <th colspan="2">FC</th> </tr> </thead> <tbody> <tr><td>+24 V</td><td>12</td></tr> <tr><td>+24 V</td><td>13</td></tr> <tr><td>D IN</td><td>18</td></tr> <tr><td>D IN</td><td>19</td></tr> <tr><td>COM</td><td>20</td></tr> <tr><td>D IN</td><td>27</td></tr> <tr><td>D IN</td><td>29</td></tr> <tr><td>D IN</td><td>32</td></tr> <tr><td>D IN</td><td>33</td></tr> <tr><td>D IN</td><td>37</td></tr> <tr><td colspan="2"> </td></tr> <tr><td>+10V</td><td>50</td></tr> <tr><td>A IN</td><td>53</td></tr> <tr><td>A IN</td><td>54</td></tr> <tr><td>COM</td><td>55</td></tr> <tr><td>A OUT</td><td>42</td></tr> <tr><td>COM</td><td>39</td></tr> <tr><td colspan="2"> </td></tr> <tr><td>R1</td><td>01</td></tr> <tr><td></td><td>02</td></tr> <tr><td></td><td>03</td></tr> <tr><td colspan="2"> </td></tr> <tr><td>R2</td><td>04</td></tr> <tr><td></td><td>05</td></tr> <tr><td></td><td>06</td></tr> <tr><td colspan="2"> </td></tr> <tr><td></td><td>61</td></tr> <tr><td></td><td>68</td></tr> <tr><td></td><td>69</td></tr> </tbody> </table>		FC		+24 V	12	+24 V	13	D IN	18	D IN	19	COM	20	D IN	27	D IN	29	D IN	32	D IN	33	D IN	37			+10V	50	A IN	53	A IN	54	COM	55	A OUT	42	COM	39			R1	01		02		03			R2	04		05		06				61		68		69	130BB685.10	Parameter 8-30 <i>Protocol</i> FC*
FC																																																															
+24 V	12																																																														
+24 V	13																																																														
D IN	18																																																														
D IN	19																																																														
COM	20																																																														
D IN	27																																																														
D IN	29																																																														
D IN	32																																																														
D IN	33																																																														
D IN	37																																																														
+10V	50																																																														
A IN	53																																																														
A IN	54																																																														
COM	55																																																														
A OUT	42																																																														
COM	39																																																														
R1	01																																																														
	02																																																														
	03																																																														
R2	04																																																														
	05																																																														
	06																																																														
	61																																																														
	68																																																														
	69																																																														
		Parameter 8-31 <i>Address</i> 1*																																																													
		Parameter 8-32 <i>Baud Rate</i> 9600*																																																													
		* = Default Value																																																													
		Notes/comments: Select protocol, address and baud rate in the above-mentioned parameters. D IN 37 is an option.																																																													

Table 6.11 RS485 Network Connection

6.2.6 Motor Thermistor

WARNING

THERMISTOR INSULATION

Risk of personal injury or equipment damage.

- Use only thermistors with reinforced or double insulation to meet PELV insulation requirements.

		Parameters																																											
		Function	Setting																																										
<table border="1"> <thead> <tr> <th colspan="2">VLT</th> </tr> </thead> <tbody> <tr><td>+24 V</td><td>12</td></tr> <tr><td>+24 V</td><td>13</td></tr> <tr><td>D IN</td><td>18</td></tr> <tr><td>D IN</td><td>19</td></tr> <tr><td>COM</td><td>20</td></tr> <tr><td>D IN</td><td>27</td></tr> <tr><td>D IN</td><td>29</td></tr> <tr><td>D IN</td><td>32</td></tr> <tr><td>D IN</td><td>33</td></tr> <tr><td>D IN</td><td>37</td></tr> <tr><td colspan="2"> </td></tr> <tr><td>+10 V</td><td>50</td></tr> <tr><td>A IN</td><td>53</td></tr> <tr><td>A IN</td><td>54</td></tr> <tr><td>COM</td><td>55</td></tr> <tr><td>A OUT</td><td>42</td></tr> <tr><td>COM</td><td>39</td></tr> <tr><td colspan="2"> </td></tr> <tr><td>U - I</td><td></td></tr> <tr><td>A53</td><td></td></tr> </tbody> </table>		VLT		+24 V	12	+24 V	13	D IN	18	D IN	19	COM	20	D IN	27	D IN	29	D IN	32	D IN	33	D IN	37			+10 V	50	A IN	53	A IN	54	COM	55	A OUT	42	COM	39			U - I		A53		130BB686.12	Parameter 1-90 <i>Motor Thermal Protection</i> [2] Thermistor trip
VLT																																													
+24 V	12																																												
+24 V	13																																												
D IN	18																																												
D IN	19																																												
COM	20																																												
D IN	27																																												
D IN	29																																												
D IN	32																																												
D IN	33																																												
D IN	37																																												
+10 V	50																																												
A IN	53																																												
A IN	54																																												
COM	55																																												
A OUT	42																																												
COM	39																																												
U - I																																													
A53																																													
		Parameter 1-93 T <i>hermistor Source</i> [1] Analog input 53																																											
		* = Default Value																																											
		Notes/comments: If only a warning is desired, parameter <i>parameter 1-90 Motor Thermal Protection</i> should be set to [1] Thermistor warning. D IN 37 is an option.																																											

Table 6.12 Motor Thermistor

6.2.7 SLC

FC		Parameters	
		Function	Setting
+24 V	12	Parameter 4-30 Motor Feedback Loss Function	[1] Warning
+24 V	13		
D IN	18		
D IN	19	Parameter 4-31 Motor Feedback Speed Error	100 RPM
COM	20		
D IN	27		
D IN	29	Parameter 4-32 Motor Feedback Loss Timeout	5 s
D IN	32		
D IN	33		
D IN	37		
+10 V	50	Parameter 7-00 Speed PID Feedback Source	[2] MCB 102
A IN	53		
A IN	54	Parameter 17-11 Resolution (PPR)	1024*
COM	55		
A OUT	42	Parameter 13-00 SL Controller Mode	[1] On
COM	39		
R1	01	Parameter 13-01 Start Event	[19] Warning
	02		
	03	Parameter 13-02 Stop Event	[44] Reset key
R2	04	Parameter 13-10 Comparator Operand	[21] Warning no.
	05		
	06	Parameter 13-11 Comparator Operator	[1] ≈*
		Parameter 13-12 Comparator Value	90
		Parameter 13-51 SL Controller Event	[22] Comparator 0
		Parameter 13-52 SL Controller Action	[32] Set digital out A low
		Parameter 5-40 Function Relay	[80] SL digital output A
		*=-Default Value	

Parameters	
Notes/comments:	
If the limit in the feedback monitor is exceeded, Alarm 90, Feedback monitor is issued. The SLC monitors Alarm 90, Feedback monitor and if becomes TRUE, relay 1 is triggered. External equipment may then indicate that service may be required. If the feedback error goes below the limit again within 5 s, the adjustable frequency drive continues and the warning disappears. But relay 1 is still triggered until pressing [Reset] on the LCP.	

Table 6.13 Using SLC to Set a Relay

6.2.8 Mechanical Brake Control

FC		Parameters	
		Function	Setting
+24 V	12	Parameter 5-40 Function Relay	[32] Mech. brake ctrl.
+24 V	13		
D IN	18	Parameter 5-10 Terminal 18 Digital Input	[8] Start*
D IN	19		
COM	20		
D IN	27	Parameter 5-11 Terminal 19 Digital Input	[11] Start reversing
D IN	29		
D IN	32		
D IN	33	Parameter 1-71 Start Delay	0.2
D IN	37	Parameter 1-72 Start Function	[5] VVC+/ FLUX Clockwise
+10 V	50	Parameter 1-76 Start Current	I _{m,n}
A IN	53		
A IN	54	Parameter 2-20 Release Brake Current	App. dependent
COM	55		
A OUT	42	Parameter 2-21 Activate Brake Speed [RPM]	Half of nominal slip of the motor
COM	39		
R1	01		
	02		
	03		
R2	04		
	05		
	06		
		*=-Default Value	
		Notes/comments:	

Table 6.14 Mechanical Brake Control (Open-loop)

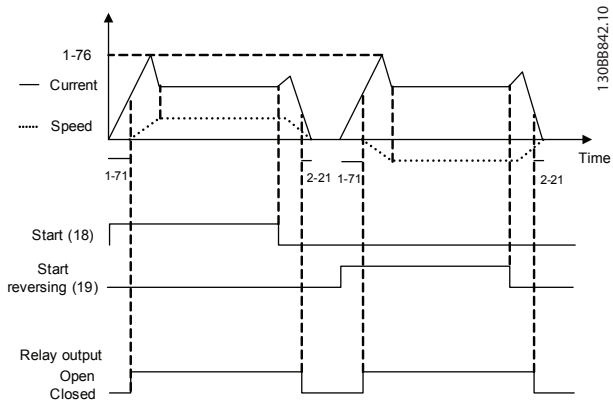

Figure 6.4 Mechanical Brake Control (Open-loop)

7 Maintenance, Diagnostics and Troubleshooting

This chapter includes maintenance and service guidelines, status messages, warnings and alarms, and basic troubleshooting.

7.1 Maintenance and Service

Under normal operating conditions and load profiles, the adjustable frequency drive is maintenance-free throughout its designed lifetime. To prevent breakdown, danger, and damage, examine the adjustable frequency drive at regular intervals depending on the operating conditions. Replace worn or damaged parts with original spare parts or standard parts. For service and support, refer to www.danfoss.com/contact/sales_and_services/.

⚠ WARNING

UNINTENDED START

When the adjustable frequency drive is connected to AC line power, DC supply, or load sharing, the motor may start at any time. Unintended start during programming, service, or repair work can result in death, serious injury, or property damage. The motor can start with an external switch, a serial communication bus command, an input reference signal from the LCP or LOP, via remote operation using MCT 10 Set-up Software, or after a cleared fault condition.

To prevent unintended motor start:

- Disconnect the adjustable frequency drive from line power.
- Press [Off/Reset] on the LCP before programming parameters.
- Completely wire and assemble the adjustable frequency drive, motor, and any driven equipment before connecting the adjustable frequency drive to AC line power, DC supply, or load sharing.

7.2 Heatsink Access Panel

7.2.1 Removing the Heatsink Access Panel

The adjustable frequency drive has an optional access panel for accessing the heatsink.

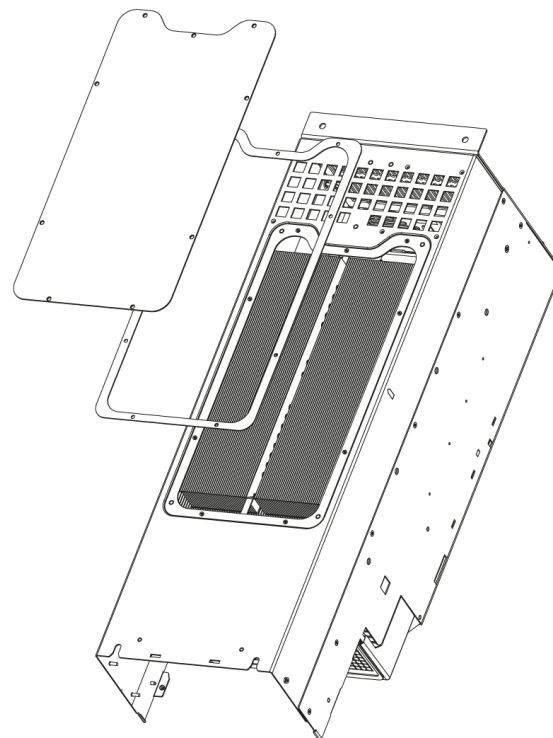

Figure 7.1 Heatsink Access Panel

1. Do not run the adjustable frequency drive during heatsink access panel removal.
2. If the adjustable frequency drive is mounted on a wall, or the back of it is otherwise inaccessible, reposition it so that the back is fully accessible.
3. Remove the screws (3 mm internal hex) connecting the access panel to the back of the enclosure. There are five or nine screws depending on the size of the adjustable frequency drive.

Reinstall in reverse order of this procedure and tighten fasteners according to *chapter 8.8 Connection Tightening Torques*.

7.3 Status Messages

When the adjustable frequency drive is in *Status mode*, status messages are generated automatically and appear in the bottom line of the display (see *Figure 7.2*).

130BD430.10

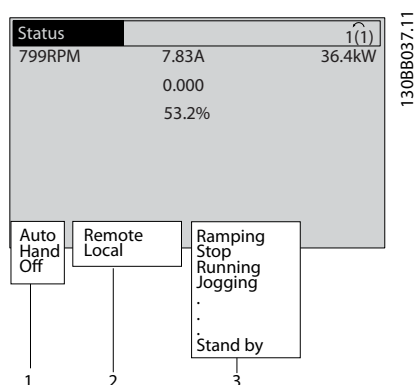

1	Operation mode (see Table 7.1)
2	Reference site (see Table 7.2)
3	Operation status (see Table 7.3)

Figure 7.2 Status Display

Table 7.1 to Table 7.3 describe the displayed status messages.

Off	The adjustable frequency drive does not react to any control signal until [Auto On] or [Hand On] is pressed.
Auto On	The adjustable frequency drive is controlled from the control terminals and/or the serial communication.
Hand On	The adjustable frequency drive is controlled by the navigation keys on the LCP. Stop commands, reset, reversing, DC brake, and other signals applied to the control terminals override local control.

Table 7.1 Operation Mode

Remote	The speed reference is given from external signals, serial communication, or internal preset references.
Local	The adjustable frequency drive uses [Hand On] control or reference values from the LCP.

Table 7.2 Reference Site

AC Brake	Parameter 2-16 AC Brake Max. Current was selected in parameter 2-10 Brake Function. The AC brake overmagnetizes the motor to achieve a controlled slow-down.
AMA finish OK	Automatic motor adaptation (AMA) was carried out successfully.
AMA ready	AMA is ready to start. Press [Hand On] to start.
AMA running	AMA process is in progress.

Braking	The brake chopper is in operation. Generative energy is absorbed by the brake resistor.
Braking max.	The brake chopper is in operation. The power limit for the brake resistor defined in parameter 2-12 Brake Power Limit (kW) has been reached.
Coast	<ul style="list-style-type: none"> Coast inverse was selected as a function for a digital input (parameter group 5-1* Digital Inputs). The corresponding terminal is not connected. Coast activated by serial communication.
Ctrl. ramp-down	<p>[1] Control Ramp-down was selected in parameter 14-10 Mains Failure.</p> <ul style="list-style-type: none"> The AC line voltage is below the value set in parameter 14-11 Mains Voltage at Mains Fault at line power fault . The adjustable frequency drive ramps down the motor using a controlled ramp-down.
Current High	The adjustable frequency drive output current is above the limit set in parameter 4-51 Warning Current High.
Current Low	The adjustable frequency drive output current is below the limit set in parameter 4-52 Warning Speed Low.
DC Hold	[1] DC hold is selected in parameter 1-80 Function at Stop and a stop command is active. The motor is held by a DC current set in parameter 2-00 DC Hold/Preheat Current.
DC Stop	<p>The motor is held with a DC current (parameter 2-01 DC Brake Current) for a specified time (parameter 2-02 DC Braking Time).</p> <ul style="list-style-type: none"> The DC Brake cut-in speed is reached in parameter 2-03 DC Brake Cut-in Speed [RPM] and a stop command is active. DC Brake (inverse) is selected as a function for a digital input (parameter group 5-1* Digital Inputs). The corresponding terminal is not active. The DC Brake is activated via serial communication.
Feedback high	The sum of all active feedbacks is above the feedback limit set in parameter 4-57 Warning Feedback High.
Feedback low	The sum of all active feedbacks is below the feedback limit set in parameter 4-56 Warning Feedback Low.

Freeze output	<p>The remote reference is active, which holds the present speed.</p> <ul style="list-style-type: none"> • <i>Freeze output</i> was selected as a function for a digital input (parameter group 5-1* <i>Digital Inputs</i>). The corresponding terminal is active. Speed control is only possible via the terminal functions <i>Speed Up</i> and <i>Slow</i>. • <i>Hold ramp</i> is activated via serial communication.
Freeze output request	A freeze output command was given but the motor remains stopped until a run permissive signal is received.
Freeze ref.	<i>Freeze Reference</i> was selected as a function for a digital input (parameter group 5-1* <i>Digital Inputs</i>). The corresponding terminal is active. The adjustable frequency drive saves the actual reference. Changing the reference is now only possible via terminal functions <i>Speed Up</i> and <i>Slow</i> .
Jog request	A jog command was given but the motor remains stopped until a run permissive signal is received via a digital input.
Jogging	<p>The motor is running as programmed in <i>parameter 3-19 Jog Speed [RPM]</i>.</p> <ul style="list-style-type: none"> • <i>Jog</i> was selected as a function for a digital input (parameter group 5-1* <i>Digital Inputs</i>). The corresponding terminal (for example Terminal 29) is active. • The <i>Jog</i> function is activated via the serial communication. • The <i>Jog</i> function was selected as a reaction for a monitoring function (for example. No signal). The monitoring function is active.
Motor check	In <i>parameter 1-80 Function at Stop, [2] Motor Check</i> was selected. A stop command is active. To ensure that a motor is connected to the adjustable frequency drive, a permanent test current is applied to the motor.
Over Voltage Control (OVC)	Overvoltage control was activated in <i>parameter 2-17 Over-voltage Control, [2] Enabled</i> . The connected motor supplies the adjustable frequency drive with generative energy. Overvoltage control adjusts the V/Hz ratio to run the motor in controlled mode and to prevent the adjustable frequency drive from tripping.
PowerUnit Off	(Only adjustable frequency drives with an external 24 V power supply installed). Line power supply to the adjustable frequency drive was removed, and the control card is supplied by the external 24 V.

Protection md	<p>Protection mode is active. The unit has detected a critical status (overcurrent or overvoltage).</p> <ul style="list-style-type: none"> • To avoid tripping, switching frequency is reduced to 4 kHz. • If possible, protection mode ends after approximately 10 s. • Protection mode can be restricted in <i>parameter 14-26 Trip Delay at Inverter Fault</i>.
QStop	<p>The motor is decelerating using <i>parameter 3-81 Quick Stop Ramp Time</i>.</p> <ul style="list-style-type: none"> • <i>Quick stop inverse</i> was selected as a function for a digital input (parameter group 5-1* <i>Digital Inputs</i>). The corresponding terminal is not active. • The <i>quick stop</i> function was activated via serial communication.
Ramping	The motor is accelerating/decelerating using the active ramp-up/down. The reference, a limit value, or a standstill is not yet reached.
Ref. high	The sum of all active references is above the reference limit set in <i>parameter 4-55 Warning Reference High</i> .
Ref. low	The sum of all active references is below the reference limit set in <i>parameter 4-54 Warning Reference Low</i> .
Run on ref.	The adjustable frequency drive is running in the reference range. The feedback value matches the setpoint value.
Run request	A start command was given but the motor remains stopped until a run permissive signal is received via digital input.
Running	The adjustable frequency drive drives the motor.
Sleep Mode	The energy-saving function is enabled. The motor has stopped but restarts automatically when required.
Speed high	Motor speed is above the value set in <i>parameter 4-53 Warning Speed High</i> .
Speed low	Motor speed is below the value set in <i>parameter 4-52 Warning Speed Low</i> .
Standby	In <i>Auto On</i> mode, the adjustable frequency drive starts the motor with a start signal from a digital input or serial communication.
Start delay	In <i>parameter 1-71 Start Delay</i> , a delay starting time was set. A start command is activated and the motor starts after the start delay time expires.

Start fwd/rev	Start forward and start reverse were selected as functions for two different digital inputs (parameter group 5-1* Digital Inputs). The motor starts in forward or reverse direction depending on which corresponding terminal is activated.
Stop	The adjustable frequency drive has received a stop command from the LCP, digital input or serial communication.
Trip	An alarm occurred and the motor is stopped. Once the cause of the alarm is cleared, the adjustable frequency drive can be reset manually by pressing [Reset] or remotely by control terminals or serial communication.
Trip lock	An alarm occurred and the motor is stopped. Once the cause of the alarm is cleared, cycle power to the adjustable frequency drive. The adjustable frequency drive can then be reset manually by pressing [Reset], or remotely by control terminals or serial communication.

Table 7.3 Operation Status

NOTICE!

In auto/remote mode, the adjustable frequency drive requires external commands to execute functions.

7.4 Warning and Alarm Types

Warnings

A warning is issued when an alarm condition is impending or when an abnormal operating condition is present and may result in the adjustable frequency drive issuing an alarm. A warning clears by itself when the abnormal condition ceases.

Alarms

Trip

An alarm is issued when the adjustable frequency drive is tripped, meaning that the adjustable frequency drive suspends operation to prevent adjustable frequency drive or system damage. The motor coasts to a stop. The adjustable frequency drive logic continues to operate and monitor the adjustable frequency drive status. After the fault condition is remedied, the adjustable frequency drive can be reset. It is then ready to restart operation.

Resetting the adjustable frequency drive after trip/trip lock

A trip can be reset in any of four ways:

- Press [Reset] on the LCP.
- Digital reset input command.
- Serial communication reset input command.
- Auto reset.

Trip lock

Input power is cycled. The motor coasts to a stop. The adjustable frequency drive continues to monitor the adjustable frequency drive status. Remove input power to the adjustable frequency drive, correct the cause of the fault, and reset the adjustable frequency drive.

Warning and alarm displays

- A warning is displayed in the LCP along with the warning number.
- An alarm flashes along with the alarm number.

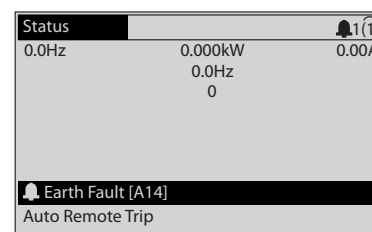
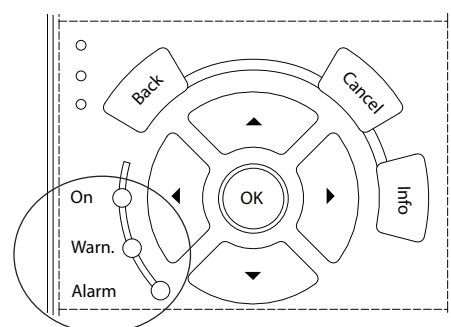

Figure 7.3 Alarm Display Example

In addition to the text and alarm code in the LCP, there are three status indicator lights (LEDs).



	Warning LED	Alarm LED
Warning	On	Off
Alarm	Off	On (flashing)
Trip Lock	On	On (flashing)

Figure 7.4 Status Indicator Lights (LEDs)

7.5 List of Warnings and Alarms

The following warning/alarm information defines each warning/alarm condition, provides the probable cause for the condition, and details a remedy or troubleshooting procedure.

WARNING 1, 10 Volts low

The control card voltage is less than 10 V from terminal 50. Remove some of the load from terminal 50, as the 10 V supply is overloaded. Maximum 15 mA or minimum 590 Ω.

A short circuit in a connected potentiometer or incorrect wiring of the potentiometer can cause this condition.

Troubleshooting

- Remove the wiring from terminal 50. If the warning clears, the problem is with the wiring. If the warning does not clear, replace the control card.

WARNING/ALARM 2, Live zero error

This warning or alarm only appears if programmed in *parameter 6-01 Live Zero Timeout Function*. The signal on one of the analog inputs is less than 50% of the minimum value programmed for that input. Broken wiring or a faulty device sending the signal can cause this condition.

Troubleshooting

- Check the connections on all the analog line power terminals.
 - Control card terminals 53 and 54 for signals, terminal 55 common.
 - VLT® General Purpose I/O MCB 101 terminals 11 and 12 for signals, terminal 10 common.
 - VLT® Analog I/O Option MCB 109 terminals 1, 3, and 5 for signals, terminals 2, 4, and 6 common.
- Check that the adjustable frequency drive programming and switch settings match the analog signal type.
- Perform an input terminal signal test.

WARNING/ALARM 3, No motor

No motor is connected to the output of the adjustable frequency drive.

WARNING/ALARM 4, Mains phase loss

A phase is missing on the supply side, or the line voltage imbalance is too high. This message also appears for a fault in the input rectifier on the adjustable frequency drive. Options are programmed in *parameter 14-12 Function at Mains Imbalance*.

Troubleshooting

- Check the supply voltage and supply currents to the adjustable frequency drive.

WARNING 5, DC link voltage high

The DC link voltage (DC) is higher than the high-voltage warning limit. The limit depends on the adjustable frequency drive voltage rating. The unit is still active.

WARNING 6, DC link voltage low

The DC link voltage (DC) is lower than the low-voltage warning limit. The limit depends on the adjustable frequency drive voltage rating. The unit is still active.

WARNING/ALARM 7, DC overvoltage

If the intermediate circuit voltage exceeds the limit, the adjustable frequency drive trips after a time.

Troubleshooting

- Connect a brake resistor.
- Extend the ramp time.
- Change the ramp type.
- Activate the functions in *parameter 2-10 Brake Function*.
- Increase *parameter 14-26 Trip Delay at Inverter Fault*.
- If the alarm/warning occurs during a power sag, use kinetic backup (*parameter 14-10 Line Failure*).

WARNING/ALARM 8, DC undervoltage

If the DC link voltage drops below the undervoltage limit, the adjustable frequency drive checks if a 24 V DC backup supply is connected. If no 24 V DC backup supply is connected, the adjustable frequency drive trips after a fixed time delay. The time delay varies with unit size.

Troubleshooting

- Make sure that the supply voltage matches the adjustable frequency drive voltage.
- Perform an input voltage test.
- Perform a soft charge circuit test.

WARNING/ALARM 9, Inverter overload

The adjustable frequency drive has run with more than 100% overload for too long and is about to cut out. The counter for electronic thermal inverter protection issues a warning at 98% and trips at 100%, while giving an alarm. The adjustable frequency drive cannot be reset until the counter is below 90%.

Troubleshooting

- Compare the output current shown on the LCP with the adjustable frequency drive rated current.
- Compare the output current shown on the LCP with the measured motor current.
- Display the thermal drive load on the LCP and monitor the value. When running above the adjustable frequency drive continuous current rating, the counter increases. When running below the adjustable frequency drive continuous current rating, the counter decreases.

WARNING/ALARM 10, Motor overload temperature

According to the electronic thermal protection (ETR), the motor is too hot. Select whether the adjustable frequency drive issues a warning or an alarm when the counter reaches 100% in *parameter 1-90 Motor Thermal Protection*.

The fault occurs when the motor runs with more than 100% overload for too long.

Troubleshooting

- Check for motor overheating.
- Check if the motor is mechanically overloaded.
- Check that the motor current set in *parameter 1-24 Motor Current* is correct.
- Ensure that the motor data in *parameters 1-20 to 1-25* are set correctly.
- If an external fan is in use, check that it is selected in *parameter 1-91 Motor External Fan*.
- Running AMA in *parameter 1-29 Automatic Motor Adaptation (AMA)* tunes the adjustable frequency drive to the motor more accurately and reduces thermal loading.

WARNING/ALARM 11, Motor thermistor overtemp

Check whether the thermistor is disconnected. Select whether the adjustable frequency drive issues a warning or an alarm in *parameter 1-90 Motor Thermal Protection*.

Troubleshooting

- Check for motor overheating.
- Check if the motor is mechanically overloaded.
- When using terminal 53 or 54, check that the thermistor is connected correctly between either terminal 53 or 54 (analog voltage input) and terminal 50 (+10 V supply). Also check that the terminal switch for 53 or 54 is set for voltage. Check that *parameter 1-93 Thermistor Source* selects terminal 53 or 54.
- When using digital inputs 18 or 19, check that the thermistor is connected correctly between either terminal 18 or 19 (digital input PNP only) and terminal 50. Check that *parameter 1-93 Thermistor Source* selects terminal 18 or 19.

WARNING/ALARM 12, Torque limit

The torque has exceeded the value in *parameter 4-16 Torque Limit Motor Mode* or the value in *parameter 4-17 Torque Limit Generator Mode*. *Parameter 14-25 Trip Delay at Torque Limit* can change this warning from a warning-only condition to a warning followed by an alarm.

Troubleshooting

- If the motor torque limit is exceeded during ramp-up, extend the ramp-up time.
- If the generator torque limit is exceeded during ramp-down, extend the ramp-down time.

- If torque limit occurs while running, increase the torque limit. Make sure that the system can operate safely at a higher torque.
- Check the application for excessive current draw on the motor.

WARNING/ALARM 13, Overcurrent

The inverter peak current limit (approximately 200% of the rated current) is exceeded. The warning lasts approximately 1.5 s, then the adjustable frequency drive trips and issues an alarm. Shock loading or quick acceleration with high-inertia loads can cause this fault. If the acceleration during ramp-up is quick, the fault can also appear after kinetic backup.

If extended mechanical brake control is selected, a trip can be reset externally.

Troubleshooting

- Remove the power and check if the motor shaft can be turned.
- Make sure that the motor size matches the adjustable frequency drive.
- Check that the motor data is correct in *parameters 1-20 to 1-25*.

ALARM 14, Ground fault

There is current from the output phases to ground, either in the cable between the adjustable frequency drive and the motor or in the motor itself.

Troubleshooting

- Remove power to the adjustable frequency drive and repair the ground fault.
- Check for ground faults in the motor by measuring the resistance to ground of the motor leads and the motor with a megohmmeter.

ALARM 15, Hardware mismatch

A fitted option is not operational with the present control board hardware or software.

Record the value of the following parameters and contact Danfoss:

- *Parameter 15-40 FC Type*
- *Parameter 15-41 Power Section*
- *Parameter 15-42 Voltage*
- *Parameter 15-43 Software Version*
- *Parameter 15-45 Actual Typecode String*
- *Parameter 15-49 SW ID Control Card*
- *Parameter 15-50 SW ID Power Card*
- *Parameter 15-60 Option Mounted*
- *Parameter 15-61 Option SW Version* (for each option slot)

ALARM 16, Short circuit

There is short-circuiting in the motor or motor wiring.

Troubleshooting

- Remove the power to the adjustable frequency drive and repair the short circuit.

WARNING/ALARM 17, Control word timeout

There is no communication to the adjustable frequency drive.

The warning is only active when *parameter 8-04 Control Word Timeout Function* is NOT set to [0] Off.

If *parameter 8-04 Control Word Timeout Function* is set to [5] Stop and Trip, a warning appears and the adjustable frequency drive ramps down until it stops, and then it displays an alarm.

Troubleshooting

- Check the connections on the serial communication cable.
- Increase *parameter 8-03 Control Word Timeout Time*.
- Check the operation of the communication equipment.
- Verify a proper installation based on EMC requirements.

WARNING/ALARM 20, Temp. input error

The temperature sensor is not connected.

WARNING/ALARM 21, Parameter error

The parameter is out of range. The parameter number is reported in the display.

Troubleshooting

- Set the affected parameter to a valid value.

WARNING/ALARM 22, Hoist mechanical brake

Report value shows what kind it is.

0 = The torque reference was not reached before timeout (*parameter 2-27 Torque Ramp Up Time*).

1 = Expected brake feedback not received before timeout (*parameter 2-23 Activate Brake Delay, parameter 2-25 Brake Release Time*).

WARNING 23, Internal fan fault

The fan warning function is an extra protective function that checks if the fan is running/mounted. The fan warning can be disabled in *parameter 14-53 Fan Monitor* ([0] Disabled).

For adjustable frequency drives with DC fans, there is a feedback sensor mounted in the fan. If the fan is commanded to run and there is no feedback from the sensor, this alarm appears. For adjustable frequency drives with AC fans, the voltage to the fan is monitored.

Troubleshooting

- Check for proper fan operation.
- Cycle power to the adjustable frequency drive and check that the fan operates briefly at start-up.
- Check the sensors on the heatsink and control card.

WARNING 24, External fan fault

The fan warning function is an extra protective function that checks if the fan is running/mounted. The fan warning can be disabled in *parameter 14-53 Fan Monitor* ([0] Disabled).

For adjustable frequency drives with DC fans, there is a feedback sensor mounted in the fan. If the fan is commanded to run and there is no feedback from the sensor, this alarm appears. For adjustable frequency drives with AC fans, the voltage to the fan is monitored.

Troubleshooting

- Check for proper fan operation.
- Cycle power to the adjustable frequency drive and check that the fan operates briefly at start-up.
- Check the sensors on the heatsink and control card.

WARNING 25, Brake resistor short circuit

The brake resistor is monitored during operation. If a short circuit occurs, the brake function is disabled and the warning appears. The adjustable frequency drive is still operational but without the brake function.

Troubleshooting

- Remove the power to the adjustable frequency drive and replace the brake resistor (see *parameter 2-15 Brake Check*).

WARNING/ALARM 26, Brake resistor power limit

The power transmitted to the brake resistor is calculated as a mean value over the last 120 s of run time. The calculation is based on the DC link voltage and the brake resistor value set in *parameter 2-16 AC Brake Max. Current*. The warning is active when the dissipated braking energy is higher than 90% of the brake resistor power. If option [2] Trip is selected in *parameter 2-13 Brake Power Monitoring*, the adjustable frequency drive trips when the dissipated braking energy reaches 100%.

WARNING/ALARM 27, Brake chopper fault

The brake transistor is monitored during operation, and if a short circuit occurs, the brake function is disabled and a warning is issued. The adjustable frequency drive is still operational but, since the brake transistor has short-circuited, substantial power is transmitted to the brake resistor, even if it is inactive.

Troubleshooting

- Remove power to the adjustable frequency drive and remove the brake resistor.

WARNING/ALARM 28, Brake check failed

The brake resistor is not connected or not working. Check *parameter 2-15 Brake Check*.

ALARM 30, Motor phase U missing

Motor phase U between the adjustable frequency drive and the motor is missing.

Troubleshooting

- Remove the power from the adjustable frequency drive and check motor phase U.

ALARM 31, Motor phase V missing

Motor phase V between the adjustable frequency drive and the motor is missing.

Troubleshooting

- Remove the power from the adjustable frequency drive and check motor phase V.

ALARM 32, Motor phase W missing

Motor phase W between the adjustable frequency drive and the motor is missing.

Troubleshooting

- Remove the power from the adjustable frequency drive and check motor phase W.

ALARM 33, Inrush fault

Too many power-ups have occurred within a short time period.

Troubleshooting

- Let the unit cool to operating temperature.

WARNING/ALARM 34, Fieldbus communication fault

The serial communication bus on the communication option card is not working.

WARNING/ALARM 35, Option fault

An option alarm is received. The alarm is option-specific. The most likely cause is a power-up or a communication fault.

WARNING/ALARM 36, Mains failure

This warning/alarm is only active if the supply voltage to the adjustable frequency drive is lost and *parameter 14-10 Mains Failure* is not set to option [0] *No Function*. Check the fuses to the adjustable frequency drive and line power supply to the unit.

ALARM 37, Phase imbalance

There is a current imbalance between the power units.

ALARM 38, Internal fault

When an internal fault occurs, a code number defined in *Table 7.4* is displayed.

Troubleshooting

- Cycle power.
- Check that the option is properly installed.
- Check for loose or missing wiring.

It may be necessary to contact the Danfoss supplier or service department. Note the code number for further troubleshooting directions.

Number	Text
0	The serial port cannot be initialized. Contact the Danfoss supplier or Danfoss Service Department.
256–258	The power EEPROM data is defective or too old. Replace the power card.
512–519	Internal fault. Contact the Danfoss supplier or Danfoss Service Department.
783	Parameter value outside of minimum/maximum limits.
1024–1284	Internal fault. Contact the Danfoss supplier or the Danfoss Service Department.
1299	The option software in slot A is too old.
1300	The option software in slot B is too old.
1302	The option software in slot C1 is too old.
1315	The option software in slot A is not supported (not allowed).
1316	The option software in slot B is not supported (not allowed).
1318	The option software in slot C1 is not supported (not allowed).
1379–2819	Internal fault. Contact the Danfoss supplier or Danfoss Service Department.
1792	HW reset of DSP.
1793	Motor-derived parameters not transferred correctly to the DSP.
1794	Power data not transferred correctly at power-up to the DSP.
1795	The DSP has received too many unknown SPI messages. The adjustable frequency drive also uses this fault code if the MCO does not power up correctly, for example, due to poor EMC protection or improper grounding.
1796	RAM copy error.
2561	Replace the control card.
2820	LCP stack overflow.
2821	Serial port overflow.
2822	USB port overflow.
3072–5122	Parameter value is outside its limits.
5123	Option in slot A: Hardware incompatible with the control board hardware.
5124	Option in slot B: Hardware incompatible with the control board hardware.

Number	Text
5125	Option in slot C0: Hardware incompatible with the control board hardware.
5126	Option in slot C1: Hardware incompatible with the control board hardware.
5376–6231	Internal fault. Contact the Danfoss supplier or Danfoss Service Department.

Table 7.4 Internal Fault Codes

ALARM 39, Heatsink sensor

No feedback from the heatsink temperature sensor.

The signal from the IGBT thermal sensor is not available on the power card. The problem could be on the power card, on the gate drive card, or the ribbon cable between the power card and gate drive card.

WARNING 40, Overload of digital output terminal 27

Check the load connected to terminal 27 or remove the short-circuit connection. Check *parameter 5-00 Digital I/O Mode* and *parameter 5-01 Terminal 27 Mode*.

WARNING 41, Overload of digital output terminal 29

Check the load connected to terminal 29 or remove the short-circuit connection. Check *parameter 5-00 Digital I/O Mode* and *parameter 5-02 Terminal 29 Mode*.

WARNING 42, Overload of digital output on X30/6 or overload of digital output on X30/7

For terminal X30/6, check the load connected to terminal X30/6 or remove the short circuit connection. Check *parameter 5-32 Term X30/6 Digi Out (MCB 101)*.

For terminal X30/7, check the load connected to terminal X30/7 or remove the short circuit connection. Check *parameter 5-33 Term X30/7 Digi Out (MCB 101)*.

ALARM 43, Ext. supply

MCB 113 Ext. Relay Option is mounted without external 24 V DC. Either connect an ext. 24 V DC supply or specify that no external supply is used via *parameter 14-80 Option Supplied by External 24VDC [0] No*. A change in *parameter 14-80 Option Supplied by External 24VDC* requires a power cycle.

ALARM 45, Ground fault 2

Ground fault.

Troubleshooting

- Check for proper grounding and loose connections.
- Check for proper wire size.
- Check the motor cables for short circuits or leakage currents.

ALARM 46, Power card supply

The supply on the power card is out of range. There are three supplies generated by the switch mode supply (SMPS) on the power card:

- 24 V
- 5 V
- ± 18 V

When powered with 24 V DC with VLT® 24 V DC Supply MCB 107, only the 24 V and 5 V supplies are monitored. When powered with three-phase AC line voltage, all three supplies are monitored.

Troubleshooting

- Check for a defective power card.
- Check for a defective control card.
- Check for a defective option card.
- If a 24 V DC supply is used, verify proper supply power.

WARNING 47, 24 V supply low

The supply on the power card is out of range. There are three supplies generated by the switch mode supply (SMPS) on the power card:

- 24 V
- 5 V
- ± 18 V

Troubleshooting

- Check for a defective power card.

WARNING 48, 1.8 V supply low

The 1.8 V DC supply used on the control card is outside of the allowable limits. The supply is measured on the control card. Check for a defective control card. If an option card is present, check for overvoltage.

WARNING 49, Speed limit

When the speed is outside of the specified range in *parameter 4-11 Motor Speed Low Limit [RPM]* and *parameter 4-13 Motor Speed High Limit [RPM]*, the adjustable frequency drive shows a warning. When the speed is below the specified limit in *parameter 1-86 Trip Speed Low [RPM]* (except when starting or stopping), the adjustable frequency drive trips.

ALARM 50, AMA calibration failed

Contact the Danfoss supplier or Danfoss Service Department.

ALARM 51, AMA check U_{nom} and I_{nom}

The settings for motor voltage, motor current, and motor power are wrong. Check the settings in *parameters 1–20 to 1–25*.

ALARM 52, AMA low I_{nom}

The motor current is too low. Check the settings in *parameter 4-18 Current Limit*.

ALARM 53, AMA motor too big

The motor is too large for the AMA to operate.

ALARM 54, AMA motor too small

The motor is too small for the AMA to operate.

ALARM 55, AMA parameter out of range

The parameter values of the motor are outside of the acceptable range. AMA cannot run.

ALARM 56, AMA interrupted by user

The user has interrupted AMA.

ALARM 57, AMA internal fault

Try to restart AMA. Repeated restarts can overheat the motor.

ALARM 58, AMA Internal fault

Contact the Danfoss supplier.

WARNING 59, Current limit

The current is higher than the value in *parameter 4-18 Current Limit*. Ensure that motor data in *parameters 1-20 to 1-25* are set correctly. Increase the current limit if necessary. Ensure that the system can operate safely at a higher limit.

WARNING 60, External interlock

A digital input signal is indicating a fault condition externally to the adjustable frequency drive. An external interlock has commanded the adjustable frequency drive to trip. Clear the external fault condition. To resume normal operation, apply 24 V DC to the terminal programmed for external interlock. Reset the adjustable frequency drive.

WARNING/ALARM 61, Feedback error

An error between the calculated speed and speed measurement from the feedback device. The function Warning/Alarm/Disabling setting is in *parameter 4-30 Motor Feedback Loss Function*. Accepted error setting in *parameter 4-31 Motor Feedback Speed Error* and the allowed time the error occur setting in *parameter 4-32 Motor Feedback Loss Timeout*. During a commissioning procedure the function may be effective.

WARNING 62, Output frequency at maximum limit

The output frequency has reached the value set in *parameter 4-19 Max Output Frequency*. Check the application for possible causes. Possibly increase the output frequency limit. Be sure that the system can operate safely at a higher output frequency. The warning clears when the output drops below the maximum limit.

ALARM 63, Mechanical brake low

The actual motor current has not exceeded the release brake current within the start delay time window.

ALARM 64, Voltage Limit

The load and speed combination demands a motor voltage higher than the actual DC link voltage.

WARNING/ALARM 65, Control card overtemperature

The cut-out temperature of the control card is 176°F [80°C].

Troubleshooting

- Check that the ambient operating temperature is within the limits.
- Check for clogged filters.
- Check the fan operation.
- Check the control card.

WARNING 66, Heatsink temperature low

The adjustable frequency drive is too cold to operate. This warning is based on the temperature sensor in the IGBT module.

Increase the ambient temperature of the unit. Also, a trickle amount of current can be supplied to the adjustable frequency drive whenever the motor is stopped by setting *parameter 2-00 DC Hold/Preheat Current* at 5% and *parameter 1-80 Function at Stop*.

ALARM 67, Option module configuration has changed

One or more options have either been added or removed since the last power-down. Check that the configuration change is intentional and reset the unit.

ALARM 68, Safe Stop activated

STO has been activated. To resume normal operation, apply 24 V DC to terminal 37, then send a reset signal (via bus, digital I/O, or by pressing [Reset]).

ALARM 69, Power card temperature

The temperature sensor on the power card is either too hot or too cold.

Troubleshooting

- Check that the ambient operating temperature is within limits.
- Check for clogged filters.
- Check fan operation.
- Check the power card.

ALARM 70, Illegal FC configuration

The control card and power card are incompatible. To check compatibility, contact the Danfoss supplier with the type code of the unit from the nameplate and the part numbers of the cards.

ALARM 71, PTC 1 safe stop

STO has been activated from the VLT® PTC Thermistor Card MCB 112 (motor too warm). Normal operation can be resumed when the MCB 112 applies 24 V DC to terminal 37 again (when the motor temperature reaches an acceptable level) and when the digital input from the MCB

112 is deactivated. When that happens, send a reset signal (via bus or digital I/O, or press [Reset]).

ALARM 72, Dangerous failure

STO with trip lock. An unexpected combination of STO commands has occurred:

- VLT PTC Thermistor Card enables X44/10, but STO is not enabled.
- MCB 112 is the only device using STO (specified through selection [4] PTC 1 Alarm or [5] PTC 1 Warning in parameter 5-19 Terminal 37 Safe Stop), STO is activated, and X44/10 is not activated.

WARNING 73, Safe Stop auto restart

Safe Torque Off activated. With automatic restart enabled, the motor can start when the fault is cleared.

ALARM 74, PTC Thermistor

Alarm related to VLT® PTC Thermistor Card MCB 112. The PTC is not working.

ALARM 75, Illegal profile sel.

Parameter value must not be written while motor is running. Stop motor before writing MCO profile to parameter 8-10 Control Word Profile.

WARNING 76, Power unit set-up

The required number of power units does not match the detected number of active power units.

Troubleshooting

When replacing an F-frame module, this warning occurs, if the power-specific data in the module power card does not match the rest of the adjustable frequency drive. Confirm that the spare part and its power card are the correct part number.

WARNING 77, Reduced power mode

The adjustable frequency drive is operating in reduced power mode (less than the allowed number of inverter sections). This warning is generated on power cycle when the adjustable frequency drive is set to run with fewer inverters and remains on.

ALARM 78, Tracking error

The difference between the setpoint value and the actual value has exceeded the value in parameter 4-35 Tracking Error. Disable the function or select an alarm/warning in parameter 4-34 Tracking Error Function. Investigate the mechanics around the load and motor, check feedback connections from motor encoder to adjustable frequency drive. Select motor feedback function in parameter 4-30 Motor Feedback Loss Function. Adjust tracking error band in parameter 4-35 Tracking Error and parameter 4-37 Tracking Error Ramping.

ALARM 79, Illegal power section configuration

The scaling card has an incorrect part number or is not installed. The MK102 connector on the power card could not be installed.

ALARM 80, Drive initialized to default value

Parameter settings are initialized to default settings after a manual reset. To clear the alarm, reset the unit.

ALARM 81, CSIV corrupt

CSIV file has syntax errors.

ALARM 82, CSIV parameter error

CSIV failed to initialize a parameter.

ALARM 83, Illegal option combination

The mounted options are incompatible.

ALARM 84, No safety option

The safety option was removed without applying a general reset. Reconnect the safety option.

ALARM 88, Option detection

A change in the option layout was detected. Parameter 14-89 Option Detection is set to [0] Frozen configuration and the option layout has been changed.

- To apply the change, enable option layout changes in parameter 14-89 Option Detection.
- Alternatively, restore the correct option configuration.

WARNING 89, Mechanical brake sliding

The hoist brake monitor detects a motor speed exceeding 10 RPM.

ALARM 90, Feedback monitor

Check the connection to encoder/resolver option and, if necessary, replace VLT® Encoder Input MCB 102 or VLT® Resolver Input MCB 103.

ALARM 91, Analog input 54 wrong settings

Set switch S202 in position OFF (voltage input) when a KTY sensor is connected to analog input terminal 54.

ALARM 99, Locked rotor

Rotor is blocked.

WARNING/ALARM 104, Mixing fan fault

The fan is not operating. The fan monitor checks that the fan is spinning at power-up or whenever the mixing fan is turned on. The mixing fan fault can be configured as a warning or an alarm trip in parameter 14-53 Fan Monitor.

Troubleshooting

- Cycle power to the adjustable frequency drive to determine if the warning/alarm returns.

WARNING/ALARM 122, Mot. rotat. unexp.

The adjustable frequency drive performs a function that requires the motor to be at standstill, for example, DC hold for PM motors.

WARNING 163, ATEX ETR cur.lim.warning

The adjustable frequency drive has run above the characteristic curve for more than 50 s. The warning is activated at 83% and deactivated at 65% of the permitted thermal overload.

ALARM 164, ATEX ETR cur.lim.alarm

Operating above the characteristic curve for more than 60 s within a period of 600 s activates the alarm, and the adjustable frequency drive trips.

WARNING 165, ATEX ETR freq.lim.warning

The adjustable frequency drive is running more than 50 s below the permitted minimum frequency (*parameter 1-98 ATEX ETR interpol. points freq.*).

ALARM 166, ATEX ETR freq.lim.alarm

The adjustable frequency drive has operated for more than 60 s (in a period of 600 s) below the permitted minimum frequency (*parameter 1-98 ATEX ETR interpol. points freq.*).

ALARM 244, Heatsink temperature

This alarm is only for enclosure type F adjustable frequency drives. It is equivalent to Alarm 29. The report value in the alarm log indicates which power module generated the alarm:

- 1 = Left most inverter module.
- 2 = Middle inverter module in enclosure size F12 or F13.
- 2 = Right inverter module in enclosure size F10 or F11.

2 = Second adjustable frequency drive from the left inverter module in enclosure size F14 or F15.

3 = Right inverter module in enclosure sizes F12 or F13.

3 = Third from the left inverter module in enclosure size F14 or F15.

4 = Far right inverter module in enclosure sizes F14 or F15.

5 = Rectifier module.

6 = Right rectifier module in enclosure sizes F14 or F15.

WARNING 251, New typecode

The power card or other components have been replaced and the type code has been changed.

Troubleshooting

- Reset to remove the warning and resume normal operation.

WARNING 250, New spare part

A component in the adjustable frequency drive has been replaced.

Troubleshooting

- Reset the adjustable frequency drive for normal operation.

7.6 Troubleshooting

Symptom	Possible cause	Test	Solution
Display dark/No function	Missing input power.	See <i>Table 4.3</i> .	Check the input power source.
	Missing or open fuses, or circuit breaker tripped.	See <i>open power fuses and tripped circuit breaker</i> in this table for possible causes.	Follow the recommendations provided.
	No power to the LCP.	Check the LCP cable for proper connection or damage.	Replace the faulty LCP or connection cable.
	Shortcut on control voltage (terminal 12 or 50) or at control terminals.	Check the 24 V control voltage supply for terminal 12/13 to 20–39 or 10 V supply for terminal 50 to 55.	Wire the terminals properly.
	Incompatible LCP (LCP from VLT® 2800 or 5000/6000/8000/ FCD or FCM).		Use only LCP 101 (P/N 130B1124) or LCP 102 (P/N. 130B1107).
	Wrong contrast setting.		Press [Status] + [▲]/[▼] to adjust the contrast.
	Display (LCP) is defective.	Test using a different LCP.	Replace the faulty LCP or connection cable.
	Internal voltage supply fault or SMPS is defective.		Contact supplier.

Symptom	Possible cause	Test	Solution
Intermittent display	Overloaded power supply (SMPS) due to improper control wiring or a fault within the adjustable frequency drive.	To rule out a problem in the control wiring, disconnect all control wiring by removing the terminal blocks.	If the display stays lit, the problem is in the control wiring. Check the wiring for shorts or incorrect connections. If the display continues to cut out, follow the procedure for <i>Display dark\No function</i> .
Motor not running	Service switch open or missing motor connection.	Check if the motor is connected and the connection is not interrupted (by a service switch or other device).	Connect the motor and check the service switch.
	No line power with 24 V DC option card.	If the display is functioning, but there is no output, check that line power is applied to the adjustable frequency drive.	Apply line power to run the unit.
	LCP Stop.	Check if [Off] has been pressed.	Press [Auto On] or [Hand On] (depending on operation mode) to run the motor.
	Missing start signal (Standby).	Check <i>parameter 5-10 Terminal 18 Digital Input</i> for correct setting for terminal 18 (use default setting).	Apply a valid start signal to start the motor.
	Motor coast signal active (Coasting).	Check <i>parameter 5-12 Terminal 27 Digital Input</i> for correct setting for terminal 27 (use default setting).	Apply 24 V on terminal 27 or program this terminal to No operation.
	Wrong reference signal source.	Check reference signal: <ul style="list-style-type: none"> • Local • remote or bus reference? • Preset reference active? • Terminal connection correct? • Scaling of terminals correct? • Reference signal available? 	Program correct settings. Check <i>parameter 3-13 Reference Site</i> . Set preset reference active in parameter group 3-1* <i>References</i> . Check for correct wiring. Check scaling of terminals. Check reference signal.
Motor running in wrong direction	Motor rotation limit.	Check that <i>parameter 4-10 Motor Speed Direction</i> is programmed correctly.	Program correct settings.
	Active reversing signal.	Check if a reversing command is programmed for the terminal in parameter group 5-1* <i>Digital inputs</i> .	Deactivate reversing signal.
	Wrong motor phase connection.		See <i>chapter 5.5 Checking Motor Rotation</i> .
Motor is not reaching maximum speed	Frequency limits set wrong.	Check output limits in <i>parameter 4-13 Motor Speed High Limit [RPM]</i> , <i>parameter 4-14 Motor Speed High Limit [Hz]</i> , and <i>parameter 4-19 Max Output Frequency</i>	Program correct limits.
	Reference input signal not scaled correctly.	Check reference input signal scaling in parameter group 6-0* <i>Analog I/O mode</i> and parameter group 3-1* <i>References</i> .	Program correct settings.
Motor speed unstable	Possible incorrect parameter settings.	Check the settings of all motor parameters, including all motor compensation settings. For closed-loop operation, check PID settings.	Check settings in parameter group 1-6* <i>Load Depen. Setting</i> . For closed-loop operation, check settings in parameter group 20-0* <i>Feedback</i> .
Motor runs rough	Possible overmagnetization.	Check for incorrect motor settings in all motor parameters.	Check motor settings in parameter groups 1-2* <i>Motor data</i> 1-3* <i>Adv Motor Data</i> , and 1-5* <i>Load Indep. Setting</i> .
Motor does not brake	Possible incorrect settings in the brake parameters. Possible too short ramp-down times.	Check brake parameters. Check ramp time settings.	Check parameter group 2-0* <i>DC Brake</i> and 3-0* <i>Reference Limits</i> .

Symptom	Possible cause	Test	Solution
Open power fuses or circuit breaker trip	Phase-to-phase short.	Motor or panel has a short phase-to-phase. Check motor and panel phases for shorts.	Eliminate any shorts detected.
	Motor overload.	Motor is overloaded for the application.	Perform start-up test and verify that motor current is within specifications. If motor current is exceeding the nameplate full load current, the motor may run only with reduced load. Review the specifications for the application.
	Loose connections.	Perform pre-start-up check for loose connections.	Tighten loose connections.
Line power current imbalance greater than 3%	Problem with line power (see <i>Alarm 4 Mains phase loss</i> description).	Rotate input power leads into the 1 position: A to B, B to C, C to A.	If imbalanced leg follows the wire, it is a power problem. Check the line power supply.
	Problem with the adjustable frequency drive.	Rotate input power leads into the adjustable frequency drive one position: A to B, B to C, C to A.	If the imbalanced leg stays on same input terminal, it is a problem with the adjustable frequency drive. Contact supplier.
Motor current imbalance greater than 3%	Problem with motor or motor wiring.	Rotate output motor leads one position: U to V, V to W, W to U.	If the imbalanced leg follows the wire, the problem is in the motor or motor wiring. Check motor and motor wiring.
	Problem with adjustable frequency drive.	Rotate output motor leads one position: U to V, V to W, W to U.	If the imbalanced leg stays on same output terminal, it is a problem with the unit. Contact supplier.
Adjustable frequency drive acceleration problems	Motor data are entered incorrectly.	If warnings or alarms occur, see <i>chapter 7.5 List of Warnings and Alarms</i> . Check that motor data are entered correctly.	Increase the ramp-up time in <i>parameter 3-41 Ramp 1 Ramp-up Time</i> . Increase current limit in <i>parameter 4-18 Current Limit</i> . Increase torque limit in <i>parameter 4-16 Torque Limit Motor Mode</i> .
Adjustable frequency drive deceleration problems	Motor data are entered incorrectly.	If warnings or alarms occur, see <i>chapter 7.5 List of Warnings and Alarms</i> . Check that motor data are entered correctly.	Increase the ramp-down time in <i>parameter 3-42 Ramp 1 Ramp-down Time</i> . Enable overvoltage control in <i>parameter 2-17 Over-voltage Control</i> .

Table 7.5 Troubleshooting

8 Specifications

8.1 Electrical Data

8.1.1 Line Power Supply 3x380–500 V AC

Type designation	N90K		N110		N132		N160		N200		N250	
High/normal load*	HO	NO	HO	NO	HO	NO	HO	NO	HO	NO	HO	NO
Typical shaft output at 400 V [kW]	90	110	110	132	132	160	160	200	200	250	250	315
Typical shaft output at 460 V [Hp]	125	150	150	200	200	250	250	300	300	350	350	450
Typical shaft output at 500 V [kW]	110	132	132	160	160	200	200	250	250	315	315	355
Enclosure protection rating IP21	D1h		D1h		D1h		D2h		D2h		D2h	
Enclosure protection rating IP54	D1h		D1h		D1h		D2h		D2h		D2h	
Enclosure protection rating IP20	D3h		D3h		D3h		D4h		D4h		D4h	
Output current												
Continuous (at 400 V) [A]	177	212	212	260	260	315	315	395	395	480	480	588
Intermittent (60 s overload) (at 400 V) [A]	266	233	318	286	390	347	473	435	593	528	720	647
Continuous (at 460/500 V) [A]	160	190	190	240	240	302	302	361	361	443	443	535
Intermittent (60 s overload) (at 460/500 V) [kVA]	240	209	285	264	360	332	453	397	542	487	665	588
Continuous kVA (at 400 V) [kVA]	123	147	147	180	180	218	218	274	274	333	333	407
Continuous kVA (at 460 V) [kVA]	127	151	151	191	191	241	241	288	288	353	353	426
Continuous kVA (at 500 V) [kVA]	139	165	165	208	208	262	262	313	313	384	384	463
Maximum input current												
Continuous (at 400 V) [A]	171	204	204	251	251	304	304	381	381	463	463	567
Continuous (at 460/500 V) [A]	154	183	183	231	231	291	291	348	348	427	427	516
Additional specifications												
Maximum cable size: Line power, motor, brake and load share mm (AWG)	2x95 (2x3/0)						2x185 (2x350 mcm)					
Maximum external electrical fuses [A]	315		350		400		550		630		800	
Estimated power loss at 400 V [W] ¹⁾	2031	2559	2289	2954	2923	3770	3093	4116	4039	5137	5005	6674
Estimated power loss at 460 V [W] ¹⁾	1828	2261	2051	2724	2689	3628	2872	3569	3575	4566	4458	5714
Weight, enclosure protection rating IP21, IP54 kg (lbs.)	62 (135)						125 (275)					
Weight, enclosure protection rating IP20 kg (lbs.)	62 (135)						125 (275)					
Efficiency ²⁾	0.98											
Output frequency	0–590 Hz											
Heatsink overtemperature trip	110 °C (230 °F)											
Control card ambient trip	75 °C (167 °F)											
*High overload=150% current for 60 s, Normal overload=110% current for 60 s.												

Table 8.1 Line Power Supply 3x380–500 V AC

8.1.2 Line Power Supply 3x525–690 V AC

Type designation	N55K		N75K		N90K		N110		N132		N160	
High/normal load*	HO	NO	HO	NO	HO	NO	HO	NO	HO	NO	HO	NO
Typical shaft output at 550 V [kW]	45	55	55	75	75	90	90	110	110	132	132	160
Typical shaft output at 575 V [hp]	60	75	75	100	100	125	125	150	150	200	200	250
Typical shaft output at 690 V [kW]	55	75	75	90	90	110	110	132	132	160	160	200
Enclosure protection rating IP21	D1h		D1h		D1h		D1h		D1h		D2h	
Enclosure protection rating IP54	D1h		D1h		D1h		D1h		D1h		D2h	
Enclosure protection rating IP20	D3h		D3h		D3h		D3h		D3h		D4h	
Output current												
Continuous (at 550 V) [A]	76	90	90	113	113	137	137	162	162	201	201	253
Intermittent (60 s overload) (at 550 V) [A]	114	99	135	124	170	151	206	178	243	221	302	278
Continuous (at 575/690 V) [A]	73	86	86	108	108	131	131	155	155	192	192	242
Intermittent (60 s overload) (at 575/690 V) [kVA]	110	95	129	119	162	144	197	171	233	211	288	266
Continuous kVA (at 550 V) [kVA]	69	87	82	103	103	129	125	157	147	185	183	229
Continuous kVA (at 575 V) [kVA]	73	86	86	108	108	131	131	154	154	191	191	241
Continuous kVA (at 690 V) [kVA]	87	103	103	129	129	157	157	185	185	229	229	289
Maximum input current												
Continuous (at 550 V) [A]	77	89	89	110	110	130	130	158	158	198	198	245
Continuous (at 575 V) [A]	74	85	85	106	106	124	124	151	151	189	189	234
Continuous (at 690 V)	77	87	87	109	109	128	128	155	155	197	197	240
Additional specifications												
Maximum cable size: Line power, motor, brake and load share mm (AWG)	2x95 (2x3/0)										2x185 (2x350)	
Maximum external electrical fuses [A]	160		315		315		315		315		550	
Estimated power loss at 575 V [W] ¹⁾	1018	1162	1162	1428	1430	1740	1742	2101	2080	2649	2361	3074
Estimated power loss at 690 V [W] ¹⁾	1056	1203	1204	1476	1479	1796	1798	2165	2157	2738	2443	3172
Weight, enclosure protection rating IP21, IP54 kg (lbs.)	62 (135)										125 (275)	
Weight, enclosure protection rating IP20 kg (lbs.)	125 (275)											
Efficiency ²⁾	0.98											
Output frequency	0–590 Hz											
Heatsink overtemperature trip	110 °C (230 °F)											
Control card ambient trip	75 °C (167 °F)											
*High overload=150% current for 60 s, Normal overload=110% current for 60 s.												

Table 8.2 Line Power Supply 3x525–690 V AC

Type designation	N200		N250		N315	
High/normal load*	HO	NO	HO	NO	HO	NO
Typical shaft output at 550 V [kW]	160	200	200	250	250	315
Typical shaft output at 575 V [hp]	250	300	300	350	350	400
Typical shaft output at 690 V [kW]	200	250	250	315	315	400
Enclosure protection rating IP21	D2h		D2h		D2h	
Enclosure protection rating IP54	D2h		D2h		D2h	
Enclosure protection rating IP20	D4h		D4h		D4h	
Output current						
Continuous (at 550 V) [A]	253	303	303	360	360	418
Intermittent (60 s overload) (at 550 V) [A]	380	333	455	396	540	460
Continuous (at 575/690 V) [A]	242	290	290	344	344	400
Intermittent (60 s overload) (at 575/690 V) [kVA]	363	319	435	378	516	440
Continuous kVA (at 550 V) [kVA]	241	289	289	343	343	398
Continuous kVA (at 575 V) [kVA]	241	289	289	343	343	398
Continuous kVA (at 690 V) [kVA]	289	347	347	411	411	478
Maximum input current						
Continuous (at 550 V) [A]	245	299	299	355	355	408
Continuous (at 575 V) [A]	234	286	286	339	339	390
Continuous (at 690 V)	240	296	296	352	352	400
Additional specifications						
Maximum cable size: Line power, motor, brake and load share mm (AWG)	2x185 (2x350)					
Maximum external electrical fuses [A]	550					
Estimated power loss at 575 V [W] ¹⁾	3012	3723	3642	4465	4146	5028
Estimated power loss at 690 V [W] ¹⁾	3121	3848	3768	4610	4254	5150
Weight, enclosure protection rating IP21, IP54 kg (lbs.)	125 (275)					
Weight, enclosure protection rating IP20 kg (lbs.)	125 (275)					
Efficiency ²⁾	0.98					
Output frequency	0–590 Hz					
Heatsink overtemperature trip	110 °C (230 °F)					
Control card ambient trip	75 °C (167 °F)					

*High overload=150% current for 60 s, Normal overload=110% current for 60 s.

Table 8.3 Line Power Supply 3x525–690 V AC

1) Applies for dimensioning of adjustable frequency drive cooling. If the switching frequency is higher than the default setting, power loss may increase. LCP and typical control card power consumption is included. For power loss data according to EN 50598-2, refer to www.danfoss.com/vltenergyefficiency.

2) Efficiency measured at nominal current. For energy efficiency class, see chapter 8.4 Ambient Conditions. For part load losses, refer to www.danfoss.com/vltenergyefficiency.

The typical power loss is at nominal load conditions and expected to be within ±15% (tolerance relates to variety in voltage and cable conditions).

The losses are based on the default switching frequency. The losses increase significantly at higher switching frequencies.

The options cabinet adds weight to the adjustable frequency drive. The maximum weights of the D5h–D8h frames are shown in *Table 8.4*.

Enclosure size	Description	Maximum weight [kg (lbs.)]
D5h	D1h ratings+disconnect and/or brake chopper	166 (255)
D6h	D1h ratings+contactor and/or circuit breaker	129 (285)
D7h	D2h ratings+disconnect and/or brake chopper or oversized wiring cabinet	200 (440)
D8h	D2h ratings+contactor and/or circuit breaker	225 (496)

Table 8.4 D5h–D8h Weights

8.2 Line Power Supply

Line power supply (L1, L2, L3)

Supply voltage 380–500 V ±10%, 525–690 V ±10%

AC line voltage low/line voltage drop-out:

During low AC line voltage or a line drop-out, the adjustable frequency drive continues until the DC link voltage drops below the minimum stop level, which corresponds typically to 15% below the adjustable frequency drive's lowest rated supply voltage.

Power-up and full torque cannot be expected at AC line voltage lower than 10% below the adjustable frequency drive's lowest rated supply voltage.

Supply frequency 50/60 Hz ±5%

Maximum imbalance temporary between line power phases 3.0% of rated supply voltage

True power factor (λ) ≥0.9 nominal at rated load

Displacement power factor ($\cos \Phi$) near unity (>0.98)

Switching on input supply L1, L2, L3 (power-ups) maximum 1 time/2 minutes

Environment according to EN60664-1 Overvoltage category III/pollution degree 2

The unit is suitable for use on a circuit capable of delivering not more than 100,000 RMS symmetrical Amperes, 480/600 V



8.3 Motor Output and Motor Data

Motor output (U, V, W)

Output voltage 0–100% of supply voltage

Output frequency 0–590 Hz*

Switching on output Unlimited

Ramp times 0.01–3600 s

* *Dependent on voltage and power*

Torque characteristics

Starting torque (constant torque) maximum 160% for 60 s *

Starting torque maximum 180% up to 0.5 s*

Overload torque (constant torque) maximum 160% for 60 s*

Percentage relates to the adjustable frequency drive's nominal torque

8.4 Ambient Conditions

Environment

Enclosure size D1h/D2h/D5h/D6h/D7h/D8h IP21/Type 1, IP54/Type12

Enclosure type D3h/D4h IP20/Chassis

Vibration test all enclosure types 1.0 g

Relative humidity 5%–95% (IEC 721-3-3; Class 3K3 (non-condensing) during operation

Aggressive environment (IEC 60068-2-43) H₂S test class Kd

Test method according to IEC 60068-2-43 H₂S (10 days)

Ambient temperature (at SFAVM switching mode)

- with derating maximum 55 °C (131 °F)

- with full output power of typical EFF2 motors (up to 90% output current)	maximum 50 °C (122 °F)
- at full continuous FC output current	maximum 45 °C (113 °F)
Minimum ambient temperature during full-scale operation	0 °C (32 °F)
Minimum ambient temperature at reduced performance	10 °C (-14 °F)
Temperature during storage/transport	-25 to +65/70 °C (1-13 to + 149/158 °F)
Maximum altitude above sea level without derating	1000 m (3,300 ft)
Maximum altitude above sea level with derating	3000 m (10,000 ft)

1) For more information on derating, see the section on special conditions in the Design Guide.

EMC standards, Emission	EN 61800-3
EMC standards, Immunity	EN 61800-3
Energy efficiency class ²⁾	IE2

2) Determined according to EN50598-2 at:

- Rated load.
- 90% rated frequency.
- Switching frequency factory setting.
- Switching pattern factory setting.

8.5 Cable Specifications

Cable lengths and cross-sections for control cables¹⁾

Maximum motor cable length, shielded/armored	150 m (500 ft)
Maximum motor cable length, non-shielded/unarmored	300 m (1,000 ft)
Maximum cross-section to motor, line power, load sharing, and brake	
Maximum cross-section to control terminals, rigid wire	1.5 mm ² /16 AWG (2x0.75 mm ²)
Maximum cross-section to control terminals, flexible cable	1 mm ² /18 AWG
Maximum cross-section to control terminals, cable with enclosed core	0.5 mm ² /20 AWG
Minimum cross-section to control terminals	0.25 mm ²

1) For power cables, see electrical tables in chapter 8.1 Electrical Data.

8.6 Control Input/Output and Control Data

Digital inputs

Programmable digital inputs	4 (6)
Terminal number	18, 19, 27 ¹⁾ , 29 ¹⁾ , 32, 33
Logic	PNP or NPN
Voltage level	0–24 V DC
Voltage level, logic 0 PNP	<5 V DC
Voltage level, logic 1 PNP	>10 V DC
Voltage level, logic 0 NPN	>19 V DC
Voltage level, logic 1 NPN	<14 V DC
Maximum voltage on input	28 V DC
Input resistance, R _i	approximately 4 kΩ

All digital inputs are galvanically isolated from the supply voltage (PELV) and other high-voltage terminals.

1) Terminals 27 and 29 can also be programmed as outputs.

Analog inputs

Number of analog inputs	2
Terminal number	53, 54
Modes	Voltage or current
Mode select	Switches A53 and A54

Voltage mode	Switch A53/A54=(U)
Voltage level	-10 V to +10 V (scaleable)
Input resistance, R_i	approximately 10 k Ω
Maximum voltage	± 20 V
Current mode	Switch A53/A54=(I)
Current level	0/4 to 20 mA (scaleable)
Input resistance, R_i	approximately 200 Ω
Maximum current	30 mA
Resolution for analog inputs	10 bit (+ sign)
Accuracy of analog inputs	Maximum error 0.5% of full scale
Bandwidth	100 Hz

The analog inputs are galvanically isolated from the supply voltage (PELV) and other high-voltage terminals.

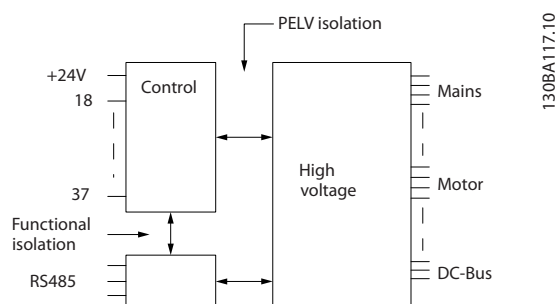

Figure 8.1 PELV Isolation

Pulse inputs	
Programmable pulse inputs	2
Terminal number pulse	29, 33
Maximum frequency at terminal, 29, 33	110 kHz (push-pull driven)
Maximum frequency at terminal, 29, 33	5 kHz (open collector)
Minimum frequency at terminal 29, 33	4 Hz
Voltage level	see chapter 8.6.1 Digital Inputs
Maximum voltage on input	28 V DC
Input resistance, R_i	approximately 4 k Ω
Pulse input accuracy (0.1–1 kHz)	Maximum error: 0.1% of full scale

Analog output	
Number of programmable analog outputs	1
Terminal number	42
Current range at analog output	0/4–20 mA
Maximum resistor load to common at analog output	500 Ω
Accuracy on analog output	Maximum error: 0.8% of full scale
Resolution on analog output	8 bit

The analog output is galvanically isolated from the supply voltage (PELV) and other high-voltage terminals.

Control card, RS485 serial communication	
Terminal number	68 (P,TX+, RX+), 69 (N,TX-, RX-)
Terminal number 61	Common for terminals 68 and 69

The RS485 serial communication circuit is functionally separated from other central circuits and galvanically isolated from the supply voltage (PELV).

Digital output

Programmable digital/pulse outputs	2
Terminal number	27, 29 ¹⁾
Voltage level at digital/frequency output	0–24 V
Maximum output current (sink or source)	40 mA
Maximum load at frequency output	1 kΩ
Maximum capacitive load at frequency output	10 nF
Minimum output frequency at frequency output	0 Hz
Maximum output frequency at frequency output	32 kHz
Accuracy of frequency output	Maximum error: 0.1% of full scale
Resolution of frequency outputs	12 bit

1) Terminals 27 and 29 can also be programmed as inputs.

The digital output is galvanically isolated from the supply voltage (PELV) and other high-voltage terminals.

Control card, 24 V DC output

Terminal number	12, 13
Maximum load	200 mA

The 24 V DC supply is galvanically isolated from the supply voltage (PELV), but has the same potential as the analog and digital inputs and outputs.

8
Relay outputs

Programmable relay outputs	2
Relay 01 Terminal number	1–3 (break), 1–2 (make)
Maximum terminal load (AC-1) ¹⁾ on 1–2 (NO) (Resistive load) ²⁾³⁾	400 V AC, 2 A
Maximum terminal load (AC-15) ¹⁾ on 1–2 (NO) (Inductive load @ cosφ 0.4)	240 V AC, 0.2 A
Maximum terminal load (DC-1) ¹⁾ on 1–2 (NO) (Resistive load)	80 V DC, 2 A
Maximum terminal load (DC-13) ¹⁾ on 1–2 (NO) (Inductive load)	24 V DC, 0.1 A
Maximum terminal load (AC-1) ¹⁾ on 1–3 (NC) (Resistive load)	240 V AC, 2 A
Maximum terminal load (AC-15) ¹⁾ on 1–3 (NC) (Inductive load @ cosφ 0.4)	240 V AC, 0.2 A
Maximum terminal load (DC-1) ¹⁾ on 1–3 (NC) (Resistive load)	50 V DC, 2 A
Maximum terminal load (DC-13) ¹⁾ on 1–3 (NC) (Inductive load)	24 V DC, 0.1 A
Minimum terminal load on 1–3 (NC), 1–2 (NO)	24 V DC 10 mA, 24 V AC 2 mA
Environment according to EN 60664-1	Overvoltage category III/pollution degree 2
Relay 02 Terminal number	4–6 (break), 4–5 (make)
Maximum terminal load (AC-1) ¹⁾ on 4–5 (NO) (Resistive load) ²⁾³⁾	400 V AC, 2 A
Maximum terminal load (AC-15) ¹⁾ on 4–5 (NO) (Inductive load @ cosφ 0.4)	240 V AC, 0.2 A
Maximum terminal load (DC-1) ¹⁾ on 4–5 (NO) (Resistive load)	80 V DC, 2 A
Maximum terminal load (DC-13) ¹⁾ on 4–5 (NO) (Inductive load)	24 V DC, 0.1 A
Maximum terminal load (AC-1) ¹⁾ on 4–6 (NC) (Resistive load)	240 V AC, 2 A
Maximum terminal load (AC-15) ¹⁾ on 4–6 (NC) (Inductive load @ cosφ 0.4)	240 V AC, 0.2 A
Maximum terminal load (DC-1) ¹⁾ on 4–6 (NC) (Resistive load)	50 V DC, 2 A
Maximum terminal load (DC-13) ¹⁾ on 4–6 (NC) (Inductive load)	24 V DC, 0.1 A
Minimum terminal load on 4–6 (NC), 4–5 (NO)	24 V DC 10 mA, 24 V AC 2 mA
Environment according to EN 60664-1	Overvoltage category III/pollution degree 2

1) IEC 60947 part 4 and 5

The relay contacts are galvanically isolated from the rest of the circuit by reinforced isolation (PELV).

2) Overvoltage Category II

3) UL applications 300 V AC 2 A

Terminal number	50
Output voltage	10.5 V \pm 0.5 V
Maximum load	25 mA

The 10 V DC supply is galvanically isolated from the supply voltage (PELV) and other high-voltage terminals.

Control characteristics

Resolution of output frequency at 0–1000 Hz	\pm 0.003 Hz
System response time (terminals 18, 19, 27, 29, 32, 33)	\leq 2 ms
Speed control range (open-loop)	1:100 of synchronous speed
Speed accuracy (open-loop)	30–4000 RPM: Maximum error of \pm 8 RPM

All control characteristics are based on a 4-pole asynchronous motor

Control card performance

Scan interval	5 ms
---------------	------

Control card, USB serial communication

USB standard	1.1 (full speed)
USB plug	USB type B device plug

CAUTION

Connection to PC is carried out via a standard host/device USB cable.

The USB connection is galvanically isolated from the supply voltage (PELV) and other high-voltage terminals.

The USB connection is not galvanically isolated from protection ground. Use only an isolated laptop/PC as the connection to the USB connector on the adjustable frequency drive or an isolated USB cable/drive.

8.7 Fuses

8.7.1 Fuse Selection

Use recommended fuses and/or circuit breakers on the supply side as protection in case of component breakdown inside the adjustable frequency drive (first fault).

NOTICE!

Use of fuses on the supply side is mandatory for IEC 60364 (CE) and NEC 2009 (UL) compliant installations.

Use the recommended fuses to ensure compliance with EN50178. Use of recommended fuses and circuit breakers ensures that possible damage to the adjustable frequency drive is limited to damages inside the unit. For further information, see *Application Note Fuses and Circuit Breakers*.

The fuses below are suitable for use on a circuit capable of delivering 100000 A_{rms} (symmetrical), depending on the adjustable frequency drive voltage rating. With the proper fusing, the adjustable frequency drive short-circuit current rating (SCCR) is 100000 A_{rms}.

N90K-N250	380–500 V	type aR
N55K-N315	525–690 V	type aR

Table 8.5 Recommended Fuses

Power size	Bussman PN	Littelfuse PN	Littelfuse PN	Bussmann PN	Siba PN	Ferraz-Shawmut PN	Ferraz-Shawmut PN (Europe)	Ferraz-Shawmut PN (North America)
N90K	170M2619	LA50QS300-4	L50S-300	FWH-300A	20 610 31.315	A50QS300-4	6.9URD31D08A0315	A070URD31KI0315
N110	170M2620	LA50QS350-4	L50S-350	FWH-350A	20 610 31.350	A50QS350-4	6.9URD31D08A0350	A070URD31KI0350
N132	170M2621	LA50QS400-4	L50S-400	FWH-400A	20 610 31.400	A50QS400-4	6.9URD31D08A0400	A070URD31KI0400
N160	170M4015	LA50QS500-4	L50S-500	FWH-500A	20 610 31.550	A50QS500-4	6.9URD31D08A0550	A070URD31KI0550
N200	170M4016	LA50QS600-4	L50S-600	FWH-600A	20 610 31.630	A50QS600-4	6.9URD31D08A0630	A070URD31KI0630
N250	170M4017	LA50QS800-4	L50S-800	FWH-800A	20 610 31.800	A50QS800-4	6.9URD32D08A0800	A070URD31KI0800

Table 8.6 Fuse Options for 380–500 V Adjustable Frequency Drives

Power size	Bussmann PN	Siba PN	Ferraz-Shawmut European PN	Ferraz-Shawmut North American PN
N55k T7	170M2616	20 610 31.160	6.9URD30D08A0160	A070URD30KI0160
N75k T7	170M2619	20 610 31.315	6.9URD31D08A0315	A070URD31KI0315
N90k T7	170M2619	20 610 31.315	6.9URD31D08A0315	A070URD31KI0315
N110 T7	170M2619	20 610 31.315	6.9URD31D08A0315	A070URD31KI0315
N132 T7	170M2619	20 610 31.315	6.9URD31D08A0315	A070URD31KI0315
N160 T7	170M4015	20 620 31.550	6.9URD32D08A0550	A070URD32KI0550
N200 T7	170M4015	20 620 31.550	6.9URD32D08A0550	A070URD32KI0550
N250 T7	170M4015	20 620 31.550	6.9URD32D08A0550	A070URD32KI0550
N315 T7	170M4015	20 620 31.550	6.9URD32D08A0550	A070URD32KI0550

Table 8.7 Fuse Options for 525–690 V Adjustable Frequency drives

For UL compliance, use the Bussmann 170M series fuses for units supplied without a contactor-only option. See *Table 8.9* for SCCR ratings and UL fuse criteria if a contactor-only option is supplied with the adjustable frequency drive.

8.7.2 Short Circuit Current Rating (SCCR)

If the adjustable frequency drive is not supplied with a line power disconnect, contactor or circuit breaker, the Short Circuit Current Rating (SCCR) of the adjustable frequency drives is 100000 amps at all voltages (380–690 V).

If the adjustable frequency drive is supplied with a line power disconnect, the SCCR of the adjustable frequency drive is 100,000 amps at all voltages (380–690 V).

If the adjustable frequency drive is supplied with a circuit breaker, the SCCR depends on the voltage, see *Table 8.8*:

	415 V	480 V	600 V	690 V
D6h frame	120000 A	100000 A	65000 A	70000 A
D8h frame	100000 A	100000 A	42000 A	30000 A

Table 8.8 Adjustable Frequency Drive Supplied with a Circuit Breaker

If the adjustable frequency drive is supplied with a contactor-only option and is externally fused according to *Table 8.9*, the SCCR of the adjustable frequency drive is as follows:

	415 V IEC ¹⁾	480 V UL ²⁾	600 V UL ²⁾	690 V IEC ¹⁾
D6h frame	100000 A	100000 A	100000 A	100000 A
D8h frame (not including the N250T5)	100000 A	100000 A	100000 A	100000 A
D8h frame (N250T5 only)	100000 A	Consult factory	Not applicable	

Table 8.9 Adjustable Frequency Drive Supplied with a Contactor

- 1) With a Bussmann type LPJ-SP or Gould Shawmut type AJT fuse. 450 A max fuse size for D6h and 900 A max fuse size for D8h.
- 2) Must use Class J or L branch fuses for UL approval. 450 A max fuse size for D6h and 600 A max fuse size for D8h.

8.8 Connection Tightening Torques

Tighten with the correct torque when tightening all electrical connections. Too low or too high torque results in a bad electrical connection. To ensure correct torque, use a torque wrench.

Enclosure size	Terminal	Torque [Nm (in-lbs)]	Bolt size
D1h/D3h/D5h/D6h	Line power Motor Load sharing Regen	19–40 (168–354)	M10
	Ground Brake	8.5–20.5 (75–181)	M8
	Heatsink access panel	2.27 (20)	
D2h/D4h/D7h/D8h	Line power Motor Regen Load sharing Ground	19–40 (168–354)	M10
	Brake	8.5–20.5 (75–181)	M8
	Heatsink access panel	2.27 (20)	

Table 8.10 Torque for Terminals

8.9 Power Ratings, Weight and Dimensions

Enclosure size		D1h	D2h	D3h	D4h	D3h	D4h
Rated power [kW]		90–132 kW (380–500 V) 90–132 kW (525–690 V)	160–250 kW (380–500 V) 160–315 kW (525–690 V)	90–132 kW (380–500 V) 37–132 kW (525–690 V)	160–250 kW (380–500 V) 160–315 kW (525–690 V)	With regeneration or load share terminals	
IP NEMA		21/54 Type 1/12	21/54 Type 1/12	20 Chassis	20 Chassis	20 Chassis	20 Chassis
Shipping dimensions [mm (inch)]	Height	587 (23)	587 (23)	587 (23)	587 (23)	587 (23)	587 (23)
	Width	997 (39)	1170 (46)	997 (39)	1170 (46)	1230 (48)	1430 (56)
	Depth	460 (18)	535 (21)	460 (18)	535 (21)	460 (18)	535 (21)
Adjustable frequency drive dimensions [mm (inch)]	Height	893 (35)	1099 (43)	909 (36)	1122 (44)	1004 (40)	1268 (50)
	Width	325 (13)	420 (17)	250 (10)	350 (14)	250 (10)	350 (14)
	Depth	378 (15)	378 (15)	375 (15)	375 (15)	375 (15)	375 (15)
Maximum weight [kg (lb)]		98 (216)	164 (362)	98 (216)	164 (362)	108 (238)	179 (395)

Table 8.11 Power Ratings, Weight, and Dimensions, Enclosure Size D1h-D4h

Enclosure size		D5h	D6h	D7h	D8h
Rated power [kW]					
IP		21/54	21/54	21/54	21/54
NEMA		Type 1/12	Type 1/12	Type 1/12	Type 1/12
Shipping dimensions [mm (inch)]	Height	1805 (71)	1805 (71)	2490 (98)	2490 (98)
	Width	510 (20)	510 (20)	585 (23)	585 (23)
	Depth	635 (25)	635 (25)	640 (25)	640 (25)
Adjustable frequency drive dimensions [mm (inch)]	Height	1324 (52)	1665 (66)	1978 (78)	2284 (90)
	Width	325 (13)	325 (13)	420 (17)	420 (17)
	Depth	381 (15)	381 (15)	386 (15)	406 (16)
Maximum weight [kg (lb)]		449 (990)	449 (990)	530 (1168)	530 (1168)

Table 8.12 Power Ratings, Weight, and Dimensions, Enclosure Size D5h-D8h

9 Appendix

9.1 Symbols, Abbreviations, and Conventions

°C	Degrees celsius
AC	Alternating current
AEO	Automatic energy optimization
AWG	American wire gauge
AMA	Automatic motor adaptation
DC	Direct current
EMC	Electro magnetic compatibility
ETR	Electronic thermal relay
$f_{M,N}$	Nominal motor frequency
FC	Adjustable frequency drive
I_{INV}	Rated inverter output current
I_{LIM}	Current limit
$I_{M,N}$	Nominal motor current
$I_{VLT,MAX}$	Maximum output current
$I_{VLT,N}$	Rated output current supplied by the adjustable frequency drive
IP	Ingress protection
LCP	Local control panel
MCT	Motion control tool
n_s	Synchronous motor speed
$P_{M,N}$	Nominal motor power
PELV	Protective extra low voltage
PCB	Printed circuit board
PM Motor	Permanent magnet motor
PWM	Pulse width modulated
RPM	Revolutions per minute
Regen	Regenerative terminals
T_{LIM}	Torque limit
$U_{M,N}$	Nominal motor voltage

Table 9.1 Symbols and Abbreviations

Conventions

Numbered lists indicate procedures.

Bullet lists indicate other information.

Italicized text indicates:

- Cross reference
- Link
- Parameter name

All dimensions are in (in [mm]).

9.2 Parameter Menu Structure

Code	Operation/Display	Motor Model	Start Speed [RPM]	Reference Limits	Ramp Time
0-0*	Basic Settings	Damping Gain	1-74	3-0*	3-91
0-01	Language	Low Speed Filter Time Const.	1-75	3-00	3-92
0-02	Motor Speed Unit	High Speed Filter Time Const.	1-76	3-01	3-93
0-03	Regional Settings	Voltage Filter Time Const.	1-8*	3-02	3-94
0-04	Operating State at Power-up (Hand)	Min. Current at No Load	1-80	3-03	3-95
0-09	Performance Monitor	Motor Data	1-81	3-04	4-*
0-1*	Set-up Operations	Motor Power [kW]	1-82	3-1*	4-1*
0-10	Active Set-up	Motor Power [HP]	1-83	3-10	4-10
0-11	Edit Set-up	Motor Voltage	1-84	3-11	4-11
0-12	This Set-up Linked to	Motor Frequency	1-85	3-12	4-12
0-13	Readout: Linked Set-ups	Motor Current	1-9*	3-13	4-13
0-14	Readout: Edit Set-ups / Channel	Motor Nominal Speed	1-90	3-14	4-14
0-15	Readout: Actual set-up	Motor Cont. Rated Torque	1-91	3-15	4-16
0-2*	LCP Display	Automatic Motor Adaptation (AMA)	1-92	3-16	4-17
0-20	Display Line 1.1 Small	Adv. Motor Data	1-93	3-17	4-18
0-21	Display Line 1.2 Small	Stator Resistance (Rs)	1-94	3-18	4-19
0-22	Display Line 1.3 Small	Rotor Resistance (Rr)	1-95	3-19	4-20
0-23	Display Line 2 Large	Rotor Leakage Reactance (Xl)	1-96	3-4*	4-20
0-24	Display Line 3 Large	Rotor Leakage Reactance (X2)	1-97	3-40	4-21
0-25	My Personal Menu	Main Reactance (Xh)	1-98	3-41	4-23
0-3*	LCP Custom Readout	Iron Loss Resistance (Rfe)	1-99	3-42	4-24
0-30	Unit for User-defined Readout	d-axis Inductance (Ld)	2-*	3-43	4-3*
0-31	Min Value of User-defined Readout	q-axis Inductance (Lq)	2-0*	3-44	4-30
0-32	Max Value of User-defined Readout	Motor Poles	2-00	3-45	4-31
0-37	Display Text 1	Back EMF at 1,000 RPM	2-01	3-46	4-32
0-38	Display Text 2	Motor Angle Offset	2-02	3-47	4-34
0-39	Display Text 3	d-axis Inductance Sat. (LdSat)	2-03	3-50	4-35
0-4*	LCP Keypad	q-axis Inductance Sat. (LqSat)	2-04	3-51	4-36
0-40	[Hand on] Key on LCP	Position Detection Gain	2-05	3-52	4-37
0-41	[Off] Key on LCP	Torque Calibration	2-06	3-53	4-38
0-42	[Auto on] Key on LCP	Inductance Sat. Point	2-07	3-54	4-39
0-43	[Reset] Key on LCP	Load Indep. Setting	2-1*	3-55	4-39
0-44	[Off/Reset] Key on LCP	Motor Magnetization at Zero Speed	2-10	3-56	4-5*
0-45	[Drive Bypass] Key on LCP	Min Speed Normal Magnetizing [RPM]	2-11	3-57	4-50
0-5*	Copy/Save	Model Shift Frequency	2-12	3-60	4-51
0-50	LCP Copy	Min Speed Normal Magnetizing [Hz]	2-13	3-61	4-52
0-51	Set-up Copy	Model Shift Frequency	2-15	3-62	4-53
0-6*	Password	Voltage reduction in field weakening	2-16	3-65	4-54
0-60	Main Menu Password	U/f Characteristic - U	2-17	3-66	4-55
0-61	Access to Main Menu w/o Password	U/f Characteristic - F	2-18	3-67	4-56
0-65	Quick Menu Password	Flying Start Test Pulses Current	2-19	3-68	4-57
0-66	Access to Quick Menu w/o Password	Flying Start Test Pulses Frequency	2-2*	3-70	4-58
0-67	Bus Password Access	Load Depen. Setting	2-20	3-71	4-6*
0-68	Safety Parameters Password	Low Speed Load Compensation	2-21	3-72	4-60
0-69	Password Protection of Safety Parameters	High Speed Load Compensation	2-22	3-73	4-61
1-*	Load and Motor	Slip Compensation Time Constant	2-23	3-76	4-63
1-0*	General Settings	Slip Compensation Time Constant	2-24	3-77	5-*
1-00	Configuration Mode	Resonance Damping	2-25	3-78	5-0*
1-01	Motor Control Principle	Resonance Damping Time Constant	2-26	3-8*	5-00
1-02	Flux Motor Feedback Source	Min. Current at Low Speed	2-27	3-80	5-01
1-03	Torque Characteristics	Load Type	2-28	3-81	5-02
1-04	Overload Mode	Motor Inertia	2-29	3-82	5-1*
1-05	Local Mode Configuration	System Inertia	2-30	3-83	5-10
1-06	Clockwise Direction	Start Adjustments	2-31	3-84	5-11
1-07	Motor Angle Offset Adjust	PM Start Mode	2-32	3-84	5-12
1-1*	Special Settings	Start Delay	2-33	3-9*	5-13
1-10	Motor Construction	Flying Start	3-*	3-90	5-14
					5-15

5-16	Terminal X30/2 Digital Input	Terminal 53 High Current	7-05	Speed PID Diff. Gain Limit	8-19	Product Code	9-70	Edit Set-up
5-17	Terminal X30/3 Digital Input	Terminal 53 Low Ref./Feedb. Value	7-06	Speed PID Low-pass Filter Time	8-3*	FC Port Settings	9-71	Profibus Save Data Values
5-18	Terminal X30/4 Digital Input	Terminal 53 High Ref./Feedb. Value	7-07	Speed PID Feedback Gear Ratio	8-30	Protocol	9-72	ProfibusDrivesReset
5-19	Terminal 37 Safe Stop	Terminal 53 Filter Time Constant	7-08	Speed PID Feed Forward Factor	8-31	Address	9-75	DO Identification
5-20	Terminal X46/1 Digital Input	Analog Input 2	7-09	Speed PID Error Correction w/ Ramp	8-32	FC Port Baud Rate	9-80	Defined Parameters (1)
5-21	Terminal X46/3 Digital Input	Terminal 54 Low Voltage	7-1*	Torque PI Ctrl.	8-33	Parity / Stop Bits	9-81	Defined Parameters (2)
5-22	Terminal X46/5 Digital Input	Terminal 54 High Voltage	7-10	Torque PI Feedback Source	8-34	Estimated cycle time	9-82	Defined Parameters (3)
5-23	Terminal X46/7 Digital Input	Terminal 54 Low Current	7-12	Torque PI Proportional Gain	8-35	Minimum Response Delay	9-83	Defined Parameters (4)
5-24	Terminal X46/9 Digital Input	Terminal 54 High Current	7-13	Torque PI Integration Time	8-36	Max Response Delay	9-84	Defined Parameters (5)
5-25	Terminal X46/11 Digital Input	Terminal 54 Low Ref./Feedb. Value	7-16	Torque PI Low-pass Filter Time	8-37	Max Inter-Char Delay	9-85	Defined Parameters (6)
5-26	Terminal X46/13 Digital Input	Terminal 54 High Ref./Feedb. Value	7-18	Torque PI Forward Factor	8-4*	FC MC protocol set	9-90	Changed Parameters (1)
5-3*	Digital Outputs	Terminal 54 Filter Time Constant	7-19	Current Controller Rise Time	8-40	Message Selection	9-91	Changed Parameters (2)
5-30	Terminal 27 Digital Output	Analog Input 3	7-2*	Process Ctrl. Feedb	8-41	Parameters for Signals	9-92	Changed Parameters (3)
5-31	Terminal 29 Digital Output	Terminal X30/11 Low Voltage	7-20	Process CL Feedback 1 Resource	8-42	PCD Write Configuration	9-93	Changed Parameters (4)
5-32	Term X30/6 Digi Out (MCB 101)	Terminal X30/11 High Voltage	7-22	Process CL Feedback 2 Resource	8-43	PCD Read Configuration	9-94	Changed Parameters (5)
5-33	Term X30/7 Digi Out (MCB 101)	Term. X30/11 Low Ref./Feedb. Value	7-3*	Process PID Ctrl.	8-45	BTM Transaction Command	9-99	Profibus Revision Counter
5-4*	Relays	Term. X30/11 High Ref./Feedb. Value	7-30	Process PID Normal/ Inverse Control	8-46	BTM Transaction Status	10-3*	CAN Fieldbus
5-40	Function Relay	Term. X30/11 Filter Time Constant	7-31	Process PID Anti Windup	8-47	BTM Timeout	10-0*	Common Settings
5-41	On Delay Relay	Analog Input 4	7-32	Process PID Start Speed	8-48	BTM Maximum Errors	10-00	CAN Protocol
5-42	Off Delay Relay	Terminal X30/12 Low Voltage	7-33	Process PID Proportional Gain	8-49	BTM Error Log	10-01	Baud Rate Select
5-5*	Pulse Input	Terminal X30/12 High Voltage	7-34	Process PID Integral Time	8-5*	Digital/Bus	10-02	MAC ID
5-50	Term. 29 Low Frequency	Term. X30/12 Low Ref./Feedb. Value	7-35	Process PID Differentiation Time	8-50	Coasting Select	10-05	Readout Transmit Error Counter
5-51	Term. 29 High Frequency	Term. X30/12 High Ref./Feedb. Value	7-36	Process PID Diff. Gain Limit	8-51	Quick Stop Select	10-06	Readout Receive Error Counter
5-52	Term. 29 Low Ref./Feedb. Value	Term. X30/12 Filter Time Constant	7-38	Process PID Feed Forward Factor	8-52	DC Brake Select	10-07	Readout Bus-off Counter
5-53	Term. 29 High Ref./Feedb. Value	Analog Output 1	7-39	On Reference Bandwidth	8-53	Start Select	10-1*	DeviceNet
5-54	Pulse Filter Time Constant #29	Terminal 42 Output	7-4*	Adv. Process PID I	8-54	Reversing Select	10-10	Process Data Type Selection
5-55	Term. 33 Low Frequency	Terminal 42 Output Min Scale	7-40	Process PID I-part Reset	8-55	Set-up Select	10-11	Process Data Config Write
5-56	Term. 33 High Frequency	Terminal 42 Output Max Scale	7-41	Process PID Output Neg. Clamp	8-56	Preset Reference Select	10-12	Process Data Config Read
5-57	Term. 33 Low Ref./Feedb. Value	Term 42 Output Bus Ctrl	7-42	Process PID Output Pos. Clamp	8-57	Profidrive OFF2 Select	10-13	Warning Parameter
5-58	Term. 33 High Ref./Feedb. Value	Terminal 42 Output Timeout Preset	7-43	Process PID Gain Scale at Min. Ref.	8-58	Profidrive OFF3 Select	10-14	Net Reference
5-59	Pulse Filter Time Constant #33	Analog Output Filter	7-44	Process PID Gain Scale at Max. Ref.	8-8*	FC Port Diagnostics	10-15	Net Control
5-6*	Pulse Output	Analog Output 2	7-45	Process PID Feed Fwd Resource	8-80	Bus Message Count	10-2*	COS Filters
5-60	Terminal 27 Pulse Output Variable	Terminal X30/8 Output	7-46	Process PID Feed Fwd Normal/ Inv. Ctrl.	8-81	Bus Error Count	10-20	COS Filter 1
5-62	Pulse Output Max Freq #27	Terminal X30/8 Min. Scale	7-48	PCD Feed Forward	8-82	Slave Messages Rcvd	10-21	COS Filter 2
5-63	Terminal 29 Pulse Output Variable	Terminal X30/8 Max. Scale	7-49	Process PID Output Normal/ Inv. Ctrl.	8-83	Slave Error Count	10-22	COS Filter 3
5-65	Pulse Output Max Freq #29	Terminal X30/8 Bus Control	7-5*	Adv. Process PID II	8-90	Bus Jog 1 Speed	10-23	COS Filter 4
5-66	Terminal X30/6 Pulse Output Variable	Terminal X30/8 Output Timeout	7-50	Process PID Extended PID	8-91	Bus Jog 2 Speed	10-3*	Parameter Access
5-68	Pulse Output Max Freq #X30/6	Preset	7-51	Process PID Feed Fwd Gain	9-*	PROFIDRIVE	10-30	Array Index
5-7*	24 V Encoder Input	Analog Output 3	7-52	Process PID Feed Fwd Ramp-up	9-00	Setpoint	10-31	Store Data Values
5-70	Term 32/33 Pulses Per Revolution	Terminal X45/1 Output	7-53	Process PID Feed Fwd Ramp-down	9-07	Actual Value	10-32	Devicenet Revision
5-71	Term 32/33 Encoder Direction	Terminal X45/1 Min. Scale	7-56	Process PID Ref. Filter Time	9-15	PCD Write Configuration	10-33	Store Always
5-8*	I/O Options	Terminal X45/1 Max. Scale	7-57	Process PID Fb. Filter Time	9-16	PCD Read Configuration	10-34	DeviceNet Product Code
5-80	AHF Cap Reconnect Delay	Terminal X45/1 Bus Control	8-*	Comm. and Options	9-18	Node Address	10-39	Devicenet F Parameters
5-9*	Bus Controlled	Terminal X45/1 Output Timeout	8-0*	General Settings	9-19	Drive Unit System Number	10-5*	CANopen
5-90	Digital & Relay Bus Control	Preset	8-01	Control Site	9-22	Message Selection	10-50	Process Data Config Write.
5-93	Pulse Out #27 Bus Control	Analog Output 4	8-02	Control Word Source	9-23	Parameters for Signals	10-51	Process Data Config Read.
5-94	Pulse Out #27 Timeout Preset	Terminal X45/3 Output	8-03	Control Word Timeout Time	9-27	Parameter Edit	12-*	Ethernet
5-95	Pulse Out #29 Bus Control	Terminal X45/3 Min. Scale	8-04	Control Word Timeout Function	9-28	Process Control	12-0*	IP Settings
5-96	Pulse Out #29 Timeout Preset	Terminal X45/3 Max. Scale	8-05	End-of-Timeout Function	9-44	Fault Message Counter	12-00	IP Address Assignment
5-97	Pulse Out #X30/6 Bus Control	Terminal X45/3 Bus Control	8-06	Diagnosis Trigger	9-45	Fault Code	12-01	IP Address
5-98	Pulse Out #X30/6 Timeout Preset	Terminal X45/3 Output Timeout	8-07	Readout Filtering	9-52	Fault Situation Counter	12-02	Subnet Mask
6-*	Analog In/Out	Controllers	8-08	Speed PID Ctrl.	9-53	Profibus Warning Word	12-03	Default Gateway
6-0*	Analog I/O Mode	7-*	8-10	Control Word Profile	9-63	Actual Baud Rate	12-04	DHCP Server
6-00	Live Zero Timeout Time	Speed PID Feedback Source	7-00	Speed PID Droop	9-64	Device Identification	12-05	Lease Expires
6-01	Live Zero Timeout Function	Speed PID Droop	7-01	Speed PID Proportional Gain	9-65	Profile Number	12-06	Name Servers
6-1*	Analog Input 1	Speed PID Integral Time	7-03	Speed PID Differentiation Time	9-67	Control Word 1	12-07	Domain Name
6-10	Terminal 53 Low Voltage	Speed PID Differentiation Time	7-04				12-08	Host Name
6-11	Terminal 53 High Voltage						12-09	Physical Address
6-12	Terminal 53 Low Current							



12-1*	Ethernet Link Parameters	13-02	Stop Event	15-61	Option SW Version	16-46	Motor Phase V Current
12-10	Link Status	13-03	Reset SLC	15-62	Option Ordering No	16-47	Motor Phase W Current
12-11	Link Duration	13-03*	Comparators	15-63	Option Serial No	16-48	Speed Ref. After Ramp [RPM]
12-12	Auto Negotiation	13-10	Comparator Operand	15-70	Option in Slot A	16-49	Current Fault Source
12-13	Link Speed	13-11	Comparator Operator	15-71	Slot A Option SW Version	16-5*	Ref. & Feedb.
12-14	Link Duplex	13-12	Comparator Value	15-72	Option in Slot B	16-50	External Reference
12-2*	Process Data	13-1*	RS Flip Flops	15-73	Slot B Option SW Version	16-51	Pulse Reference
12-20	Control Instance	13-15	RS-FF Operand S	15-74	Option in Slot C0/EO	16-52	Feedback[Unit]
12-21	Process Data Config Write	13-16	RS-FF Operand R	15-75	Slot C0/EO Option SW Version	16-53	Digi. Pot Reference
12-22	Process Data Config Read	13-2*	Timers	15-76	Option in Slot C1/E1	16-57	Feedback [RPM]
12-23	Process Data Config Write Size	13-20	SL Controller Timer	15-77	Slot C1/E1 Option SW Version	16-6*	Inputs & Outputs
12-24	Process Data Config Read Size	13-4*	Logic Rules	15-8*	Operating Data II	16-60	Digital Input
12-27	Master Address	13-40	Logic Rule Boolean 1	15-80	Fan Running Hours	16-61	Terminal 53 Switch Setting
12-28	Store Data Values	13-41	Logic Rule Operator 1	15-81	Preset Fan Running Hours	16-62	Analog Input 53
12-29	Store Always	13-42	Logic Rule Boolean 2	15-89	Configuration Change Counter	16-63	Terminal 54 Switch Setting
12-3*	EtherNet/IP	13-43	Logic Rule Operator 2	15-9*	Parameter Info	16-64	Analog Input 54
12-30	Warning Parameter	13-44	Logic Rule Boolean 3	15-92	Defined Parameters	16-65	Analog Output 42 [mA]
12-31	Net Reference	13-5*	States	15-93	Modified Parameters	16-66	Digital Output [bin]
12-32	Net Control	13-51	SL Controller Event	15-98	Drive Identification	16-67	Freq. Input #29 [Hz]
12-33	CIP Revision	13-52	SL Controller Action	15-99	Parameter Metadata	16-68	Freq. Input #33 [Hz]
12-34	CIP Product Code	14-*	Special Functions	16-*	Data Readouts	16-69	Pulse Output #27 [Hz]
12-35	EDS Parameter	14-0*	Inverter Switching	16-0*	General Status	16-70	Pulse Output #29 [Hz]
12-37	COS Inhibit Timer	14-00	Switching Pattern	16-00	Control Word	16-71	Relay Output [bin]
12-38	COS Filter	14-01	Switching Frequency	16-01	Reference [Unit]	16-72	Counter A
12-4*	Modbus TCP	14-03	Overmodulation	16-02	Reference %	16-73	Counter B
12-40	Status Parameter	14-04	PWM Random	16-03	Status Word	16-74	Prec. Stop Counter
12-41	Slave Message Count	14-06	Dead Time Compensation	16-05	Main Actual Value [%]	16-75	Analog in X30/11
12-42	Slave Exception Message Count	14-1*	Mains On/Off	16-06	Absolute Position	16-76	Analog in X30/12
12-5*	EtherCAT	14-10	Line failure	16-09	Custom Readout	16-77	Analog Out X45/1 [mA]
12-50	Configured Station Alias	14-11	Mains Voltage at Mains Fault	16-1*	Motor Status	16-78	Analog Out X45/1 [mA]
12-51	Configured Station Address	14-12	Function at Mains Imbalance	16-10	Power [hp [kW]]	16-8*	Fieldbus & FC Port
12-59	EtherCAT Status	14-14	Kin. Backup Timeout	16-11	Power [hp]	16-80	Serial communication bus CTW 1
12-6*	Ethernet PowerLink	14-15	Kin. Backup Trip Recovery Level	16-12	Motor Voltage	16-82	Serial communication bus REF 1
12-60	Node ID	14-16	Kin. Backup Gain	16-13	Frequency	16-84	Comm. Option STW
12-62	SDO Timeout	14-2*	Trip Reset	16-14	Motor current	16-85	FC Port CTW 1
12-63	Basic Ethernet Timeout	14-20	Reset Mode	16-15	Frequency [%]	16-86	FC Port REF 1
12-66	Threshold	14-21	Automatic Restart Time	16-16	Torque [Nm]	16-87	Bus Readout Alarm/Warning
12-67	Threshold Counters	14-22	Operation Mode	16-17	Speed [RPM]	16-89	Configurable Alarm/Warning Word
12-68	Cumulative Counters	14-23	Typecode Setting	16-18	Motor Thermal	16-90	Alarm Word
12-69	Ethernet PowerLink Status	14-24	Trip Delay at Current Limit	16-19	KTY sensor temperature	16-91	Alarm Word 2
12-8*	Other Ethernet Services	14-25	Trip Delay at Torque Limit	16-20	Motor Angle	16-92	Warning Word
12-80	FIP Server	14-26	Trip Delay at Inverter Fault	16-21	Torque [%] High Res.	16-93	Warning Word 2
12-81	HTTP Server	14-28	Production Settings	16-22	Torque [%]	16-94	Ext. Status Word
12-82	SMTP Service	14-29	Service Code	16-24	Calibrated Stator Resistance	17-*	Feedback
12-89	Transparent Socket Channel Port	14-3*	Current Limit Ctrl.	16-25	Torque [Nm] High	17-1*	Inc. Enc. Interface
12-9*	Advanced Ethernet Services	14-30	Current Lim Ctrl, Proportional Gain	16-30	DC Link Voltage	17-10	Signal Type
12-90	Cable Diagnostic	14-31	Current Lim Ctrl, Integration Time	16-32	Brake Energy /s	17-11	Resolution (PPR)
12-91	Auto Cross Over	14-32	Current Lim Ctrl, Filter Time	16-33	Brake Energy Average	17-2*	Abs. Enc. Interface
12-92	IGMP Snooping	14-35	Stall Protection	16-34	Heatsink Temp.	17-20	Protocol Selection
12-93	Cable Error Length	14-36	Field Weakening Function	16-35	Inverter Thermal	17-21	Resolution (Positions/Rev)
12-94	Broadcast Storm Protection	14-40	Energy Optimizing	16-36	Inv. Nom. Current	17-24	SSI Data Length
12-95	Broadcast Storm Filter	14-40	VT Level	16-37	Inv. Max. Current	17-25	Clock Rate
12-96	Port Config	14-41	AEO Minimum Magnetization	16-38	SL Controller State	17-26	SSI Data Format
12-98	Interface Counters	14-42	Minimum AEO Frequency	16-39	Control Card Temp.	17-34	HIPERFACE Baud rate
12-99	Media Counters	14-43	Motor Cos Phi	16-40	Logging Buffer Full	17-5*	Resolver Interface
13-3**	Smart Logic	14-5*	Environment	16-41	LCP Bottom Status:line	17-50	Poles
13-0*	SLC Settings	14-50	RFI Filter	16-45	Motor Phase U Current	17-51	Input Voltage
13-00	SL Controller Mode	14-51	DC Link Compensation				
13-01	Start Event	14-52	Fan Control				

17-52	Input Frequency	31-01	Bypass Start Time Delay	32-8*	Velocity & Accel.	33-53	Terminal X57/4 Digital Input	34-5*	Process Data
17-53	Transformation Ratio	31-02	Bypass Trip Time Delay	32-80	Maximum Velocity (Encoder)	33-54	Terminal X57/5 Digital Input	34-50	Actual Position
17-56	Encoder Sim. Resolution	31-03	Test Mode Activation	32-81	Shortest Ramp	33-55	Terminal X57/6 Digital Input	34-51	Commanded Position
17-59	Resolver Interface	31-10	Bypass Status Word	32-82	Ramp Type	33-56	Terminal X57/7 Digital Input	34-52	Actual Master Position
17-60	Monitoring and App.	31-11	Bypass Running Hours	32-83	Velocity Resolution	33-57	Terminal X57/8 Digital Input	34-53	Slave Index Position
17-66	Feedback Direction	31-19	Remote Bypass Activation	32-84	Default Velocity	33-58	Terminal X57/9 Digital Input	34-54	Master Index Position
17-61	Feedback Signal Monitoring	32-*	MCO Basic Settings	32-85	Default Acceleration	33-59	Terminal X57/10 Digital Input	34-55	Curve Position
17-7*	Absolute Position	32-0*	Encoder 2	32-86	Acc. up for limited jerk	33-60	Terminal X59/1 and X59/2 Mode	34-56	Track Error
17-70	Absolute Position Display Unit	32-00	Incremental Signal Type	32-87	Acc. down for limited jerk	33-61	Terminal X59/1 Digital Input	34-57	Synchronizing Error
17-71	Absolute Position Display Scale	32-01	Incremental Resolution	32-88	Dec. up for limited jerk	33-62	Terminal X59/2 Digital Input	34-58	Actual Velocity
17-72	Absolute Position Numerator	32-02	Absolute Protocol	32-89	Dec. down for limited jerk	33-63	Terminal X59/1 Digital Output	34-59	Actual Master Velocity
17-73	Absolute Position Denominator	32-03	Absolute Resolution	32-9*	Development	33-64	Terminal X59/2 Digital Output	34-60	Synchronizing Status
17-74	Absolute Position Offset	32-04	Absolute Encoder Baud Rate X55	32-90	Debug Source	33-65	Terminal X59/3 Digital Output	34-61	Axis Status
18-*	Data Readouts 2	32-05	Absolute Encoder Data Length	33-*	MCO Adv. Settings	33-66	Terminal X59/4 Digital Output	34-62	Program Status
18-3*	Analog Readouts	32-06	Absolute Encoder Clock Frequency	33-00	Home Motion	33-67	Terminal X59/5 Digital Output	34-64	MCO 302 Status
18-36	Analog Input X48/2 [mA]	32-07	Absolute Encoder Clock Generation	33-00	Force HOME	33-68	Terminal X59/6 Digital Output	34-65	MCO 302 Control
18-37	Temp. Input X48/4	32-08	Absolute Encoder Cable Length	33-01	Zero Point Offset from Home Pos.	33-69	Terminal X59/7 Digital Output	34-7*	Diagnosis readouts
18-38	Temp. Input X48/7	32-09	Encoder Monitoring	33-02	Ramp for Home Motion	33-70	Terminal X59/8 Digital Output	34-70	MCO Alarm Word 1
18-39	Temp. Input X48/10	32-10	Rotational Direction	33-03	Velocity of Home Motion	33-70	Terminal X59/8 Digital Output	34-71	MCO Alarm Word 2
18-5*	Active Alarms/Warnings	32-11	User Unit Denominator	33-04	Behavior during Home Motion	33-80	Activated Program Number	35-*	Sensor Input Option
18-55	Active Alarm Numbers	32-12	User Unit Numerator	33-1*	Synchronization	33-81	Power-up State	35-0*	Temp. Input Mode
18-56	Active Warning Numbers	32-13	Enc.2 Control	33-10	Sync Factor Master	33-82	Drive Status Monitoring	35-00	Term. X48/4 Temperature Unit
18-6*	Inputs & Outputs 2	32-14	Enc.2 node ID	33-11	Sync Factor Slave	33-83	Behaviour after Error	35-01	Term. X48/4 Input Type
18-60	Digital Input 2	32-15	Enc.2 CAN guard	33-12	Position Offset for Synchronization	33-84	Behaviour after Esc.	35-02	Term. X48/7 Temperature Unit
18-9*	PID Readouts	32-16	Encoder 1	33-13	Accuracy Window for Position Sync.	33-85	MCO Supplied by External 24 VDC	35-03	Term. X48/7 Input Type
18-90	Process PID Error	32-30	Incremental Signal Type	33-14	Relative Slave Velocity Limit	33-86	Terminal at alarm	35-04	Term. X48/10 Temperature Unit
18-91	Process PID Output	32-31	Incremental Resolution	33-15	Marker Number for Master	33-87	Terminal state at alarm	35-05	Term. X48/10 Input Type
18-92	Process PID Clamped Output	32-32	Absolute Protocol	33-16	Marker Number for Slave	33-88	Status word at alarm	35-06	Temperature Sensor Alarm Function
18-93	Process PID Gain Scaled Output	32-33	Absolute Resolution	33-17	Master Marker Distance	33-9*	MCO Port Settings	35-1*	Temp. Input X48/4
30-*	Special Features	32-35	Absolute Encoder Data Length	33-18	Slave Marker Distance	33-90	X62 MCO CAN Node ID	35-14	Term. X48/4 Filter Time Constant
30-0*	Wobbler	32-36	Absolute Encoder Clock Frequency	33-19	Master Marker Type	33-91	X62 MCO CAN Baud Rate	35-15	Term. X48/4 Temp. Monitor
30-00	Wobble Mode	32-37	Absolute Encoder Clock Generation	33-20	Slave Marker Type	33-94	X60 MCO RS485 Serial Termination	35-16	Term. X48/4 Low Temp. Limit
30-01	Wobble Delta Frequency [Hz]	32-38	Absolute Encoder Cable Length	33-21	Master Marker Tolerance Window	33-95	X60 MCO RS485 Serial Baud Rate	35-17	Term. X48/4 High Temp. Limit
30-02	Wobble Delta Frequency [%]	32-39	Encoder Monitoring	33-22	Slave Marker Tolerance Window	34-0*	MCO Data Readouts	35-2*	Temp. Input X48/7
30-03	Wobble Delta Freq. Scaling Resource	32-40	Encoder Termination	33-23	Start Behavior for Marker Sync	34-01	PCD Write Par.	35-24	Term. X48/7 Filter Time Constant
30-04	Wobble Jump Frequency [Hz]	32-43	Enc.1 Control	33-24	Marker Number for Fault	34-02	PCD 1 Write to MCO	35-25	Term. X48/7 Temp. Monitor
30-05	Wobble Jump Frequency [%]	32-44	Enc.1 node ID	33-25	Marker Number for Ready	34-03	PCD 2 Write to MCO	35-26	Term. X48/7 Low Temp. Limit
30-06	Wobble Jump Time	32-45	Enc.1 CAN guard	33-26	Velocity Filter	34-04	PCD 3 Write to MCO	35-27	Term. X48/7 High Temp. Limit
30-07	Wobble Sequence Time	32-5*	Feedback Source	33-27	Offset Filter Time	34-05	PCD 4 Write to MCO	35-3*	Temp. Input X48/10
30-08	Wobble Up/Down Time	32-50	Source Slave	33-28	Marker Filter Configuration	34-06	PCD 5 Write to MCO	35-34	Term. X48/10 Filter Time Constant
30-09	Wobble Random Function	32-51	MCO 302 Last Will	33-29	Filter Time for Marker Filter	34-07	PCD 6 Write to MCO	35-35	Term. X48/10 Temp. Monitor
30-10	Wobble Ratio	32-52	Source Master	33-30	Maximum Marker Correction	34-08	PCD 7 Write to MCO	35-36	Term. X48/10 Low Temp. Limit
30-11	Wobble Random Ratio Max.	32-6*	PID Controller	33-31	Synchronization Type	34-09	PCD 8 Write to MCO	35-37	Term. X48/10 High Temp. Limit
30-12	Wobble Random Ratio Min.	32-60	Proportional factor	33-32	Feed Forward Velocity Adaptation	34-10	PCD 9 Write to MCO	35-4*	Analog Input X48/2
30-19	Wobble Delta Freq. Scaled	32-61	Derivative factor	33-33	Velocity Filter Window	34-2*	PCD Read Par.	35-42	Term. X48/2 Low Current
30-2*	Adv. Start Adjust	32-62	Integral factor	33-34	Slave Marker filter time	34-21	PCD 1 Read from MCO	35-43	Term. X48/2 High Current
30-20	High Starting Torque Time [s]	32-63	Limit Value for Integral Sum	33-40	Behavior at End Limit Switch	34-22	PCD 2 Read from MCO	35-44	Term. X48/2 Low Ref/Feedb. Value
30-21	High Starting Torque Current [%]	32-65	PID Bandwidth	33-41	Negative Software End Limit	34-23	PCD 3 Read from MCO	35-45	Term. X48/2 High Ref/Feedb. Value
30-22	Locked Rotor Protection	32-66	Velocity Feed-Forward	33-42	Positive Software End Limit	34-24	PCD 4 Read from MCO	35-46	Term. X48/2 Filter Time Constant
30-23	Locked Rotor Detection Time [s]	32-67	Acceleration Feed-Forward	33-43	Negative Software End Limit Active	34-25	PCD 5 Read from MCO	42-*	Safety Functions
30-24	Locked Rotor Detection Speed Error [%]	32-68	Max. Tolerated Position Error	33-44	Positive Software End Limit Active	34-26	PCD 6 Read from MCO	42-1*	Speed Monitoring
30-8*	Compatibility (I)	32-69	Reverse Behavior for Slave	33-45	Time in Target Window	34-27	PCD 7 Read from MCO	42-10	Measured Speed Source
30-80	d-axis Inductance (Ld)	32-70	Sampling Time for PID Control	33-46	Target Window LimitValue	34-28	PCD 8 Read from MCO	42-12	Encoder Resolution
30-81	Brake Resistor (ohm)	32-71	Size of the Control Window (Activation)	33-47	Size of Target Window	34-29	PCD 9 Read from MCO	42-13	Encoder Direction
30-83	Speed PID Proportional Gain	32-72	Size of the Control Window (Deact.v)	33-5*	I/O Configuration	34-30	PCD 10 Read from MCO	42-14	Feedback Type
30-84	Process PID Proportional Gain	32-73	Size of the Control Window	33-50	Terminal X57/1 Digital Input	34-4*	Inputs & Outputs	42-15	Feedback Filter
31-*	Bypass Option	32-74	Integral limit filter time	33-51	Terminal X57/2 Digital Input	34-40	Digital Inputs	42-17	Tolerance Error
31-00	Bypass Mode	32-74	Position error filter time	33-52	Terminal X57/3 Digital Input	34-41	Digital Outputs	42-18	Zero Speed Timer

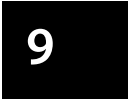

42-19	Zero Speed Limit	99-12	Fan
42-2*	Safe Input	99-1*	Software Readouts
42-20	Safe Function	99-13	Idle time
42-21	Type	99-14	Paramdb requests in queue
42-22	Discrepancy Time	99-15	Secondary Timer at Inverter Fault
42-23	Stable Signal Time	99-16	No. of Current Sensors
42-24	Restart Behavior	99-17	tCon1 time
42-3*	General	99-18	tCon2 time
42-30	External Failure Reaction	99-19	Time Optimize Measure
42-31	Reset Source	99-2*	Heatsink Readouts
42-33	Parameter Set Name	99-20	HS Temp. (PC1)
42-35	S-CRC Value	99-21	HS Temp. (PC2)
42-36	Level 1 Password	99-22	HS Temp. (PC3)
42-4*	SSI	99-23	HS Temp. (PC4)
42-40	Type	99-24	HS Temp. (PC5)
42-41	Ramp Profile	99-25	HS Temp. (PC6)
42-42	Delay Time	99-26	HS Temp. (PC7)
42-43	Delta T	99-27	HS Temp. (PC8)
42-44	Deceleration Rate	99-3*	Performance Readouts
42-45	Delta V	99-34	Perf FastThread AOC
42-46	Zero Speed	99-35	Perf SlowThread AOC
42-47	Ramp Time	99-36	Perf IdleThread AOC
42-48	S-ramp Ratio at Decel. Start	99-37	Perf SystemIdleThread AOC
42-49	S-ramp Ratio at Decel. End	99-38	Perf CPU usage AOC (%)
42-5*	SLS	99-39	Performance IntervalCounter
42-50	Cut Off Speed	99-4*	Software Control
42-51	Speed Limit	99-40	StartupWizardState
42-52	Fail Safe Reaction	99-41	Performance Measurements
42-53	Start Ramp	99-5*	PC Debug
42-54	Ramp-down Time	99-50	PC Debug Selection
42-6*	Safe Fieldbus	99-51	PC Debug 0
42-60	Message Selection	99-52	PC Debug 1
42-61	Destination Address	99-53	PC Debug 2
42-8*	Status	99-54	PC Debug 3
42-80	Safe Option Status	99-55	PC Debug 4
42-81	Safe Option Status 2	99-56	Fan 1 Feedback
42-82	Safe Control Word	99-57	Fan 2 Feedback
42-83	Safe Status Word	99-58	PC Auxiliary Temp
42-85	Active Safe Func.	99-59	Power Card Temp.
42-86	Safe Option Info	99-8*	RTDC
42-88	Supported Customization File Version	99-80	tCon1 Selection
42-89	Customization File Version	99-81	tCon2 Selection
42-9*	Special	99-82	Trig Compare Selection
42-90	Restart Safe Option	99-83	Trig Compare Operator
99-*	Devel support	99-84	Trig Compare Operand
99-0*	DSP Debug	99-85	Trig Start
99-00	DAC 1 selection	99-86	Pre-trigger
99-01	DAC 2 selection	99-9*	Internal Values
99-02	DAC 3 selection	99-90	Options present
99-03	DAC 4 selection	99-91	Motor Power Internal
99-04	DAC 1 scale	99-92	Motor Voltage Internal
99-05	DAC 2 scale	99-93	Motor Frequency Internal
99-06	DAC 3 scale	600-*	PROIsafe
99-07	DAC 4 scale	600-22	PROFIdrive/safe Tel. Selected
99-08	Test param 1	600-44	Fault Message Counter
99-09	Test param 2	600-47	Fault Number
99-10	DAC Option Slot	600-52	Fault Situation Counter
99-1*	Hardware Control	601-*	PROFIdrive 2
99-11	RPI 2	601-22	PROFIdrive Safety Channel Tel. No.

Index

A		Control	
Abbreviation.....	73	card.....	52
AC input.....	7, 31	Control card	
AC line power.....	7, 31	Performance.....	69
AC line voltage.....	37, 49	RS485 serial communication.....	67
AC waveform.....	7	Control characteristic.....	69
Additional resources.....	3	Control signal.....	49
Alarm log.....	37	Control terminal.....	38, 40, 49, 51
Alarms.....	51	Control wiring.....	12, 15, 33, 35
AMA.....	49, 53, 56	Control word timeout.....	54
AMA with T27 connected.....	41	Convention.....	73
AMA without T27 connected.....	41	Cooling.....	10
Ambient condition.....	65	Cooling clearance.....	35
Analog input.....	32, 66	Current limit.....	61
Analog output.....	32, 67	Current rating.....	52
Analog signal.....	52		
Analog speed reference.....	42	D	
Approval.....	7	DC current.....	7, 12, 49
Auto on.....	40, 49, 50	DC link.....	52
Auto On.....	38	Default setting.....	39
Automatic Motor Adaptation (AMA).....	41	Digital input.....	33, 50, 53, 66
Auto-reset.....	36	Digital output.....	68
Auxiliary equipment.....	35	Dimension, shipping.....	71, 72
		Discharge time.....	8
		Disconnect switch.....	36
B		E	
Block diagram.....	7	Efficiency.....	62, 63, 64
Brake		Electrical interference.....	13
control.....	53	EMC.....	12
limit.....	54	EMC interference.....	15
resistor.....	52	Energy efficiency class.....	65
Braking.....	49	Extended options cabinet.....	5
		External alarm reset.....	44
		External command.....	51
		External commands.....	7
		External controller.....	3
C		F	
Cable length and cross-section.....	66	Fault log.....	37
Cable routing.....	35	FC.....	34
Cable specification.....	66	Feedback.....	33, 35, 49, 56
Certification.....	7	Floating delta.....	31
Circuit breaker.....	35, 69	FLUX.....	46
Clearance requirement.....	10	Fuse.....	12, 35, 55, 69
Closed-loop.....	33		
Communication option.....	55		
Conduct.....	35		

G		M	
Ground connection.....	35	Main menu.....	37
Ground wire.....	12	Maintenance.....	48
Grounded delta.....	31	Manual initialization.....	39
Grounding.....	15, 31, 35, 36	MCT 10.....	32, 36
H		Mechanical brake control.....	46
Hand on.....	38, 49	Menu key.....	37
Harmonics.....	7	Menu structure.....	37
Heatsink.....	56	Modbus RTU.....	34
High voltage.....	8, 36	Motor	
I		current.....	56
Initialization.....	39	data.....	53, 57
Input current.....	31	power.....	56
Input disconnect.....	31	thermistor.....	45
Input power.....	7, 12, 15, 31, 35, 36, 51	Thermistor.....	45
Input power wiring.....	35	Motor cable.....	15
Input signal.....	33	Motor connection.....	15
Input terminal.....	31, 33, 36	Motor current.....	7, 37
Input voltage.....	36	Motor data.....	61
Inputs		Motor output (U, V, W).....	65
Analog input.....	52	Motor power.....	12, 37
Installation.....	33, 34, 35	Motor protection.....	3
Installation environment.....	10	Motor rotation check.....	40
Intended use.....	3	Motor speed.....	39
Interference isolation.....	35	Motor status.....	3
Interior view.....	4	Motor thermal protection.....	45
Intermediate circuit.....	52	Motor wiring.....	15, 35
Isolated main.....	31	Mounting.....	11, 35
J		N	
Jumper.....	33	Nameplate.....	10
L		Navigation key.....	37, 39, 49
Leakage current.....	9, 12	O	
Lifting.....	11	Open-loop.....	33, 46, 69
Line power supply (L1, L2, L3).....	65	Operation key.....	37
Load share.....	71	Optional equipment.....	33, 36
Load sharing.....	8	Output current.....	49, 52, 68
Local control.....	36, 38, 49	Output power wiring.....	35
Local control panel (LCP).....	36	Output terminal.....	36
		Overcurrent protection.....	12
		Overheating.....	53
		Overtemperature.....	53
		Overvoltage.....	50, 61

P		Specifications.....	34
Parameter menu structure.....	74	Speed reference.....	33, 40, 42, 49
PELV.....	45, 68	Speed reference, analog.....	42
Phase loss.....	52	Start/stop command.....	43
Potential equalization.....	13	Start-up.....	39
Power connection.....	12	Status display.....	48
Power factor.....	7, 35	Status mode.....	48
Programming.....	33, 36, 37, 38	STO.....	34
Pulse input.....	67	Storage.....	10
Pulse start/stop.....	43	Supply voltage.....	31, 32, 36, 55, 67
		Switch.....	33
Q		Switching frequency.....	50
Qualified personnel.....	8	Symbol.....	73
Quick menu.....	37	System feedback.....	3
R		T	
Ramp-down time.....	61	Terminal 53.....	33
Ramp-up time.....	61	Terminal 54.....	33
Reference.....	37, 41, 49, 50	Terminal location, D1h.....	16
Relay output.....	68	Terminal location, D2h.....	17
Remote command.....	3	Terminal location, D3h.....	17
Remote reference.....	50	Terminal location, D4h.....	18
Reset.....	36, 37, 38, 39, 51, 52, 53, 57	Terminals	
RFI filter.....	31	Input.....	52
RMS current.....	7	Terminal 54.....	58
RS485.....	45	Thermal protection.....	7
RS485 serial communication.....	34	Thermistor.....	31
Run command.....	40	Thermistor control wiring.....	31
Run permissive.....	50	Torque.....	53
		Torque characteristic.....	65
		Torque limit.....	61
		Torque, terminal.....	71
		Transient protection.....	7
S		Trip.....	45
Safe Torque Off.....	34	Trip lock.....	51
Safety.....	9	Trips.....	51
Serial communication.....	32, 38, 49, 50, 51	Troubleshooting.....	61
Service.....	48		
Setpoint.....	50	U	
Set-up.....	37, 40	Unintended motor rotation.....	9
Shielded cable.....	15, 35	Unintended start.....	8, 48
Shipping dimension.....	71, 72		
Short circuit.....	54	V	
Short circuit current rating (SCCR).....	70	Voltage imbalance.....	52
SLC.....	0, 46		
Sleep mode.....	50		

W

Warnings.....	51
Weight.....	71, 72
Windmilling.....	9
Wire size.....	12, 15



Danfoss Drives

4401 N. Bell School Rd.
Loves Park IL 61111 USA
Phone: 1-800-432-6367
1-815-639-8600
Fax: 1-815-639-8000
www.danfossdrives.com

Danfoss Drives

8800 W. Bradley Rd.
Milwaukee, WI 53224 USA
Phone: 1-800-621-8806
1-414-355-8800
Fax: 1-414-355-6117
www.danfossdrives.com

.....
Danfoss shall not be responsible for any errors in catalogs, brochures or other printed material. Danfoss reserves the right to alter its products at any time without notice, provided that alterations to products already on order shall not require material changes in specifications previously agreed upon by Danfoss and the Purchaser. All trademarks in this material are property of the respective companies. Danfoss and the Danfoss logotype are trademarks of Danfoss A/S. All rights reserved.
.....

Danfoss A/S
Ulsnaes 1
DK-6300 Graasten
vlt-drives.danfoss.com

