

Brochure

ENGINEERING
TOMORROW

Danfoss

How to select a **counterbalance valve**





Danfoss counterbalance valves

Introduction

Counterbalance valves play an integral role in the important task of safely controlling an actuator that may be holding a load or a person in the air. They help manage pressure created by impacts and loads to help stabilize loads, avoid equipment damage, cope with hose failure, and more.

Stopping runaway loads

Standard counterbalance valves help prevent static or dynamic loads from uncontrolled or uninitiated movement.

Handling induced pressure

In applications where pressure spikes are created by the operation of the machine, part-balanced counterbalance valves help avoid equipment damage by allowing line relief valves to operate normally.

Managing high or variable back pressure

Fully balanced relief valves help stabilize systems that have very high or experience large variations in back pressure.

Compensating for high system instability

Two-stage valves create stability in machinery with high intrinsic instability.

Providing hose burst protection

BoomLoc valves play a role in raising and lowering loads, and limit load speed in cases of hose failure. All the above will hold the load, control the load, and provide load safety in the event of hose failure.

Selection criteria

When selecting counterbalance valves, hydraulics engineers are faced with a difficult but important task. These small valves provide an important safety function in applications where safe and stable load handling is critical. They are often asked to deal with high pressure, large flows, or operate in extreme environments. Reducing instability can improve productivity and safety in an array of hydraulic systems. Choosing the perfect counterbalance valve for these dynamic systems presents a challenging task.

There are many options, and few people really understand them all. This has led people to select a valve from a familiar supplier without really questioning or understanding their choice or the options they have.

Danfoss can help solve this problem with the broadest portfolio of counterbalance valves in the industry. This will control costs while helping you find the best valve for the job.

What function do load holding valves provide?

To understand how to apply a counterbalance valve, it is important to understand how they work. Counterbalance valves—when placed between a directional control and the head or rod end of a cylinder—play an integral role in the important task of safely controlling an actuator that may be holding a load or a person in the air. They work in three distinct ways to ensure success while raising, lowering, and holding loads during linear or rotary motion.

1. **Load holding:** Counterbalance valves prevent the cylinder from unwanted downward drift. This function is referred to load holding and is critically important in aerial work platforms. The valve allows operators to raise or lower the boom at their desired rate and hold it in position. The load is raised through an integral free flow check which allows flow from the directional valves to the cylinder but prevents flow in the reverse direction.
2. **Load control:** Counterbalance valves also control loads by preventing actuators from running ahead of the pump due to energy created by the load. This function prevents loss of control and damage to the actuator caused by cavitation.
3. **Load safety:** Finally, in cases where a line breaks, a load holding valve directly mounted to the actuator will prevent uncontrolled and unsafe load motion.

How do the relief valves provide counterbalance to the actuator?

A counterbalance valve can easily be described as a pilot operated relief valve with a free flow check. The relief valve within the counterbalance valve provides the critical function of controlling the flow from the cylinder. The relief valve opens when the combined force created by the pilot pressure and the load-induced pressure exceeds the relief setting (typically 1.3 times the maximum load pressure).

The valve continually meters flow and controls descent. If the load begins to run away or shows signs of instability, the pressure in the pilot line will fall, causing the valve to restrict the flow exiting the actuator and preventing load runaway.

In the following pages, we will take a look at various tasks that can be performed by counterbalance valves, specific applications in which different valve types may be used, and the types of valves best suited to each task.

Basic counterbalance application

Standard Counterbalance Valve (Danfoss 1CE)

For most applications, the most cost-effective solution is to use the basic load holding valve such as the Danfoss 1CE series. These valves are suitable for use with static or dynamic loads when trying to stop a load from drifting or running away.

A common example is a cherry picker, where the load is often a person. The basic task is to raise and hold the person in the air for a period of time while work is being performed. Then return them safely to the ground.

If instability is occurring while using a standard counterbalance valve, consider changing the valve's pilot ratio.

Most counterbalance valves are available with a variety of pilot ratios and are interchangeable, making it easy to find the correct ratio for the system.



Selecting a pilot ratio

In general, higher pilot ratios work well for consistent, stable loads and lower pilot ratios for unstable or variable loads. The pilot ratio does not necessarily have a substantial impact on the working pressure, because the normal working pressure for a system is often higher than the pilot pressure required to open the valve fully.

The graph below shows the pilot pressure required to open the valve at a given set pressure and a varying load pressure with different pilot ratios.

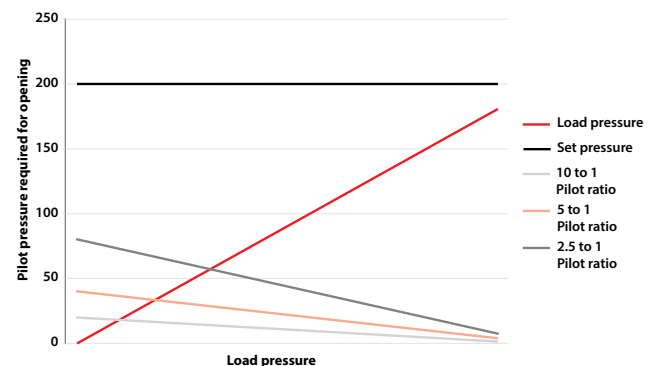

Instability results from rapid changes in the load pressure. In the chart above, you can see how a lower pilot ratio valve (2.5 to 1) has greater sensitivity to changes in the load pressure. In other words, if the load pressure suddenly increases, the operator will have to apply additional pilot pressure. A higher pilot ratio valve, with a flatter response, is more likely to open quickly when a sudden increase in load pressure occurs.

In the unlikely event that instability is still evident, by either audible squealing or bounce on initial movement, you may need to consider changing the valve design type. These are interchangeable making it easy to retrofit into the actuator or manifold.

Two types of relief function in counterbalance valves

If squealing is an issue, it may be the result of the construction of the relief valve within the counterbalance valve.

There are two main types of construction available in the market today: direct acting and differential area. The direct acting valve is based on the simplest form of relief valve design and provides stability through a wide range of pressures and flows. Danfoss' 1CE series valves are an example of how the direct acting construction provides improved stability over the differential area version of the valves.

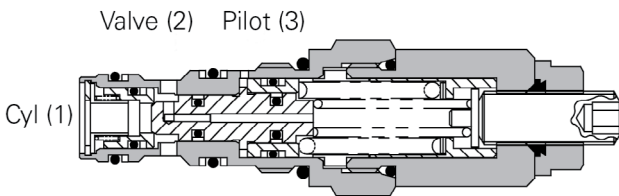

Direct acting valves take their name from the fact that the load pressure acts on the full area of the poppet. This style is a proven, simple, and traditional relief valve design. Because the pressure is applied to a large poppet area, greater spring force is required to meter and reseal the poppet. This spring force plays an important role in the metering of flow or what we refer to as the relief characteristic of the counterbalance valve.

Direct acting vs. Differential area

In contrast to direct acting valves, differential area designs are also available and widely used in the marketplace. They work by applying load pressure to a differential area between the poppet and the seat. This creates a smaller area for the load pressure to act upon.

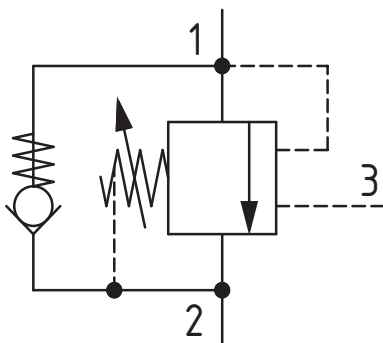

Because the poppet area is smaller with a differential area design, for a given load pressure, the poppet will require less spring force to meter and close the valve. This results in a valve that can meter large amounts of flow very rapidly. While this can be beneficial when dealing with very high flow applications, it can lead to instability and squealing in typical moderate flow hydraulic applications.

Direct acting valves are more stable because the heavier spring makes the poppet less reactive to small fluctuations in load pressure. This steeper relief characteristic, which prevents small pilot pressure changes from opening the valve quickly, provides in a stable and controlled metered flow.

Because they are designed for higher flow applications, differential area relief valves react more abruptly to changes in the pilot pressure. It takes only a small change in pilot pressure to increase the metered flow by a large amount, thus making the valve more unstable.

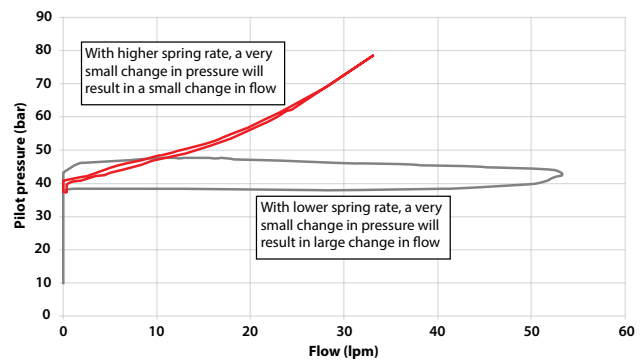

**Handling induced pressure
Closed center directional control valve
Use an OCV with a part balanced relief (1CER)**

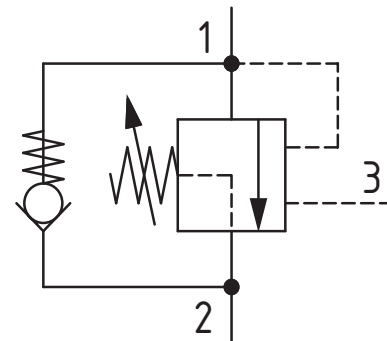

Some machines are designed using closed center directional valves while also requiring the use of counterbalance valves, such as a wheel loader. This brings additional challenges if the machine bucket is driven into a pile of rock, soil or manure on a worksite. Not only can pressure be captured between the directional and counterbalance valve, but a high induced pressure will result, and the cylinder will need to give in order to prevent mechanical damage.

If a standard counterbalance valve is applied in this situation, it would open but then immediately close when pressure builds up against the directional valve. It would require a tremendous amount of pilot pressure to open the counterbalance valve. The port reliefs on the directional valve would also be rendered inoperative.

It has become common in the industry to resolve this challenge by using a fully balanced valves with an atmospheric drain. While fully balanced valves help relieve the pressure, they are subject to contamination ingress and subsequent external leakage. A part balanced valve, such as Danfoss' 1CER, overcomes this issue and is essential for these types of applications. When pressure builds between the closed center directional valve and counterbalance valve,

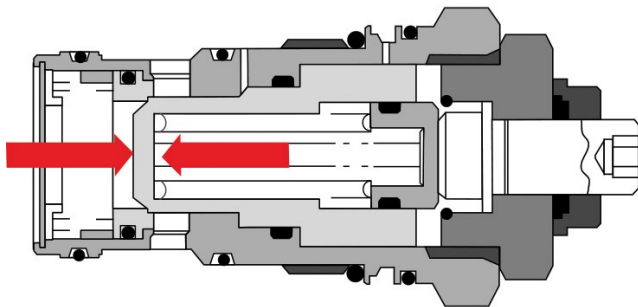

it is applied to the valve port of the counterbalance valve. To overcome the added pressure on the valve port, the part balanced 1CER references the added pressure to the spring chamber. This pressure is now acting on both ends of the poppet and becomes balanced or negates the effect of the backpressure on the valve port.

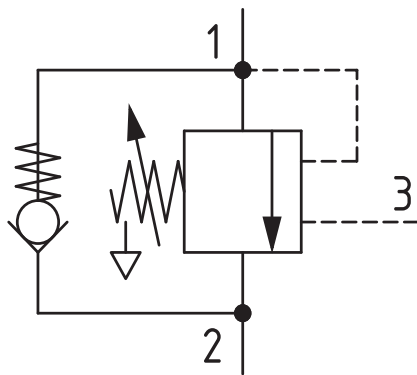

**Managing high or variable back pressure
Regenerative or proportional systems
Use a fully balanced relief valve (1CEB, 1CEBD)**

Many types of equipment with proportional systems create backpressure as described earlier with a closed center directional valve system. However, because the system is proportional, the backpressure created is often changing constantly, requiring a different approach to your application of counterbalance valves.

Cranes, for example, often use meter out proportional valves, creating a constantly varying back pressure between the directional control and counterbalance valve. This variable pressure creates a design challenge, and the solution has to be flexible enough to adapt to changing system conditions.



Regenerative systems are another common application that creates variable backpressure situations. These systems work by allowing flow to move from the rod end to the bore side of the cylinder enabling increase extension speed. A consequence, however, is the backpressure in the cylinder is constantly varying, again creating additional challenges in your counterbalance valves system.

If using a standard or part-balanced valve in one of these applications, the variable backpressure can cause either to become unstable by effectively changing the pilot pressure required to open the poppet. For these situations, a fully balanced relief valve is recommended to manage pressure fluctuations.

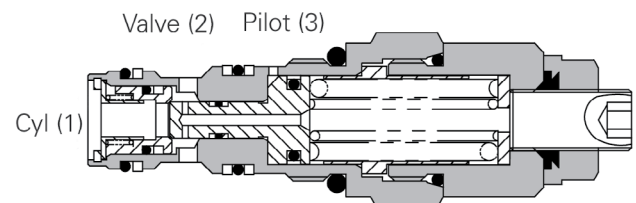

Danfoss' 1CEB and 1CEBD counterbalance valves provide fully balanced relief. Like the part balanced valves, the fully balanced valves reference pressure from the valve to the spring chamber. However, with the fully balanced valves, the pressure in the spring chamber is vented to the atmosphere or to a separate drain port. By venting the spring chamber, the pilot pressure required to open the valve is no longer variable and a stable counterbalance results.

In mobile applications, it is preferred to use the four-ported 1CEBD valve rather than the three-ported version, which is atmospherically vented. The additional port can be drained to tank, thus preventing contamination ingress into the valve which often causes seal damage and external leakage.

If you prefer to use a three ported fully balanced valve, consider valves using a sintered bronze filter for venting, as they better protect against contamination from entering the spring chamber and hydraulic system.



Two-Stage valves
Use a two-stage valve (1CEL)

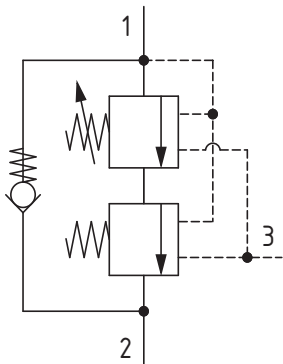

Another common challenge engineers face in the application of counterbalance valves are vehicles with a high degree of load dynamics. Vehicles with slender booms, multiple booms, wear pads with varying frictional forces, or pneumatic tires are all subject to higher levels of load dynamics.

Concrete pumps are a common example as they require multiple long, slender booms to deliver concrete to the work site. Rough terrain forklifts or telescopic handlers with pneumatic tires are other examples where machine dynamics require a high level of counterbalance valve.

Using the example of a telescopic boom, the long cylinder can act as a capacitor and store energy when fully extended. The pressure within the cylinder will rise to system pressure at the end of the stroke. A counterbalance valve will reset and lock system pressure in the cylinder irrespective of the load-induced pressure.

When the operator begins to lower the load, this stored energy gives the counterbalance valve the message that a heavy load is on the boom, and less pilot pressure is required to open the counterbalance valve. The valve opens very quickly and allows the stored energy to dissipate causing a momentary runaway condition or prompting the valve to overreact. The consequence of this is an initial instability as the boom is retracted.

Many vehicle engineers use restrictive and semi-restrictive valves in for application of highly dynamic vehicles. These valves work by introducing a restriction into system. While the restriction may effectively reduce instability by limiting flow, it is inherently inefficient and will generate heat.

A more efficient alternative to restrictive valves is a two-stage valve, such as Danfoss' 1CEL design. The two-stage valve maintains an initial counterbalance pressure when the valve is opened to prevent total decay of the stored energy within the cylinder. This is done

by maintaining the counterbalance pressure through the center poppet and inner spring. Once this energy is dissipated, the outer poppet and spring will behave the same way the pressure setting does in a standard counterbalance valve and reset the poppet if the load begins to run away or over-react.

By having a fixed outer spring and an adjustable inner spring, the two-stage valve allows you to establish a range of acceptable pressure settings that fit the specific application. For example, the valve could be required to be set at 200 bar (3000 psi) with a counterbalance pressure between 35 and 70 bar (500-1000 psi).

Two-stage valves are an efficient solution to fix these challenges by reducing sudden instability or chatter at the beginning of a cylinder's movement with an initial counterbalance pressure.

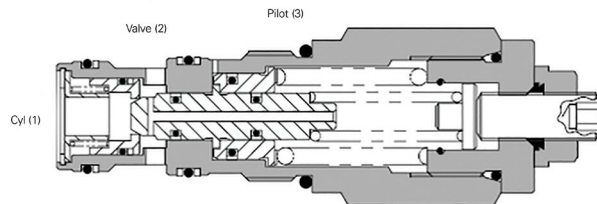

Providing hose burst protection
BoomLoc Hose Rupture Valves
Hose burst protection

While all counterbalance valves provide a level hose burst protection when applied correctly, BoomLoc hose rupture valves (HRVs) provide an added level of protection to meet ISO8643 requirements. These valves, such as Danfoss' 1CPB series, are specifically designed to work along with a directional valve to control motion, especially in cases where a hose fails.

You will commonly find HRVs on excavators. Just as with a standard counterbalance valve, the HRV allows free flow into the cylinder with minimal pressure loss when the load is being lifted. When controls are in neutral, the HRV closes to lock the pressure in the cylinder and locks the load in place. While the load is being held, a separate relief valve provides overload relief by returning flow to the tank via the main control valve port relief.

The most important feature of the HRV is how it helps mitigate issues caused by hose failure during lowering by limiting boom acceleration to twice its original speed.

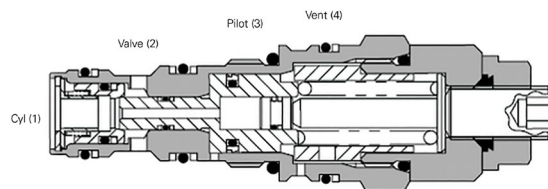

This is accomplished by hydraulically balancing the poppet without providing any relief function. Any over-pressure caused by shock or temperature changes is handled by an additional relief element.

The BoomLoc valve can be described as a piloted, metered poppet valve with a free flow check. It is different from other types of counterbalance valves in that the poppet is completely controlled by pilot pressure. Unlike other valves, the load pressure or back pressure does not affect the metering of the poppet. When placed directly on to the cylinder, it protects the load in the case of a hose failure and the operator can then bring the load to a safe condition to allow the hose to be changed.

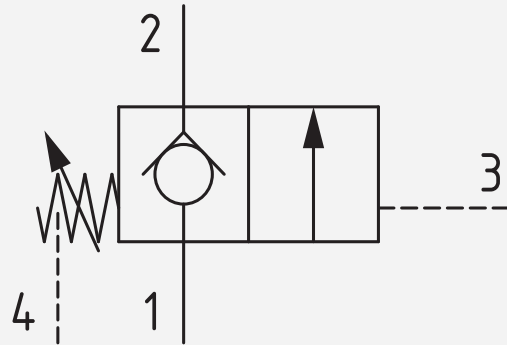

Conclusion

Counterbalance valves perform critical functions to help keep loads safe and stable.

We have taken a quick look at a few specific jobs performed by counterbalance valves, applications that use different types of valves, and the types of valves that are best for each job. In each case, Danfoss offers options that can help hydraulics engineers tackle design, requirement and cost challenges while providing superior stability and performance for load-holding applications.

For more information about how Danfoss' cartridge valves can help you, go to www.danfoss.com



ENGINEERING
TOMORROW



Danfoss Power Solutions, Nordborgvej 81, 6430 Nordborg, Denmark, Tel. +45 74 88 22 22, Fax +45 74 65 25 80
www.danfoss.com, E-mail: info@danfoss.com

Any information, including, but not limited to information on selection of product, its application or use, product design, weight, dimensions, capacity or any other technical data in product manuals, catalogues descriptions, advertisements, etc. and whether made available in writing, orally, electronically, online or via download, shall be considered informative, and is only binding if and to the extent, explicit reference is made in a quotation or order confirmation. Danfoss cannot accept any responsibility for possible errors in catalogues, brochures, videos and other material. Danfoss reserves the right to alter its products without notice. This also applies to products ordered but not delivered provided that such alterations can be made without changes to form, fit or function of the product. All trademarks in this material are property of Danfoss A/S or Danfoss group companies. Danfoss and the Danfoss logo are trademarks of Danfoss A/S. All rights reserved.