

Vickers® by Danfoss
Relief Valves



Balanced Piston Relief Valves

CG/CS/CS5-03/06/10 Series
CT/CT5/CG5-06/10 Series

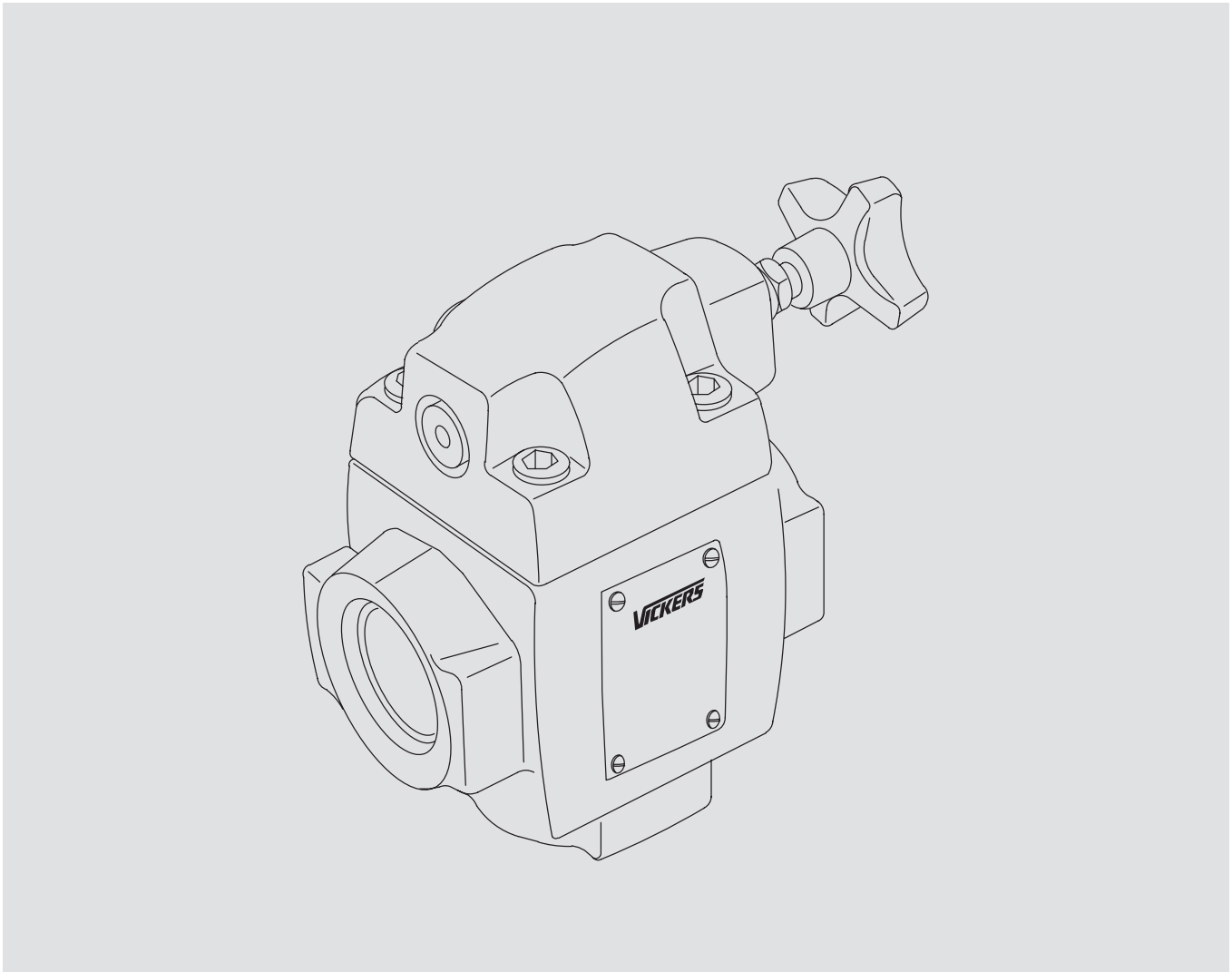

Table of Contents

Section	Page
I. Introduction.....	1
A. Purpose of Manual.....	1
B. Related Publications.....	1
C. Model Code.....	2
II. Description.....	2
A. General.....	2
B. Basic Parts.....	2
III. Principles of Operation.....	3
A. Pressure Relief.....	3
B. Venting.....	3
C. Remote Control.....	3
IV. Installation.....	4
A. Installation Drawings.....	4
B. Circuit Connections.....	4
C. Piping and Tubing.....	4
D. Fluids and Seals.....	4
V. Inspection and Maintenance.....	4
A. Inspection.....	4
B. Cleanliness.....	4
C. Adding Fluid to the System.....	4
D. Hydraulic Fluid Recommendations.....	5
E. Overload Protection.....	5
F. Product Life.....	5
G. Troubleshooting Chart.....	5
VI. Overhaul.....	5
A. Unit Removal.....	5
B. Service Tools.....	5
Standard Tools.....	5
C. Disassembly.....	6
D. Disassembly (C*5 Models).....	6
E. Inspection, Repair and Replacement.....	6
F. Assembly.....	8
VII. Start-Up and Test.....	8
A. Start-Up.....	8
B. Test.....	8

Section I – Introduction

A. Purpose Of Manual

This manual describes operational characteristics, maintenance requirements, and overhaul information for Vickers balance piston relief valves. The information contained herein pertains to the latest design series as listed in Table 1.

Model
CT/CS-10-**-30
CT/CS/CG-H10-**-30
CT/CS/CG-06-**-50
CT/CS/CG-H06-**-50
CS-03-**-50
CS5-03-***-***-90
CT5/CG5-*06/*10-***-***-90

Table 1

B. Related Publications

Service parts and installation dimensions are not contained in this manual. The parts and installation drawings listed in Table 2 is available from any Vickers application engineering office.

Model	Parts & Service Drawing	Installation Drawing	
CG-06-**-20	I-3302-S	510900	
CG-06-**-40	I-3306-S		
CG-06-**-50	I-3368-S		
CG-H06-*V-50	I-3366-S		
CG-H10-*V-30	I-3399-S		
CG-10-**-20	I-3301-S		
CG-10-**-30	I-3697-S		
CS-03-**-20	I-3301-S		
CS-03-**-40	I-3305-S		
CS-03-**-50	I-3369-S		
CS-06-**-20	I-3304-S	510500	
CS-H06-*V-50	I-3367-S		
CS-H10-*V-30	I-3699-S		
CS-10-**-20	I-3304-S		
CS-10-**-30	I-3698-S		
CT-06-**-20	I-3301-S		
CT-06-**-40	I-3305-S		
CT-06-**-50	I-3369-S		
CT-H06-*V-50	I-3367-S		
CT-H10-*V-30	I-3699-S		
CT-10-**-20	I-3301-S	511005	
CT-10-**-30	I-3698-S		
CS5-*03-***-***-70 *-***-70	I-3364-S		
CS5-*03-***-***-80 *-***-80	I-3679-S		
CS5-*03-***-***-81 *-***-81	I-3691-S		
CS5-*03-***-***-90 *-***-90			
CG5/CS5/CT5-*06-***-***-70	I-3364-S		511006
CG5/CS5/CT5-*06-***-***-80	I-3679-S		
CG5/CS5/CT5-*06-***-***-81	I-3691-S		
CG5/CS5/CT5-*10-***-***-70	I-3365-S		
CG5/CS5/CT5-*10-***-***-80/81	I-3680-S		
CG5/CS5/CT5-*10-***-***-90			

Table 2

C. Model Codes

Variations within each basic model series are covered in the model code. Table 3 is a complete breakdown of the model codes covering these units. Service inquiries should always include the complete unit model code as noted on the nameplate.

Model Code

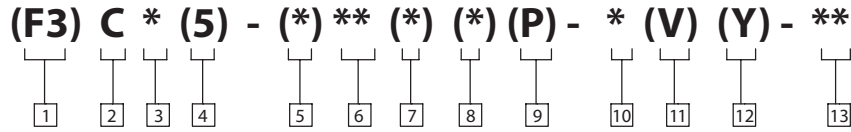

<p>1 Multi-fluid capability (Viton Seals)</p> <hr/> <p>2 Relief valve</p> <hr/> <p>3 Port connection G - Manifold or subplate mounted S - SAE straight thread T - NPTF Pipe Thread</p> <hr/> <p>4 Solenoid controlled (Pilot stage models only)</p> <hr/> <p>5 H - High flow (06/10 valve size only)</p>	<p>6 Valve size 03 - 3/8 inch 06 - 3/4 inch 10 - 1 1/4 inch</p> <hr/> <p>7 Spool function (Pilot stage models only)</p> <hr/> <p>8 Pilot stage (Solenoid controlled models only) A - Spring offset C - Spring centered</p> <hr/> <p>9 P - Manual override (‘A’ & ‘B’ pilot stage models only)</p>	<p>10 Pressure Range B - 125-1000 PSI C - 500-2000 PSI F - 1500-3000 PSI</p> <hr/> <p>11 Vent Pressure V - High vent Omitted - Standard & low vent models</p> <hr/> <p>12 External drain feature Y - Sequence Valve Omitted - Standard Relief</p> <hr/> <p>13 Design</p>
---	---	--

Table 3. Model Code Breakdown

Section II – Description

A. General

Relief valves are devices used to limit maximum pressure in hydraulic systems. When system pressure starts to exceed the pressure setting of the relief valve, a controlled amount of hydraulic fluid bypasses through the tank port and limits the system pressure to the valve setting. A fine incremented adjustment assures precise regulation over wide pressure ranges.

A Vickers relief valve provides a fast response with very low pressure override characteristics because of its two-stage balance piston design. The balance piston relief valve is so named because in normal operation it is in hydraulic balance. Further details are discussed in Section III.

B. Basic Parts

Relief valves consist of two sections: the cover section and the body section. The cover section includes a pressure adjustment screw, a heavy spring, a poppet, a seat, and a vent connection. The body section includes a piston, a light spring, a seat, and the port connections.

Section III – Principles of Operation

A. Pressure Relief

Figure 1 illustrates the basic valve operation. The valve pressure setting is determined by the adjusting screw position which varies the heavy spring compression. The balanced piston is normally held against the seat by the light spring. System pressure is present in chamber A and is connected to chamber B through orifice C.

The closed position of the valve is shown in Figure 1A. With system pressure less than the valve setting, the pilot poppet is held against its seat by spring force. Pressures in chambers A and B equalize through orifice C. Thus, the piston is hydraulically in balance and held against its seat by the light spring.

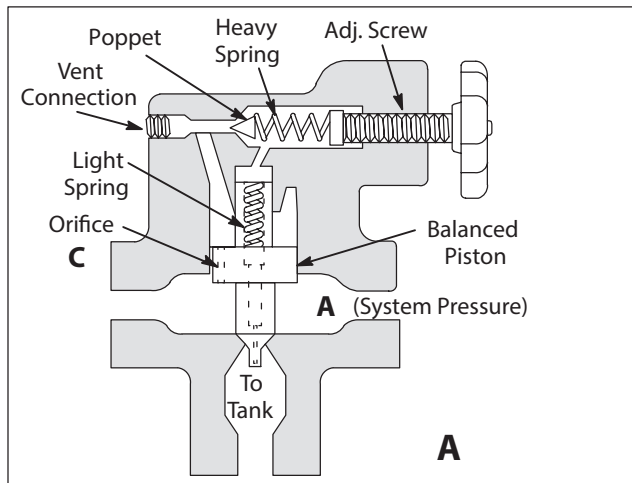

Figure 1A.

In Figure 1B the valve is shown throttling fluid to the tank port. This occurs when system pressure exceeds the heavy spring setting and forces the poppet away from its seat.

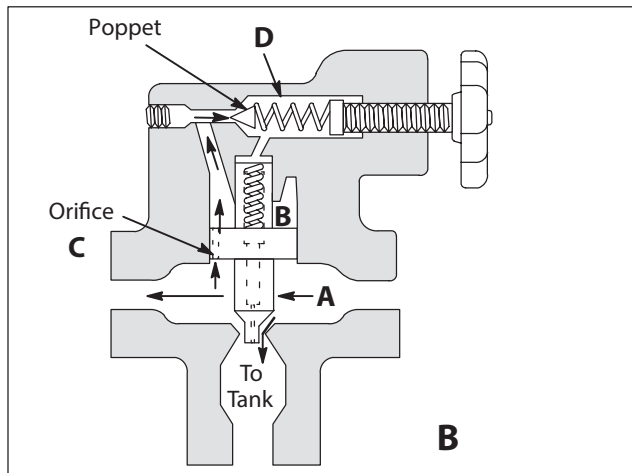

Figure 1B.

Fluid then flows through orifice C and chamber B, past the poppet into chamber D, and down through the drain hole in the center of the piston to the tank port.

The pressure in chamber B is limited by the setting of the heavy spring. When pressure in chamber A exceeds chamber B sufficiently, pressure unbalance overcomes the force of the light spring and lifts the piston. Excess fluid then flows past the bottom of the piston to tank.

When the system pressure drops below the valve setting, the poppet reseats. Control flow through orifice C stops and pressures in chambers A and B are again effectively equalized.

The light spring then forces the piston toward the seat while orifice C continues to equalize pressure between chambers A and B. When the balance piston is closed against its seat, all flow through orifice C stops.

B. Venting

The "High-Vent" option ("V" in the model code) is used when it is necessary to maintain pilot pressure for other valves in the system. This option provides a faster valve de-venting (closing) action. Higher pressure (approximately 80 PSIG) is maintained when the valve is vented because a heavier piston spring is used.

Relief valves can be vented to unload pump delivery to tank in the following manner:

Connect a shut-off valve to the vent port of the main relief valve. Chamber 'B' above the balanced piston can be opened to tank (see Figure 1B). This removes pressure at the top of the balanced piston. Pressure in chamber 'A' overcomes the light spring, unseats the balanced piston, and diverts all pump delivery to tank.

A solenoid controlled directional valve (C*5) may be used to vent flow to tank. This directional valve is mounted on top of a standard relief valve to form a single package. See Figure 6.

C. Remote Control

The main relief valve may be adjusted from a remote location by using another adjustable valve similar in function to the main relief valve pilot stage (see Figure 2). Flow past the poppet of the remote control valve is directed to tank. The following rules should be maintained for optimum results:

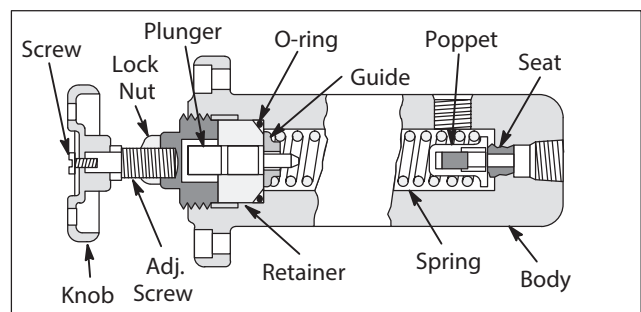

Figure 2.

1. Keep hydraulic lines (tubing) as short as possible.
2. Set main relief valve 200-300 PSIG above maximum operating pressure. DO NOT exceed the valve pressure rating.
3. Set remote control valve to maximum operating pressure.
4. Check system for stability characteristics. If the system is unstable, reduce the line length and/or proceed to step 5.
5. Install an orifice in the vent opening of the main relief valve cover and in the pressure port of the remote control valve. DO NOT go below 0.040 inch diameter or a malfunction could result. Orifices should be as large as possible to prevent excessive pressure drop and still maintain noise free operation.

Section IV – Installation

A. Installation Drawings

The installation drawings listed in Table 2 will show installation dimensions, port locations and operating parameters. Manifold, subplate and bolt kit information is also included.

NOTE

The tank line must be piped directly to tank to minimize back pressure. The drain line from the remotely operated valve (vent valve) must also be directly piped to tank. Any pressure in the drain line is additive to the pressure setting of the valve.

B. Circuit Connection

Threaded type CT/CS valves are usually connected directly in the pressure line. Circuit flow passes through the ports located on opposite sides of the valve body. The bottom port (opposite the cover) is the return flow port and is connected to tank. These valves may be teed into the pressure line by plugging or blocking one of the pressure outlet ports.

CG type gasket mounted valves are teed into pressure lines. The tee is connected to the pressure port of the valve sub-plate or manifold. The return port is connected to tank. The valve must be mounted against a flat, ported mounting surface.

Repair or replacement of CG valves is simplified in that piping need not be disturbed.

C. Piping And Tubing

1. All pipes and tubing must be thoroughly cleaned before installation. Recommended methods of cleaning are sandblasting, wire brushing and pickling.

NOTE

For instructions on pickling, refer to instruction sheet 1221 – S.

2. To minimize flow resistance and the possibility of leakage, only as many fittings and connections as are necessary for proper installation should be used.

3. The number of bends in tubing should be kept to a minimum to prevent excessive turbulence and friction of fluid flow. Tubing must not be bent too sharply. The recommended radius for bends is three times the inside diameter of the tube.

D. Fluids and Seals

Standard seals (Nitrile) can be used with petroleum, water glycols, and water-oil emulsion type fluids.

F3 seals (Viton*) can be used with all commonly used industrial hydraulic fluids. Viton is compatible with petroleum, water base and synthetic fire-resistant fluids.

*Trademark of Dupont De Nemours Co., Inc.

Section V – Service and Maintenance

A. Inspection

Periodic inspection of the fluid condition and tube or piping connections can save time-consuming breakdowns and unnecessary parts replacement. The following should be checked regularly.

1. All hydraulic connections must be kept tight. A loose connection in a pressure line will permit the fluid to leak out. If the fluid level becomes so low as to uncover the inlet pipe opening in the reservoir, extensive damage to system components can result. In suction or return lines, loose connections permit air to be drawn into the system resulting in noisy and/or erratic operation.

2. Air bubbles in the reservoir can ruin system components. If bubbles are seen, locate the source of the air and seal the leak.

B. Cleanliness

Clean fluid is the best insurance for long service life. Therefore, check the reservoir periodically for dirt and other contaminants. If the fluid becomes contaminated, flush the entire system and add new fluid.

To insure your hydraulic system is clean, perform the following steps:

1. Clean (flush) the entire system to remove paint,, metal chips, welding shot, etc.

2. Filter each oil change to prevent introduction of contaminants.

3. Provide continuous oil filtration to remove sludge, products of wear and corrosion generated during the life of the system.

4. Provide protection to all areas that can introduce airborne contaminants into the system.

5. Perform regular servicing procedures of filters, breathers, and reservoirs.

C. Adding Fluid to the System

When hydraulic fluid is added to replenish the system, pour it through a fine wire screen (200 mesh or finer). DO NOT use a cloth to strain the fluid because lint may enter the system. When applicable, pump the fluid through a 10 micron filter or use a PFTU (porta filter and transfer unit). For PFTU information, order bulletin 366.

D. Hydraulic Fluid Recommendations

Hydraulic fluid within the system performs the dual function of lubrication and transmission of power. To insure proper lubrication, system life, and component reliability, fluid selection should be made carefully with the assistance of a reputable supplier. Fluid selection should be acceptable for use with all valves, motors and pumps within the system.

Data sheet I-286-S for oil selection is available from Vickers Technical Publications, Troy, MI 48007-0302.

The fluid recommendations noted in the data sheet are based on our experience in industry as a hydraulic component supplier. Where special considerations indicate a need to depart from these recommendations, see your Vickers sales representative.

E. Overload Protection

A relief valve must be installed in the system as close to the pump as possible. The relief valve limits pressure in the system to a prescribed maximum. The setting of the relief valve depends on the work requirements of the system.

F. Product Life

The longevity of these products is dependent upon environment, duty cycle, operating parameters and system cleanliness. Since these parameters vary from application to application, the ultimate user must determine and establish the periodic maintenance required to maximize life and detect potential component failure.

G. Troubleshooting

Table 4 lists the common difficulties experienced with pumps and hydraulic systems. It also indicates probable causes and remedies for each of the troubles listed.

TROUBLE	PROBABLE CAUSE	REMEDY
Erratic pressure	Foreign matter in system	Drain, flush and refill system with clean fluid.
	Worn poppet or seat in cover	Replace poppet and seat.
	Piston sticking in body or cover	Clean piston. Remove burrs by light lapping. Check freedom of movement on reassembly. Replace if necessary.
Low pressure or no pressure	Valve improperly adjusted	Adjust valve to proper setting.
	Vent connection open	Plug vent connection.
	Balance hole in piston plugged	Remove piston and clean out. If necessary, drain system and refill with clean fluid.
	Poppet in cover not seating	Back off adjusting screw several turns while running pump to be certain foreign matter is not caught on the seat. Check condition of seat, spring, and poppet if malfunction persists.
Excessive noise or chatter	High oil velocity through valve	Check valve flow rating. Replace with larger valve if necessary.
	Distorted control spring	Replace spring.
	Worn poppet or seat in cover	Replace poppet and seat.
	Excessive tank line pressure	Connect return port directly to tank.
	Vent line too long	Place a restriction, eg. needle valve or orifice plug in vent line next to relief valve.
	Valve setting too close to that of system operating pressure	Set relief valve at least 150 PSI higher than other valves in circuit.

Table 4. Troubleshooting Chart

Section VI – Overhaul

A. Unit Removal



CAUTION

Before breaking a circuit connection, make certain that power is off and system pressure has been released. Lower all vertical cylinders, discharge accumulators, and block any load whose movement could generate pressure.

1. Remove relief valve from system.
2. Drain appropriate hydraulic lines and remove the valve from system.
3. Cap all system openings to prevent contamination.
4. Place the relief valve on a clean work bench.



CAUTION

Absolute cleanliness is essential when working on a hydraulic system. Always work in a clean area. The presence of dirt and foreign materials in the system can result in serious damage or inadequate operation.

B. Service Tools

The following tools are recommended to overhaul a CG, CS, CT, or C*5 relief valve:

Standard Tools and Equipment:

1. A 6 inch crescent wrench.
2. One set of hex key wrenches with a socket adaptor.
3. Petroleum jelly or grease that is compatible with hydraulic fluids.
4. Cleaning solvent.
5. A small ball peen hammer.
6. One medium size screwdriver.
7. One torque wrench (0-250 lb. in.)
8. A clean work bench that is equipped with a vise.
9. Shop air (90 psi).

Special Tools:

1. A piece of drill rod or roll steel to remove the seat within the valve body. See Figure 3.

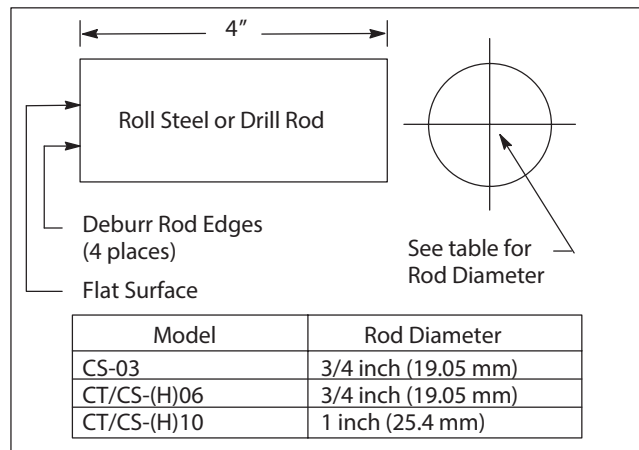

Figure 3. Disassembly Tool to Remove Seat (19) from Body (21)

2. One screw (approximately 4 inches long), two washers, and one nut. This particular tool is needed to remove the seat and/or sleeve from the body of CG (subplate mounted) models only. See Figure 4.

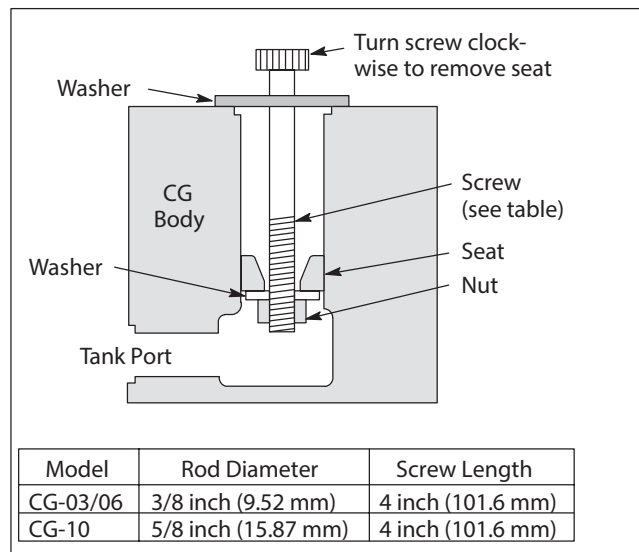

Figure 4. Seat (19) Removal Tool (CG Models)

C. Disassembly

Periodic maintenance of the relief valve will generally not require disassembly to the extent described here. However, the following disassembly sequence can be used as a guide for partial disassembly. In general, disassembly is accomplished by item number sequence shown in Figure 5.

1. Thoroughly clean the valve exterior with cleaning solvent.
2. Secure valve body (21) in a vise.
3. Loosen lock nut (2).

4. Turn knob (1) counterclockwise and remove knob from valve cover (14).

NOTE

An adjusting screw replaces the knob on C*5 models.)

5. Remove parts (3) through (8). Inspect poppet (8) for damage to sealing surface. If poppet (8) is damaged, replace with a new cover subassembly.

6. Inspect seat (12) for nicks, scratches, and washout. If the seat shows evidence of damage, replace with a new cover subassembly. DO NOT attempt to remove seat (12) from cover (14).

7. If seat (12) is in good condition, remove plug (9), seal (10), and spacer (11).

NOTE

Space (11) exists on C*-10-**-** models only.)

8. Remove four screws (13) from cover (14), then disassemble the cover from body (21).

9. Remove parts (15) through (18) from body (21). Inspect piston (18) sealing surface for heavy scratches and other damage. Discard seal (15).

10. If piston (18) is damaged, turn valve body (21) in vise so tank port faces up. Insert a rod (reference Figure 3) into the tank port against seat (19.) Tap on rod end with hammer and remove the seat (19) from body (21). For C*-H**-30/50 models, insert rod against sleeve (20) and remove sleeve and seat at the same time.

NOTE

The following step refers to CG models only.

11. If piston (18) is damaged, secure body (21) in vise so mounting surface is face up. Insert a screw through seat (19). See Section VI, B and Figure 4 for removal of seat (19).

12. Remove plug (22) from body (21). Remove seal (23) from plug (22).

13. Discard seals (6), (10), (15) and (23).

D. Disassembly (C*5 Models)

Except for removal of the solenoid operated directional valve, the disassembly sequence of a C*5 valve is essentially the same as a standard relief valve.

1. Remove the four nameplate screws (a) and loosen nameplate (b) from directional valve cover (c).

2. Loosen four screws (d) and remove directional valve (e) from valve cover (f).

3. Discard seals (g).

4. Disassemble the relief valve per Section VI, C and follow Figure 5.

NOTE

This manual does not cover the repair and/or overhaul of solenoid operated directional valves. If the directional valve causes the relief valve to become inoperative, obtain the necessary parts and service information for directional valves.

E. Inspection, Repair & Replacement

NOTE

All parts must be thoroughly cleaned and kept clean during inspection and assembly. The close tolerance of the parts makes this requirement very important.

NOTE

Reliable operation throughout the specified operating range is assured only if genuine Vickers parts are used. Sophisticated design processes and materials are used in the manufacture of our parts. Substitutions may result in early failure.

NOTE

Replace all parts that do not meet the following specifications.

1. Inspect all screws (13) for evidence of damaged threads. If threads are damaged, replace the screws.

2. Inspect springs (7), (16), and (17) for distortion or damaged coils. Replace springs if coils are damaged.

3. Inspect the piston (18) to cover (14) clearance. Insert the piston into the cover and check for looseness. A close tolerance fit is mandatory for proper valve operation. If a loose fit is noted, the cover is worn and must be replaced.

4. Inspect the piston (18) to body (21) clearance. The piston should have a close tolerance fit as noted in step 3. If the piston is loose inside the body bore, replace the body and seat (19).

5. Inspect piston (18) for nicks or scratches across the sealing surface. Make sure the balance hole in the piston is free from foreign material. Remove minor scratches on piston with 500 grit polishing paper. If the piston has heavy scratches, replace the piston (18), seat (19), and body (21).

6. Inspect poppet (8) and seat (12) for heavy wear or evidence of washout. Replace both the poppet and seat if heavy wear or washout is noted.

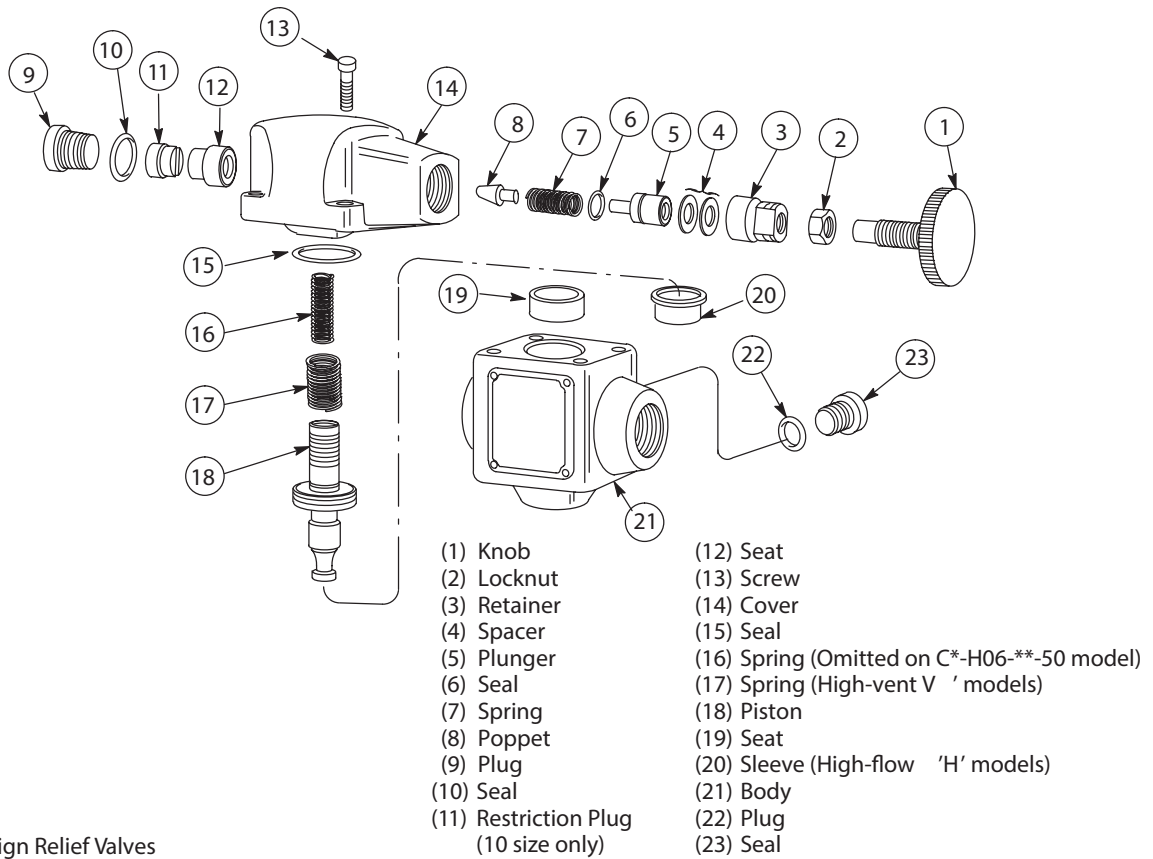

Figure 5. -50 Design Relief Valves

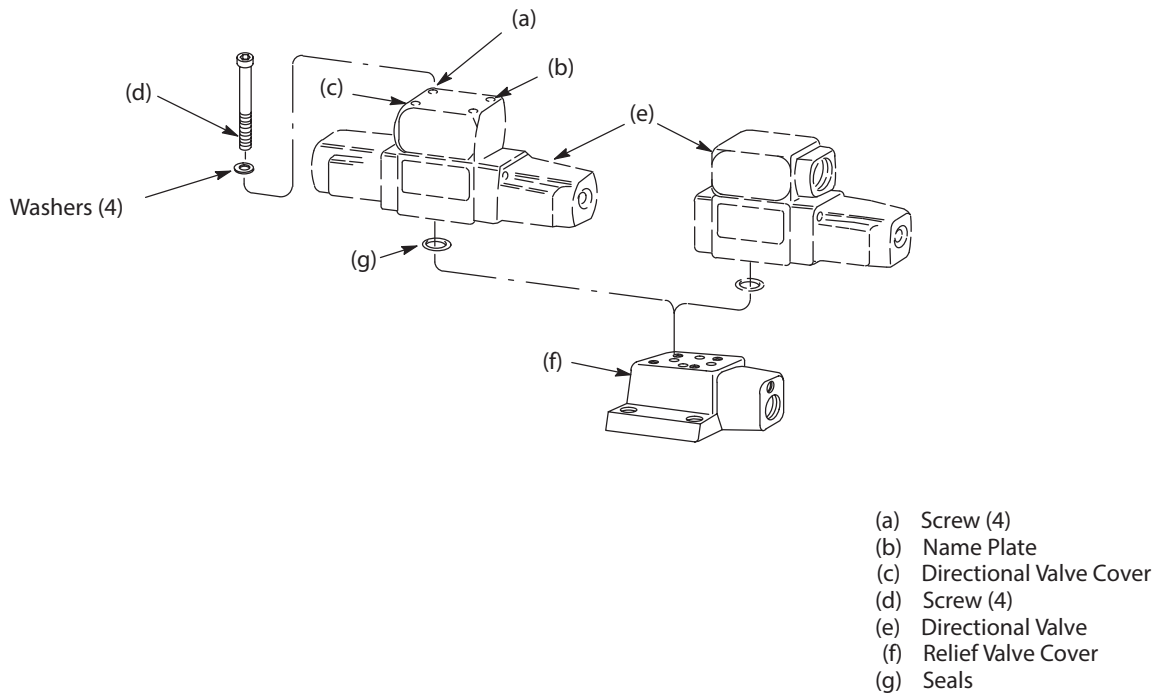

Figure 6. C*5 Solenoid Controlled Relief Valve

7. If seat (19) was removed during disassembly, make sure inside of body (21) is clean and free from damage.

8. Inspect mounting surfaces on cover and body for burrs, nicks, or scratches. Remove burrs and/or scratches with India stone or polishing paper. Also check body and cover for damaged or worn threads. If threads are worn or damaged, replace the part.

F. Assembly

Assembly of parts will be in reverse numerical sequence as shown in Figure 5. Obtain new seals. Seal kits are noted on the parts and service drawings that are tabulated in Section I, B. Make sure all parts are clean prior to assembly. Lubricate all parts with a light film of clean hydraulic fluid.

1. Secure body (21) in a vise.

2. If sleeve (20) was removed during disassembly, insert the sleeve into bottom of body bore.

NOTE

This step applies to C*-H**-30/50 models only.

3. If seat (19) was removed, install new seat into body (21) as follows:

a. Lubricate seat with petroleum jelly or grease that is compatible with system fluid.

b. Position the seat square over the body bore. Place a rod against the seat. Hold the rod centered. Tap on end of rod with hammer until seat is started into body, then drive the seat into the body bore until it bottoms out. Inspect the body and seat to be sure no chips or metal shavings were developed.

4. Install parts (18) through (15).

NOTE

Spring (16) is used on high vent models only ('V' in the model code).

5. Slide piston (18) back and forth within the body bore. Also rotate the piston 360 ° to make sure piston movement is free and without bind.

6. Assemble cover (14) to body (21). Cross tighten four screws (13) evenly. Torque the screws to 14.9-20.3 Nm. (133-178 lb. in.).

7. Secure valve body in vise to a horizontal position. Place screwdriver or similar tool in tank port against bottom of piston (18). Push the piston up and down within the body. If the piston hangs up or binds, loosen screws (13) on cover (14) to snug condition. Lightly tap around cover perimeter with a soft tip hammer until the piston moves freely within the body bore. Retighten the cover screws.

8. Install parts (11) through (9).

NOTE

Restriction plug (11) exists in C*-10-**- models only. Torque plug (9) to 22.6-27.1 Nm. (200-240 lb. in.).

9. Install parts (8) through (3). Be sure to install the same quantity of spacers (4) that were removed. The spacers determine the pressure adjustment range of the valve. Make sure seal (6) is assembled on plunger (5).

10. Install parts (2) and (1). Thread knob (1) in retainer (3) approximately five complete turns.

NOTE

The following step applies to C*5 solenoid operated relief valves only.

11. Assemble directional valve on cover in reverse alphabetical sequence as shown in Figure 6. Torque screws (d) to 5.6 Nm. maximum (50 lb. in.).

Section VII – Start-up and Test

A. Start-up

Start the system and sequence the unit through all positions while watching for appropriate movement of actuators. Improper or erratic movement of the actuators may indicate incorrect assembly of the unit or presence of trapped air.

B. Test

A test stand having regulated flow, temperature control and special fixtures is required to fully test the performance of the rebuilt unit. Because of this, only the functional test shown in the start-up paragraph is given. If such a test stand is available, test the unit to the requirements set forth in the installation drawings.

Products we offer:

- Cartridge valves
- DCV directional control valves
- Electric converters
- Electric machines
- Electric motors
- Gear motors
- Gear pumps
- Hydraulic integrated circuits (HICs)
- Hydrostatic motors
- Hydrostatic pumps
- Orbital motors
- PLUS+1® controllers
- PLUS+1® displays
- PLUS+1® joysticks and pedals
- PLUS+1® operator interfaces
- PLUS+1® sensors
- PLUS+1® software
- PLUS+1® software services, support and training
- Position controls and sensors
- PVG proportional valves
- Steering components and systems
- Telematics

Hydro-Gear

www.hydro-gear.com

Daikin-Sauer-Danfoss

www.daikin-sauer-danfoss.com

Danfoss Power Solutions is a global manufacturer and supplier of high-quality hydraulic and electric components. We specialize in providing state-of-the-art technology and solutions that excel in the harsh operating conditions of the mobile off-highway market as well as the marine sector. Building on our extensive applications expertise, we work closely with you to ensure exceptional performance for a broad range of applications. We help you and other customers around the world speed up system development, reduce costs and bring vehicles and vessels to market faster.

Danfoss Power Solutions – your strongest partner in mobile hydraulics and mobile electrification.

Go to www.danfoss.com for further product information.

We offer you expert worldwide support for ensuring the best possible solutions for outstanding performance. And with an extensive network of Global Service Partners, we also provide you with comprehensive global service for all of our components.

Local address:

**Danfoss
Power Solutions (US) Company**
2800 East 13th Street
Ames, IA 50010, USA
Phone: +1 515 239 6000

**Danfoss
Power Solutions GmbH & Co. OHG**
Krokamp 35
D-24539 Neumünster, Germany
Phone: +49 4321 871 0

**Danfoss
Power Solutions ApS**
Nordborgvej 81
DK-6430 Nordborg, Denmark
Phone: +45 7488 2222

**Danfoss
Power Solutions Trading
(Shanghai) Co., Ltd.**
Building #22, No. 1000 Jin Hai Rd
Jin Qiao, Pudong New District
Shanghai, China 201206
Phone: +86 21 2080 6201