



Power Plugs for Proportional Valves

EHH-AMP-702-D/J/K; 2* Series

For use with valve types:

- KDG4V-3(S)-H*-6*
- KTG4V-3(S)-H*-6*
- KDG4V-5-H*-3*
- KTG4V-5-H*-3*
- KCG-3/6/8-H1-1*
- KX(C)G-6/8-H1-1*
- KDG5V-5/7/8-H1-1*
- CMX***-E-G
- EPV**_-12D-1*
- ERV1/2**_-12D-1*
- EPFR1**_-12D-1*

General Description

Three types of plugs, conforming to ISO 4400/DIN 43650 interface, with integral amplifiers and necessary adjustment potentiometers, are designed for use with non-feedback hydraulic valves.

This plug/valve combination offers very low cost solutions to many hydraulic control problems requiring proportional control.

Type D is controlled with a 0-10V command signal, and has adjustable gain, ramp, deadband compensation and dither.

Type J, designed for closed-loop applications, is controlled with a 0-10V command signal, and has no ramp function.

Type K is controlled with a 4-20 mA command signal, and has an adjustable ramp time of 50 ms to 5s.

Features and Benefits

- Integral amplifier provides essential functions for control of proportional valves
- Adjustable ramp time (types D and K), gain, deadband compensation and dither
- Ease of installation, with reduced cost
- Fully short-circuit and reverse-polarity protected
- Differential voltage command signal (types D and J)

- Adjustable dither
- EMC to latest European standards
- Protection to IP67

Application

Primary applications are in the control of directly operated, non-feedback proportional valves where the cost of more sophisticated electronic controls can be avoided.

Type J is for closed-loop applications.

Electrical Block Diagram

EHH-AMP-702-D/J/K-2*

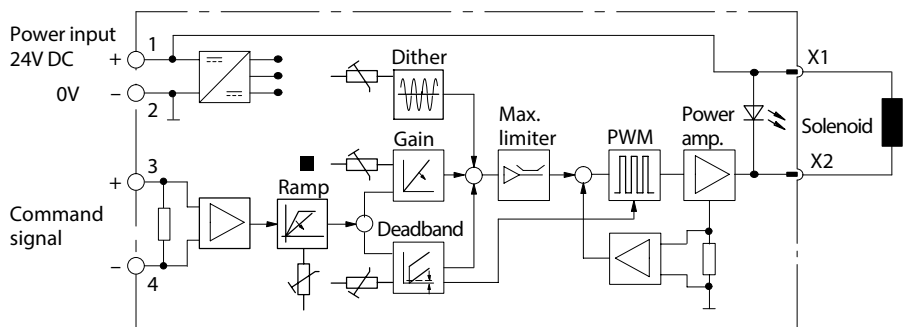

■ Type J does not have the ramp function.

Model Code

EHH-AMP-702- * - 2*

1 2

- 1 Adjustment range
- D = Proportional plug: 50 ms to 5s
 - J = Proportional plug without ramp function
 - K = Proportional plug: 4-20 mA

- 2 Design number, 20 series
- Subject to change. Installation dimensions unaltered for design numbers 20 to 29 inclusive.



This product has been designed and tested to meet specific standards outlined in the European Electromagnetic Compatibility Directive (EMC) 89/336/EEC, amended by 91/263/EEC, 92/31/EEC and 93/68/EEC, article 5. For instructions on installation requirements to achieve effective protection levels, see this leaflet and the Installation Wiring Practices for Vickers by Danfoss Electronic Products leaflet 2468. Wiring practices relevant to this Directive are indicated by Electromagnetic Compatibility (EMC).

Operating Data

Electrical		
	Types D and J	Type K
Connections		
1	24V DC	
2	0V (power and signal)	
3	Positive command signal	
4	Negative command signal	
Power (input) supply	20-30V DC including $\pm 10\%$ maximum ripple (peak-to-peak) 24V DC nominal	
Absolute maximum voltage	40V	
Max. power consumption incl. solenoid	35W	
Reverse polarity protected	Yes	
Short circuit protected	Yes	
Maximum output current	1,6A	
Max. output voltage typical (1,6A output current)	Typically 1,5V below supply voltage	
Command signal	0-10V (10 kohms)	4-20 mA (250 ohms)
Deadband triggering	200 mV	4 mA
For output (LED ON)	200 mV to 10V	4-20 mA
For no output (LED OFF)	0 mV to 100 mV	0-4 mA
Deadband adjustment range	100 to 1000 mA	
Gain adjustment range	0.02 A/V to 0.16 A/V	0.01 A/mA to 0.08 A/mA
Dither adjustment range	0 to 500 mA	
Ramp time (types D and K only)	50 ms to 5s	
PWM frequency	1200 Hz $\pm 10\%$	
Dither frequency	120 Hz $\pm 10\%$	
Protection	IEC 529: IP67 (when correctly installed with interface seal in place) Fully short-circuit and reverse-polarity protected	
Isolation to VDE 0110	Group "B"	
Electromagnetic compatibility (EMC):		
Emission	EN 50081-2	
Immunity	EN 50082-2	
Mechanical		
Housing	PA6 glass-reinforced plastic (conforming to UL-94HB). Color: gray	
Mounting interface	ISO 4400 (DIN 43650)	
Cable clamp	Pg9 screw type	
Cable diameter	\varnothing 5 to 10 mm (0.197 to 0.394 " dia)	
Wire section	0,5 to 1,0 mm ² (20 AWG-17 AWG)	
Temperature, ambient range	-20° to +70 °C (-4° to +158 °F)	
Mass	0,07 kg (0.154 lb)	

Input/Output Characteristics
Types D and K

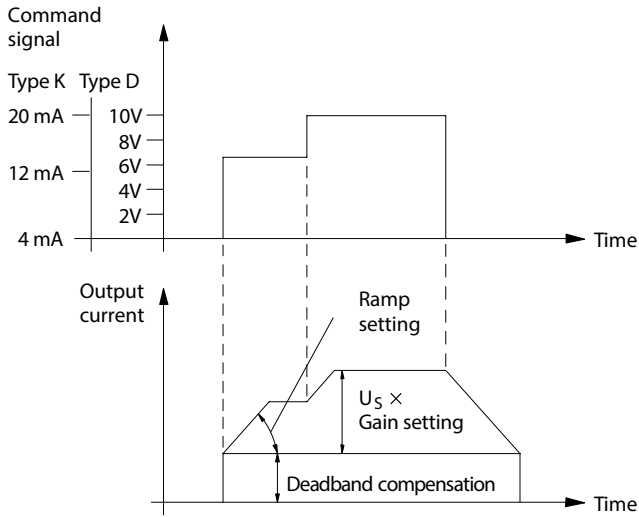

Type J

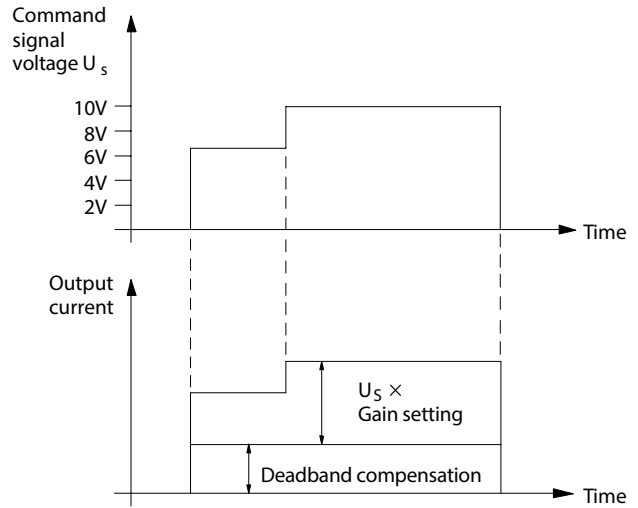

Installation Dimensions in mm (inches)

3rd angle projection

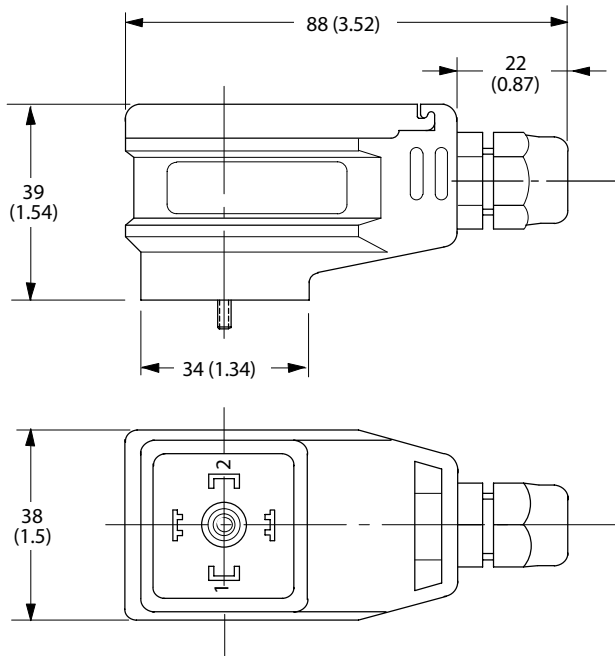
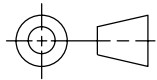

Solenoid Connections

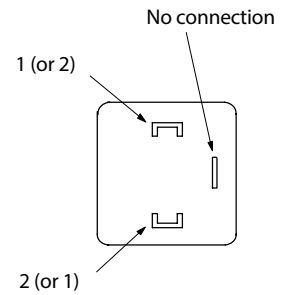

Installation Data

Adjustments

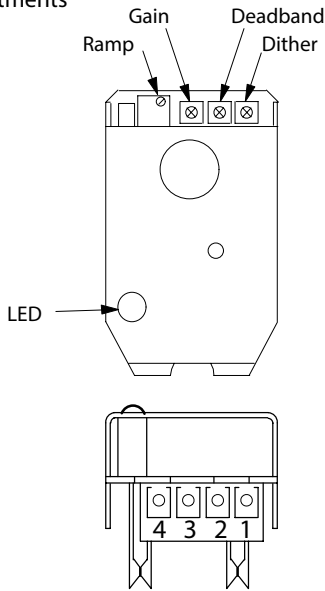

Ramp time:
Turn clockwise to increase ramp time.
(Only types D/K)

Gain:
Turn clockwise to increase gain.

Deadband compensation:
Turn clockwise to increase deadband compensation current.

Dither:
Turn clockwise to increase the dither current.

Terminal 1:
Power supply 20V-30V DC, positive.

Terminal 2:
Power supply 0V.

Terminal 3:
Command signal positive (see "Operating Data").

Terminal 4:
Command signal negative (see "Operating Data").

Installation Wiring Options

Positive Command Voltage

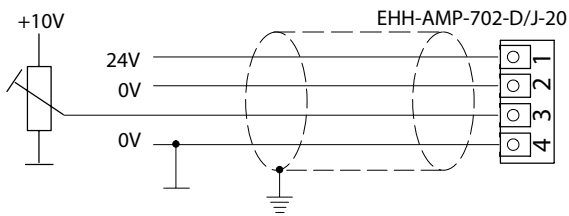

Negative Command Voltage

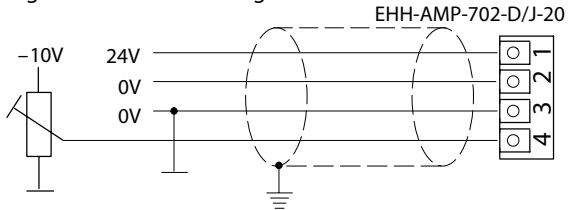

4-20 mA Command Signal

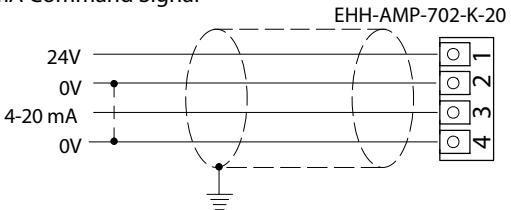

Bi-polar Command Voltage for Operating Two Solenoids from One Signal

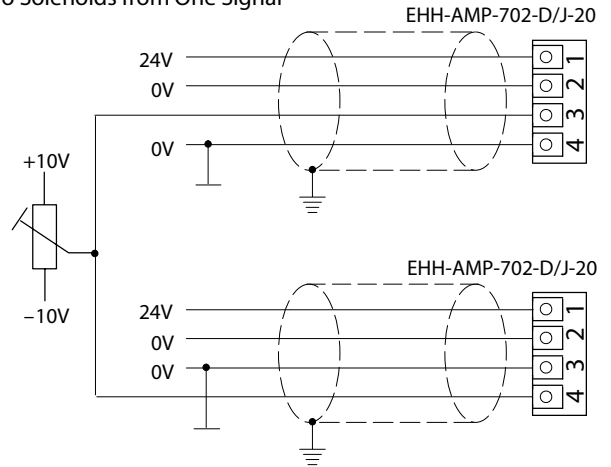

Connections when replacing -10 design power plug with -20 design and only 3 wires exist

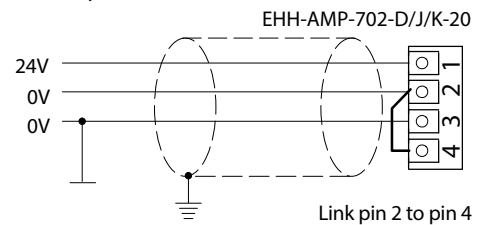

Customer's protective ground connection.



Warning: Electromagnetic Compatibility (EMC)
Screened cables should be used and particular attention paid to the grounding of the screens as shown in the above diagrams.

Installation Data

Assembly Showing Wiring Connection Points

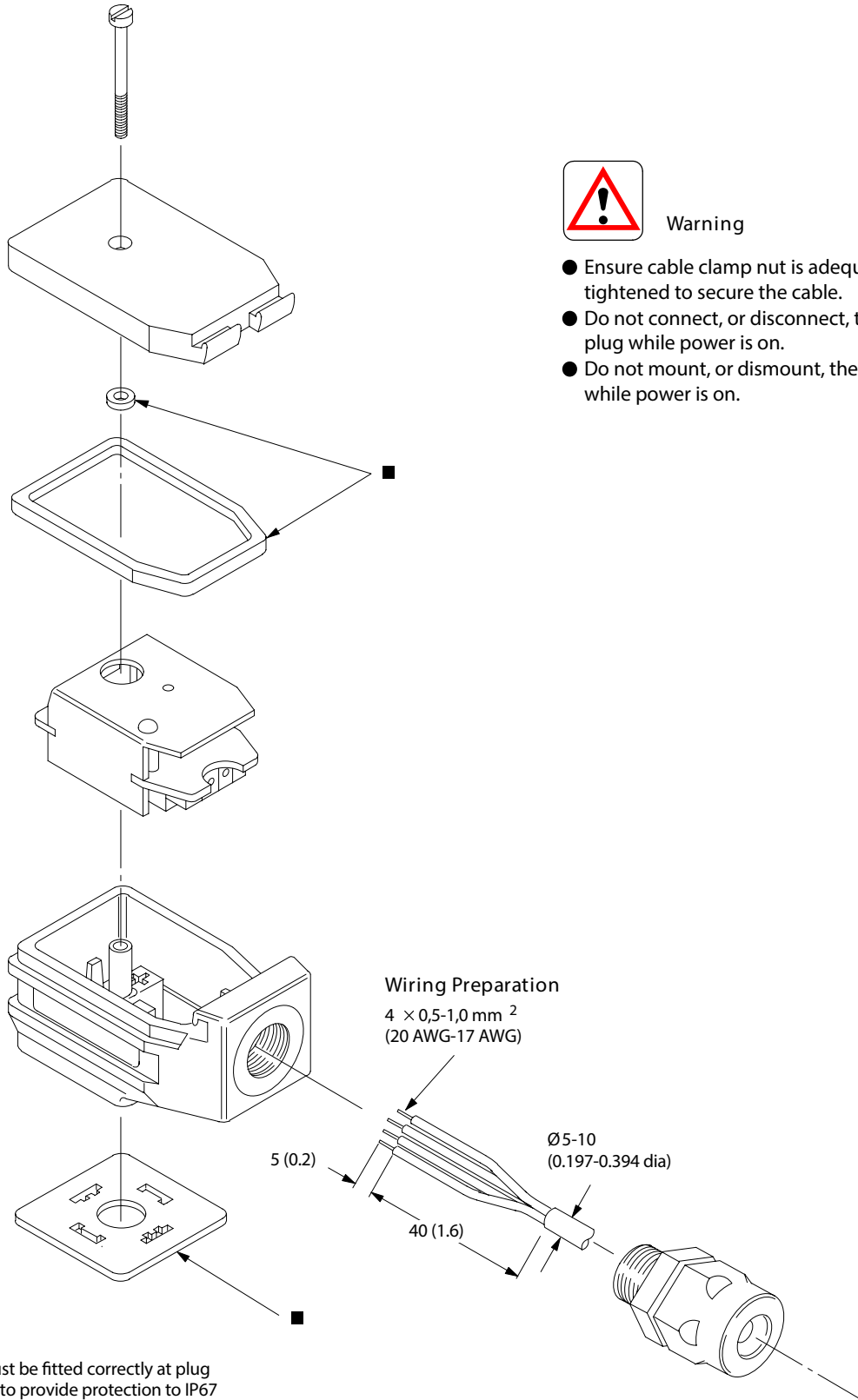

Start-Up Procedure

- Correctly wire the plug and, before mounting it on the valve solenoid, apply 24V DC (20 to 30V limits) to the “power input” terminals.
- Check for correct plug function by illumination/non-illumination of the LED. The LED should illuminate when the demand applied to the “signal input” terminal is between 200 mV and 10V (or 4 mA and 20 mA) and should not be illuminated when the applied demand is less than 100 mV (4 mA). If there is a malfunction a new plug must be fitted.
- Switch off power supply and command/input signal and then install plug on solenoid. Ensure that all seals are fitted correctly and clamped as the retaining screw is tightened: this is essential in providing IP67 protection.
- Ensure that the hydraulic system will not cause any erratic movement of actuators, then:
 - Switch on power supply again.
 - Repeat LED/function check as in 2.An LED malfunction now indicates a short circuit at the load.
- Successful completion of these checks means that the plug and load are ready for use.

Spare Parts

The only spare part available is the interface seal, part number 732100.

Ordering Procedure

Order plug by full model code, and spare interface seals by part number 732100.

Products we offer:

- Cartridge valves
- DCV directional control valves
- Electric converters
- Electric machines
- Electric motors
- Gear motors
- Gear pumps
- Hydraulic integrated circuits (HICs)
- Hydrostatic motors
- Hydrostatic pumps
- Orbital motors
- PLUS+1® controllers
- PLUS+1® displays
- PLUS+1® joysticks and pedals
- PLUS+1® operator interfaces
- PLUS+1® sensors
- PLUS+1® software
- PLUS+1® software services, support and training
- Position controls and sensors
- PVG proportional valves
- Steering components and systems
- Telematics

Danfoss Power Solutions is a global manufacturer and supplier of high-quality hydraulic and electric components. We specialize in providing state-of-the-art technology and solutions that excel in the harsh operating conditions of the mobile off-highway market as well as the marine sector. Building on our extensive applications expertise, we work closely with you to ensure exceptional performance for a broad range of applications. We help you and other customers around the world speed up system development, reduce costs and bring vehicles and vessels to market faster.

Danfoss Power Solutions – your strongest partner in mobile hydraulics and mobile electrification.

Go to www.danfoss.com for further product information.

We offer you expert worldwide support for ensuring the best possible solutions for outstanding performance. And with an extensive network of Global Service Partners, we also provide you with comprehensive global service for all of our components.

Local address:

Hydro-Gear

www.hydro-gear.com

Daikin-Sauer-Danfoss

www.daikin-sauer-danfoss.com

**Danfoss
Power Solutions (US) Company**
2800 East 13th Street
Ames, IA 50010, USA
Phone: +1 515 239 6000

**Danfoss
Power Solutions GmbH & Co. OHG**
Krokamp 35
D-24539 Neumünster, Germany
Phone: +49 4321 871 0

**Danfoss
Power Solutions ApS**
Nordborgvej 81
DK-6430 Nordborg, Denmark
Phone: +45 7488 2222

**Danfoss
Power Solutions Trading
(Shanghai) Co., Ltd.**
Building #22, No. 1000 Jin Hai Rd
Jin Qiao, Pudong New District
Shanghai, China 201206
Phone: +86 21 2080 6201

Danfoss can accept no responsibility for possible errors in catalogues, brochures and other printed material. Danfoss reserves the right to alter its products without notice. This also applies to products already on order provided that such alterations can be made without subsequent changes being necessary in specifications already agreed. All trademarks in this material are property of the respective companies. Danfoss and the Danfoss logotype are trademarks of Danfoss A/S. All rights reserved.