

Product Specification

Auto Water Shut Off Kit

Avoid costly water bills caused by leaking outlets from faulty, damaged or tampered taps and WCs with the Watersavers Auto Water Shut Off Kit.

The Auto Water Shut Off Kit works by only allowing water to flow to the washroom when occupants are detected, so any leaks and drips are limited to just when washroom users are present - greatly minimising water wastage.

A low-profile, recessed ceiling infra-red detector, in conjunction with a Danfoss solenoid valve control the flow of water supply to the washroom.



Product Code

| | |
|------|--------|
| 1/2" | AWS-15 |
| 3/4" | AWS-22 |
| 1" | AWS-28 |

Features

- Use to turn off water and energy when area is unoccupied
- Minimises water wastage from leaking, faulty or damaged outlets that have been subject to wear or vandalism
- Save up to 75% on water & energy costs
- Fulfils requirement 3d of the BREEAM Wat 03
- Standard 230 VAC power
- Several PIR switches spaced 5 m apart may be connected in parallel to extend area of coverage
- 12-month warranty
- Manufactured in the UK

PIR Specification

- For flush mounting in plasterboard or suspended ceiling
- 360° detection zone
- Loading: 6 amp maximum (any load)
- Time delay 10 seconds to 40 minutes
- Photocell range: 100-1000 lux and inactive
- Dimensions: 72 mm diameter x 68 mm depth
- Requires 63-64 mm (2.5") hole in ceiling & 68 mm void height

Solenoid Shut Off Valve Features

- WRAS approved with EPDM sealing; 0 - 90 °C
- Standard equipped with clip on coil for dry and humid environments
- Enclosure: IP65 rated

PIR Technical Specification

| | |
|-----------------|--|
| Detection area | 360° |
| Time lag range | 10 seconds to 40 minutes (nine steps) |
| Photocell range | 100-1000 lux and inactive |
| Loading | Up to 6 amp (1500 W) of resistant, fluorescent in inductive lighting loads, or up to 1 amp (250 W) of fans |
| Dimensions | 72 mm diameter x 68 mm |

Ceiling Mounted PIR Occupancy Switch

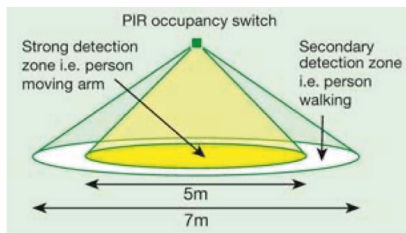

Recommended mounting height between 2.2 m and 5 m.

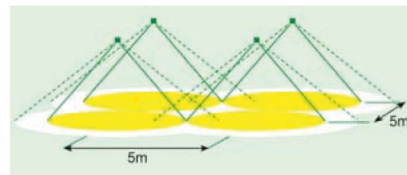

In open plan areas. For best coverage the PIR occupancy switches should be spaced every 5 m in either direction.

Wiring Diagrams Single and Multiple

Single Ceiling Mounted PIR Occupancy Switch

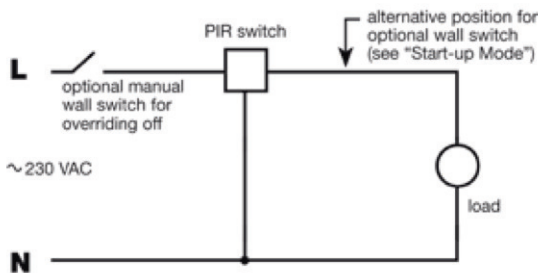

Multiple Ceiling Mounted PIR Occupancy Switches in parallel

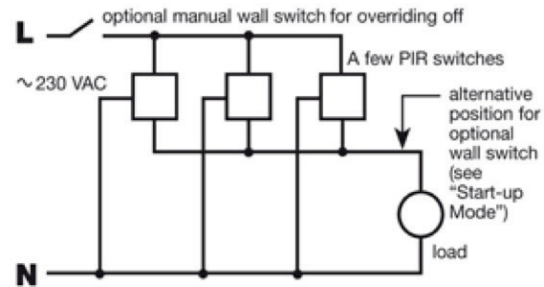

Fitting Requirements

Requires 63 or 64 mm (2.5") diameter hole in a false or plasterboard ceiling.

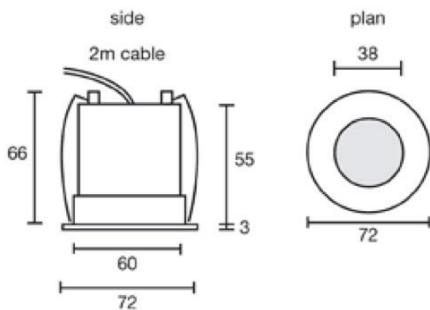

Start-up

When the mains supply is connected to the PIR occupancy switch it will initiate a start-up sequence. This means it switches on for approximately one minute, switches off and activates the operating mode. If a manual wall switch is feeding the switch (see wiring diagrams) it will initiate the start-up sequence each time the wall switch is switched on. By wiring the manual wall switch in the alternative position, the supply to the switch is uninterrupted and it remains in operating mode.

Solenoid Shut Off Valve Technical Specification

General

Compact indirect servo-operated 2/2 way solenoid valves, especially designed for use within a limited space.

Overview

| | |
|-----------------------------------|-------------|
| Body material | Brass |
| DN [mm] | 10-50 |
| Connection | G3/8" - G2" |
| Sealing material | EPDM, NBR |
| K_v [m ³ /h] | 1.6-32 |
| Differential pressure range [bar] | 0.2-10 |
| Temperature range [°C] | -30-100 |

Materials in Contact with Fluid

| | |
|--|-----------------|
| Valve body/cover | Brass |
| Armature/armature stop, Armature tube and Springs | Stainless steel |
| O-ring, Valve plate and Diaphragm | EPDM |

Notes:

Sealings: EPDM = Ethylene-propylene elastomer (WRAS/KTW certified compound)

- Operation with gaseous media, at high pressure without any outlet restriction, can reduce the diaphragm life.

Coil

Standard Coil supplied - 230V, 50/60Hz, 8W

Coils available in various voltages and specifications, please enquire for full details of range and product offerings.

Function

Coil voltage disconnected (valve closed)

When voltage is disconnected, the armature spring (2) presses the armature (3) down against the pilot orifice (4). Pressure builds up over the diaphragm (5) via the equalizing orifice (6). The diaphragm closes the main orifice (7) as soon as the pressure over the diaphragm equals the inlet pressure. The valve stays closed for as long as voltage remains disconnected.

Coil voltage connected (valve open)

When voltage is applied to the coil (1), the pilot orifice (4) is opened. Since the pilot orifice is larger than the equalizing orifice (6), pressure over the diaphragm (5) falls and the diaphragm is lifted clear of the main orifice (7). The valve stays open for as long as the required minimum differential pressure is present and voltage is applied to the coil.

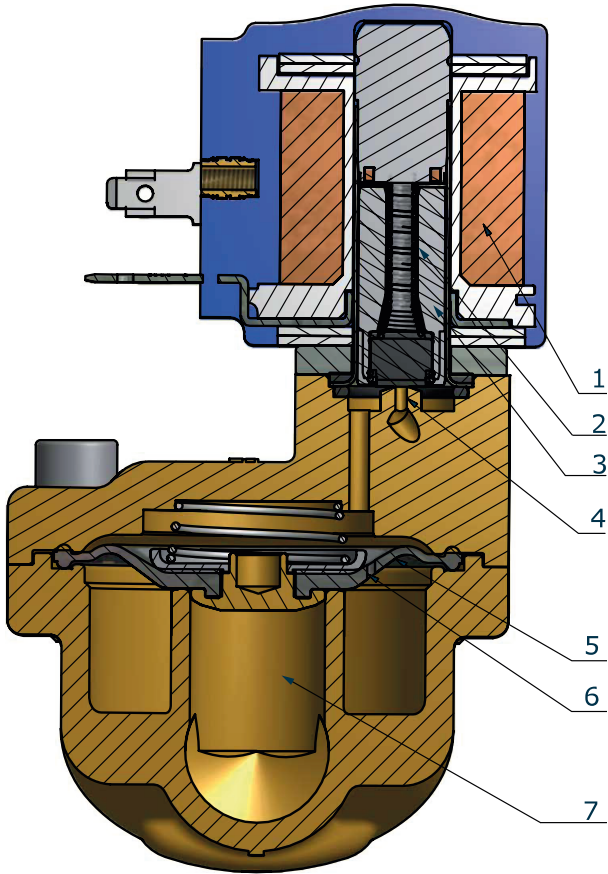

| | |
|---|--------------------|
| 1 | Coil |
| 2 | Armature spring |
| 3 | Armature |
| 4 | Pilot orifice |
| 5 | Diaphragm |
| 6 | Equalising orifice |
| 7 | Main orifice |

Applications

It is recommended to use a filter in front of the valve. Recommended filter 50 mesh (297 microns).

In water applications, exercise the valves at least once every 24 hours, meaning change the state of the valve. The valve exercise will minimise the risk of the valve sticking due to calcium carbonate, zinc or iron oxide build-up.

To minimise scaling, and corrosion attack it is recommended that the water passing the valve have the following values:

- Hardness 6-18 °dH to avoid scaling (chalk / lime stone build up).
- Conductivity 50 – 800 µS/cm to avoid brass dezincification and corrosion.
- Above 25°C media temperature avoid stagnant water inside the valve to avoid dezincification and corrosion attack.

Product Specification

Coil voltage disconnected (valve closed)

When voltage is disconnected, the armature spring (2) presses the armature (3) down against the pilot orifice (4). Pressure builds up over the diaphragm (5) via the equalizing orifice (6). The diaphragm closes the main orifice (7) as soon as the pressure over the diaphragm equals the inlet pressure. The valve stays closed for as long as voltage remains disconnected.

Coil voltage connected (valve open)

When voltage is applied to the coil (1), the pilot orifice (4) is opened. Since the pilot orifice is larger than the equalizing orifice (6), pressure over the diaphragm (5) falls and the diaphragm is lifted clear of the main orifice (7). The valve stays open for as long as the required minimum differential pressure is present and voltage is applied to the coil.

| | | |
|--|-----------------------|---|
| Media | EPDM | For water and drinking water (WRAS approvals) |
| Media temperature [°C] | EPDM NC WRAS approved | 0 - 90 °C |
| Ambient temperature [°C] | -40-50 °C | |
| K _v value [m ³ /h] | ½" AWS-15 | 4 m ³ /h |
| | ¾" AWS-22 | 7 m ³ /h |
| | 1" AWS-28 | 7 m ³ /h |
| Min. Opening differential pressure [bar] | 0.3 bar | |
| Max. Opening differential pressure [bar] | 10 bar | |
| Max. working pressure [bar] | 10 bar | |
| Max. test pressure [bar] | 15 bar | |
| Viscosity [cSt] | Max. 50 cSt | |