

Installation guide – Spare parts and accessories

Inspection kit | Code number 148B6053

SVA-S/L, SVA-ST/LT, REG-SA/SB, REG, SVA-HS, SCA/X, FIA, CHV/X size 50

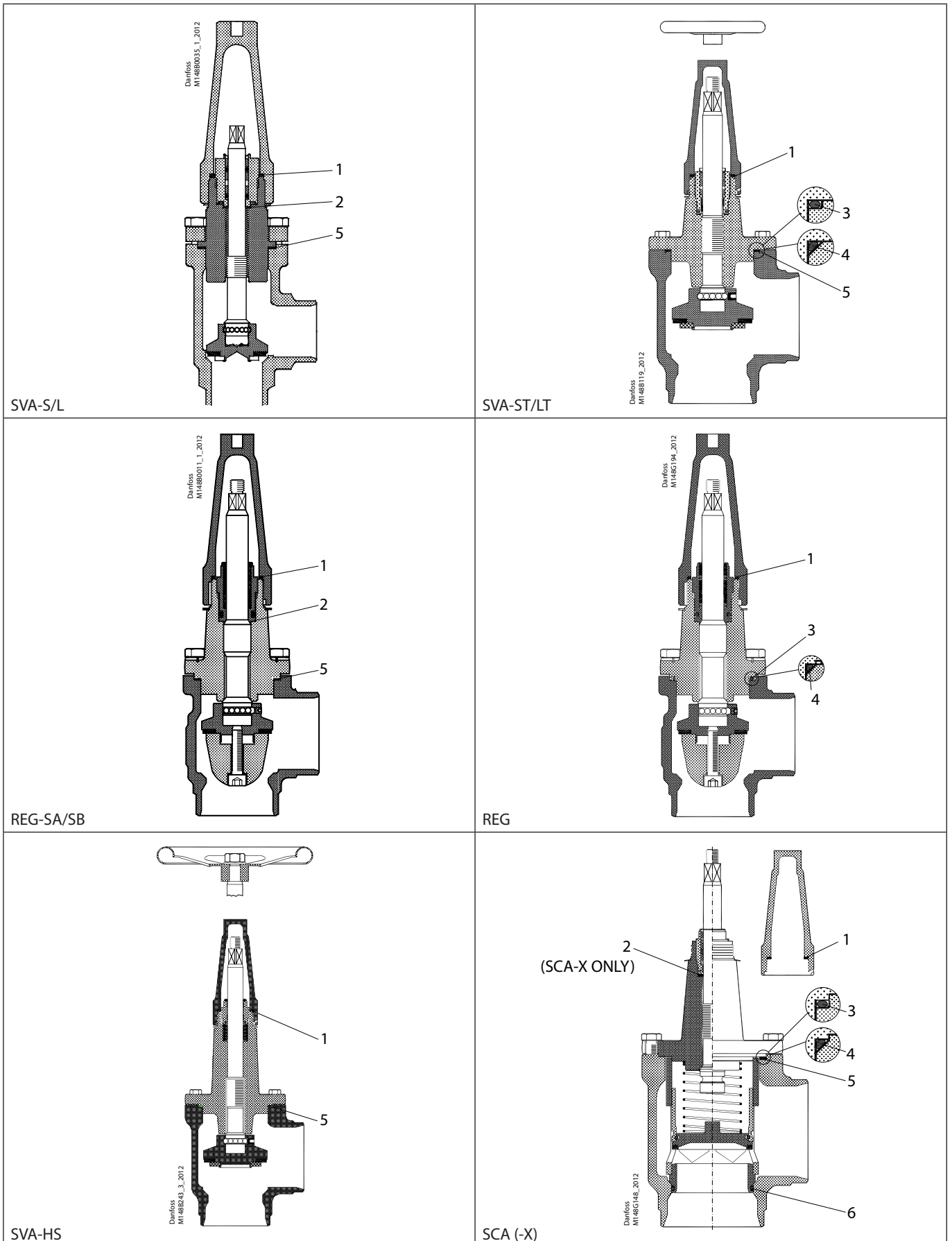

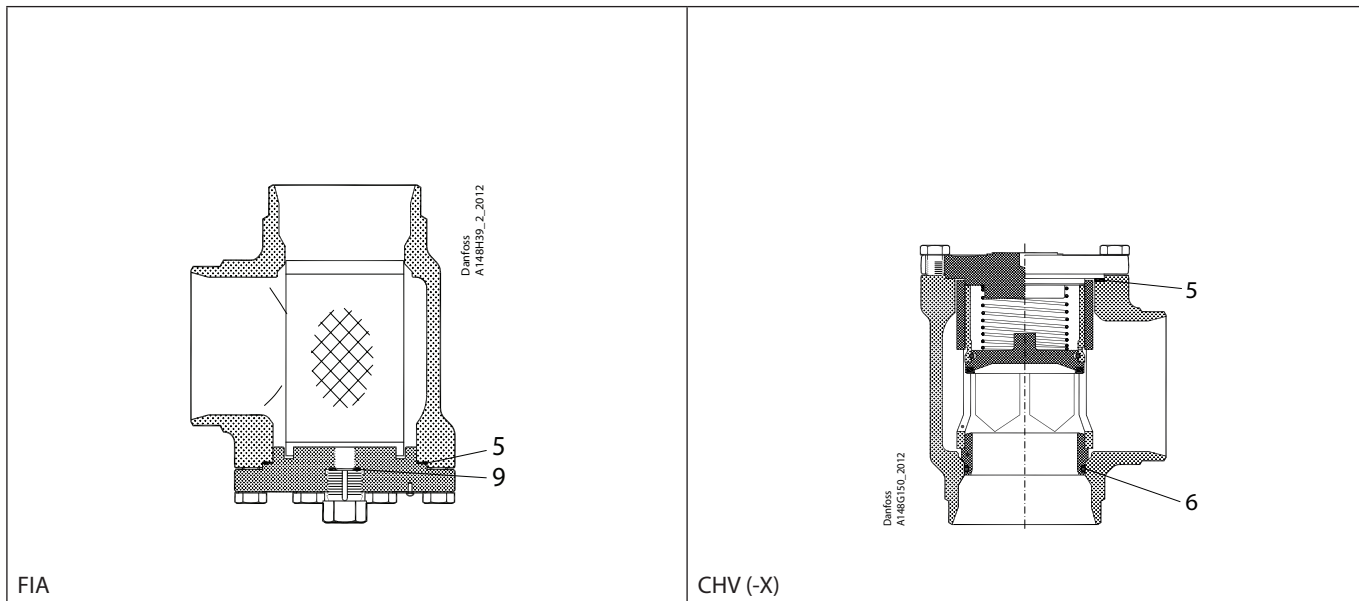

<p>1</p> <p> = Nylon</p> <p>Ø37 mm Ø1.46"</p> <p>Total no. = 1</p>	<p>2</p> <p> = Alu.</p> <p>Ø26.5 mm Ø1.04"</p> <p>Total no. = 1</p>	<p>3</p> <p>Ø50 mm Ø1.97"</p> <p>Total no. = 1</p>	<p>4</p> <p>Ø47 mm Ø1.85"</p> <p>Total no. = 1</p>	<p>5</p> <p> = Fibre</p> <p>Ø63.5 mm Ø2.5"</p> <p>Total no. = 1</p>
<p>6</p> <p>Ø41 mm Ø1.61"</p> <p>Total no. = 1</p>	<p>9</p> <p> = Alu.</p> <p>Ø18 mm Ø0.71"</p> <p>Total no. = 1</p>			