

Installation guide – Spare parts and accessories

Repair kit | Code number 148B6061

SVA-S/L, SVA-ST/LT, REG-SA/SB, REG, SVA-HS, SCA/X sizes 15 - 20

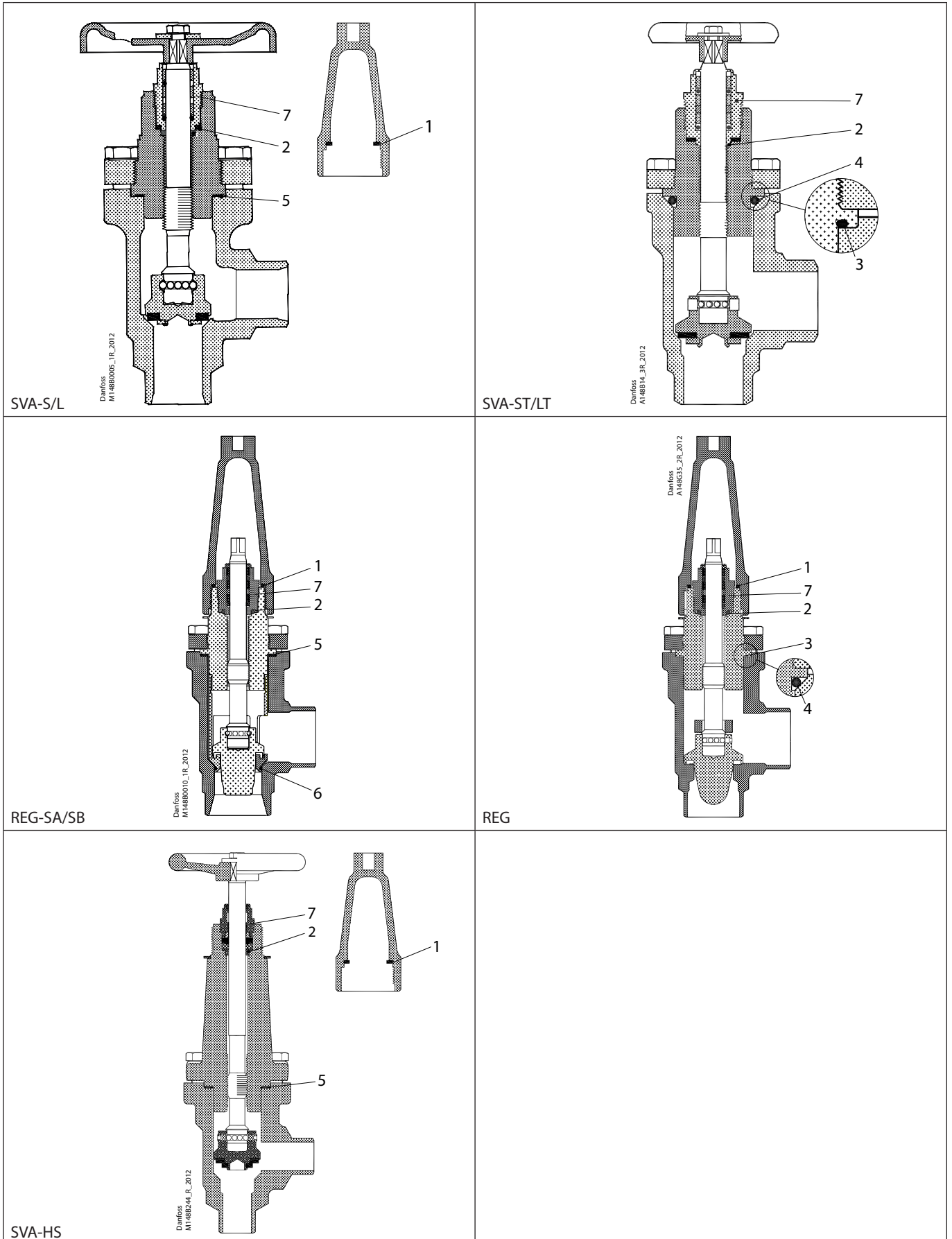

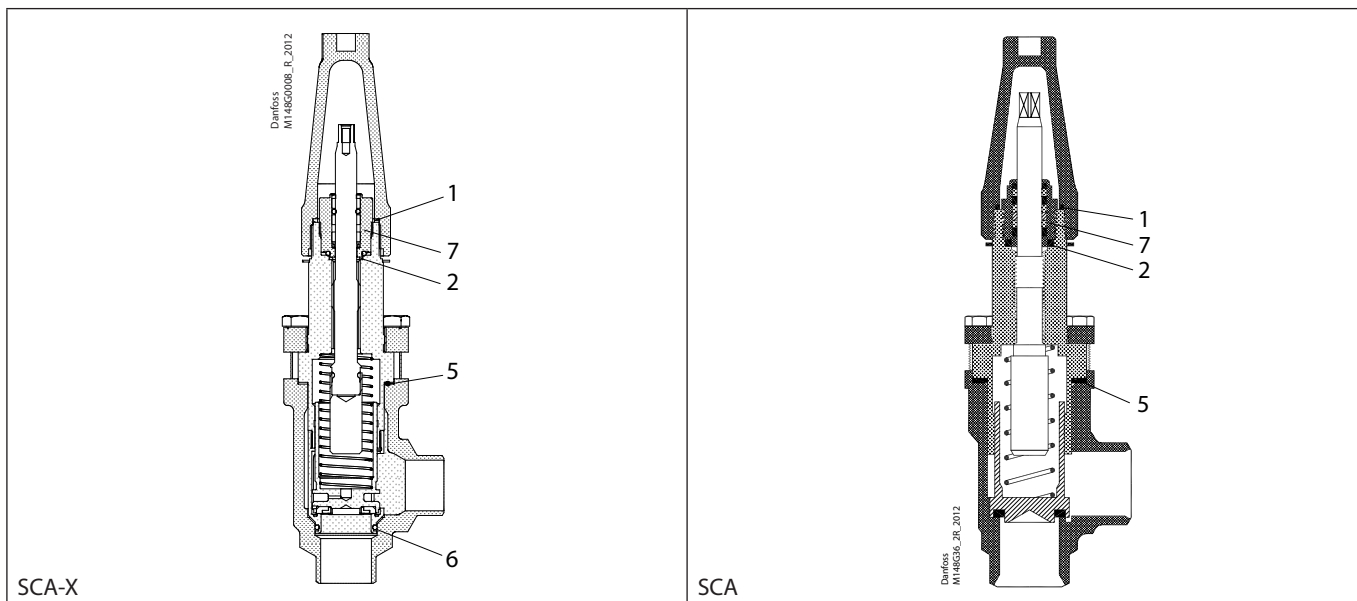

<p>1</p> <p> = Nylon</p> <p>Total no. = 1</p>	<p>2</p> <p> = Alu.</p> <p>Total no. = 1</p>	<p>3</p> <p>Total no. = 1</p>	<p>4</p> <p>Total no. = 1</p>	<p>5</p> <p> = Fibre</p> <p>Total no. = 1</p>
<p>6</p> <p>Total no. = 1</p>	<p>7</p> <p>Total no. = 1</p>			

NOTE:

When replacing the packing gland (pos. 7) in SVA-ST, SVA-S/L, SVA-HS, REG-SA/SB, REG, SCA or SCA-X the aluminium gasket (pos. 2) is needed.