

Installation guide – Spare parts and accessories

Repair kit | Code number 148B6063

SVA-S/L, SVA-ST/LT, REG-SA/SB, REG, SVA-HS, SCA/X size 50

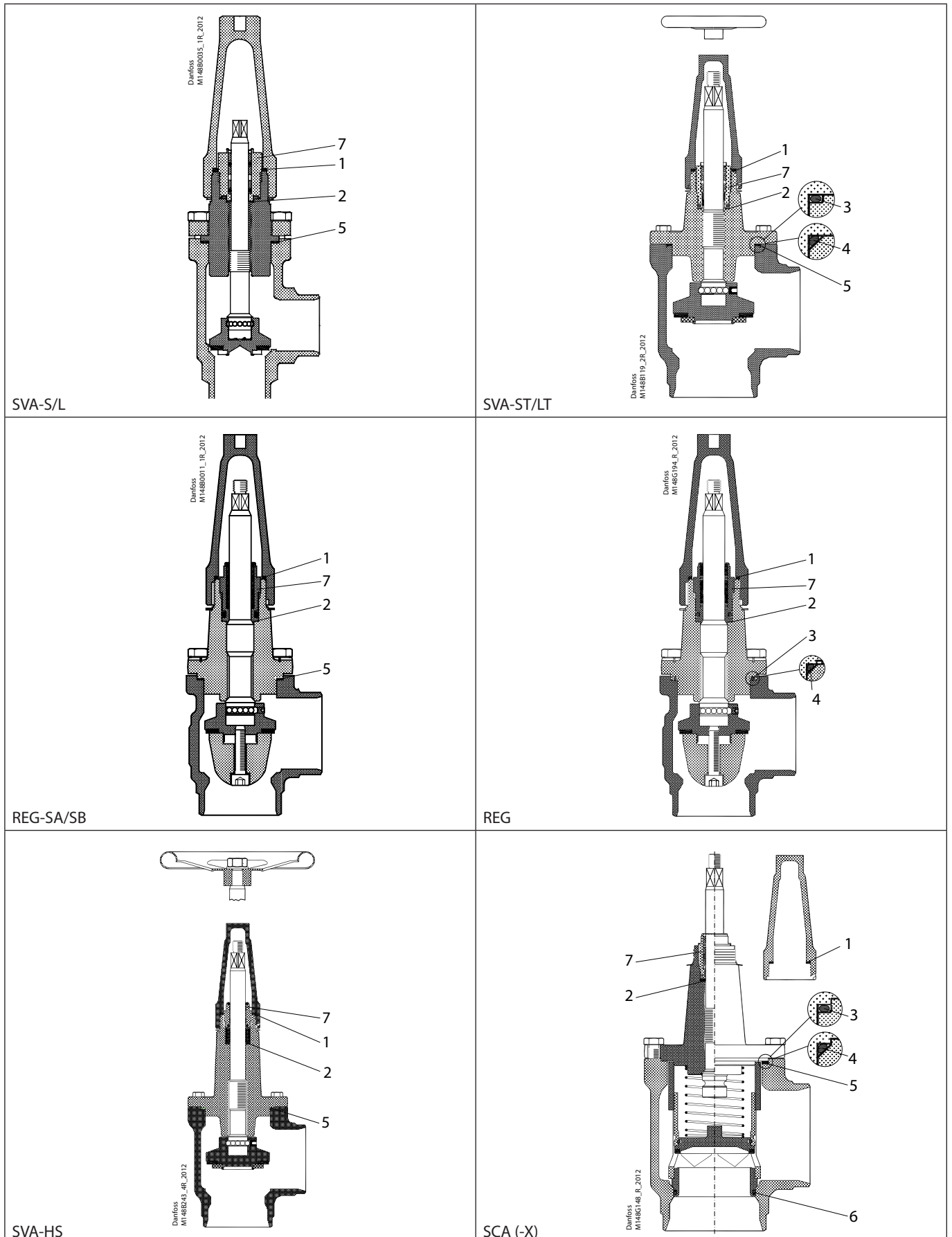

<p><b>1</b></p> <p> = Nylon</p> <p>Ø37 mm Ø1.46"</p> <p>Total no. = 1</p>	<p><b>2</b></p> <p> = Alu.</p> <p>Ø37 mm Ø1.46"</p> <p>Total no. = 1</p>	<p><b>3</b></p> <p>Ø50 mm Ø1.97"</p> <p>Total no. = 1</p>	<p><b>4</b></p> <p>Ø47 mm Ø1.85"</p> <p>Total no. = 1</p>	<p><b>5</b></p> <p> = Fibre</p> <p>Ø63.5 mm Ø2.5"</p> <p>Total no. = 1</p>
<p><b>6</b></p> <p>Ø41 mm Ø1.61"</p> <p>Total no. = 1</p>	<p><b>7</b></p> <p>Ø27 mm Ø1.06"</p> <p>Total no. = 1</p>			

**NOTE:**

When replacing the packing gland (pos. 7) in SVA-ST, SVA-S/L, SVA-HS, REG-SA/B, REG, SCA-X and SCA the aluminium gasket (pos. 2) is needed.