

INSTRUCTIONS LLZ COMPRESSORS

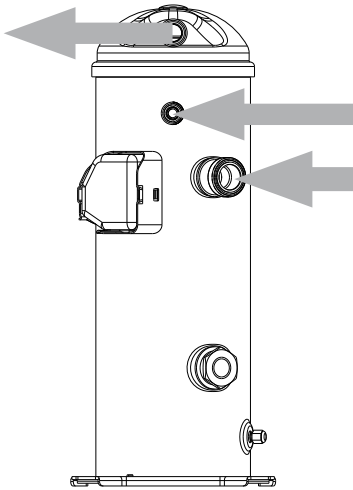

- A: Model number
- B: Serial Number
- C: Technical number
- D: Manufacturing year
- E: Internal protection
- F: Supply voltage range
- G: Locked rotor current
- H: Lubricant type and nominal charge
- I: Approved Refrigerant

⚠ Installation and servicing of the compressor by qualified personnel only. Follow these instructions and sound refrigeration engineering practice relating to installation, commissioning, maintenance and service.

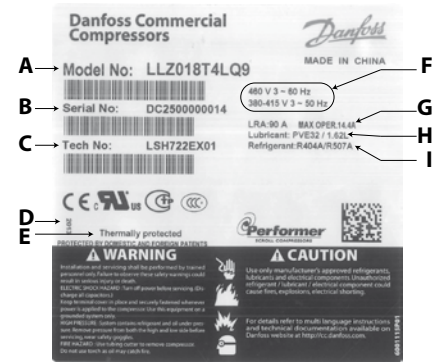

Operating limits

LLZ - R404A / R507 - Standard

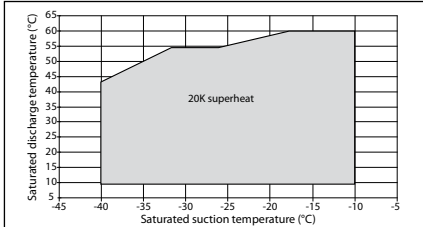

LLZ - R404A / R507 - Economizer cycle

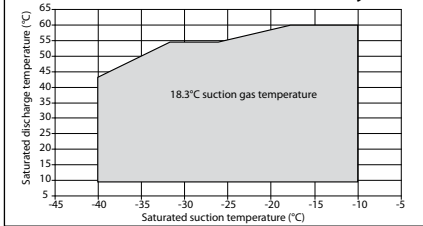

Electrical connections

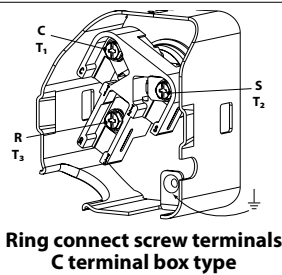

Ring connect screw terminals
C terminal box type

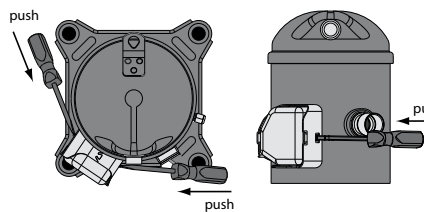

Three phase (Wiring diagram with pump-down cycle)

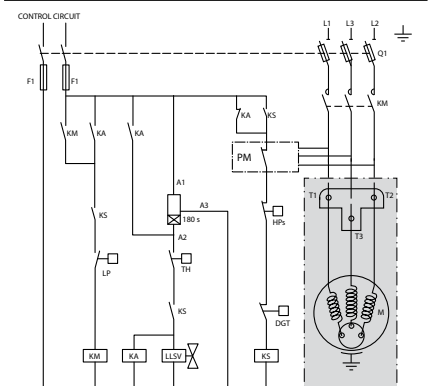

Wiring diagram with pump-down cycle

⚠ The compressor must only be used for its designed purpose(s) and within its scope of application (refer to «operating limits»). Consult Application guidelines and datasheet available from cc.danfoss.com

⚠ Never operate compressor without terminal box cover in place and secured.

The compressor is delivered under nitrogen gas pressure (between 0.3 and 0.4 bar / 4 and 6 psi). Do not disassemble bolts, plugs, fittings, etc... unless all pressure has been relieved from the compressor.

⚠ Under all circumstances, the EN378 (or other applicable local safety regulation) requirements must be fulfilled. Wear protective goggles and work gloves.

The compressor must be handled with caution in the vertical position (maximum offset from the vertical : 15°).

1 – Introduction

These instructions pertain to the LLZ scroll compressors used for refrigeration systems. They provide necessary information regarding safety and proper usage of this product.

2 – Handling and storage

- Handle the compressor with care. Use the dedicated handles in the packaging. Use the compressor lifting lug and use appropriate and safe lifting equipment.
- Store and transport the compressor in an upright position.
- Store the compressor between -35°C and 70°C / -31°F and 158°F.
- Don't expose the compressor and the packaging to rain or corrosive atmosphere.

3 – Safety measures before assembly

⚠ Never use the compressor in a flammable atmosphere.

- Mount the compressor on a horizontal flat surface with less than 7° slope.
- Verify that the power supply corresponds to the compressor motor characteristics (see nameplate).
- When installing a compressor for R404A, R507 or R407A, use equipment specifically reserved for HFC refrigerants which was never used for CFC or HCFC refrigerants.
- Use clean and dehydrated refrigeration-grade copper tubes and silver alloy brazing material.
- Use clean and dehydrated system components.
- The piping connected to the compressor must be flexible in 3 dimensions to dampen vibrations.
- The compressor must always be mounted

with the rubber grommets supplied with the compressor.

4 – Assembly

- Slowly release the nitrogen holding charge through discharge and suction ports.
- Connect the compressor to the system as soon as possible to avoid oil contamination from ambient moisture.
- Avoid material entering into the system while cutting tubes. Never drill holes where burrs cannot be removed.
- Do not exceed the maximum tightening torque for rotolock connections

Rotolock connections	Tightening torque
1" Rotolock	80 Nm
1" 1/4 Rotolock	90 Nm
1" 3/4 Rotolock	110 Nm

Instructions

- Connect the required safety and control devices. When the schrader port, if any, is used for this, remove the internal valve.
- For parallel assemblies of the compressors in version C8, contact Danfoss.

5 – Leak detection

⚠ Never pressurize the circuit with oxygen or dry air. This could cause fire or explosion.

- Do not use leak detection dye.
- Perform a leak detection test on the complete system.
- The low side test pressure must not exceed 31 bar / 450 psi.
- When a leak is discovered, repair the leak and repeat the leak detection.

6 – Vacuum dehydration

- Never use the compressor to evacuate the system.
- Connect a vacuum pump to both the LP & HP sides.
- Pull down the system under a vacuum of 500 μ m Hg (0.67 mbar) / 0.02 inch Hg absolute.
- Do not use a megohmmeter nor apply power to the compressor while it is under vacuum as this may cause internal damage.

7 – Electrical connections

- Switch off and isolate the main power supply.
- All electrical components must be selected as per local standards and compressor requirements.
- Refer to page 1 for electrical connections details. For three phase applications, the terminals are labeled T1, T2, and T3.
- Danfoss scroll compressors will only compress gas while rotating counter-clockwise (when viewed from the compressor top). Three-phase motors, however, will start and run in either direction, depending on the phase angles of the supplied power. Care must be taken during installation to ensure that the compressor operates in the correct direction.
- Use \varnothing 4.8 mm / #10 - 32 screws and 1/4" ring terminals for the power connection with ring connect screw terminal (C type). Fasten with 3 Nm torque.
- Use a self tapping screw to connect the compressor to earth.

8 – Filling the system

- Keep the compressor switched off.
- Keep the refrigerant charge below the indicated charge limits if possible. Above this limit; protect the compressor against liquid flood-back with a pump-down cycle or suction line accumulator.
- Never leave the filling cylinder connected to the circuit.

Compressor models	Refrigerant charge limit
LLZ013-015-018	4.5 kg / 10 lb
LLZ024-033	7.2 kg / 16 lb

9 – Verification before commissioning

⚠ Use safety devices such as safety pressure switch and mechanical relief valve in compliance

with both generally and locally applicable regulations and safety standards. Ensure that they are operational and properly set.

⚠ Check that the settings of high-pressure switches don't exceed the maximum service pressure of any system component.

- A low-pressure switch is recommended to avoid low pressure operation.

(Minimum setting for R404A / R507) 1.3 bar (absolute) / 19 psia

- Verify that all electrical connections are properly fastened and in compliance with local regulations.
- When a crankcase heater is required, it must be energized at least 24 hours before initial start-up and start-up after prolonged shutdown.

10 – Start-up

- Never start the compressor when no refrigerant is charged.
- Do not provide any power to the compressor unless suction and discharge service valves are open, if installed.
- Energize the compressor. It must start promptly. If the compressor does not start, check wiring conformity and voltage on terminals.
- Eventual reverse rotation can be detected by following phenomena; the excessive noise, no pressure differential between suction and discharge, and line warming rather than immediate cooling. A service technician should be present at initial start-up to verify that supply power is properly phased and that the compressor is rotating in the correct direction. For LLZ compressors, phase monitors are required for all applications.
- If the internal overload protector trips out, it must cool down to 60°C / 140°F to reset. Depending on ambient temperature, this may take up to several hours.

11 – Check with running compressor

⚠ Check current draw and voltage. Measurement of amps and volts during running conditions must be taken at other points in the power supply, not in the compressor electrical box.

- Check suction superheat to reduce risk of slugging.
- Observe the oil level in the sight glass (if provided) for about 60 minutes to ensure proper oil return to the compressor.
- Respect the operating limits.
- Check all tubes for abnormal vibration. Movements in excess of 1.5 mm / 0.06 in require corrective measures such as tube brackets.
- When needed, additional refrigerant in liquid phase may be added in the low-pressure side as far as possible from the compressor. The compressor must be operating during this process.
- Do not overcharge the system.
- Never release refrigerant to atmosphere.
- Before leaving the installation site, carry out a general installation inspection regarding cleanliness, noise and leak detection.

- Record type and amount of refrigerant charge as well as operating conditions as a reference for future inspections.

12 – Maintenance

⚠ Internal pressure and surface temperature are dangerous and may cause permanent injury. Maintenance operators and installers require appropriate skills and tools. Tubing temperature may exceed 100°C / 212°F and can cause severe burns.

⚠ Ensure that periodic service inspections to ensure system reliability and as required by local regulations are performed.

To prevent system related compressor problems, following periodic maintenance is recommended:

- Verify that safety devices are operational and properly set.
- Ensure that the system is leak tight.
- Check the compressor current draw.
- Confirm that the system is operating in a way consistent with previous maintenance records and ambient conditions.
- Check that all electrical connections are still adequately fastened.
- Keep the compressor clean and verify the absence of rust and oxidation on the compressor shell, tubes and electrical connections.
- Acid / moisture content in system and oil should be checked regularly.

13 – Warranty

Always transmit the model number and serial number with any claim filed regarding this product.

The product warranty may be void in following cases:

- Absence of nameplate.
- External modifications; in particular, drilling, welding, broken feet and shock marks.
- Compressor opened or returned unsealed.
- Rust, water or leak detection dye inside the compressor.
- Use of a refrigerant or lubricant not approved by Danfoss.
- Any deviation from recommended instructions pertaining to installation, application or maintenance.
- Use in mobile applications.
- Use in explosive atmospheric environment.
- No model number or serial number transmitted with the warranty claim.

14 – Disposal



Danfoss recommends that compressors and compressor oil should be recycled by a suitable company at its site.