

Installation Guide

Pressure regulating valve OFV, OFV-SS 20-25 (40 bar version)

148R9520

148R9520

Installation

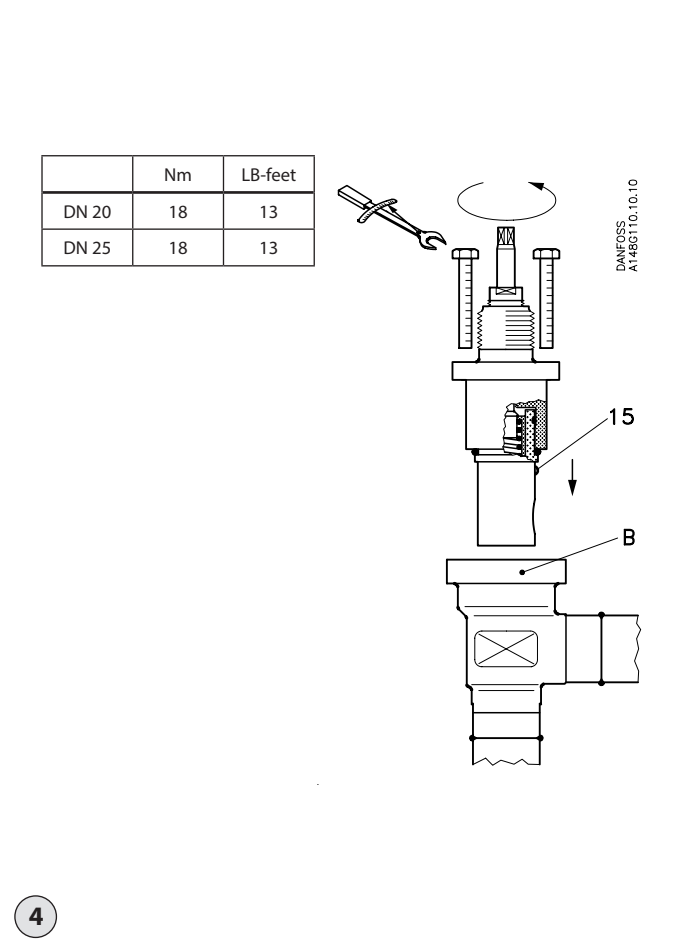
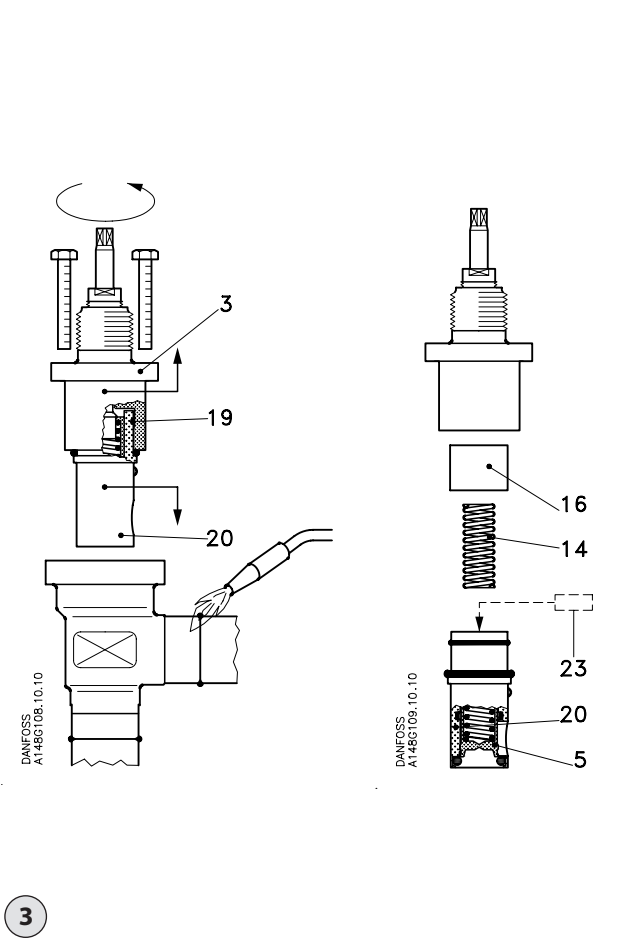
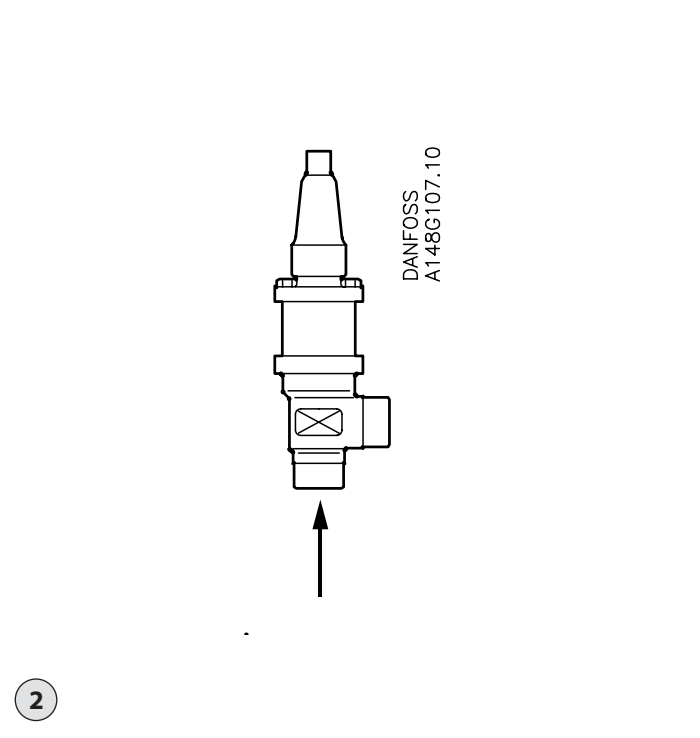
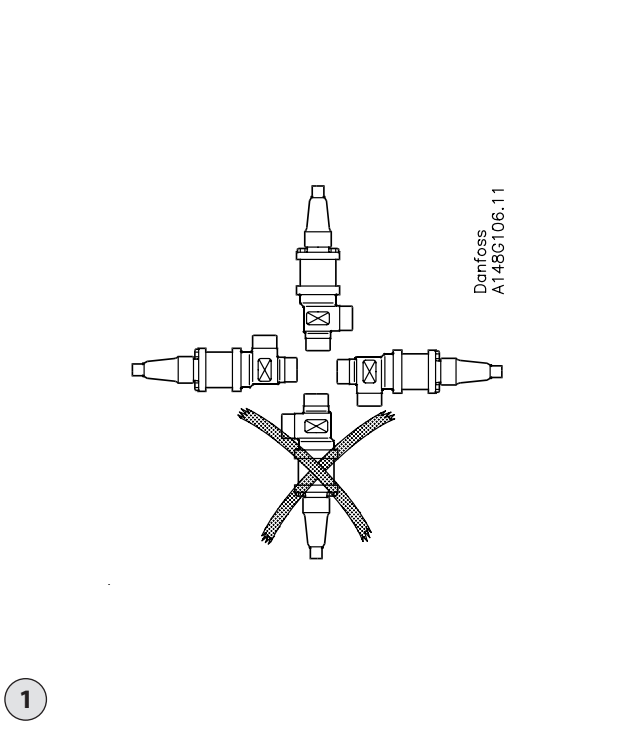

Maintenance

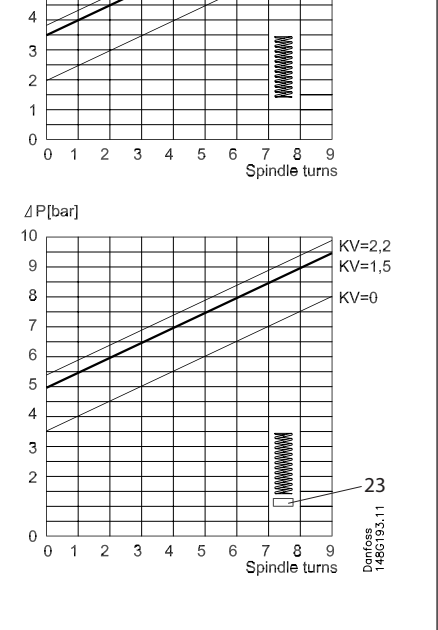
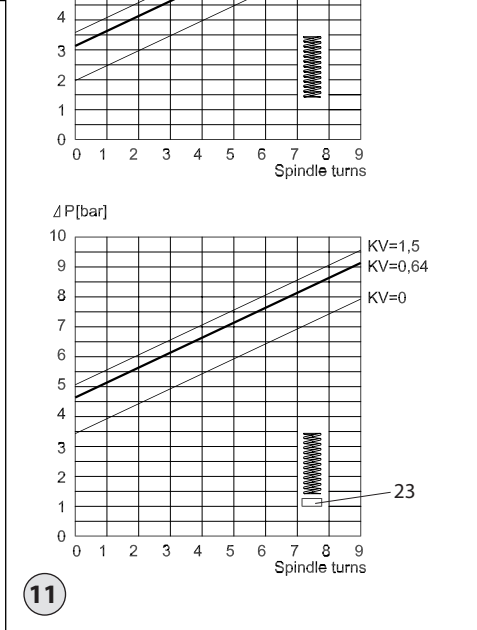
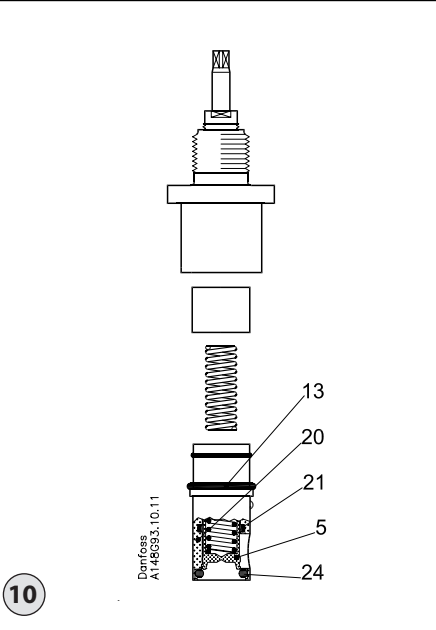
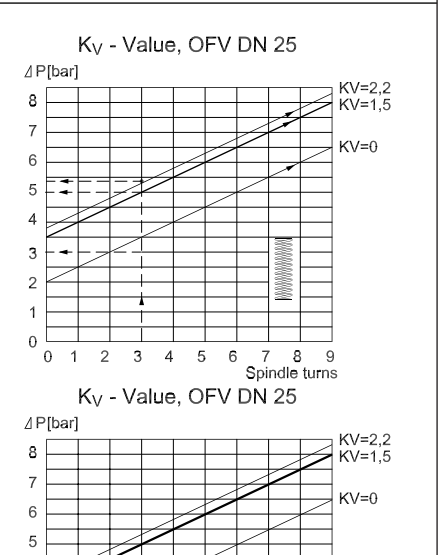
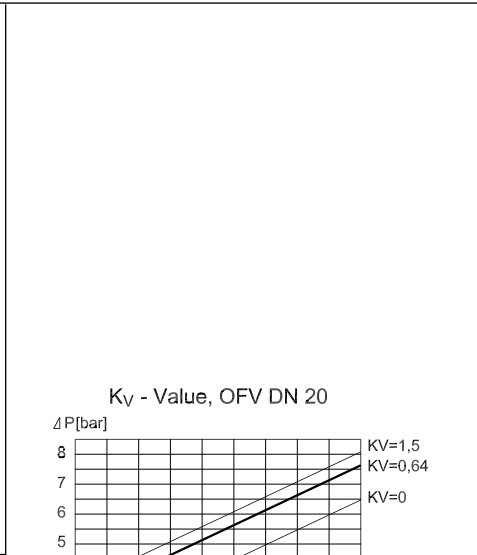
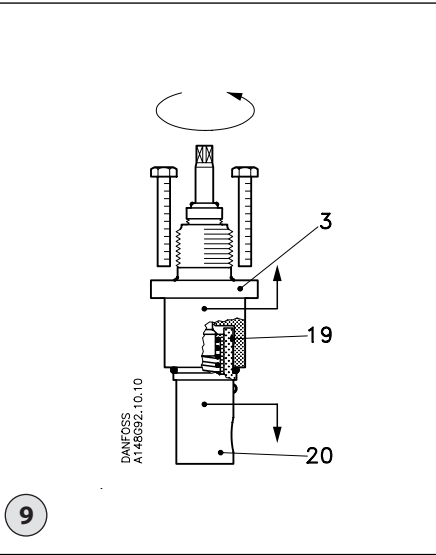
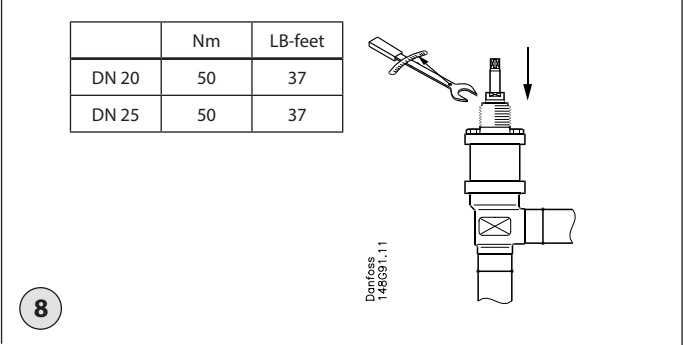
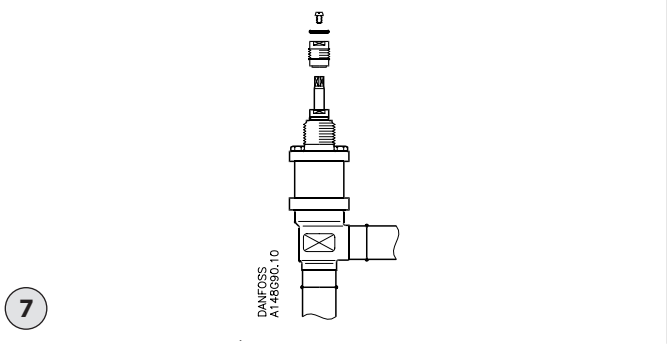
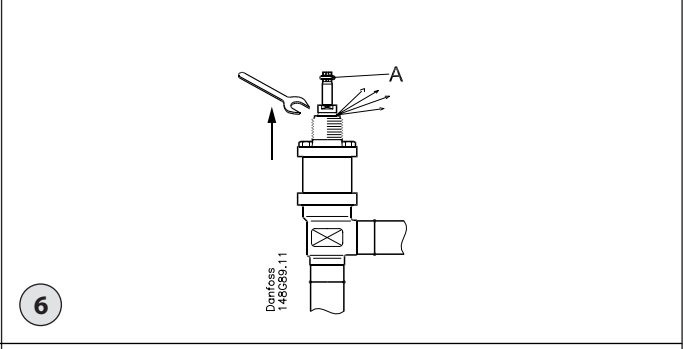
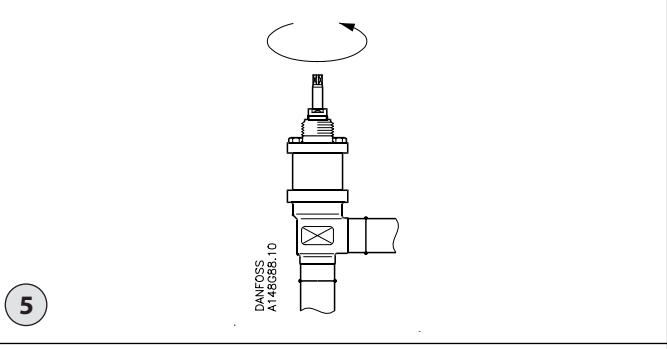

ENGLISH

Installation

Refrigerants

Applicable to HCFC, HFC, R717 (Ammonia) and R744 (CO₂).

Flammable hydrocarbons are not recommended. The valve is only recommended for use in closed circuits. For further information please contact Danfoss.

Temperature range

OFV: -50/+150°C (-58/+302°F)

OFV-SS: -60/+150°C (-76/+302°F)

Pressure range

The valves are designed for a max. working pressure of 40 bar g (580 psi g).

Installation

The valve must be installed with the spindle vertically upwards or in horizontal position (fig. 1). Valves should be opened by hand according to the guidelines in the datasheet. The valve is designed to withstand a high internal pressure. However, the piping system should be designed to avoid liquid traps and reduce the risk of hydraulic pressure caused by thermal expansion. It must be ensured that the valve is protected from pressure transients like "liquid hammer" in the system.

Recommended flow direction

Direct the flow towards the cone as indicated by the arrow placed on the valve housing (fig. 2). The force used to open and close the valve must not exceed the force of an ordinary handwheel.

Welding

The bonnet should be removed before welding (fig. 3) to prevent damage to the O-rings in the packing gland and between the valve body and bonnet, as well as the teflon gasket in the valve seat. Only materials and welding methods, compatible with the valve housing material, must be welded to the valve housing. The valve should be cleaned internally to remove welding debris on completion of welding and before the valve is reassembled.

Avoid welding debris and dirt in the threads of the housing and the bonnet.

Removing the bonnet can be omitted provided that:
The temperature in the area between the valve body and bonnet during welding does not exceed +150°C/+302°F. This temperature depends on the welding method as well as on any cooling of the valve body during the welding itself. (Cooling can be ensured by, for example, wrapping a wet cloth around the valve body.)

Make sure that no dirt, welding debris etc. get into the valve during the welding procedure.

Be careful not to damage the teflon cone ring.

The valve housing must be free from stresses (external loads) after installation.

Opening pressure

From factory the OFV will be covering differential pressure (ΔP) 2-6.5 bar (29-94.3 psig).

Adjust the differential pressure by turning the spindle as shown in fig. 11. If the above range is satisfactory please continue with "Assembly".

Alternatively, by mounting the distance piece, (pos. 23) the following range can be obtained: $\Delta P = 3.5-8$ bar (50.8-116 psig).

Mounting of distance piece (fig. 3)

Valve bonnet and guide are held together by O-ring (pos. 19). Separate the bonnet (pos. 3) and the guide (pos. 20) by pulling the pieces from each other. Now springshoe (pos. 16) and spring (pos. 14) can be removed. Then mount the distance piece (pos. 23), supplied separately together with the installation instruction, in the cone (pos. 5) at the bottom of the guide (pos. 20).

NB: Do not take cone and guide apart.

OFV valves must not be mounted in systems where the outlet side of the valve is open to atmosphere. The outlet side of the valve must always be connected to the system or properly capped off, for example with a welded-on end plate.

Assembly

Remove welding debris and any dirt from pipes and valve body before assembly. Check that the cone has been fully screwed back towards the bonnet before it is replaced in the valve body (fig. 4).

Tightening

Tighten the bonnet with a torque wrench, to the values indicated in the table (fig. 4).

Colours and identification

The OFV valves are painted with a red oxide primer in the factory. Stainless steel valves are not painted. Precise identification of the valve is made via the ID ring at the top of the bonnet, as well as by the stamping on the valve body. The external surface of the painted OFV valve housing must be prevented against corrosion with a suitable protective coating after installation and assembly.

Protection of the ID ring when repainting the valve is recommended.

Maintenance

Packing gland

When performing service and maintenance, replace the complete packing gland only, which is available as a spare part.

As a general rule, the packing gland must not be removed if there is internal pressure in the valve.

However, if the following precautionary measures are taken, the packing gland can be removed with the valve still under pressure:

Backseating (fig. 5)

To backseat the valve, turn the spindle counter-clockwise until the valve is fully open.

Pressure equalization (fig. 6)

In some cases, pressure forms behind the packing gland. Hence a handwheel or similar should be fastened on top of the spindle (pos. A) while the pressure is equalized. The pressure can be equalized by slowly screwing out the gland.

Removal of packing gland (fig. 7)

Cap and packing gland can now be removed.

Dismantling the valve (fig. 10)

Do not remove the bonnet while the valve is still under pressure.

- Check that the O-rings (pos. 13 & 24) have not been damaged.
- Check that spindle and cone (pos. 5) are free of scratches and impact marks.
- If the sealing ring (pos. 21) has been damaged, the whole cone assembly must be inspected carefully and maybe replaced.

Replacement of O-ring (fig. 10)

O-ring (pos. 24) seals between seat and cone. Therefore, it has to be changed if the valve is leaking. Use a pointed tool to dismount the O-ring (pos. 24). Check that cone (pos. 5) and guide (pos. 20) are not worn out. If these parts are worn out it is necessary to change the complete guide which consists of all wearing parts.

Assembly

Remove any dirt from the body before the valve is assembled. Check that the cone has been screwed back towards the bonnet before it is replaced in the valve body (fig. 4).

Tightening

Tighten the bonnet with a torque wrench, to the values indicated in the table (fig. 4). Tighten the packing gland with a torque wrench, to the values indicated in the table (fig. 8).

Use only original Danfoss parts, including packing glands, O-rings and gaskets for replacement. Materials of new parts are certified for the relevant refrigerant. In cases of doubt, please contact Danfoss.

Danfoss accepts no responsibility for errors and omissions. Danfoss Industrial Refrigeration reserves the right to make changes to products and specifications without prior notice.

