

Instruction

APP pumps

APP 0.6-1.0 / APP 1.5-2.5 / APP 3.0-3.5



Table of Contents	1.	Identification	3
	2.	System design	3
	2.1	Open-ended systems with water supply from a tank	3
	2.2	Open-ended systems with direct water supply.....	3
	2.3	Problems with reversing pumps	3
	2.4	General guidelines for calculation of pressure losses	4
	2.5	General comments on.....	4
	3.	Building up the pump unit	5
	3.1	Mounting.....	5
	3.2	Direction of rotation	5
	3.3	Orientation	6
	3.4	Protection from too high pressures.....	6
	3.5	Connections	6
	4.	Initial start-up.....	7
	5.	Operation.....	7
	5.1	Temperature.....	7
	5.2	Pressure	7
	5.3	Dry running.....	7
	5.4	Disconnection	7
	5.5	Storage.....	7
	5.5.1	Open-ended systems with water supply from tank.....	7
	5.5.2	Open-ended systems with direct water supply.....	8
6.	Service.....	8	
6.1	Periodic maintenance	8	
6.2	Repair	8	

1. Identification

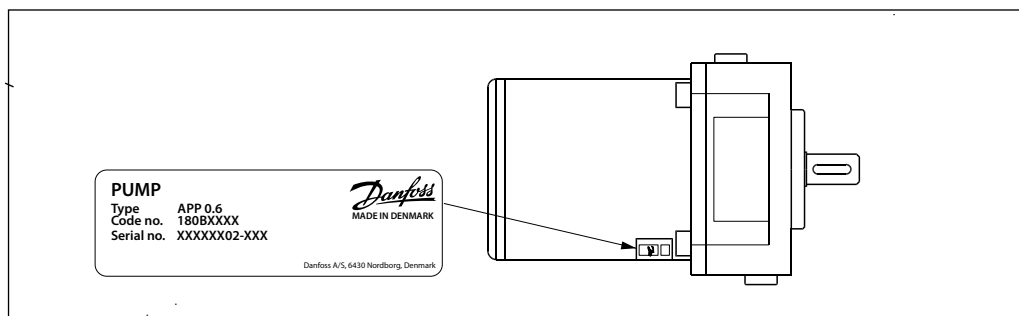

2. System design

The design of the system must ensure that self emptying of the pump during standstill is avoided.

The inlet pressure of the pump must never exceed the outlet pressure. This may typically occur in boosted or open-ended systems with direct water supply.

In order to avoid this it is recommended to install a pre-stressed check valve or a pressure switch in the pump inlet.

The opening pressure of the check valve must be bigger or equal to the inlet pressure.

2.1 Open-ended systems with water supply from a tank

(The numbers 1-3 refer to the drawing below.) In order to eliminate the risk of cavitation, observe the following guidelines:

- 1) Place the tank above the pump (water level in the tank should always be above the pump).
- 2) Place the inlet filter before the tank.
- 3) Dimension the inlet line to obtain minimum pressure loss (large flow area, minimum pipe length, minimum number of bends/connections, fittings with small pressure losses).

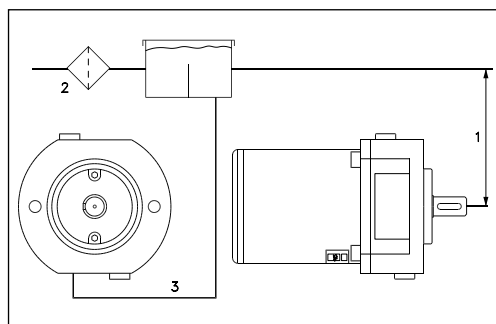

2.2 Open-ended systems with direct water supply

The pump is supplied with water direct from a booster pump.

The water pressure must not exceed 5 barg (72.5 psig).

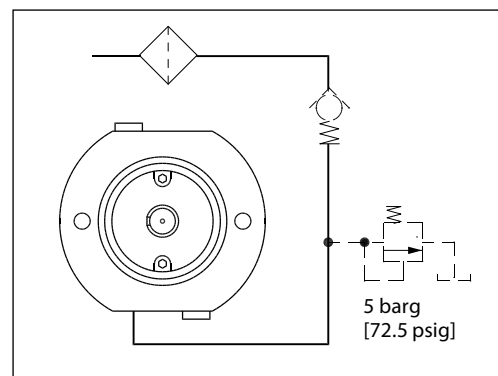

2.3 Problems with reversing pumps

If exposed to high pressure in the outlet while the electric motor is not energized, the pumps will start spinning backwards. This will not harm the pumps as long as the pressure in the inlet does not exceed the max. pressure of 5 barg.

If a non-return valve is mounted in the inlet line, a low-pressure relief valve will also be required. Alternatively a high-pressure check valve could be mounted in the pump discharge line to prevent the pump from reversing.

The dotted setup ensures that the inlet pressure does not exceed the 5 barg, when a non-return valve is mounted in the inlet.

2.4 General guidelines for calculation of pressure losses

In order to avoid the risk of cavitation, the inlet pressure at the pump must be in accordance with the specifications mentioned in Data sheet (521B1331).

The inlet line connection must be properly tightened, as possible entrance of air will cause cavitation.

The suction conditions can be optimized according to below guidelines.

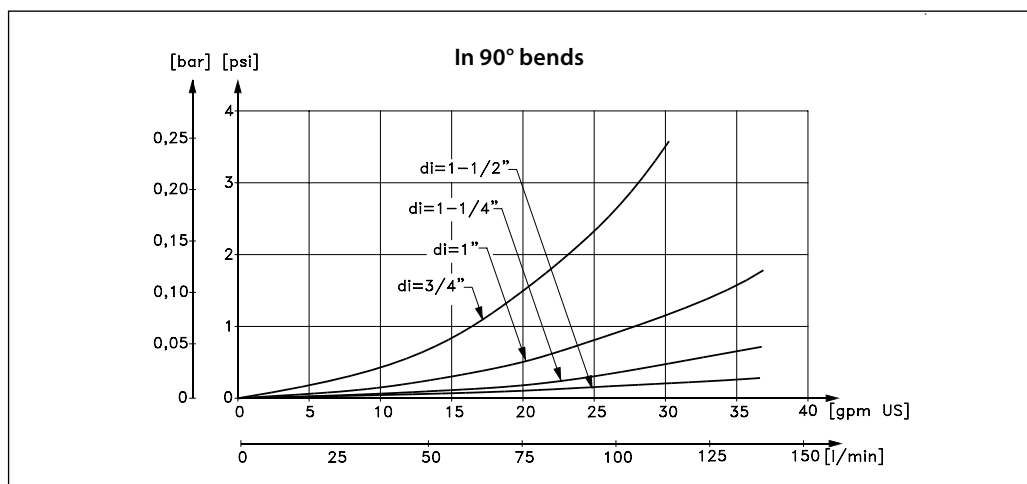
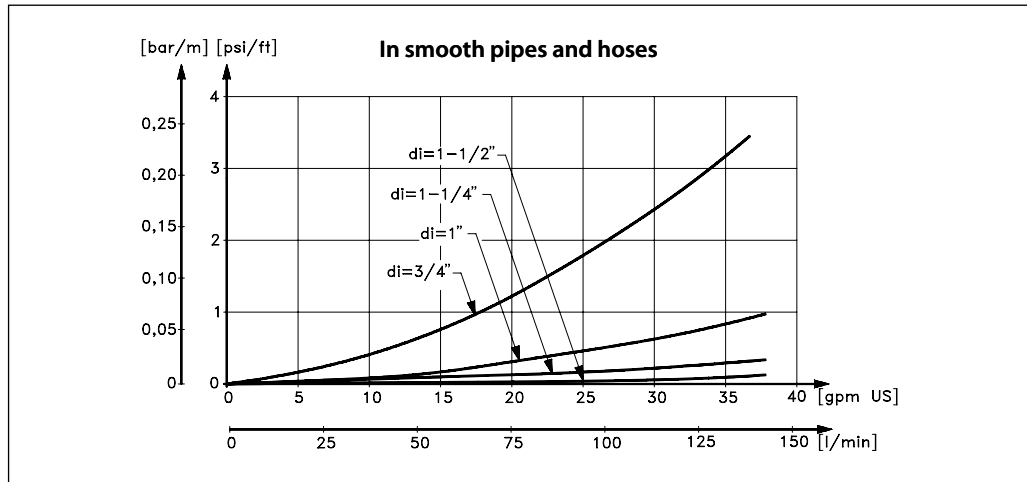

2.5 General comments on

Filtration

A good filtration is vital to ensure a long and trouble free life of the pump.

When selecting a filter or strainer, please note that filter materials should be compatible with water, i.e. should neither corrode or dissolve. Also be aware of the electrochemical series of the applied materials.

Main filter must have a fineness of $10 \mu m$ abs. $\beta_{10} \geq 5000$. The pressure loss across the filter should be monitored.

Water tank

Must be made of corrosion-proof material such as stainless steel or plastic and must be sealed to prevent entrance of impurities from the environment.

Automatic pressure equalization between tank and surroundings must be ensured.

Inlet from the water supply and inlet to the pump should be placed in opposite ends of the tank to calm and deaerate the water, and to ensure optimum opportunity for particles to settle.

Pump suction line should be placed relatively high above the tank bottom in order to prevent settled particles from being led into the pump.

We recommend a separation ("wall") to separate the inlet from the outlet end of the tank.

Monitoring

It is recommended to continuously monitor the following conditions:

- Water level in the tank
- Filter contamination
- Pressure (inlet- and outlet side of the pump)

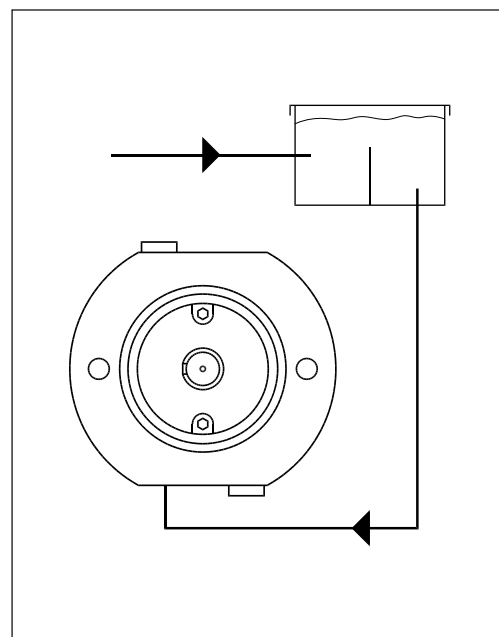

3. Building up the pump unit

3.1 Mounting

(Please also see hints in "Right and Wrong")

If alternative mounting is desired, please contact the Danfoss High Pressure Pumps.

Choose proper tolerances to ensure an easy mounting of the elastic coupling without use of tools.

Please take care to observe the recommended length tolerances of the chosen coupling, as an axial force on the pump will damage the pump.

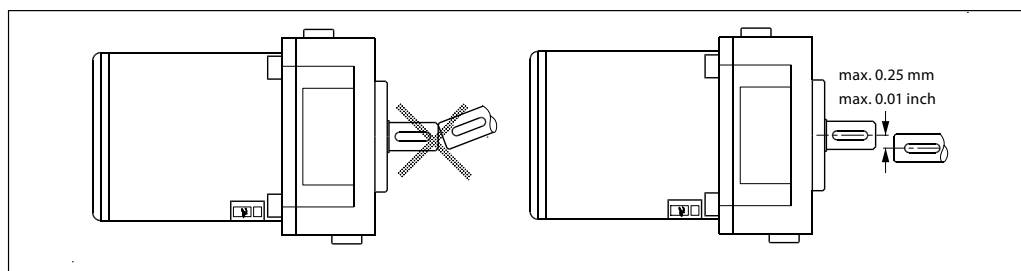
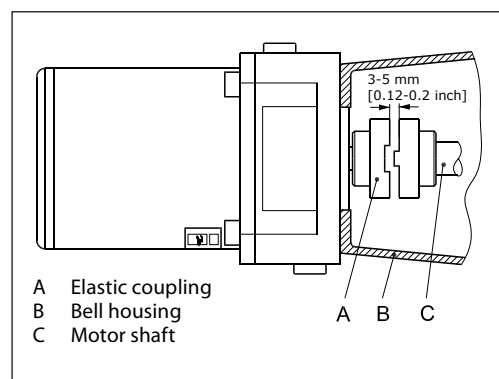

3.2 Direction of rotation

Is indicated by an arrow at the pump label.

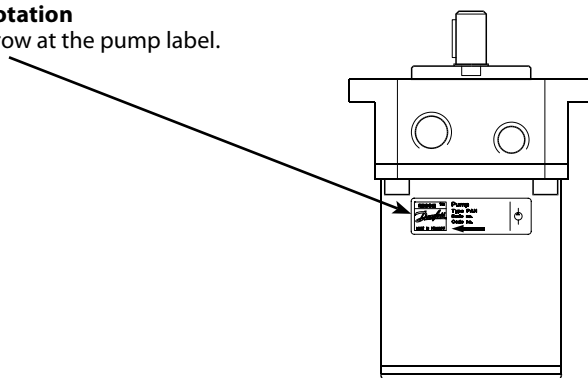

3.3 Orientation

The pump can be mounted/oriented in any horizontal direction. Vertically only with the shaft pointing upwards.

The valve should be placed as close to the pump as possible. The opening characteristics of the valve must not result in peak pressures higher than 200 barg (2900 psig).

3.4 Protection from too high pressures

The pump should be protected against too high pressure by means of a pressure relief valve or a bypass/unloading valve placed on the pressure side.

The valve outlet must not be connected directly to the pump suction line. It shall be connected directly to the tank.

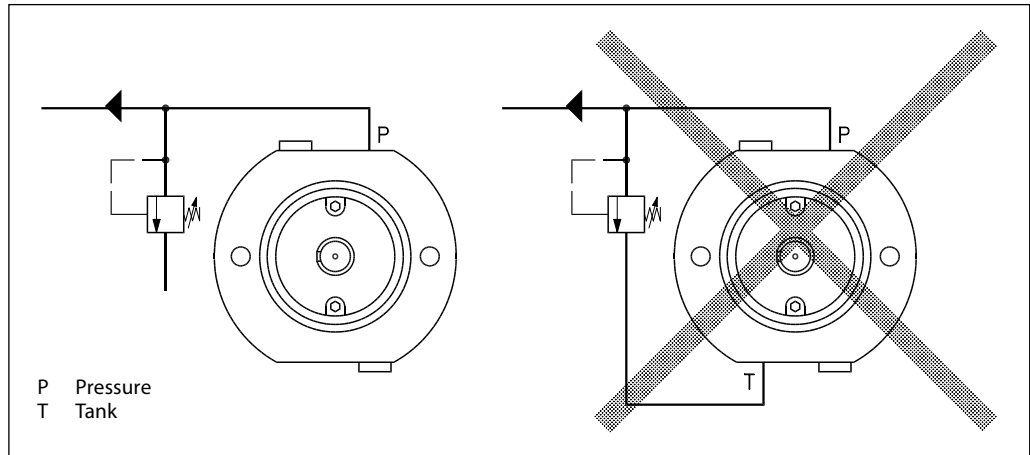

3.5 Connections

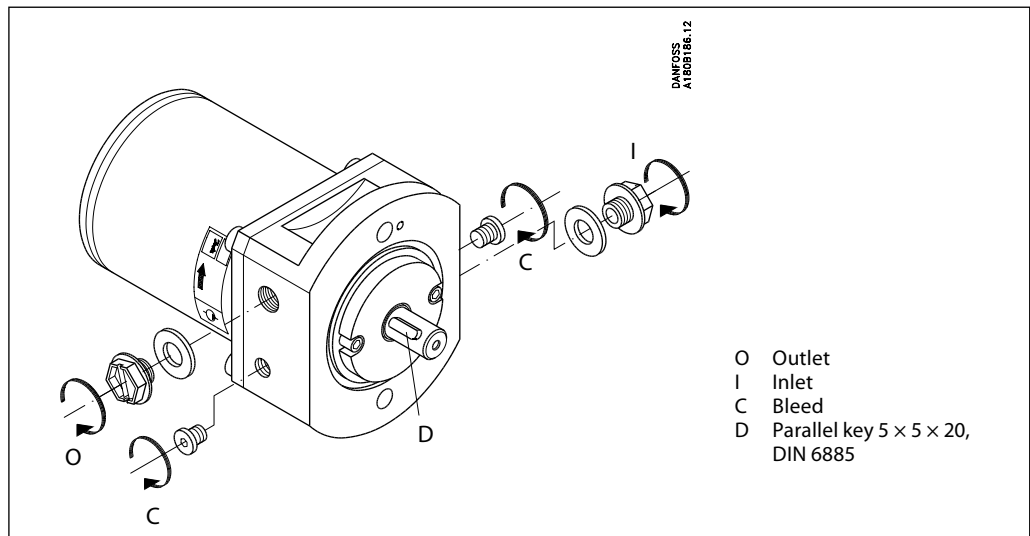

	APP 0.6-1.0		APP 1.5-2.5 and APP 3.0-3.5		
	O	I	O	I	C
Thread size	G 1/2 × 13	G 1/2 × 13	G 3/4 × 16	G 3/4 × 16	M6 Hexagon 5 mm key
Max tighten torque	65 Nm 48 (lbf ft)	65 Nm 48 (lbf ft)	90 Nm 66 (lbf ft)	90 Nm 66 (lbf ft)	5 Nm 3.5 (lbf ft)

Contact your fittings supplier for tightening torque requirements. Recommended torque values refer to steel washers containing a rubber sealing element.

4. Initial start-up

Before start-up, loosen the top bleeding plug "C", except for APP 0.6 - 1.0. When water appears from the bleeding plug, retighten the plug. With its inlet line connected to the water supply or the tank, the pump is now started with open outlet port.

At the initial start of the system, the pump should be run without pressure for about 5 minutes, thus removing possible impurities from pipes, hoses, etc. **However, the system should be flushed before start-up – without the connected pump.**

WARNING:

Make sure that the direction of rotation of the electric motor corresponds to the direction of rotation of the pump. Otherwise the pump will be damaged if a check valve is placed between pump and tank.

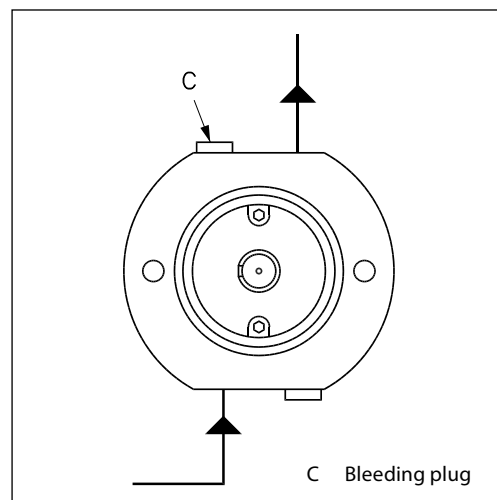

5. Operation

5.1 Temperature

Fluid temperature: Min. +2° C to max. +50° C Min. +35.6° F to max. +122° F
Ambient temperature: Min. +2° C to max. +50° C Min. +35.6° F to max. +122° F

In case of lower operating temperatures, please contact Danfoss High Pressure Pumps.

5.2 Pressure

The inlet pressure must be min. 0.5 barg (7.25 psig) and max. 5 barg (72.5 psig). At lower pressures the pump will cavitate, resulting in damage to the pump.

Max. pressure on the pump's outlet line should be limited at 80 barg (1160 psig) continuously. Short-term pressure peaks (e.g. in connection with closing of a valve) of up to 100 barg (1450 psig) are acceptable.

NB:

The pump unit should include a pressure gauge on the high pressure side.

5.3 Dry running

When running, the pump must always be connected to the water supply in order to avoid damage if it should run dry.

In systems with water tank it is recommended to build in a level gauge in the tank to avoid the risk of running dry.

5.4 Disconnection

If the inlet line is disconnected from the water supply, the pump will be emptied of water through the disconnected inlet line.

When starting up again, follow the bleeding procedure described under section 4: Initial start up.

5.5 Storage

Frost protection:

Storage temperature: Min. -40° C to max. +70° C Min. -40° F to max. +158° F

When preparing the pump for long-term storage or for temperatures below the freezing point, flush the pump with an anti-freeze medium type monopropylene glycol to prevent internal corrosion or frost in the pump.

For further information on anti-freeze media, please contact Danfoss High Pressure Pumps.

Recommended procedure:

5.5.1 Open-ended systems with water supply from tank

1. Empty the tank of water and empty the pump housing through the lower bleeding plug. When the pump is empty, retighten the plug.
2. Through the upper bleeding plug, fill the pump housing with anti-freeze medium. Pour anti-freeze medium into the tank. Connect a hose to the outlet of the pump and lead the other end of the hose back to tank.
3. Quickly start and stop the pump. Make sure that the pump does not run dry. The pump is now protected against internal corrosion and frost.

5.5.2 Open-ended systems with direct water supply

1. Disconnect the water supply to the pump.
2. Through the lower bleeding plug, empty the pump housing of water and close it again.
3. Connect the pump to a tank of e.g. 25 litre (6 gal.) of anti-freeze additive. Connect a hose to the inlet port of the pump and via another hose return the flow from the outlet port to the tank with anti-freeze additives.
4. Quickly start and stop the pump. Make sure that the pump does not run dry. The pump is now protected against internal corrosion and frost.

Storage:

Storage of the pump that have been in operation:

For shorter periods of storage flush the pump with permeate rotating the pump for 10 sec. empty permeate and store.

For long term storage (more than 2 months) Danfoss recommends servicing the product and clean any biological growth of the surfaces. Store the pump dry without water inside.

6. Service

6.1 Warranty

Danfoss APP pumps are designed for long operation, low maintenance and reduced lifecycle costs.

Provided that the pump has been running according to the Danfoss specifications, Danfoss guarantees 8,000 hours service-free operation, however, max. 18 months from date of production. If Danfoss recommendations concerning system-design are not followed, it will strongly influence the life of the APP pumps.

6.2 Maintenance

After 8,000 hours of operation, it is recommended to inspect the pump and change any worn parts, e.g. pistons.

This is done in order to prevent a potential breakdown on the pump. If the parts are not replaced, more frequent inspection is recommended according to our guidelines.

Pump shutdown:

The APP pumps are made of Duplex/Super Duplex materials with excellent corrosion properties. It is however, always recommended to flush the pump with fresh water when the system is shut down.

When stopping the pump for more than 1 day, flush the pump with permeate by rotating the pump for 10 sec. Flushing through the flushing valve of the pump without rotating the pump is not enough for cleaning the inside of the pump. The pump can be flushed with biocide like the membranes. The biocide must be compatible with the materials used in our pump (materials can be found in the parts list in the Operating Guide)

6.3 Repair

In case of irregular function of the APP pump, please contact Danfoss High Pressure Pumps sales organisation.

Danfoss A/S
High Pressure Pumps
Nordborgvej 81
DK-6430 Nordborg
Denmark

Danfoss can accept no responsibility for possible errors in catalogues, brochures and other printed material. Danfoss reserves the right to alter its products without notice. This also applies to products already on order provided that such alterations can be made without consequential changes being necessary in specifications already agreed. All trademarks in this material are property of the respective companies. Danfoss and the Danfoss logotype are trademarks of Danfoss A/S. All rights reserved.