

Data sheet

Standard JIP™ ball valves

Description



Danfoss Standard JIP™ ball valves is a range of reduced bore shut off valves developed for District Heating and District Cooling networks, with circulating medium.

It is a range of steel ball valves with fully welded body.

The valve design makes them ideal for building installation due to:

- Energy saving: with optimum flow design valves have highest kv on the market and consequently lowest pump energy costs.
- Long lifetime and optimal tightness due to design and material selection in ball seal (carbon reinforced PTFE) and stem seal (graphite).
- The valves are maintenance free, besides the shut off valves in the core distribution network Danfoss offers a range of supplementary valves, e.g. hot tap valves, branching valves, twin valves and draining valves.

Main data:

- DN 15-600
- $k_{vS} = 8-26300 \text{ m}^3/\text{h}$
- PN 16 / 25 / 40
- Leakage rate A (according to EN12266-1) - both directions
- Temperature: 0 ... 180 °C
- Medium: Circulation water / glycolic water up to 50 %
- Min. storage and transport temperature: -40 °C

Approvals and norms:

- 100 % final inspection. Leak and shell test as well as dimension and functionality test is performed on each and every valve according to applicable standard (EN 12266 part 1 P10-P11-P12 & part 2 F20).
- PED Directive 2014/68/EU Modul H1
- Danfoss A/S is certified according to ISO 9001
- Furthermore certified according to ISO 14001 and ISO45001.

Ordering

JIP-WW welding
JIP-FF flange

JIP-WW welding			JIP-FF flange			
Code No.						
DN (mm)	WW PN 25	WW PN 40	DN (mm)	FF PN 16	FF PN 25	FF PN 40
15	-	065N1100	15	-	-	065N1101
20		065N0105	20			065N0305
25		065N0110	25			065N0310
32		065N0115	32			065N0315
40		065N0120	40			065N0320
50		065N0125	50			065N0325
65	065N3600	-	65	065N3606	065N3612	-
80	065N3601		80	065N3607	065N3613	
100	065N3602		100	065N3608	065N3614	
125	065N3603		125	065N3609	065N3615	
150	065N3604		150	065N3610	065N3616	
200	065N3605		200	065N3611	065N3617	

JIP-WW welding			JIP-FF flange			
DN (mm)	Code No. WW PN 25		Code No. FF PN 16		Code No. FF PN 25	
	Valve with worm gear	Valve with gear flange	Valve with worm gear	Valve with gear flange	Valve with worm gear	Valve with gear flange
65	065N3618	065N3636	065N3624	065N3642	065N3630	065N3648
80	065N3619	065N3637	065N3625	065N3643	065N3631	065N3649
100	065N3620	065N3638	065N3626	065N3644	065N3632	065N3650
125	065N3621	065N3639	065N3627	065N3645	065N3633	065N3651
150	065N3622	065N3640	065N3628	065N3646	065N3634	065N3652
200	065N3623	065N3641	065N3629	065N3647	065N3635	065N3653
250	065N0161	065N0162	065N0216	065N0262	065N0361	065N0362
300	065N0166	065N0167	065N0266	065N0267	065N0366	065N0367
350	065N0171	065N0172	065N0271	065N0272	065N0371	065N0372
400	065N0176	065N0177	065N0276	065N0277	065N0376	065N0377
450	065N0178	065N0179	065N0278	065N0279	065N0378	065N0379
500	065N0181	065N0182	065N0281	065N0282	065N0381	065N0382
600	065N0186	065N0187	-			

JIP-II internal thread
JIP-IW internal thread/welding

JIP-II internal thread			JIP-IW internal thread / welding		
DN (mm)	Code No. II PN 40		DN (mm)	Code No. IW PN 40	
	L-handle high stem	T-handle low stem		L-handle high stem	T-handle low stem
15	065N0800	065N0802	15	065N0900	065N0904
20	065N0805	065N0807	20	065N0905	065N0908
25	065N0810	065N0812	25	065N0910	065N0914
32	065N0815	-	32	065N0915	-
40	065N0820		40	065N0920	
50	065N0825		50	065N0925	

Ordering

JIP-FW flange/welding

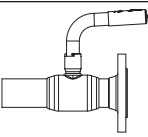
			
JIP-FW flange / welding			
DN (mm)	Code No.		
	PN 16	PN 25	PN 40
15			065N1102
20			065N0705
25			065N0710
32			065N0715
40			065N0720
50			065N0725
65	065N3654	065N3660	
80	065N3655	065N3661	
100	065N3656	065N3662	
125	065N3657	065N3663	
150	065N3658	065N3664	
175			
200	065N3659	065N3665	

Copper valves

JIP-CC copper

JIP-IC internal thread /copper

Max temp. 130°

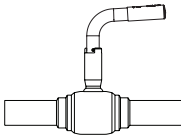
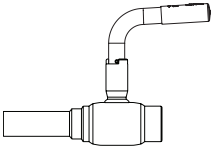
			
JIP-CC copper		JIP-IC internal thread / copper	
DN (mm)	Code No.		
	CC PN 16	IC PN 16	
15	065N4058	065N4057	
20	065N4067	065N4064	
25	065N4095	065N4087	

Copper twin valves for single

pipe connection

JIP-IC internal thread / copper

Max temp. 130°

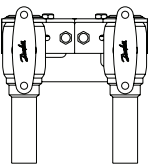
	
JIP-IC internal thread / copper	
DN (mm)	Code No.
	IC PN 16 with T-handle
15	065N4195
20	065N4071

Twin valves for single pipe

connection

T-handle (DN 15-25) or

L-handle (DN 32)

JIP- WW welding

JIP-II internal thread

JIP IW internal thread / welding

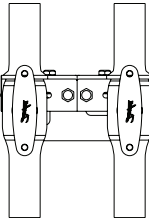
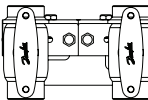
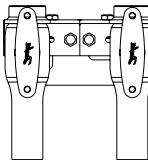
					
JIP-WW welding		JIP-II internal thread		JIP-IW internal thread / welding	
DN (mm)	Code No.				
	WW PN 40	II PN 40		IW PN 40	
15	065N4001	065N0801		065N0901	
20	065N4002	065N0806		065N0906	
25	065N4003	065N0811		065N0911	
32	065N4004	065N0816		065N0916	

Ordering

Twin valves for double pipe connection
T-handle
JIP-IW internal tread / welding
JIP-II internal thread

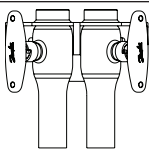
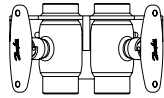
			
JIP-IW internal thread / welding		JIP-II internal thread	
DN (mm)	Code No.		
	IW PN 40	II PN 40	
15	065N7032	065N7022	
20	065N7034	065N7024	
25	065N7036	065N7026	

Draining valves

JIP-WE cc welding/external thread with closing cap

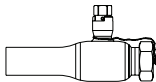
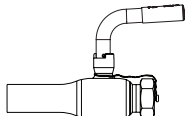
			
JIP-WE cc welding / external thread with closing cap			
DN (mm)	Code No.		
	WE PN 40-hex vers.	WE PN 40-L-handle	
15	065N4322	065N4422	
20	065N4323	065N4423	
25	065N4324	065N4424	
32	065N4325	-	
40	065N4326		
50	065N4327		

Worm gear

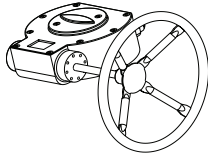
		
Description	Worm gear	Position indicator with end switch
Worm gear for DN 65 reduced bore	065N0683	065N0694
Worm gear for DN 80-100 reduced bore	065N0684	065N0695
Worm gear for DN 125 reduced bore	065N0784	065N0695
Worm gear for DN 150 reduced bore	065N0785	065N0695
Worm gear for DN 200 reduced bore	065N0685	065N0695
Worm gear for DN 250 reduced bore	065N0691	065N0696
Worm gear for DN 300-350 reduced bore	065N0687	065N0697
Worm gear for DN 400 reduced bore	065N0688	065N0698
Worm gear for DN 450-600 reduced bore	065N0689	065N0699
Position indicator: Temperature -15 ... 80°C, IP65		
Worm gear: Temperature -20 ... 120°C, IP67		

**Ordering
Accessories**

Replacement handles		
Type of handle	Fixation	Code No.
T Alu. DN 15-25	spring pin	065N8255
L Steel DN 15-32 with plastic grip	spring pin	065N8256
L Steel DN 40-50 with plastic grip	spring pin	065N8257
L Steel DN 65 with plastic grip	spring pin	065N3720
L Steel DN 80 with plastic grip	spring pin	065N3721
L Steel DN 100 with plastic grip	spring pin	065N3722
L Steel DN 125 with plastic grip	spring pin	065N3723
L Steel DN 150 with plastic grip	spring pin	065N3724
L Steel angled DN 200 with plastic grip	screw	065N3726

Handles with extended shaft for pipes with thick insulation						Picture
Type of handle	Code No.	Valve DN	H	h	S	
Handle DN15-32 RB L115-H	065N8350	15	142	196	115	
		20	142	196	115	
		25	142 (157) ¹⁾	199 (214) ¹⁾	115	
		32	141 (155) ¹⁾	204 (218) ¹⁾	115	
Handle DN 40-50 RB L157-H	065N8351	40	170 (201) ¹⁾	248 (279) ¹⁾	157	
		50	174 (200) ¹⁾	252 (284) ¹⁾	157	
Handle DN 65 RB L205-H	065N8352	65	188	283	205	
Handle DN 80-100 RB L405-H	065N8353	80	210	334	405	
		100	227	367	405	
Handle DN 125 RB L505-H	065N8354	125	225	412	505	
Handle DN 150 RB L645-H	065N8355	150	231	451	645	
Handle DN200RB L645-HexT-H	065N8356	200	245	492	645	

¹⁾ Valid for flanged version (FF)

Marking knobs for T handles DN15-32 (red/blue)	
Description	Code No.
Red knobs (bag with 100 pieces)	065N8303
Blue knobs (bag with 100 pieces)	065N8304

Insulation covers				
Picture	Description	Fit to valve DN's	Material	Code No.
	JIP-ACC insulation TWD DN15-20 I-p 12pcs	15, 20	Extruded polypropylene (EPP)	065N8326
	JIP-ACC insulation TWS DN15-20 I-p 12pcs			065N8327

* Insulation packed in industry pack (12pcs/pack)

** 065N8327 could be used for TWIN valves for single pipe connection (TWS) and for JIP reduced bore Single Ball valves

Technical data

DN [mm]	15	20	25	32	40	50	65	80	100	125	150	200	250	300	350	400	450	500	600	
K_{vs} [m ³ /h]	8/11*	15	34	52	96	184	195	495	610	1050	1850	2150	5100	9100	7000	10400	26300	23700	14300	
PN	16/25/40						16/25													
Temp range	0-180 °C																			
Medium	Circulation water / glycolic water up to 50 %																			

* K_{vs} for the codes 065N1100, 065N1101 and 065N1102 is 8 [m³/h], K_{vs} for all other DN 15 codes is 11 [m³/h]

Design & Material

1	Welding end	*Weldable mild steel 20#
1A	Flange	*Weldable mild steel 20#
2	Shell	*Weldable mild steel 20#
3	Ball	Stainless steel
4	Ball seal	Carbon reinforced PTFE
5	Stem	Stainless steel
6	Washer	Carbon reinforced PTFE
7	Stem sealing rings	Graphite
8	Compression nut	Steel
9	Packing box	*Weldable mild steel 20#
10	Pin	Spring steel
11	Handle	Steel

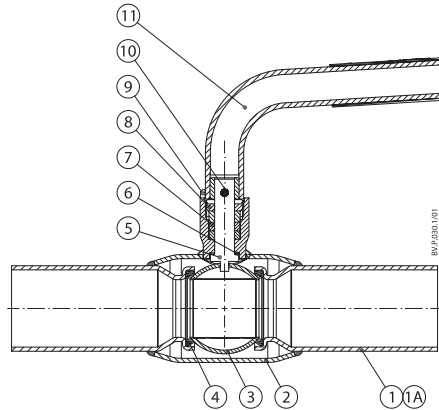

DN 15-50 with handle

1	Welding end	*Weldable mild steel 20#
1A	Flange	*Weldable mild steel 20#
2	Shell	*Weldable mild steel 20#
3	Ball	Stainless steel
4	Pipe insert	Stainless steel
5	Support ring	Stainless steel
6	Disc spring	Spring steel (50CrVA)
7	Ball seal	Carbon reinforced PTFE
8	Stem	Stainless steel
9	Washer	Carbon reinforced PTFE
10	Stem sealing rings	Graphite
11	Compression ring	Steel
12	Compression nut	Steel
13	Packing box	*Weldable mild steel 20#
14	Pin	Spring steel
15	Handle	Steel

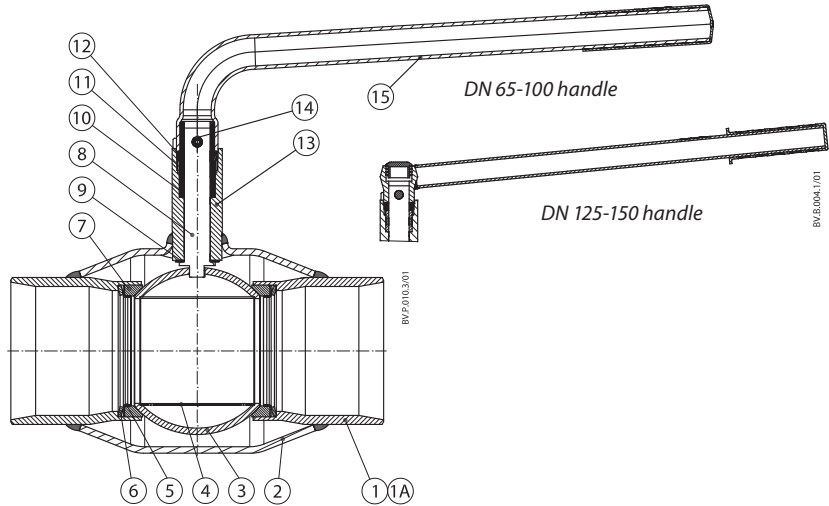

DN 65-150 with handle

1	Welding end	*Weldable mild steel 20#
1A	Flange	*Weldable mild steel 20#
2	Shell	*Weldable mild steel 20#
3	Ball	Stainless steel
4	Pipe insert	Stainless steel
5	Ball seal	Carbon reinforced PTFE
6	Ball seal support ring	Stainless steel
7	Disc spring	Spring steel (50CrVA)
8	Stem	Stainless steel
9	Washer	Carbon reinforced PTFE
10	Stem sealing rings	Graphite
11	Compression ring	Steel
12	Compression nut	Steel
13	Packing box	*Weldable mild steel 20#
14	Pin	Spring steel
15	Handle	Steel

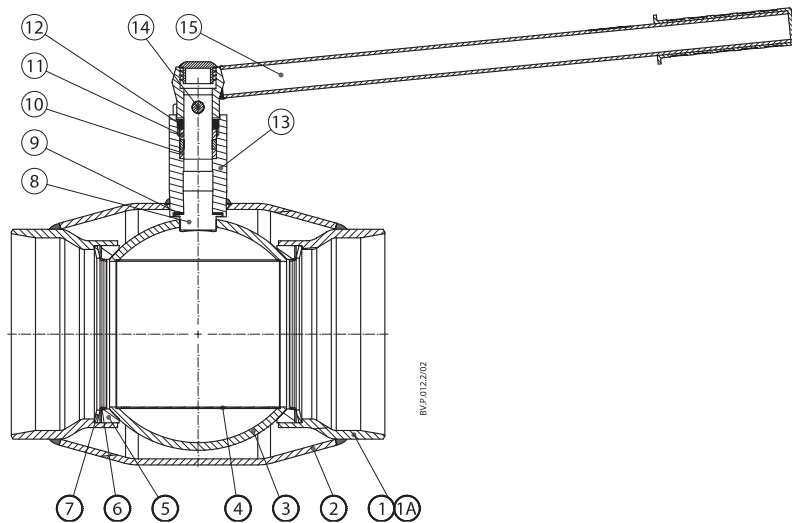

DN 200 with handle

Design & Material

1	Welding end	*Weldable mild steel 20#
1A	Flange	*Weldable mild steel 20#
2	Shell	*Weldable mild steel 20#
3	Ball	Stainless steel
4	Guide pipe	Stainless steel
5	Ball seal	Carbon reinforced PTFE
6	Ball seal support ring	Stainless steel
7	Disc spring	Spring steel (50CrVA)
8	Stem	Stainless steel
9	Washer	Carbon reinforced PTFE
10	Stem sealing rings	Graphite
11	Compression ring	Steel
12	Compression nut	Steel
13	Gear flange	Steel
14	Key	Steel

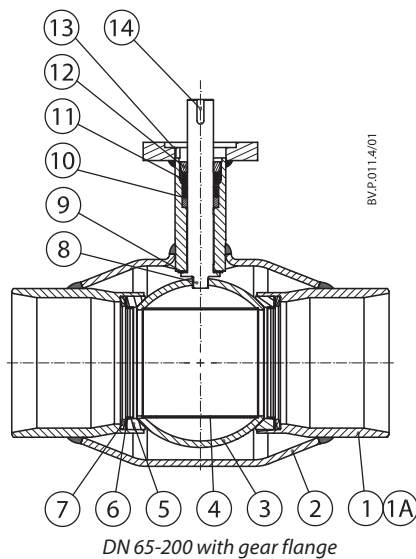

1	Welding end	*Weldable mild steel 20#
1A	Flange	*Weldable mild steel 20#
2	Guiding pipe	*Weldable mild steel 20#
3	Shell	*Weldable mild steel 20#
4	Ball seal retainer	*Weldable mild steel 20#
5	Ball	Stainless steel
6	Guide pipe	Stainless steel
7	Ball seal	Carbon reinforced PTFE
8	Disc spring	Domex 650 MC
9	Stem	Stainless steel
10	Washer	Carbon reinforced PTFE
11	Packing box	*Weldable mild steel 20#
12	Stem sealing rings	Graphite
13	Compression ring	Steel
14	Compression nut	Steel
15	Simmerring	Rubber
16	Key	Steel

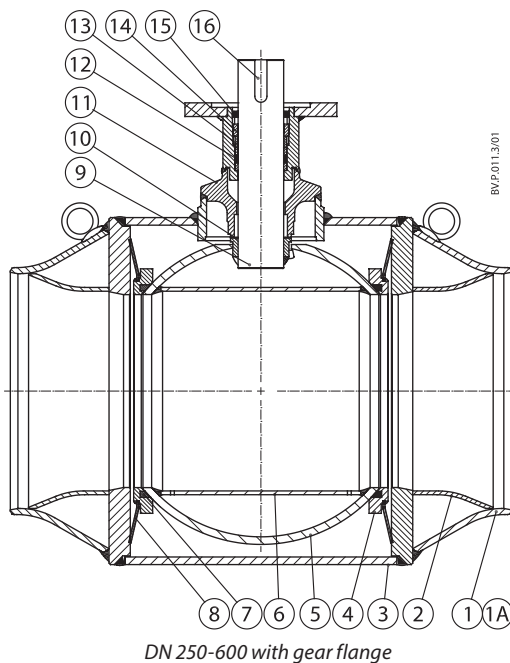

* According to the GB/T8163. Or equivalent mild steel in accordance with CE-PED

Technical data

Pressure drop/velocity

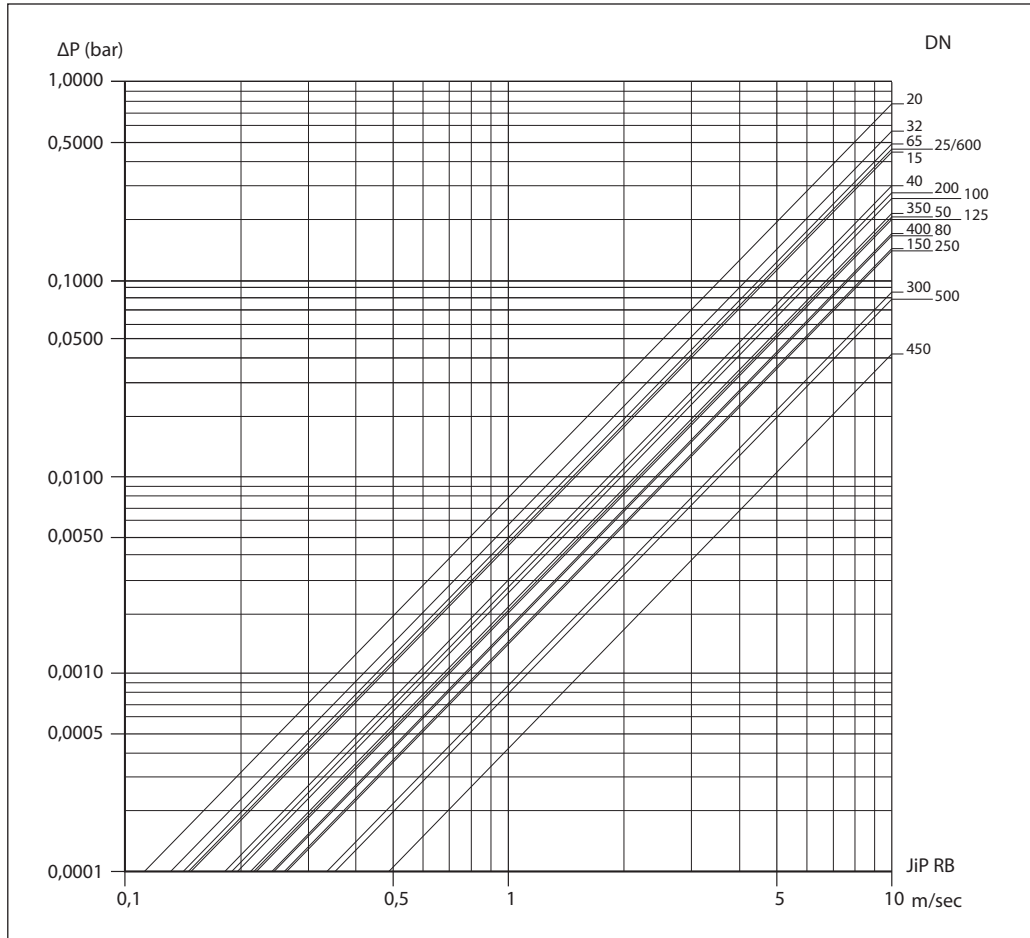

Technical data

Pressure drop/flow

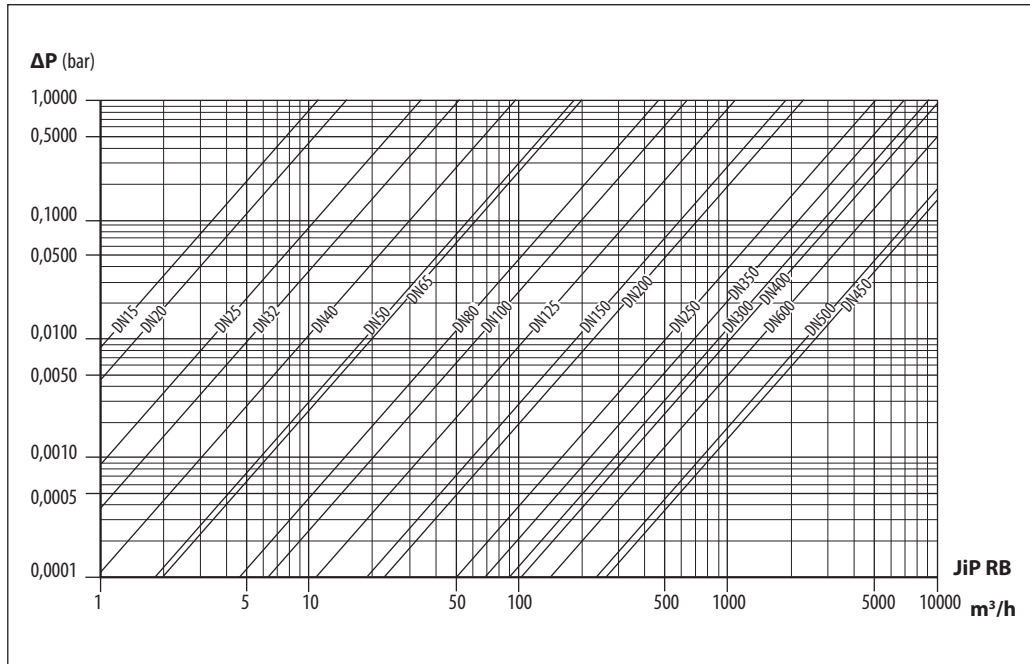

Pressure/temperature
JIP-WW

DN 15-50

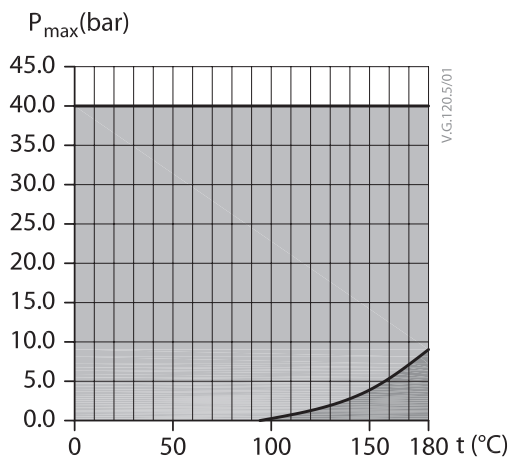

DN 65-600

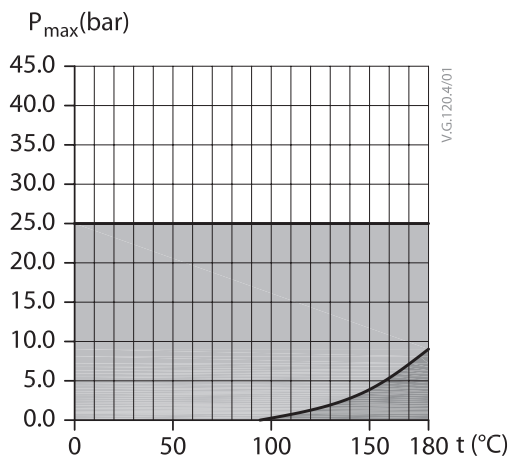

Legend:

- Normal operating area (water)
- Steam area

Pressure/temperature
JIP-FF

PN 16, DN 65-600

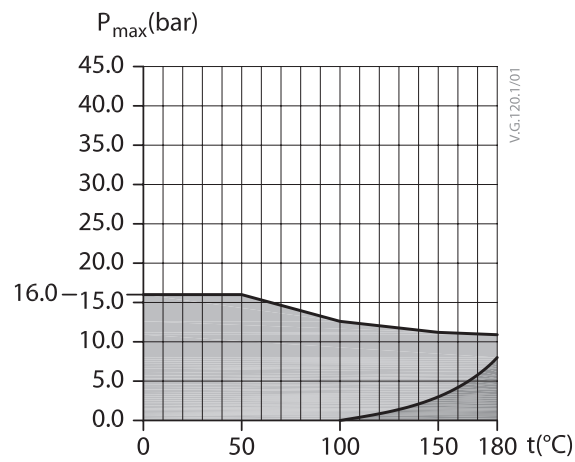

PN 25, DN 65-600

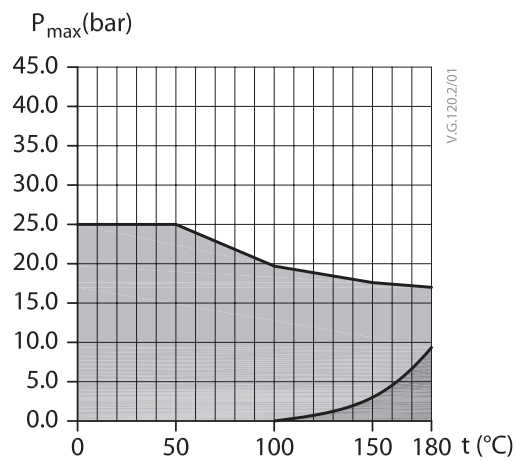

PN 40, DN 15-50

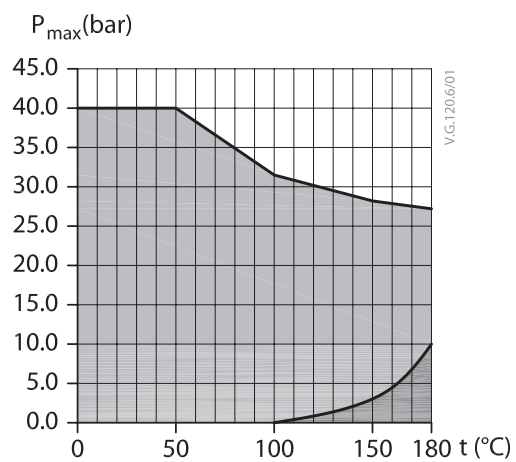

Legend:

- Normal operating area (water)
- Steam area

Dimensions

JIP-WW welding/
welding

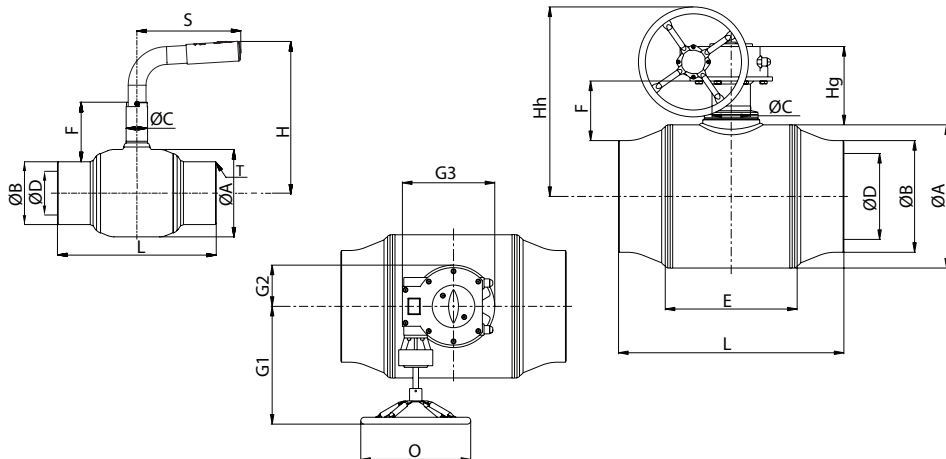

DN (mm)	ØA	T	ØB	ØD	L	H	Hh	Hg	E	F	ØC	S	O	G1	G2	G3	Weight (kg)
PN 40																	
15	34		21.3	13	230	125				61	25	115					1.0
20	42.4		26.9	15	230	125				58	25	115					1.0
25	48.3	2.6	33.7	20	230	130				56	25	115					1.2
32	60.3		42.4	25	260	135				56	25	115					1.5
40	76.1		48.3	32	260	170				54	35	157					2.3
50	76.1	2.9	60.3	40	300	175				54	35	157					2.8
PN 25																	
65	102	2.9	76.1	50	260	205	265	130	87	73	35	205	200	140	40	100	6
80	121	3.2	88.9	65	270	225	290	130	84	88	39	260	250	205	54	131	11
100	159	3.6	114.3	80	290	270	320	140	95	108	39	405	250	205	54	131	16
125	180	3.6	139.7	100	315	270	340	150	115	109	44	505	250	205	54	132	22
150	219	4	168.3	125	340	310	355	150	140	109	49	645	250	205	54	132	30.3
200	273	4.5	219.1	150	390	315	400	160	140	127	60	650	250	205	54	132	45
250	356	6.3	273.0	200	530		613	224	340	181	88		450	169	78	192	110
300	457	8	323.9	250	660		661	237	400	199	100		450	242	107	255	221
350	457	8	355.6	250	760		661	237	400	183	100		450	242	107	255	229
400	521	8.8	406.4	300	820	-	714	281	480	217	140	-	450	285	143	323	304
450	711	10	457	400	1225		829	317	690	297	168		500	324	147	337	724
500	711	11	508	400	1220		829	317	690	272	168		500	324	147	337	739
600	711	12.5	610	400	1500		829	317	695	221	168		500	324	147	337	832

Weights are based on PN 40/25 versions. DN 250 - DN 600: Dimensions and weights are PN 25 and including worm gear.

JIP-II internal thread

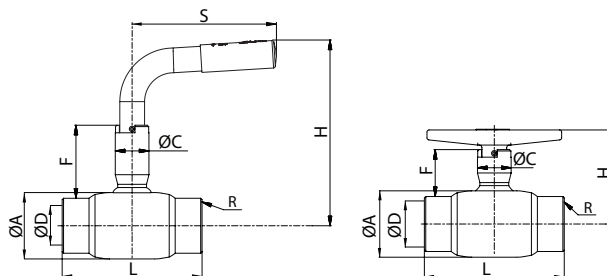

DN (mm)	ØA	R	ØD	L	H low	F low	H high	F high	ØC	S	Weight (kg)
15	42.4	1/2"	15	90	65	35	125	55	25	115	0.6
20	42.4	3/4"	15	90	65	35	125	55	25	115	0.8
25	48.3	1"	20	100	70	35	130	55	25	115	0.9
32	60.3	1 1/4"	25	105			135	55	25	115	1.2
40	76.1	1 1/2"	32	130			170	80	35	157	2.2
50	88.9	2"	40	150			175	80	35	157	3.3

Dimensions

JIP-FF flange/flange

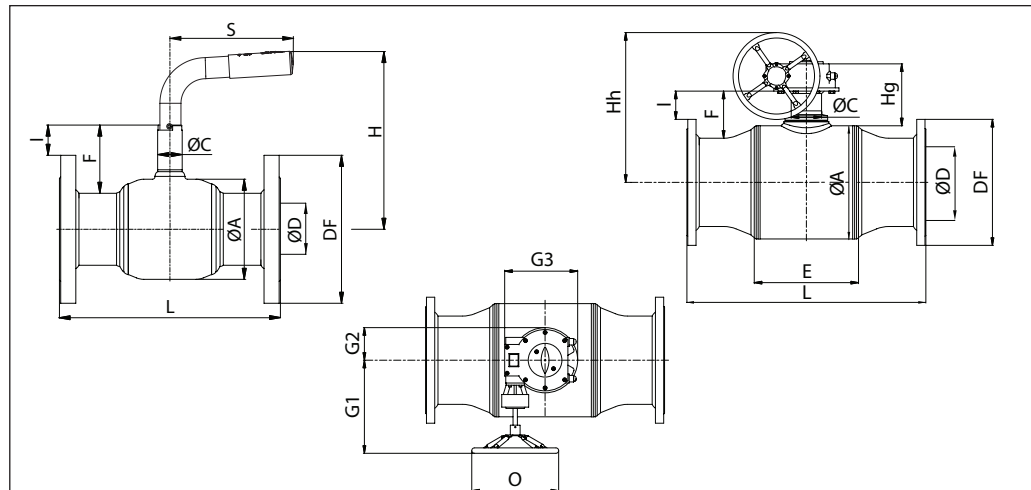

DN (mm)	ØA	ØD*	L	DF	I	L	DF	I	H	Hh	Hg	E	F	ØC	S	O	G1	G2	G3	Weight (kg)		
			PN 16			PN 40																
15	34	13				130	95	23	125													
20	42.4	15				150	105	19	125													
25	48.3	20				160	115	15	130													
32	60.3	25				180	140	10	135													
40	76.1	32				200	150	35	170													
50	76.1	40				230	165	35	175													
			PN 16			PN 25																
65	102	50	270	185	18	290	185	18	205	265	130	87	73	35	205	200	140	40	100	12		
80	121	65	280	200	33	310	200	33	225	290	130	84	88	39	260	250	205	54	131	18		
100	159	80	300	220	56	350	235	48	270	320	140	95	108	39	405	250	205	54	131	26		
125	180	100	325	250	54	400	270	44	270	340	150	115	109	44	505	250	205	54	132	32		
150	219	125	350	285	51	480	300	43	310	355	150	140	109	49	645	250	205	54	132	45		
200	273	150	400	340	66	600	360	56	315	400	160	140	127	60	650	250	205	54	132	74		
250	356	200	650	405	115	730	425	105			613	228	340	181	88			450	169	78	192	165
300	457	250	750	460	131	850	485	119			661	254	400	199	100			450	242	107	255	262
350	457	250	850	520	101	980	555	84			661	254	400	183	100			450	242	107	255	289
400	521	300	1100	580	130	1100	620	110			714	285	480	220	140			450	285	143	323	400
450	711	400	1255	640	206	1255	670	191			829	322	690	297	168			500	324	147	337	819
500	711	400	1250	715	169	1250	730	161			829	322	690	272	168			500	324	147	337	866

Weights are based on PN 40/25 versions. DN 250 - DN 600; Dimensions and weights are PN 25 and including worm gear.
 ØD* - internal nominal diameter

JIP-IW internal head/welding

DN (mm)	ØA	ØB	R	ØD*	L	H low T	F low	H high L	F high	ØC	S	Weight (kg)
15	42.4	21.3	½"	15	160	65	40	125	60	25	115	0.9
20	42.4	26.9	¾"	15	160	65	37	125	60	25	115	0.9
25	48.3	33.7	1"	20	165	70	37	130	55	25	115	1.0
32	60.3	42.4	1 ¼"	25	185			135	58	25	115	1.4
40	76.1	48.3	1 ½"	32	195			170	86	35	157	2.3
50	88.9	60.3	2"	40	225			175	86	35	157	3.3

ØD* - internal nominal diameter

Dimensions

JIP-FW flange/welding

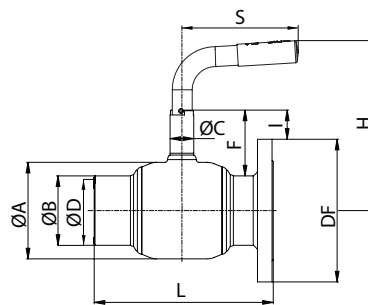

DN (mm)	ØA	ØB	ØD*	PN 16			PN 40			H	F	C	S	Weight (kg)
				L	DF	I	L	DF	I					
15	34	21.3	13				180	95	23	125	58	25	115	1.7
20	42.4	26.9	15				190	105	19	125	58	25	115	2.0
25	48.3	33.7	20				195	115	15	130	57	25	115	2.4
32	60.3	42.4	25				220	140	10	135	59	25	115	3.4
40	76.1	48.3	32				230	150	35	170	86	35	157	4.3
50	88.9	60.3	40				265	165	35	175	86	35	157	5.9
				PN 16			PN 25							
65	102	76.1	50	265	185	18	265	185	18	205	73	35	205	7
80	121	88.9	65	275	200	33	275	200	33	225	88	39	260	9
100	159	114.3	80	295	220	56	295	235	48	270	108	39	405	15
125	180	139.7	100	320	250	54	320	270	44	270	109	44	505	23
150	219	168.3	125	345	285	51	345	300	43	310	109	49	645	35
200	273	219.1	150	395	340	66	395	360	56	315	127	60	650	65

Weights are based on PN 40/25 versions. DN 250 - DN 600: Dimensions and weights are PN 25 and including worm gear. ØD* - internal nominal diameter

Valve top and gear flange

DN (mm)	Gear flange	l	Ød	mm			r
				n	p	q	
65	F07	31	16	27	5	13	4
80		45	20	41	6	165	
100		43	39	6	165		
125	F10/F12	50	24	46	8	26	6
150		27					
200		30					
250	F16	60	50	48	14	44.5	5
300		65	60	51	18	53.2	
350		65	60	51	18	53.2	
400	F25	75	75	60	20	60	6
450		75	75	60	20	60	
500		115	100	91	28	80	
600		115	100	91	28	80	

Gear flange	No. of bolt holes	Diameter of bolt holes	mm		
			ØD	ØK	ØR
F7	4	9	88	70	55
F10		11	125	102	70
F12		13	150	125	85
F16	8	21	210	165	130
F25		17	300	254	200
F30		21	350	298	230

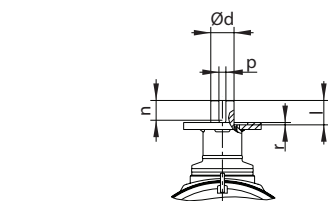

DN 65 - DN 350 Single Key

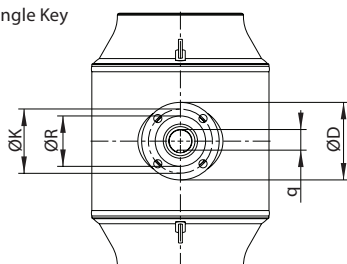

DN 400 - DN 600 Two Parallel Keys

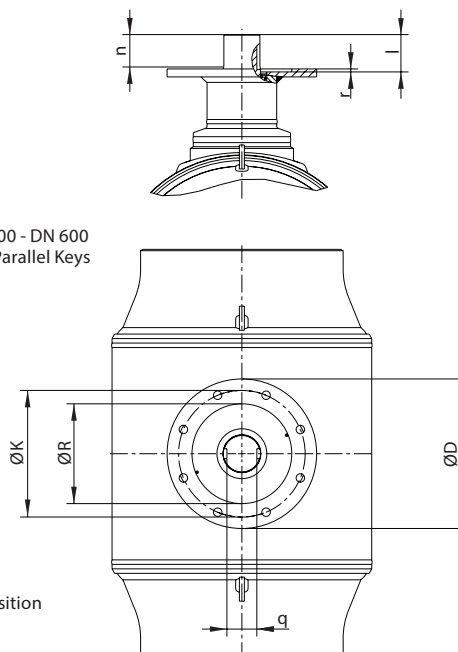

Dimensions

House insertions
 Single valve
 JIP-CC copper
 JIP-IC internal thread / copper
 Max temp. 130°

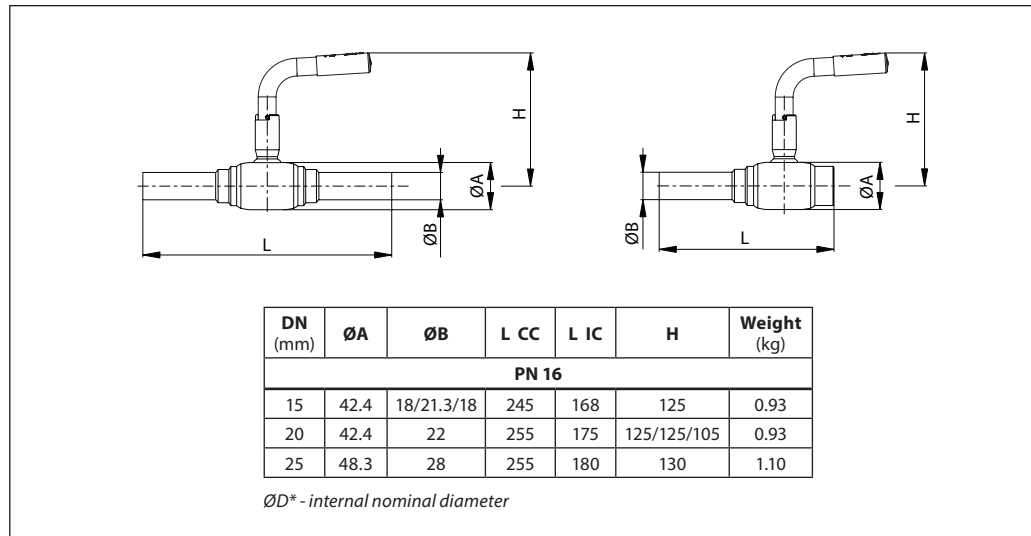

House insertions
 Twin valve - single pipe
 JIP-IC internal thread/copper
 Max temp. 130°

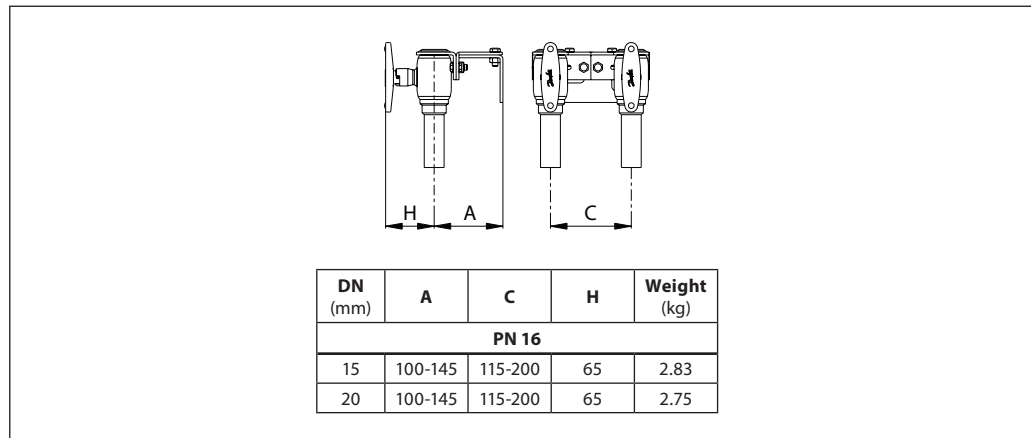

House insertions
 Twin valves - single pipe
 JIP-WW welding
 JIP-II internal thread
 JIP IW internal thread/welding

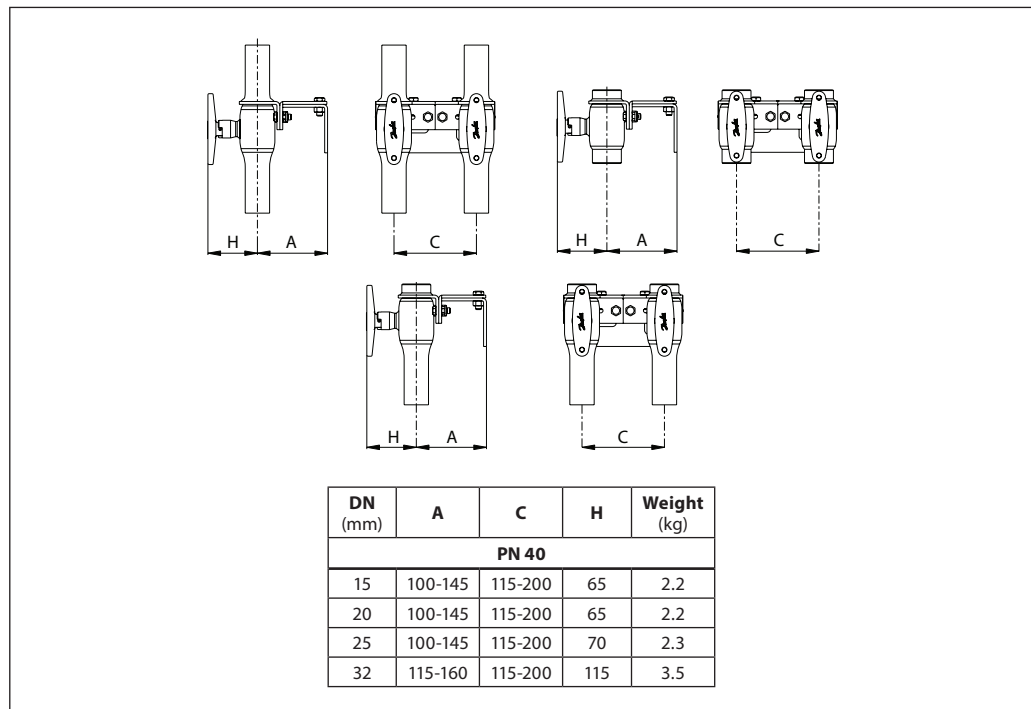

Dimensions

House insertions
 Twin valves - double pipe
 JIP-II/JIP-IW internal thread

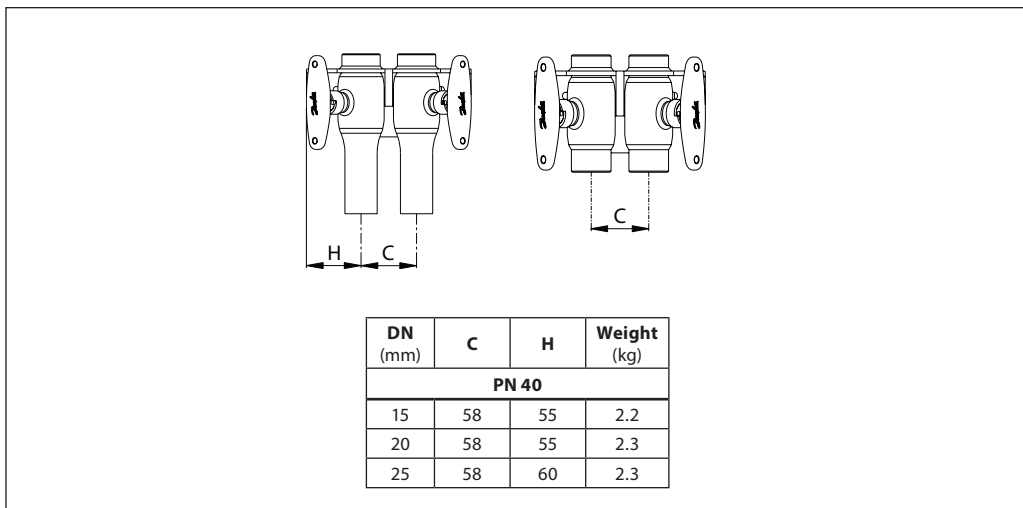

JIP-WE cc welding / external thread with closing cap

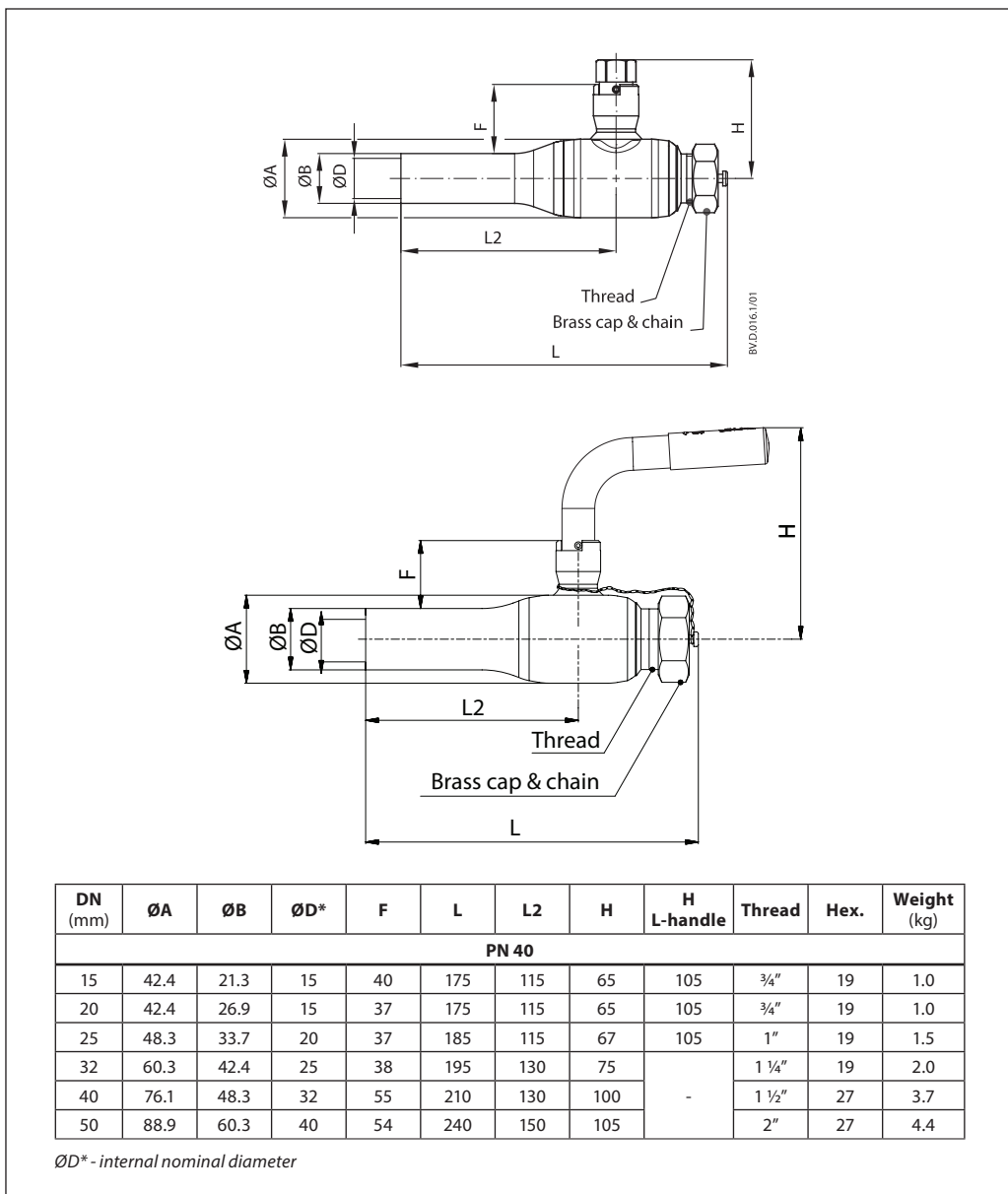

AUMA NORM electrical actuators for Danfoss ball valves

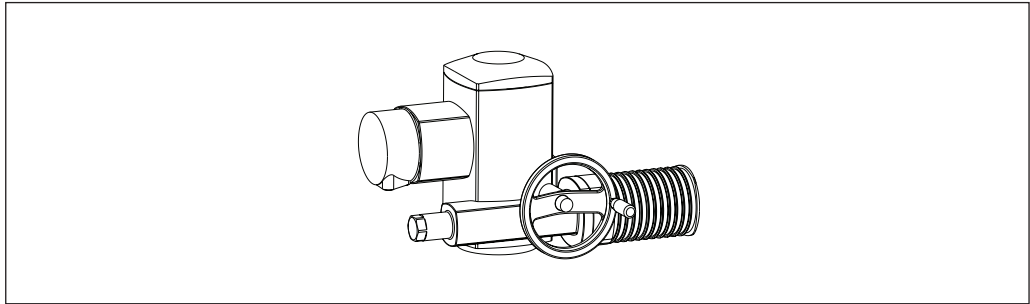

Danfoss ball valves	Auma Actuators	
DN (mm)	Type	Operating time for 90° turn (s)
65-80	SQ 05.2	16
100	SQ 07.2	32
125-150-200	SQ 10.2	32
250	SA 07.6+GS 100.3+VZ 4.3	142
300-350	SA 07.6+GS 125.3+VZ 4.3	142
400	SA 10.2+GS 125.3+VZ 4.3	142
450-500-600	SA 10.2+GS 160.3+GZ 160.3	207

The actuators can be equipped with various accessories. Control and regulating unit AUMA Matic in the basis design can be supplied. For other mains voltages than 3 × 400V/50Hz or additional questions please contact us.

When commissioning and under certain problematic system conditions, it can be necessary to choose slower actuators to avoid water hammering and oscillations.



For additional information related to the electric actuator ordering, please contact local Danfoss representative.

Features:

- 2 limit switches - opening/closing
- 2 torque switches - opening/closing
- Heater
- Blinker switch for operating phase
- Manual operation with hand wheel
- Thermo switch

Main Data:

- Nominal voltage: 3 × 400 VAC, 50Hz
- Grade of enclosure: IP 68
- Wiring diagram: TPA 00R1AA-000

Danfoss A/S

Climate Solutions • danfoss.com • +45 7488 2222

Any information, including, but not limited to information on selection of product, its application or use, product design, weight, dimensions, capacity or any other technical data in product manuals, catalogues descriptions, advertisements, etc. and whether made available in writing, orally, electronically, online or via download, shall be considered informative, and is only binding if and to the extent, explicit reference is made in a quotation or order confirmation. Danfoss cannot accept any responsibility for possible errors in catalogues, brochures, videos and other material. Danfoss reserves the right to alter its products without notice. This also applies to products ordered but not delivered provided that such alterations can be made without changes to form, fit or function of the product. All trademarks in this material are property of Danfoss A/S or Danfoss group companies. Danfoss and the Danfoss logo are trademarks of Danfoss A/S. All rights reserved.