

' B DAdet

Flow check DN 40 -250 drifting the flow on DN 40 to DN 250

Flow verification
in an installation

To verify that an installation functions according to the design specifications checking only the most critical valve in the installation is needed (see figure 1).
The AB-QM maintains a constant differential pressure over the valve and any excess pressure will automatically be throttled. If there is not enough differential pressure the valve cannot reach the set flow.
The valve that is furthest away from the pump or the valve in the circuit with the highest resistance has the lowest available differential pressure, so

if this critical valve has enough pressure it means the other valves will also function properly.

Important:

To get a useful measurement the installation should run on full load, so all actuators in the installation should be opened fully. This ensures that you are measuring under the most unfavorable circumstances. The AB-QM's will have more differential pressure available when the installation is working on partial load.

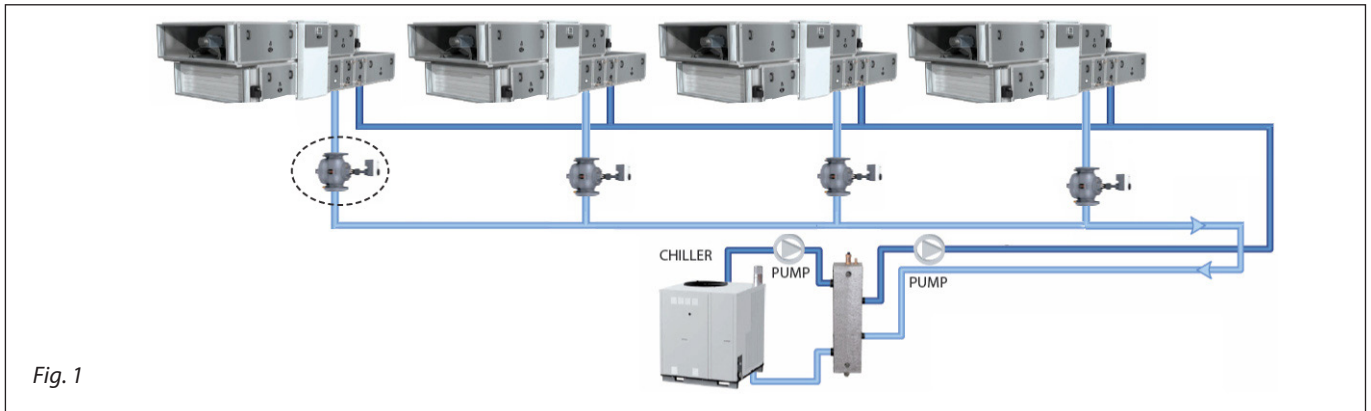

Fig. 1

Method of verification

Measure the differential pressure across the whole valve.
The measuring nipples are placed in such a way that differential pressure p_1-p_3 (Δp) over the valve is measured (see figure 2).
If the measured value is below 30 kPa then there is not enough differential pressure available for the AB-QM to function properly. If the measured value is above 30 kPa then the AB-QM has enough differential pressure available and the flow is according to the setting (see figure 3).

Setting the flow

DN 40-100: 1 turn=10 %
DN 125-250: 1 turn=5.0 %

Note: for more information about setting procedure please refer to instructions

Method of measurement

Measure the differential pressure across the control valve.
The measuring nipples are placed in such a way that p_1-p_2 is measured (see figure 2).
Therefore the measured differential pressure can be used to calculate the flow directly. It's necessary to use the table that was derived from statistical measurements
Since the measurements across the measuring points are influenced by the dynamic pressure, turbulences, flow patterns, internal tolerances, setting accuracy and accuracy of the measuring equipment we believe that the total accuracy of the measurement is lower than performance of the valve.
Therefore we recommend not to adjust the setting when the results are within 10 % of the expected flow.

Calculating the flow

$$\Delta p_{Qv} = p_1 - p_2$$

$$Q = kv_{Qv} \times \sqrt{\Delta p_{Qv}}$$

For kv_{Qv} values see tables in figure 4 and 7

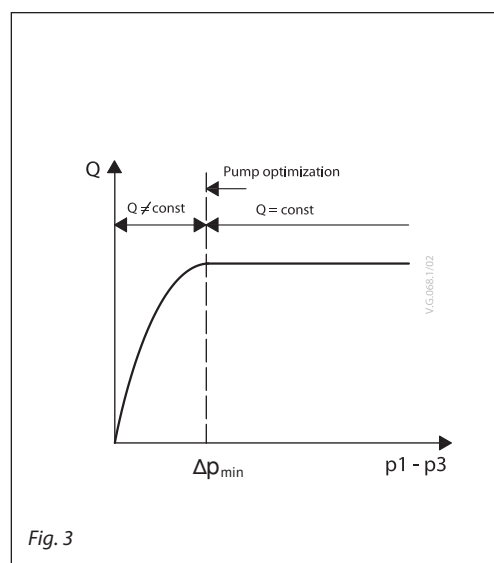
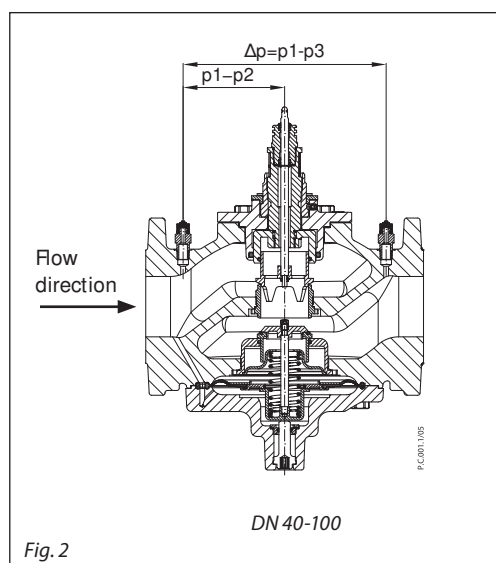

Presetting	DN 40	DN 50 / DN 50HF	DN 65 / DN 65HF	DN 80 / DN 80HF	DN 100 / DN 100HF
s %	kv _{0.5} (m ³ /h)				
20.0 %	3.40	4.60	4.20	15.50	19.50
22.5 %	4.08	5.55	5.48	17.19	21.94
25.0 %	4.80	6.50	6.75	18.88	24.38
27.5 %	5.43	7.45	8.03	20.56	26.81
30.0 %	6.10	8.40	9.30	22.25	29.25
32.5 %	6.78	9.35	10.58	23.94	31.69
35.0 %	7.50	10.30	11.85	25.63	34.13
37.5 %	8.13	11.25	13.13	27.31	36.56
40.0 %	8.80	12.20	14.40	29.00	39.00
42.5 %	9.48	13.15	15.68	30.69	41.44
45.0 %	10.20	14.10	16.95	32.38	43.88
47.5 %	10.83	15.05	18.23	34.06	46.31
50.0 %	11.50	16.00	19.50	35.75	48.75
52.5 %	12.18	16.95	20.78	37.44	51.19
55.0 %	12.90	17.90	22.05	39.13	53.63
57.5 %	13.53	18.85	23.33	40.81	56.06
60.0 %	14.20	19.80	24.60	42.50	58.50
62.5 %	14.88	20.75	25.88	44.19	60.94
65.0 %	15.55	21.70	27.15	45.88	63.38
67.5 %	16.26	22.65	28.43	47.56	65.81
70.0 %	16.90	23.60	29.70	49.25	68.25
72.5 %	17.58	24.55	30.98	50.94	71.81
75.0 %	18.25	25.50	32.25	52.63	75.38
77.5 %	18.93	26.45	33.53	54.31	78.94
80.0 %	19.60	27.40	34.80	56.00	82.50
82.5 %	20.28	28.35	36.08	57.69	86.06
85.0 %	20.95	29.30	37.35	59.38	89.63
87.5 %	21.63	30.25	38.63	61.06	93.19
90.0 %	22.30	31.20	39.90	62.75	96.75
92.5 %	22.98	32.15	41.18	64.44	100.31
95.0 %	23.65	33.10	42.45	66.13	103.88
97.5 %	24.33	34.05	43.73	67.81	107.44
100.0 %	25.00	35.00	45.00	69.50	111.00

Fig. 4 The flow is according to setting if the calculated flow is in the range of ±10 % of the set flow.

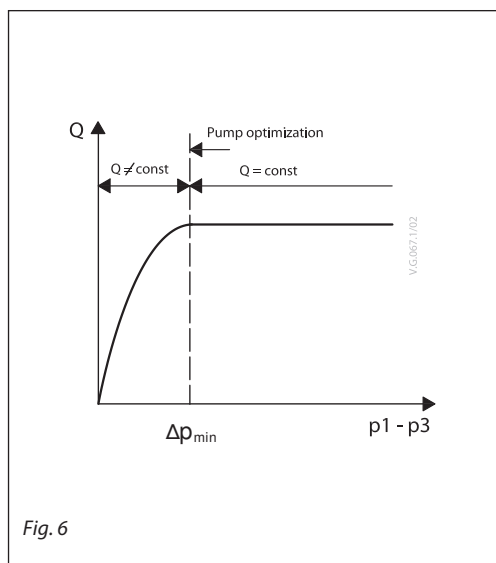
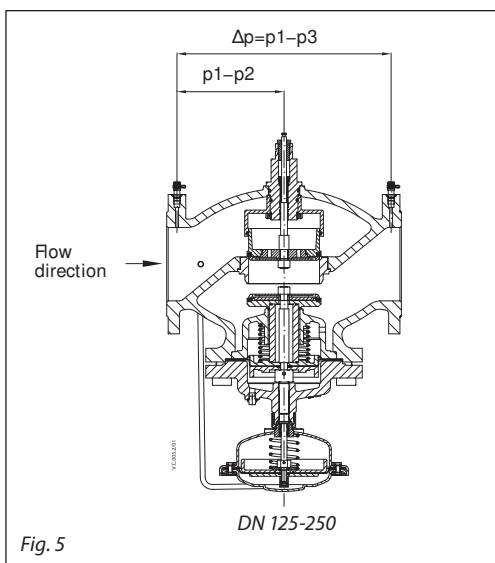

Presetting	DN 125 / DN 125HF	DN 150 / DN 150HF	DN 200 / DN 200HF	DN 250 / DN 250HF
s%	kv_{α} (m ³ /h)			
20.0 %	40	53	57	86
22.5 %	45	60	66	99
25.0 %	49	67	75	112
27.5 %	53	74	85	125
30.0 %	57	81	94	138
32.5 %	61	88	104	150
35.0 %	65	95	113	163
37.5 %	69	101	122	176
40.0 %	73	108	132	189
42.5 %	77	115	141	202
45.0 %	82	122	151	215
47.5 %	86	129	160	227
50.0 %	90	136	170	240
52.5 %	94	143	179	253
55.0 %	98	150	188	266
57.5 %	102	157	198	279
60.0 %	106	163	207	292
62.5 %	110	170	217	304
65.0 %	114	177	226	317
67.5 %	119	184	235	330
70.0 %	123	191	245	343
72.5 %	127	198	254	356
75.0 %	131	205	264	369
77.5 %	135	212	273	381
80.0 %	139	219	283	394
82.5 %	143	225	292	407
85.0 %	147	232	301	420
87.5 %	152	239	311	433
90.0 %	156	246	320	446
92.5 %	160	253	330	458
95.0 %	164	260	339	471
97.5 %	168	267	348	484
100.0 %	172	274	358	497
102.5%	176	281	367	510
105.0%	180	287	377	523
107.5%	184	294	386	535
110.0%	189	301	396	548

Fig. 7 The flow is according to setting if the calculated flow is in the range of ±10 % of the set flow.



Danfoss can accept no responsibility for possible errors in catalogues, brochures and other printed material. Danfoss reserves the right to alter its products without notice. This also applies to products already on order provided that such alterations can be made without subsequential changes being necessary in specifications already agreed. All trademarks in this material are property of the respective companies. Danfoss and the Danfoss logotype are trademarks of Danfoss A/S. All rights reserved.