

Installation guide

# Hot gas bypass regulator type CPCE

## Liquid gas mixer type LG (accessory)

034R9507

034R9507

**CPCE Refrigerants:**

R22, R1270, R134a, R290, R404A, R407A, R407C, R407F, R448A, R449A, R450A, R452A, R507A, R513A, R600, R600a

For complete list of approved refrigerants, visit [www.products.danfoss.com](http://www.products.danfoss.com) and search for individual code numbers, where refrigerants are listed as part of technical data.

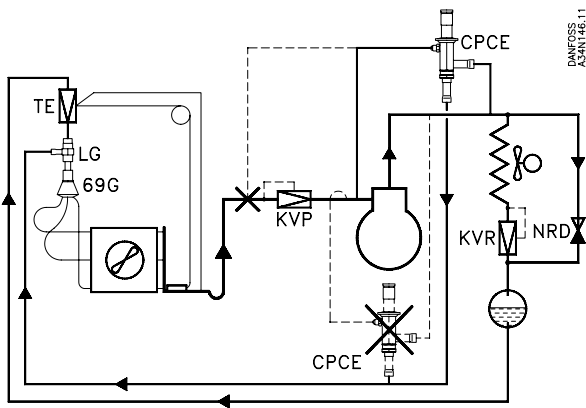
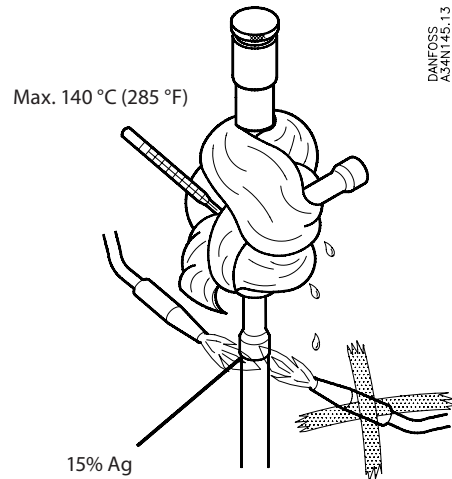
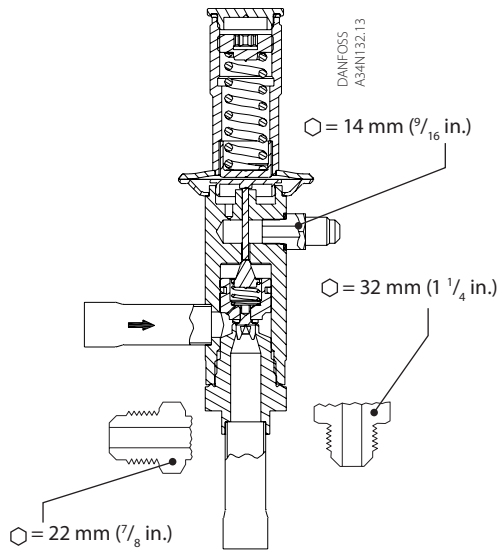
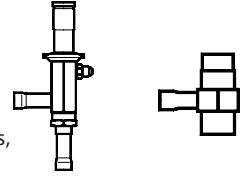

$t_{max.} = 140\text{ °C (285 °F)}$   
 $t_{min.} = -50\text{ °C (-60 °F)}$

PS/MWP = 28 bar  $p_e$  (405 psig)  
 $P_{max. test} = 31\text{ bar } p_e$  (450 psig)

**NB!** Tightening torque must be respected especially when used with flammable refrigerants

**4Nm** (finger tight + 1/4 turn)

